

CONTROL SECTION 1

NEMA full voltage power devices



Table of contents

Magnetic contactors	1-4
NEMA starters with NEMA-style components	1-15
NEMA starters with IEC-style components	1-103
Overload relays	1-113
Manual motor starters	1-122
Pumping panels	1-129

Magnetic contactors

Table of contents

Open/enclosed magnetic NEMA-style contactors

Product overview	1-5
CR305 non-reversing, single-phase, 1- and 2-pole	1-6
CR305 non-reversing, 3-phase, 3-pole	1-7
CR305 non-reversing, 3-phase, 4-pole	1-8

Field-installed contactor modification kits

Auxiliary contacts	1-9
Pilot device and fifth pole	1-11
Surge suppression and control circuit fuses	1-12
Control amplifier	1-13
Space heaters and mechanical interlocks	1-14

Open/enclosed magnetic NEMA-style contactors

Product overview

NEMA sizes 00–6
600 V maximum 50/60 Hz
600 Amperes maximum
400 hp maximum



CR305A002



CR306D10200AAAA

ABB's magnetic contactor is designed for use on today's modern equipment. Especially suitable for handling the switching of resistance heating and capacitor circuit loads, their compact size also fits the needs of the panel building industry. In addition, they may be used for controlling AC motors where overload protection is provided separately.

Features

- Easy disassembly for maintenance and inspection of contacts.
- Auxiliary contacts with vertical contact surfaces enclosed to prevent accumulation of dust and dirt.
- Attractive, modern, squared-off enclosure.
- Magnet faces specially treated to resist rust.
- Provision for ring terminals may be specified as a special feature if required.
- Each CR305 contactor is furnished with a normally open auxiliary contact for use as a holding interlock in three-wire control circuits. This auxiliary contact has the same rating as a main pole (contact) for sizes 00, 0 and 1. If this contact is not required on these sizes, specify contactor with one less pole.
- Motor full-load current should not exceed continuous ampere rating of contactor.

Please reference the [NEMA full voltage power devices catalog](#) for additional technical data, selection and installation guides, and dimensional drawings.

Open/enclosed magnetic NEMA-style contactors

CR305 non-reversing contactors, single-phase, 1- and 2-pole

1-pole magnetic contactors NEMA sizes 00–1

NEMA size	Continuous ampere rating ¹		Voltage @ 60 Hz	hp	Open type Ordering code	NEMA type 1 Ordering code	NEMA type 3R Ordering code	NEMA type 12 Ordering code	NEMA type 4/4X Ordering code
	Enclosed	Open							
00	9 A	10 A	115–120	½	Use NEMA size 0	Use NEMA size 0	–	–	–
00	9 A	10 A	230–240	1	Use NEMA size 0	Use NEMA size 0	–	–	–
0	18 A	20 A	115–120	1	CR305J002ADA	CR305J102ADA	–	–	–
0	18 A	20 A	230–240	2	CR305J003ADA	CR305J103ADA	–	–	–
1	27 A	30 A	115–120	2	CR305K002ADA	CR305K102ADA	–	–	CR305K402ADA
1	27 A	30 A	230–240	3	CR305K003ADA	CR305K103ADA	–	–	CR305K403ADA

2-pole magnetic contactors NEMA sizes 00–6

NEMA size	Continuous ampere rating ¹		Voltage @ 60 Hz	hp	Open type Ordering code	NEMA type 1 Ordering code	NEMA type 3R Ordering code	NEMA type 12 Ordering code	NEMA type 4/4X Ordering code
	Enclosed	Open							
00	9 A	10 A	115–120	½	CR305H002	CR305H102	Use NEMA size 0	Use NEMA size 0	Use NEMA size 0
00	9 A	10 A	230–240	1	CR305H003	CR305H103	Use NEMA size 0	Use NEMA size 0	Use NEMA size 0
0	18 A	20 A	115–120	1	CR305J002	CR305J102	CR305J602	CR305J202	CR305J402
0	18 A	20 A	230–240	2	CR305J003	CR305J103	CR305J603	CR305J203	CR305J403
1	27 A	30 A	115–120	2	CR305K002	CR305K102	CR305K602	CR305K202	CR305K402
1	27 A	30 A	230–240	3	CR305K003	CR305K103	CR305K603	CR305K203	CR305K403
2	45 A	50 A	115–120	3	CR305L002	CR305L102	CR305L602	CR305L202	CR305L402
2	45 A	50 A	230–240	7½	CR305L003	CR305L103	CR305L603	CR305L203	CR305L403
3	90 A	100 A	115–120	7½	CR305M002	CR305M102	CR305M602	CR305M202	CR305M402
3	90 A	100 A	230–240	15	CR305M003	CR305M103	CR305M603	CR305M203	CR305M403
3	90 A	100 A	460–480	25	CR305M004	CR305M104	CR305M604	CR305M204	CR305M404
3	90 A	100 A	575–600	25	CR305M005	CR305M105	CR305M605	CR305M205	CR305M405
4	135 A	150 A	115–120	–	CR305N002	CR305N102	CR305N602	CR305N202	CR305N402
4	135 A	150 A	200–208	–	CR305N023	CR305N123	CR305N623	CR305N223	CR305N423
4	135 A	150 A	230–240	–	CR305N003	CR305N103	CR305N603	CR305N203	CR305N403
4	135 A	150 A	460–480	–	CR305N004	CR305N104	CR305N604	CR305N204	CR305N404
4	135 A	150 A	575–600	–	CR305N005	CR305N105	CR305N605	CR305N205	CR305N405
5	270 A	300 A	115–120	–	CR305P002	CR305P102	CR305P602	CR305P202	CR305P402
5	270 A	300 A	200–208	–	CR305P023	CR305P123	CR305P623	CR305P223	CR305P423
5	270 A	300 A	230–240	–	CR305P003	CR305P103	CR305P603	CR305P203	CR305P403
5	270 A	300 A	460–480	–	CR305P004	CR305P104	CR305P604	CR305P204	CR305P404
5	270 A	300 A	575–600	–	CR305P005	CR305P105	CR305P605	CR305P205	CR305P405
6	540 A	600 A	115–120	–	CR305HR002	CR305HR102AA2A	CR305HR602AA2A	CR305HR202AA2A	CR305HR402AA2A
6	540 A	600 A	200–208	–	CR305HR023	CR305HR123AA2A	CR305HR623AA2A	CR305HR223AA2A	CR305HR423AA2A
6	540 A	600 A	230–240	–	CR305HR003	CR305HR103AA2A	CR305HR603AA2A	CR305HR203AA2A	CR305HR403AA2A
6	540 A	600 A	460–480	–	CR305HR004	CR305HR104AA2A	CR305HR604AA2A	CR305HR204AA2A	CR305HR404AA2A
6	540 A	600 A	575–600	–	CR305HR005	CR305HR105AA2A	CR305HR605AA2A	CR305HR205AA2A	CR305HR405AA2A

Please reference the [NEMA full voltage power devices catalog](#) for additional technical data, selection and installation guides, and dimensional drawings.

Open/enclosed magnetic NEMA-style contactors

CR305 non-reversing contactors, 3-phase, 3-pole

3-phase, 3-pole magnetic contactors NEMA sizes 00–6

NEMA size	Continuous ampere rating ¹		Voltage @ 60 Hz	hp	Open type Ordering code	NEMA type 1 Ordering code	NEMA type 3R Ordering code	NEMA type 12 Ordering code	NEMA type 4/4X Ordering code
	Enclosed	Open							
00	9 A	10 A	115–120	–	CR305A002	CR305A102	Use NEMA size 0	Use NEMA size 0	Use NEMA size 0
00	9 A	10 A	200–208	1½	CR305A023	CR305A123	Use NEMA size 0	Use NEMA size 0	Use NEMA size 0
00	9 A	10 A	230–240	1½	CR305A003	CR305A103	Use NEMA size 0	Use NEMA size 0	Use NEMA size 0
00	9 A	10 A	460–480	2	CR305A004	CR305A104	Use NEMA size 0	Use NEMA size 0	Use NEMA size 0
00	9 A	10 A	575–600	2	CR305A005	CR305A105	Use NEMA size 0	Use NEMA size 0	Use NEMA size 0
0	18 A	20 A	115–120	–	CR305B002	CR305B102	CR305B602	CR305B202	CR305B402
0	18 A	20 A	200–208	3	CR305B023	CR305B123	CR305B623	CR305B223	CR305B423
0	18 A	20 A	230–240	3	CR305B003	CR305B103	CR305B603	CR305B203	CR305B403
0	18 A	20 A	460–480	5	CR305B004	CR305B104	CR305B604	CR305B204	CR305B404
0	18 A	20 A	575–600	5	CR305B005	CR305B105	CR305B605	CR305B205	CR305B405
1	27 A	30 A	115–120	–	CR305C002	CR305C102	CR305C602	CR305C202	CR305C402
1	27 A	30 A	200–208	7½	CR305C023	CR305C123	CR305C623	CR305C223	CR305C423
1	27 A	30 A	230–240	7½	CR305C003	CR305C103	CR305C603	CR305C203	CR305C403
1	27 A	30 A	460–480	10	CR305C004	CR305C104	CR305C604	CR305C204	CR305C404
1	27 A	30 A	575–600	10	CR305C005	CR305C105	CR305C605	CR305C205	CR305C405
2	45 A	50 A	115–120	–	CR305D002	CR305D102	CR305D602	CR305D202	CR305D402
2	45 A	50 A	200–208	10	CR305D023	CR305D123	CR305D623	CR305D223	CR305D423
2	45 A	50 A	230–240	15	CR305D003	CR305D103	CR305D603	CR305D203	CR305D403
2	45 A	50 A	460–480	25	CR305D004	CR305D104	CR305D604	CR305D204	CR305D404
2	45 A	50 A	575–600	25	CR305D005	CR305D105	CR305D605	CR305D205	CR305D405
3	90 A	100 A	115–120	–	CR305E002	CR305E102	CR305E602	CR305E202	CR305E402
3	90 A	100 A	200–208	25	CR305E023	CR305E123	CR305E623	CR305E223	CR305E423
3	90 A	100 A	230–240	30	CR305E003	CR305E103	CR305E603	CR305E203	CR305E403
3	90 A	100 A	460–480	50	CR305E004	CR305E104	CR305E604	CR305E204	CR305E404
3	90 A	100 A	575–600	50	CR305E005	CR305E105	CR305E605	CR305E205	CR305E405
4	135 A	150 A	115–120	–	CR305F002	CR305F102	CR305F602	CR305F202	CR305F402
4	135 A	150 A	200–208	40	CR305F023	CR305F123	CR305F623	CR305F223	CR305F423
4	135 A	150 A	230–240	50	CR305F003	CR305F103	CR305F603	CR305F203	CR305F403
4	135 A	150 A	460–480	100	CR305F004	CR305F104	CR305F604	CR305F204	CR305F404
4	135 A	150 A	575–600	100	CR305F005	CR305F105	CR305F605	CR305F205	CR305F405
5	270 A	300 A	115–120	–	CR305G002	CR305G102	CR305G602	CR305G202	CR305G402
5	270 A	300 A	200–208	75	CR305G023	CR305G123	CR305G623	CR305G223	CR305G423
5	270 A	300 A	230–240	100	CR305G003	CR305G103	CR305G603	CR305G203	CR305G403
5	270 A	300 A	460–480	200	CR305G004	CR305G104	CR305G604	CR305G204	CR305G404
5	270 A	300 A	575–600	200	CR305G005	CR305G105	CR305G605	CR305G205	CR305G405
6	540 A	600 A	115–120	–	CR305HH002	CR305HH102AA2A	CR305HH602AA2A	CR305HH202AA2A	CR305HH402AA2A
6	540 A	600 A	200–208	150	CR305HH023	CR305HH123AA2A	CR305HH623AA2A	CR305HH223AA2A	CR305HH423AA2A
6	540 A	600 A	230–240	200	CR305HH003	CR305HH103AA2A	CR305HH603AA2A	CR305HH203AA2A	CR305HH403AA2A
6	540 A	600 A	460–480	400	CR305HH004	CR305HH104AA2A	CR305HH604AA2A	CR305HH204AA2A	CR305HH404AA2A
6	540 A	600 A	575–600	400	CR305HH005	CR305HH105AA2A	CR305HH605AA2A	CR305HH205AA2A	CR305HH405AA2A

Please reference the [NEMA full voltage power devices catalog](#) for additional technical data, selection and installation guides, and dimensional drawings.

Open/enclosed magnetic NEMA-style contactors

CR305 non-reversing contactors, 3-phase, 4-pole

3-phase, 4-pole magnetic contactors NEMA sizes 00-5

NEMA size	Continuous ampere rating ¹		Voltage @ 60 Hz	hp	Open type Ordering code	NEMA type 1 Ordering code	NEMA type 3R Ordering code	NEMA type 12 Ordering code	NEMA type 4/4X Ordering code
	Enclosed	Open							
0	18 A	20 A	115-120	-	CR305R002AEA	CR305R102AEA	CR305R602AEA	CR305R202AEA	CR305R402AEA
0	18 A	20 A	200-208	3	CR305R023AEA	CR305R123AEA	CR305R623AEA	CR305R223AEA	CR305R423AEA
0	18 A	20 A	230-240	3	CR305R003AEA	CR305R103AEA	CR305R603AEA	CR305R203AEA	CR305R403AEA
0	18 A	20 A	460-480	5	CR305R004AEA	CR305R104AEA	CR305R604AEA	CR305R204AEA	CR305R404AEA
0	18 A	20 A	575-600	5	CR305R005AEA	CR305R105AEA	CR305R605AEA	CR305R205AEA	CR305R405AEA
1	27 A	30 A	115-120	-	CR305S002AEA	CR305S102AEA	CR305S602AEA	CR305S202AEA	CR305S402AEA
1	27 A	30 A	200-208	7½	CR305S023AEA	CR305S123AEA	CR305S623AEA	CR305S223AEA	CR305S423AEA
1	27 A	30 A	230-240	½	CR305S003AEA	CR305S103AEA	CR305S603AEA	CR305S203AEA	CR305S403AEA
1	27 A	30 A	460-480	10	CR305S004AEA	CR305S104AEA	CR305S604AEA	CR305S204AEA	CR305S404AEA
1	27 A	30 A	575-600	10	CR305S005AEA	CR305S105AEA	CR305S605AEA	CR305S205AEA	CR305S405AEA
2	45 A	50 A	115-120	-	CR305T002	CR305T102	CR305T602	CR305T202	CR305T402
2	45 A	50 A	200-208	10	CR305T023	CR305T123	CR305T623	CR305T223	CR305T423
2	45 A	50 A	230-240	15	CR305T003	CR305T103	CR305T603	CR305T203	CR305T403
2	45 A	50 A	460-480	25	CR305T004	CR305T104	CR305T604	CR305T204	CR305T404
2	45 A	50 A	575-600	25	CR305T005	CR305T105	CR305T605	CR305T205	CR305T405
3	90 A	100 A	115-120	-	CR305U002	CR305U102	CR305U602	CR305U202	CR305U402
3	90 A	100 A	200-208	25	CR305U023	CR305U123	CR305U623	CR305U223	CR305U423
3	90 A	100 A	230-240	30	CR305U003	CR305U103	CR305U603	CR305U203	CR305U403
3	90 A	100 A	460-480	50	CR305U004	CR305U104	CR305U604	CR305U204	CR305U404
3	90 A	100 A	575-600	50	CR305U005	CR305U105	CR305U605	CR305U205	CR305U405
4	135 A	150 A	115-120	-	CR305W002	CR305W102	CR305W602	CR305W202	CR305W402
4	135 A	150 A	200-208	40	CR305W023	CR305W123	CR305W623	CR305W223	CR305W423
4	135 A	150 A	230-240	50	CR305W003	CR305W103	CR305W603	CR305W203	CR305W403
4	135 A	150 A	460-480	100	CR305W004	CR305W104	CR305W604	CR305W204	CR305W404
4	135 A	150 A	575-600	100	CR305W005	CR305W105	CR305W605	CR305W205	CR305W405
5	270 A	300 A	115-120	-	CR305Z002	CR305Z102	CR305Z602	CR305Z202	CR305Z402
5	270 A	300 A	200-208	75	CR305Z023	CR305Z123	CR305Z623	CR305Z223	CR305Z423
5	270 A	300 A	230-240	100	CR305Z003	CR305Z103	CR305Z603	CR305Z203	CR305Z403
5	270 A	300 A	460-480	200	CR305Z004	CR305Z104	CR305Z604	CR305Z204	CR305Z404
5	270 A	300 A	575-600	200	CR305Z005	CR305Z105	CR305Z605	CR305Z205	CR305Z405

¹Motor full-load current should not exceed continuous ampere rating of contactor.

Please reference the [NEMA full voltage power devices catalog](#) for additional technical data, selection and installation guides, and dimensional drawings.

Field-installed contactor modification kits

Auxiliary contacts

NEMA sizes 0-6



CR305X100A

Auxiliary contacts can add to the versatility of magnetic contactors by providing additional control circuits to do a variety of jobs without adding to the width of the contactor.

Kits make it easy to add contacts to control accessory equipment such as indicating lights. Auxiliary contacts can be added to all across-the-line magnetic contactors. Each auxiliary contact is rated 10 amperes AC, resistive load, NEMA "A600," and is suitable for either right or left side mounting. An insulating shield is also provided between each auxiliary contact unit and the contactor.

Auxiliary contacts are furnished in the basic block design or as an adder block. Each contact is marked NO or NC on the block and is not convertible. Logic reed contacts suitable for low energy level circuits are also available. These are designed for applications on low-voltage control circuits (24 volts and below), such as inputs to computers and programmable starters.

Please reference the [NEMA full voltage power devices catalog](#) for additional technical data, selection and installation guides, and dimensional drawings.

Field-installed contactor modification kits

Auxiliary contacts

For CR305 contactors

Auxiliary contact kits

NEMA size	Contact configuration	Block design	Ordering code
0, 1	1 NO	Basic	CR305X100A
0, 1	1 NC	Basic	CR305X100B
0, 1	1 NO-1 NC	Basic	CR305X100C
2	1 NO	Basic	CR305X200A
2	1 NC	Basic	CR305X200B
2	1 NO-1 NC	Basic	CR305X200C
3, 4	1 NO	Basic	CR305X300A
3, 4	1 NC	Basic	CR305X300B
3, 4	1 NO-1 NC	Basic	CR305X300C
5, 6	1 NO	Basic	CR305X500A
5, 6	1 NC	Basic	CR305X500B
5, 6	1 NO-1 NC	Basic	CR305X500C

Auxiliary contact kits — adder blocks

NEMA size	Contact configuration	Block design	Ordering code
0-6	1 NO	Adder	CR305X100D ¹
0-6	1 NC	Adder	CR305X100E ¹

Logic reed switch auxiliary contacts

NEMA size	Contact configuration	Ordering code
00, 0, 1	1 NO-0 NC	CR305X100RA
00, 0, 1	0 NO-1 NC	CR305X100RB
00, 0, 1	1 NO-1 NC	CR305X100RC
2	1 NO-0 NC	CR305X200RA
2	0 NO-1 NC	CR305X200RB
2	1 NO-1 NC	CR305X200RC
3, 4	1 NO-0 NC	CR305X300RA
3, 4	0 NO-1 NC	CR305X300RB
3, 4	1 NO-1 NC	CR305X300RC
5, 6	1 NO-0 NC	CR305X500RA
5, 6	0 NO-1 NC	CR305X500RB
5, 6	1 NO-1 NC	CR305X500RC

¹First adder block must be mounted to a basic block. A second adder block can be added to the first adder block on size 2 through size 9 starters.

Four extra auxiliary contacts (not blocks) is the maximum that can be added to either a NEMA size 0 or 1 starter while five is the maximum extra auxiliary contacts that can be added to NEMA size 2 through 6 devices.

Please reference the [NEMA full voltage power devices catalog](#) for additional technical data, selection and installation guides, and dimensional drawings.

Field-installed contactor modification kits

Pilot device and fifth pole

NEMA sizes 00-6



CR305X120N



CR305X130N



CR305X211B

Pilot device modification kits

Kit type	NEMA size	Ordering code
Momentary contact start-stop push button kit	00, 0, 1	CR305X120N
Momentary contact start-stop push button kit	2	CR305X220N
Momentary contact start-stop push button kit	3, 4	CR305X320B
Momentary contact start-stop push button kit	5	CR305X520B
Hand-off-auto selector switch kit	00, 0, 1	CR305X130N
Hand-off-auto selector switch kit	2	CR305X230N
Hand-off-auto selector switch kit	3, 4	CR305X330B
Hand-off-auto selector switch kit	5	CR305X530B
Off-on selector switch kit	00, 0, 1	CR305X130P
Off-on selector switch kit	2	CR305X230D
Off-on selector switch kit	3, 4	CR305X330D
Off-on selector switch kit	5	CR305X530D

Fifth-pole kits

NEMA size	Mounting position	Ordering code
0, 1	Right	CR305X111B
2 (add to 4-pole form)	Left	CR305X211B

Please reference the [NEMA full voltage power devices catalog](#) for additional technical data, selection and installation guides, and dimensional drawings.

Field-installed contactor modification kits

Surge suppression and control circuit fuses

NEMA sizes 00–6



CR305X146C

Surge suppression kit

NEMA size	Ordering code
0–6	CR305X146C

Control circuit fuse kits

NEMA size	No. of fuses	Fuse type	Ordering code
00–1	1	KTK	CR305X141A
00–1	2	KTK	CR305X141B
2	1	KTK	CR305X241A
2	2	KTK	CR305X241B
3, 4	1	KTK	CR305X341A
3, 4	2	KTK	CR305X341B
5, 6	1	KTK	CR305X541A
5, 6	2	KTK	CR305X541B
00–1	1	KTK-R	CR305X141C
00–1	2	KTK-R	CR305X141D
2	1	KTK-R	CR305X241C
2	2	KTK-R	CR305X241D
3, 4	1	KTK-R	CR305X341C
3, 4	2	KTK-R	CR305X341D
5, 6	1	KTK-R	CR305X541C
5, 6	2	KTK-R	CR305X541D

Please reference the [NEMA full voltage power devices catalog](#) for additional technical data, selection and installation guides, and dimensional drawings.

Field-installed contactor modification kits

Control amplifier

NEMA sizes 00–6

Control amplifier

Operation type	NEMA size	Ordering code
Non-reversing	00, 0, and 1	CR305X112A
Non-reversing	2	CR305X212A
Non-reversing	3 and 4	CR305X312A
Non-reversing	00, 0, 1, 2, 3, and 4	CR305X112P ¹

¹A quantity of two panel-mount CR305X112P is required for use with reversing contactors and starters.

Please reference the [NEMA full voltage power devices catalog](#) for additional technical data, selection and installation guides, and dimensional drawings.

Field-installed contactor modification kits

Space heaters and mechanical interlocks

NEMA sizes 00–6



7GSP009115R0006

Space heater kits

NEMA size	Operating voltage	Ordering code
0–1	115	CR305X701D ¹
0–1	230	CR305X701A
0–1	460	CR305X701B
0–1	600	CR305X701C
2, 3, 4	115	CR305X702D
2, 3, 4	230	CR305X702A
2, 3, 4	460	CR305X702B
2, 3, 4	600	CR305X702C
5, 6	115	CR305X705D ¹
5, 6	230	CR305X705A
5, 6	460	CR305X705B
5, 6	600	CR305X705C

Mechanical interlock kits

NEMA size	Mounting position	Baseplate	Ordering code
0–1	Horizontal	No	CR309X100B
2	Horizontal	No	CR309X200D
3–4	Horizontal	No	CR309X300B
5	Horizontal	Yes	CR309X501K
0–1	Vertical	Yes	CR309X102B ²
2	Vertical	Yes	CR309X202B ²
3–4	Vertical	Yes	CR309X302B ²

¹If connected to control circuit transformer, 115-volt heater requires an extra-capacity transformer. Contact nearest ABB representative for additional information.

²For contactors top and bottom or contactor on top.

Please reference the [NEMA full voltage power devices catalog](#) for additional technical data, selection and installation guides, and dimensional drawings.

NEMA starters with NEMA-style components

Table of contents

300-line starters introduction	
Product overview	1-16
Open/enclosed non-combination magnetic starters	
CR306 non-reversing with thermal overload relay	1-17
CR306 non-reversing with solid-state overload relay	1-20
CR309 reversing with thermal overload relay	1-23
CR309 2-speed starters	1-25
Enclosed combination magnetic starters	
Product overview	1-28
CR307, CR407 non-reversing with thermal magnetic circuit breaker	1-29
CR308, CR408 non-reversing with disconnect switch	1-37
CR387, CR487 non-reversing with instantaneous trip circuit breaker	1-48
CR410 reversing with thermal magnetic circuit breaker	1-58
CR411 reversing with disconnect switch	1-62
CR490 reversing with instantaneous trip circuit breaker	1-67
CR412 2-speed/1-winding with thermal magnetic circuit breaker	1-71
CR413 2-speed/1-winding with disconnect switch	1-75
CR492 2-speed/1-winding with instantaneous trip circuit breaker	1-80
CR414 2-speed/2-winding with thermal magnetic circuit breaker	1-84
CR415 2-speed/2-winding with disconnect switch	1-88
CR494 2-speed/2-winding with instantaneous trip circuit breaker	1-93
Field-installed starter modification kits	
Auxiliary contacts	1-97
Surge suppression and control circuit fuses	1-99
Combination starter transformers	1-100
Control amplifier and space heater	1-101
Mechanical interlocks	1-102

300-line starters

Product overview

1600 horsepower maximum
NEMA sizes 00–6
600 volts maximum
50/60 Hz



CR306C002

Features

ABB's full voltage (600-volt maximum) magnetic motor starter has an encapsulated coil and a 3-leg overload relay to protect against overloads in all phases. It is on standard specifications of major manufacturers. The line offers features and benefits most asked for by users. Forms available include reversing and non-reversing, two-speed and combination, sizes 00–6.

- Toolless contactor disassembly (sizes 00–4) — allows quick access for inspection and maintenance. Just release two retainers and pull a clip to get at magnet, coil and contacts.
- Saddle clamp terminals (sizes 00–1) — accommodate ring, spade and stripped wire leads and carry permanent stamped-in identification. Staggered arrangement makes wiring easier and helps prevent shorting between phases.
- Current-carrying components — contact tips are weld-resistant silver cadmium oxide (fine silver on sizes 00 and 0 only). Contacts are installed in a wedge configuration for positive make with minimum bounce.
- Optional PF capacitor terminals — permit easy connection of power factor correction capacitors between contactor and overload relay for energy conservation.
- Class 20 overload protection.
- Visual trip indicator with manual reset — to avoid surprise restarts. Reset occurs on arm upstroke so a tripped condition can't be overridden by holding the arm down.
- Manual weld check — provides a convenient test against welding of overload relay contacts. Just depress the weld check operator to trip the relay, run a simple continuity test across the relay contacts, then depress the manual reset to return the starter to service.
- Optional isolated NO contact on the overload relay — provides means of direct interface with programmable controller or computer to monitor performance and diagnose faults.
- Dual bimetals — anticipate overloads, responding to rising current and temperature with faster tripping on severe overloads for better motor protection. Trip points are factory-calibrated for accuracy.
- $\pm 10\%$ trip adjustment — turning a dial in the overload relay face allows "tuning" the protection to the motor on the spot.
- Largest selection of modifications and accessory kits — includes auxiliary contacts, coils, fifth-pole addition, vertical and horizontal mechanical interlocks, surge suppressors, control circuit fusing, NEMA type enclosures, pushbuttons, selector switches, indicating lights, control transformers, space heaters and more.

Please reference the [NEMA full voltage power devices catalog](#) for additional technical data, selection and installation guides, and dimensional drawings.

Open/enclosed non-combination magnetic starters

CR306 non-reversing with thermal overload relay

**NEMA sizes 00–6 with
thermal overload relay
600 volts maximum
50/60 Hz**



CR306B002

ABB's magnetic motor starters listed here may be used for starting full-voltage, non-reversing, single-speed AC motors up to 400 horsepower, 600 volts maximum, providing protection to the motor against running or stalled overloads.

Their compact size and ease of wiring make them especially suitable for motor control centers, custom-type control panels and switchgear equipment.

Single-phase standard features

Includes a holding interlock. One heater (per starter) for sizes 00–2 and two heaters (per starter) for size 3 should be ordered as separate items. See heaters section.

Three-phase standard features

Includes a holding interlock, pressure terminals for the line and load connections, plus a 3-leg block type ambient compensated overload relay with manual reset. All enclosures include external reset. NO/NC contacts on the overload relay are provided. To order, add suffix LAA to ordering codes (size 00–5) listed in table. Three heaters should be ordered as separate items.

Please reference the [NEMA full voltage power devices catalog](#) for additional technical data, selection and installation guides, and dimensional drawings.

Open/enclosed non-combination magnetic starters

CR306 non-reversing with thermal overload relay

Single-phase magnetic starters

NEMA size	Continuous ampere rating ¹	Voltage	hp	Open type	NEMA type 1	NEMA type 3R	NEMA type 12	NEMA type 4/4X
				Ordering code	Ordering code	Ordering code	Ordering code	Ordering code
00	9	115–120	$\frac{1}{3}$	CR306H002	CR306H102	Use NEMA size 0	Use NEMA size 0	Use NEMA size 0
00	9	230–240	1	CR306H003	CR306H103	Use NEMA size 0	Use NEMA size 0	Use NEMA size 0
0	18	115–120	1	CR306J002	CR306J102	CR306J602	CR306J202	CR306J402
0	18	230–240	2	CR306J003	CR306J103	CR306J603	CR306J203	CR306J403
1	27	115–120	2	CR306K002	CR306K102	CR306K602	CR306K202	CR306K402
1	27	230–240	3	CR306K003	CR306K103	CR306K603	CR306K203	CR306K403
1P	36	115–120	3	CR306K002BMA	CR306K102BKA	CR306K602BKA	CR306K202BKA	CR306K402BKA
1P	36	230–240	5	CR306K003BMA	CR306K103BKA	CR306K603BKA	CR306K203BKA	CR306K403BKA
2	45	115–120	3	CR306L002	CR306L102	CR306L602	CR306L202	CR306L402
2	45	230–240	$7\frac{1}{2}$	CR306L003	CR306L103	CR306L603	CR306L203	CR306L403
3	90	115–120	$7\frac{1}{2}$	CR306M002	CR306M102	CR306M602	CR306M202	CR306M402
3	90	230–240	15	CR306M003	CR306M103	CR306M603	CR306M203	CR306M403
3	90	460–480	25	CR306M004	CR306M104	CR306M604	CR306M204	CR306M404
3	90	575–600	25	CR306M005	CR306M105	CR306M605	CR306M205	CR306M405

¹Motor full load current should not exceed continuous ampere rating of the starter.

Please reference the [NEMA full voltage power devices catalog](#) for additional technical data, selection and installation guides, and dimensional drawings.

Open/enclosed non-combination magnetic starters

CR306 non-reversing with thermal overload relay

Three-phase magnetic starters

NEMA size	Continuous ampere rating ¹	Voltage	hp	Open type	NEMA type 1	NEMA type 3R	NEMA type 12	NEMA type 4/4X
				Ordering code	Ordering code	Ordering code	Ordering code	Ordering code
00	9	Separate control—115–120 V		CR306A002	CR306A102	Use NEMA size 0	Use NEMA size 0	Use NEMA size 0
00	9	200–208	1½	CR306A023	CR306A123	Use NEMA size 0	Use NEMA size 0	Use NEMA size 0
00	9	230–240	1½	CR306A003	CR306A103	Use NEMA size 0	Use NEMA size 0	Use NEMA size 0
00	9	460–480	2	CR306A004	CR306A104	Use NEMA size 0	Use NEMA size 0	Use NEMA size 0
00	9	575–600	2	CR306A005	CR306A105	Use NEMA size 0	Use NEMA size 0	Use NEMA size 0
0	18	Separate control—115–120 V		CR306B002	CR306B102	CR306B602	CR306B202	CR306B402
0	18	200–208	3	CR306B023	CR306B123	CR306B623	CR306B223	CR306B423
0	18	230–240	3	CR306B003	CR306B103	CR306B603	CR306B203	CR306B403
0	18	460–480	5	CR306B004	CR306B104	CR306B604	CR306B204	CR306B404
0	18	575–600	5	CR306B005	CR306B105	CR306B605	CR306B205	CR306B405
1	27	Separate control—115–120 V		CR306C002	CR306C102	CR306C602	CR306C202	CR306C402
1	27	200–208	7½	CR306C023	CR306C123	CR306C623	CR306C223	CR306C423
1	27	230–240	7½	CR306C003	CR306C103 ²	CR306C603	CR306C203	CR306C403
1	27	460–480	10	CR306C004	CR306C104	CR306C604	CR306C204	CR306C404
1	27	575–600	10	CR306C005	CR306C105	CR306C605	CR306C205	CR306C405
2	45	Separate control—115–120 V		CR306D002	CR306D102	CR306D602	CR306D202	CR306D402
2	45	200–208	10	CR306D023	CR306D123	CR306D623	CR306D223	CR306D423
2	45	230–240	15	CR306D003	CR306D103	CR306D603	CR306D203	CR306D403
2	45	460–480	25	CR306D004	CR306D104	CR306D604	CR306D204	CR306D404
2	45	575–600	25	CR306D005	CR306D105	CR306D605	CR306D205	CR306D405
3	90	Separate control—115–120 V		CR306E002	CR306E102	CR306E602	CR306E202	CR306E402
3	90	200–208	25	CR306E023	CR306E123	CR306E623	CR306E223	CR306E423
3	90	230–240	30	CR306E003	CR306E103	CR306E603	CR306E203	CR306E403
3	90	460–480	50	CR306E004	CR306E104	CR306E604	CR306E204	CR306E404
3	90	575–600	50	CR306E005	CR306E105	CR306E605	CR306E205	CR306E405
4	135	Separate control—115–120 V		CR306F002	CR306F102	CR306F602	CR306F202	CR306F402
4	135	200–208	40	CR306F023	CR306F123	CR306F623	CR306F223	CR306F423
4	135	230–240	50	CR306F003	CR306F103	CR306F603	CR306F203	CR306F403
4	135	460–480	100	CR306F004	CR306F104	CR306F604	CR306F204	CR306F404
4	135	575–600	100	CR306F005	CR306F105	CR306F605	CR306F205	CR306F405
5	270	Separate control—115–120 V		CR306G002	CR306G102	CR306G602	CR306G202	CR306G402
5	270	200–208	75	CR306G023	CR306G123	CR306G623	CR306G223	CR306G423
5	270	230–240	100	CR306G003	CR306G103	CR306G603	CR306G203	CR306G403
5	270	460–480	200	CR306G004	CR306G104	CR306G604	CR306G204	CR306G404
5	270	575–600	200	CR306G005	CR306G105	CR306G605	CR306G205	CR306G405
6	540	Separate control—115–120 V		CR306HH002	CR306HH102	CR306HH602	CR306HH202	CR306HH402
6	540	200–208	150	CR306HH023	CR306HH123	CR306HH623	CR306HH223	CR306HH423
6	540	230–240	200	CR306HH003	CR306HH103	CR306HH603	CR306HH203	CR306HH403
6	540	460–480	400	CR306HH004	CR306HH104	CR306HH604	CR306HH204	CR306HH404
6	540	575–600	400	CR306HH005	CR306HH105	CR306HH605	CR306HH205	CR306HH405

¹Motor full load current should not exceed continuous ampere rating of the starter.

Please reference the [NEMA full voltage power devices catalog](#) for additional technical data, selection and installation guides, and dimensional drawings.

Open/enclosed non-combination magnetic starters

CR306 non-reversing with solid-state overload relay

NEMA sizes 1–6 with solid state overload relay
600 volts maximum
50/60 Hz



CR306CXE002

Ordering code selection instructions

- 50 Hz starters
50 Hz forms (at standard voltages) are the same as shown in table for 60 Hz. Refer to technical data for 380–415 volt horsepower ratings.
- Product notes
Motor full-load current should not exceed continuous ampere rating of starter.
- Note: Reversing, two-speed and combination starters are also available with solid-state overload relays.
- Units are individually boxed and poly-packed six per carton as standard.
- External reset not included on standard listed forms (NEMA Type 12).
- For additional details on the solid-state overload relay, refer to the overload relays section.

Features

- 2:1 adjustable full load amps with tactile feedback dial
- Selectable 10/20/30 protection class
- Ambient insensitive within the stated operating temperature range of -20 °C to +70 °C
- Built-in thermal memory to prevent hot motor restarts
- Protection against complete phase current loss
- Manual reset (standard) and remote reset (optional)
120 V AC
- Accuracy: $\pm 2\%$
- Repeatability: $\pm 2\%$
- Self-powered at 50% of minimum current range
- Size: 1–6 (0.40–540 A, 600 V, 50/60 Hz)
- Unbalance trip signal for PLC operation
- Manual trip
- Visual trip indication
- Standard isolated 1 NO and 1 NC auxiliary contact (A600, Q600)
- Built-in line/load straps
- Fits with existing 300-line starters
- Power factor correction terminals (sizes 1–4)
- DIN rail mountable sizes 1 and 2

Please reference the [NEMA full voltage power devices catalog](#) for additional technical data, selection and installation guides, and dimensional drawings.

Open/enclosed non-combination magnetic starters

CR306 non-reversing with solid-state overload relay

Includes a holding interlock, pressure terminals for the line and load connections, plus a solid-state overload relay (manual reset). Standard isolated 1 NO and 1 NC auxiliary contact (A600, Q600). Select current range from full load current selection table. Insert letter (C, D, E, F, etc.) from table on the next page, in ordering code to replace *.

Refer to empower configurator for other available starter coils and suffixes.

For NEMA size 0 and 00 applications, NEMA size 1 relay can be adjusted down to the proper amperage rating to fill 0–00 applications.

Three-phase magnetic starters

NEMA size	Continuous ampere rating ¹	Voltage	hp	Open type	NEMA type 1	NEMA type 3R	NEMA type 12 ²	NEMA type 4/4X
				Ordering code	Ordering code	Ordering code	Ordering code	Ordering code
1	27	Separate control — 115–120 V		CR306CX*002	CR306CX*102	CR306CX*602	CR306CX*202 ¹	CR306CX*402
1	27	200–208	7½	CR306CX*023	CR306CX*123	CR306CX*623	CR306CX*223 ¹	CR306CX*423
1	27	230–240	7½	CR306CX*003	CR306CX*103 ²	CR306CX*603	CR306CX*203 ¹	CR306CX*403
1	27	460–480	10	CR306CX*004	CR306CX*104	CR306CX*604	CR306CX*204 ¹	CR306CX*404
1	27	575–600	10	CR306CX*005	CR306CX*105	CR306CX*605	CR306CX*205 ¹	CR306CX*405
2	45	Separate control — 115–120 V		CR306DX*002	CR306DX*102	CR306DX*602	CR306DX*202 ¹	CR306DX*402
2	45	200–208	10	CR306DX*023	CR306DX*123	CR306DX*623	CR306DX*223 ¹	CR306DX*423
2	45	230–240	15	CR306DX*003	CR306DX*103	CR306DX*603	CR306DX*203 ¹	CR306DX*403
2	45	460–480	25	CR306DX*004	CR306DX*104	CR306DX*604	CR306DX*204 ¹	CR306DX*404
2	45	575–600	25	CR306DX*005	CR306DX*105	CR306DX*605	CR306DX*205 ¹	CR306DX*405
3	90	Separate control — 115–120 V		CR306EX*002	CR306EX*102	CR306EX*602	CR306EX*202 ¹	CR306EX*402
3	90	200–208	25	CR306EX*023	CR306EX*123	CR306EX*623	CR306EX*223 ¹	CR306EX*423
3	90	230–240	30	CR306EX*003	CR306EX*103	CR306EX*603	CR306EX*203 ¹	CR306EX*403
3	90	460–480	50	CR306EX*004	CR306EX*104	CR306EX*604	CR306EX*204 ¹	CR306EX*404
3	90	575–600	50	CR306EX*005	CR306EX*105	CR306EX*605	CR306EX*205 ¹	CR306EX*405
4	135	Separate control — 115–120 V		CR306FX*002	CR306FX*102	CR306FX*602	CR306FX*202 ¹	CR306FX*402
4	135	200–208	40	CR306FX*023	CR306FX*123	CR306FX*623	CR306FX*223 ¹	CR306FX*423
4	135	230–240	50	CR306FX*003	CR306FX*103	CR306FX*603	CR306FX*203 ¹	CR306FX*403
4	135	460–480	100	CR306FX*004	CR306FX*104	CR306FX*604	CR306FX*204 ¹	CR306FX*404
4	135	575–600	100	CR306FX*005	CR306FX*105	CR306FX*605	CR306FX*205 ¹	CR306FX*405
5	270	Separate control — 115–120 V		CR306GX*002	CR306GX*102	CR306GX*602	CR306GX*202 ¹	CR306GX*402
5	270	200–208	75	CR306GX*023	CR306GX*123	CR306GX*623	CR306GX*223 ¹	CR306GX*423
5	270	230–240	100	CR306GX*003	CR306GX*103	CR306GX*603	CR306GX*203 ¹	CR306GX*403
5	270	460–480	200	CR306GX*004	CR306GX*104	CR306GX*604	CR306GX*204 ¹	CR306GX*404
5	270	575–600	200	CR306GX*005	CR306GX*105	CR306GX*605	CR306GX*205 ¹	CR306GX*405
6	540	Separate control — 115–120 V		CR306HX*002	CR306HX*102	CR306HX*602	CR306HX*202 ¹	CR306HX*402
6	540	200–208	150	CR306HX*023	CR306HX*123	CR306HX*623	CR306HX*223 ¹	CR306HX*423
6	540	230–240	200	CR306HX*003	CR306HX*103	CR306HX*603	CR306HX*203 ¹	CR306HX*403
6	540	460–480	400	CR306HX*004	CR306HX*104	CR306HX*604	CR306HX*204 ¹	CR306HX*404
6	540	575–600	400	CR306HX*005	CR306HX*105	CR306HX*605	CR306HX*205 ¹	CR306HX*405

¹Motor full load current should not exceed continuous ampere rating of the starter.

²External reset not included on standard listed forms.

Please reference the [NEMA full voltage power devices catalog](#) for additional technical data, selection and installation guides, and dimensional drawings.

Open/enclosed non-combination magnetic starters

CR306 non-reversing with solid-state overload relay

Full load current selection table

For continuous rated motors, with a service factor of 1.15 to 1.25, select the heater with maximum motor amperes equal to or immediately greater than the motor full-load current (provides a maximum of 125% protection). For continuous rated motors with no service factor, multiply the full-load current of the motor by 0.90 and use this value to select the heater.

Overload range for solid-state starters	NEMA size	Fuse max.	Breaker max.	Insert digit in ordering code
0.4–0.85	00–1	3	15	C
0.8–1.7	00–1	6	15	D
1.6–3.4	00–1	12	15	E
3.2–6.8	00–1	25	25	F
6.5–13.5	00–1	50	50	G
13–27	00–1	100	100	H
6.5–13.5	2	50	50	G
13–27	2	100	100	H
25–50	2	200	200	J
17–35	3 and 4	125	125	K
35–70	3 and 4	250	250	L
65–135	3 and 4	500	400	M
35–70	5	–	–	N
65–135	5	500	400	P
130–270	5	600	800	Q
130–270	6	1200	800	S
260–540	6	1200	800	T

Please reference the [NEMA full voltage power devices catalog](#) for additional technical data, selection and installation guides, and dimensional drawings.

Open/enclosed non-combination magnetic starters

CR309 reversing with thermal overload relay

NEMA sizes 00–7 with thermal overload relay
600 volts maximum 50/60 Hz

For four-wire split phase or capacitor start induction motor (60 Hz) overload protection. One heater should be ordered as a separate item.

Single-phase magnetic reversing starters

NEMA size	Continuous ampere rating ¹	Voltage	hp	Open type	NEMA type 1	NEMA type 12 ²	NEMA type 4/4X ²
				Ordering code	Ordering code	Ordering code	Ordering code
00	9	115–120	1/3	CR309A002AFA	CR309A102AFA	–	–
00	9	230–240	1	CR309A003AFA	CR309A103AFA	–	–
0	18	115–120	1	CR309B002BBA	CR309B102DAA	CR309B202DAA	CR309B402CCA
0	18	230–240	2	CR309B003BBA	CR309B103DAA	CR309B203DAA	CR309B403CCA
1	27	115–120	2	CR309C002FSA	CR309C102DAA	CR309C202ALA	CR309C402BXA
1	27	230–240	3	CR309C003FSA	CR309C103DAA	CR309C203ALA	CR309C403BXA

¹Motor full load current should not exceed continuous ampere rating of the starter.

²External reset not included on standard listed forms.

Please reference the [NEMA full voltage power devices catalog](#) for additional technical data, selection and installation guides, and dimensional drawings.

Open/enclosed non-combination magnetic starters

CR309 reversing with thermal overload relay

NEMA sizes 00–7 with thermal overload relay
600 volts maximum 50/60 Hz

Includes a holding interlock, mechanical and cross-electrical interlock on each contactor, pressure terminals for the line and load connections, plus a 3-leg block type overload relay (manual reset). One NO isolated contact on the overload relay is available. To order, add suffix LAA to ordering codes listed in table for enclosed types and open forms.

Three-phase magnetic reversing starters

NEMA size	Continuous ampere rating ¹	Voltage (60 Hz)	hp	Open type w/ vertical mechanical interlock	Open type w/ horizontal mechanical interlock	NEMA type 1	NEMA type 3R	NEMA type 12 ²	NEMA type 4/4X
				Ordering code	Ordering code	Ordering code	Ordering code	Ordering code	Ordering code
00	9	Separate control — 115–120 V		–	CR309A002	CR309A102	–	–	–
00	9	200–208	1½	–	CR309A023	CR309A123	–	–	–
00	9	230–240	1½	–	CR309A003	CR309A103	–	–	–
00	9	460–480	2	–	CR309A004	CR309A104	–	–	–
00	9	575–600	2	–	CR309A005	CR309A105	–	–	–
0	18	Separate control — 115–120 V		CR309B002CAA	CR309B002	CR309B102	CR309B602	CR309B202	CR309B402
0	18	200–208	3	CR309B023CAA	CR309B023	CR309B123	CR309B623	CR309B223	CR309B423
0	18	230–240	3	CR309B003CAA	CR309B003	CR309B103	CR309B603	CR309B203	CR309B403
0	18	460–480	5	CR309B004CAA	CR309B004	CR309B104	CR309B604	CR309B204	CR309B404
0	18	575–600	5	CR309B005CAA	CR309B005	CR309B105	CR309B605	CR309B205	CR309B405
1	27	Separate control — 115–120 V		CR309C002CAA	CR309C002	CR309C102	CR309C602	CR309C202	CR309C402
1	27	200–208	7½	CR309C023CAA	CR309C023	CR309C123	CR309C623	CR309C223	CR309C423
1	27	230–240	7½	CR309C003CAA	CR309C003	CR309C103	CR309C603	CR309C203	CR309C403
1	27	460–480	10	CR309C004CAA	CR309C004	CR309C104	CR309C604	CR309C204	CR309C404
1	27	575–600	10	CR309C005CAA	CR309C005	CR309C105	CR309C605	CR309C205	CR309C405
2	45	Separate control — 115–120 V		CR309D002AMA	CR309D002	CR309D102	CR309D602	CR309D202	CR309D402
2	45	200–208	10	CR309D023AMA	CR309D023	CR309D123	CR309D623	CR309D223	CR309D423
2	45	230–240	15	CR309D003AMA	CR309D003	CR309D103	CR309D603	CR309D203	CR309D403
2	45	460–480	25	CR309D004AMA	CR309D004	CR309D104	CR309D604	CR309D204	CR309D404
2	45	575–600	25	CR309D005AMA	CR309D005	CR309D105	CR309D605	CR309D205	CR309D405
3	90	Separate control — 115–120 V		CR309E002AMA	CR309E002	CR309E102	CR309E602	CR309E202	CR309E402
3	90	200–208	25	CR309E023AMA	CR309E023	CR309E123	CR309E623	CR309E223	CR309E423
3	90	230–240	30	CR309E003AMA	CR309E003	CR309E103	CR309E603	CR309E203	CR309E403
3	90	460–480	50	CR309E004AMA	CR309E004	CR309E104	CR309E604	CR309E204	CR309E404
3	90	575–600	50	CR309E005AMA	CR309E005	CR309E105	CR309E605	CR309E205	CR309E405
4	135	Separate control — 115–120 V		CR309F002AMA	CR309F002	CR309F102	CR309F602	CR309F202	CR309F402
4	135	200–208	40	CR309F023AMA	CR309F023	CR309F123	CR309F623	CR309F223	CR309F423
4	135	230–240	50	CR309F003AMA	CR309F003	CR309F103	CR309F603	CR309F203	CR309F403
4	135	460–480	100	CR309F004AMA	CR309F004	CR309F104	CR309F604	CR309F204	CR309F404
4	135	575–600	100	CR309F005AMA	CR309F005	CR309F105	CR309F605	CR309F205	CR309F405
5	270	Separate control — 115–120 V		CR309G002AMA	CR309G002	CR309G102	CR309G602	CR309G202	CR309G402
5	270	200–208	75	CR309G023AMA	CR309G023	CR309G123	CR309G623	CR309G223	CR309G423
5	270	230–240	100	CR309G003AMA	CR309G003	CR309G103	CR309G603	CR309G203	CR309G403
5	270	460–480	200	CR309G004AMA	CR309G004	CR309G104	CR309G604	CR309G204	CR309G404
5	270	575–600	200	CR309G005AMA	CR309G005	CR309G105	CR309G605	CR309G205	CR309G405

¹Motor full load current should not exceed continuous ampere rating of the starter.

²External reset not included on standard listed forms.

Please reference the [NEMA full voltage power devices catalog](#) for additional technical data, selection and installation guides, and dimensional drawings.

Open/enclosed non-combination magnetic starters

CR309 2-speed starters

200 horsepower maximum
NEMA Sizes 0–5,
600 volts maximum
50/60 Hz



CR309C002BAA

Used for full-voltage operation of two-speed squirrel-cage induction motors at either speed. Consists of two mechanical and cross-electrical interlocked contactors with two three-leg block type overload relays, one on each contactor. These bimetallic relays provide overload protection for each speed. 3-3 pole starters are for two-speed, two winding motors; 5-3 pole starters are for two-speed, one-winding consequent pole motors.

Proper motor-speed selection is obtained by adding pilot devices to correspond to each of the motor speeds.

Please reference the [NEMA full voltage power devices catalog](#) for additional technical data, selection and installation guides, and dimensional drawings.

Open/enclosed non-combination magnetic starters

CR309 2-speed starters

Two-speed, two-winding, 3-3 pole
Non-combination, open, NEMA type 1, 3R, 12, 4/4X
NEMA sizes 0–5 with thermal overload relay
600 volts maximum 50/60 hertz

Three-phase
 Includes a holding interlock, mechanical and cross-electrical interlock, pressure terminals for the line and load connections, plus a 3-leg block type overload relay (manual reset) for each speed. All enclosures include external reset. One NO isolated contact on each overload relay is available as an option. To order, change suffix AKA to LKA for ordering codes listed in table. Six heaters should be ordered as separate items. The ordering codes listed are starters suitable for wye or closed delta connected motor windings.

Three-phase two-winding magnetic starters

NEMA size	Continuous ampere rating ¹	Voltage (60 Hz)	hp	Open type	NEMA type 1	NEMA type 3R	NEMA type 12	NEMA type 4/4X
				Ordering code	Ordering code	Ordering code	Ordering code	Ordering code
0	18	Separate control—115-120 V		CR309B002AKA	CR309B102AKA	CR309B602AKA	CR309B202AKA	CR309B402AKA
0	18	200-208	3	CR309B023AKA	CR309B123AKA	CR309B623AKA	CR309B223AKA	CR309B423AKA
0	18	230-240	3	CR309B003AKA	CR309B103AKA	CR309B603AKA	CR309B203AKA	CR309B403AKA
0	18	460-480	5	CR309B004AKA	CR309B104AKA	CR309B604AKA	CR309B204AKA	CR309B404AKA
0	18	575-600	5	CR309B005AKA	CR309B105AKA	CR309B605AKA	CR309B205AKA	CR309B405AKA
1	27	Separate control—115-120 V		CR309C002AKA	CR309C102AKA	CR309C602AKA	CR309C202AKA	CR309C402AKA
1	27	200-208	7½	CR309C023AKA	CR309C123AKA	CR309C623AKA	CR309C223AKA	CR309C423AKA
1	27	230-240	7½	CR309C003AKA	CR309C103AKA	CR309C603AKA	CR309C203AKA	CR309C403AKA
1	27	460-480	10	CR309C004AKA	CR309C104AKA	CR309C604AKA	CR309C204AKA	CR309C404AKA
1	27	575-600	10	CR309C005AKA	CR309C105AKA	CR309C605AKA	CR309C205AKA	CR309C405AKA
2	45	Separate control—115-120 V		CR309D002AKA	CR309D102AKA	CR309D602AKA	CR309D202AKA	CR309D402AKA
2	45	200-208	10	CR309D023AKA	CR309D123AKA	CR309D623AKA	CR309D223AKA	CR309D423AKA
2	45	230-240	15	CR309D003AKA	CR309D103AKA	CR309D603AKA	CR309D203AKA	CR309D403AKA
2	45	460-480	25	CR309D004AKA	CR309D104AKA	CR309D604AKA	CR309D204AKA	CR309D404AKA
2	45	575-600	25	CR309D005AKA	CR309D105AKA	CR309D605AKA	CR309D205AKA	CR309D405AKA
3	90	Separate control—115-120 V		CR309E002AKA	CR309E102AKA	CR309E602AKA	CR309E202AKA	CR309E402AKA
3	90	200-208	25	CR309E023AKA	CR309E123AKA	CR309E623AKA	CR309E223AKA	CR309E423AKA
3	90	230-240	30	CR309E003AKA	CR309E103AKA	CR309E603AKA	CR309E203AKA	CR309E403AKA
3	90	460-480	50	CR309E004AKA	CR309E104AKA	CR309E604AKA	CR309E204AKA	CR309E404AKA
3	90	575-600	50	CR309E005AKA	CR309E105AKA	CR309E605AKA	CR309E205AKA	CR309E405AKA
4	135	Separate control—115-120 V		CR309F002AKA	CR309F102AKA	CR309F602AKA	CR309F202AKA	CR309F402AKA
4	135	200-208	40	CR309F023AKA	CR309F123AKA	CR309F623AKA	CR309F223AKA	CR309F423AKA
4	135	230-240	50	CR309F003AKA	CR309F103AKA	CR309F603AKA	CR309F203AKA	CR309F403AKA
4	135	460-480	100	CR309F004AKA	CR309F104AKA	CR309F604AKA	CR309F204AKA	CR309F404AKA
4	135	575-600	100	CR309F005AKA	CR309F105AKA	CR309F605AKA	CR309F205AKA	CR309F405AKA
5	270	Separate control—115-120 V		CR309G002AKA	CR309G102AKA	CR309G602AKA	CR309G202AKA	CR309G402AKA
5	270	200-208	75	CR309G023AKA	CR309G123AKA	CR309G623AKA	CR309G223AKA	CR309G423AKA
5	270	230-240	100	CR309G003AKA	CR309G103AKA	CR309G603AKA	CR309G203AKA	CR309G403AKA
5	270	460-480	200	CR309G004AKA	CR309G104AKA	CR309G604AKA	CR309G204AKA	CR309G404AKA
5	270	575-600	200	CR309G005AKA	CR309G105AKA	CR309G605AKA	CR309G205AKA	CR309G405AKA

¹Motor full load current should not exceed continuous ampere rating of the starter.

Please reference the [NEMA full voltage power devices catalog](#) for additional technical data, selection and installation guides, and dimensional drawings.

Open/enclosed non-combination magnetic starters

CR309 2-speed starters

**Two-speed, one-winding (consequent pole), 5-3 pole
Non-combination, open, NEMA type 1, 3R, 12, 4/4X
NEMA sizes 0-5 with thermal overload relay
600 volts maximum 50/60 hertz**

Three-phase
Includes a holding interlock, mechanical and cross-electrical interlock, pressure terminals for the line and load connections, plus a 3-leg block type overload relay (manual reset) for each speed. All enclosures include external reset. One NO isolated contact on each overload relay is available as an option. To order, change suffix AKA to LKA for ordering codes listed in table. Six heaters should be ordered as separate items. Starters are wired for constant or variable torque motor application. Reconnection of control wiring may be required for constant horsepower application. Motor full-load current should not exceed continuous ampere rating of starter.

Three-phase one-winding magnetic starters

NEMA size	Continuous ampere rating ¹	Voltage (60 Hz)	hp	Open type	NEMA type 1	NEMA type 3R	NEMA type 12	NEMA type 4/4X
				Ordering code	Ordering code	Ordering code	Ordering code	Ordering code
0	18	Separate control—115-120 V		CR309R002AEA	CR309R102AEA	CR309R602AEA	CR309R202AEA	CR309R402AEA
0	18	200-208	3	CR309R023AEA	CR309R123AEA	CR309R623AEA	CR309R223AEA	CR309R423AEA
0	18	230-240	3	CR309R003AEA	CR309R103AEA	CR309R603AEA	CR309R203AEA	CR309R403AEA
0	18	460-480	5	CR309R004AEA	CR309R104AEA	CR309R604AEA	CR309R204AEA	CR309R404AEA
0	18	575-600	5	CR309R005AEA	CR309R105AEA	CR309R605AEA	CR309R205AEA	CR309R405AEA
1	27	Separate control—115-120 V		CR309S002AEA	CR309S102AEA	CR309S602AEA	CR309S202AEA	CR309S402AEA
1	27	200-208		CR309S023AEA	CR309S123AEA	CR309S623AEA	CR309S223AEA	CR309S423AEA
1	27	230-240	7½	CR309S003AEA	CR309S103AEA	CR309S603AEA	CR309S203AEA	CR309S403AEA
1	27	460-480	10	CR309S004AEA	CR309S104AEA	CR309S604AEA	CR309S204AEA	CR309S404AEA
1	27	575-600	10	CR309S005AEA	CR309S105AEA	CR309S605AEA	CR309S205AEA	CR309S405AEA
2	45	Separate control—115-120 V		CR309T002AEA	CR309T102AEA	CR309T602AEA	CR309T202AEA	CR309T402AEA
2	45	200-208	10	CR309T023AEA	CR309T123AEA	CR309T623AEA	CR309T223AEA	CR309T423AEA
2	45	230-240	15	CR309T003AEA	CR309T103AEA	CR309T603AEA	CR309T203AEA	CR309T403AEA
2	45	460-480	25	CR309T004AEA	CR309T104AEA	CR309T604AEA	CR309T204AEA	CR309T404AEA
2	45	575-600	25	CR309T005AEA	CR309T105AEA	CR309T605AEA	CR309T205AEA	CR309T405AEA
3	90	Separate control—115-120 V		CR309U002AEA	CR309U102AEA	CR309U602AEA	CR309U202AEA	CR309U402AEA
3	90	200-208	25	CR309U023AEA	CR309U123AEA	CR309U623AEA	CR309U223AEA	CR309U423AEA
3	90	230-240	30	CR309U003AEA	CR309U103AEA	CR309U603AEA	CR309U203AEA	CR309U403AEA
3	90	460-480	50	CR309U004AEA	CR309U104AEA	CR309U604AEA	CR309U204AEA	CR309U404AEA
3	90	575-600	50	CR309U005AEA	CR309U105AEA	CR309U605AEA	CR309U205AEA	CR309U405AEA
4	135	Separate control—115-120 V		CR309W002AEA	CR309W102AEA	CR309W602AEA	CR309W202AEA	CR309W402AEA
4	135	200-208	40	CR309W023AEA	CR309W123AEA	CR309W623AEA	CR309W223AEA	CR309W423AEA
4	135	230-240	50	CR309W003AEA	CR309W103AEA	CR309W603AEA	CR309W203AEA	CR309W403AEA
4	135	460-480	100	CR309W004AEA	CR309W104AEA	CR309W604AEA	CR309W204AEA	CR309W404AEA
4	135	575-600	100	CR309W005AEA	CR309W105AEA	CR309W605AEA	CR309W205AEA	CR309W405AEA
5	270	Separate control—115-120 V		CR309Z002AEA	CR309Z102AEA	CR309Z602AEA	CR309Z202AEA	CR309Z402AEA
5	270	200-208	75	CR309Z023AEA	CR309Z123AEA	CR309Z623AEA	CR309Z223AEA	CR309Z423AEA
5	270	230-240	100	CR309Z003AEA	CR309Z103AEA	CR309Z603AEA	CR309Z203AEA	CR309Z403AEA
5	270	460-480	200	CR309Z004AEA	CR309Z104AEA	CR309Z604AEA	CR309Z204AEA	CR309Z404AEA
5	270	575-600	200	CR309Z005AEA	CR309Z105AEA	CR309Z605AEA	CR309Z205AEA	CR309Z405AEA

¹Motor full load current should not exceed continuous ampere rating of the starter.

Please reference the [NEMA full voltage power devices catalog](#) for additional technical data, selection and installation guides, and dimensional drawings.

Enclosed combination magnetic starters

CR307, CR407, CR308, CR408 non-reversing product overview

400 horsepower maximum
NEMA sizes 0–6
600 volts maximum
50/60 Hz



CR307 enclosed combination starter

These combination starters are used for full voltage starting of single-speed squirrel-cage induction motors up to 400 horsepower maximum, 600 volts maximum. Each starter provides short-circuit protection by means of a fusible disconnect, a thermal magnetic trip circuit breaker, or circuit interrupter function with a non-fusible disconnect switch.

Features

- Branch circuit protection — is provided by means of a disconnect switch or molded case circuit breaker.
- Mechanism — always controls interrupting switch.
- Easy inspection, maintenance — performed from starter front.
- LED lights standard.
- Optional factory-installed control transformer.

Please reference the [NEMA full voltage power devices catalog](#) for additional technical data, selection and installation guides, and dimensional drawings.

Enclosed combination magnetic starters

CR307, CR407 non-reversing, thermal magnetic circuit breaker

NEMA sizes 0–6, thermal magnetic circuit breaker type
600 volts maximum 50/60 Hz

Standard features

Tmax® XT circuit breaker. Includes a holding interlock, pressure terminals for the line and load connections, plus a 3-leg block type ambient compensated overload relay with manual reset. All enclosures include external reset. NO/NC contacts on the overload relay are provided. LED lights standard.

Thermal magnetic circuit breaker type

Voltage (60 Hz)	NEMA size	Max. hp	Continuous amp rating	CB rating (amps)	NEMA type 1		NEMA type 3R		NEMA type 12		NEMA type 4/4X	
					Ordering code	Ordering code	Ordering code	Ordering code				
200–208	0	2	18	15	CR307BT08TC4AAAAA	CR407B608TC4AAAAA	CR407B208TC4AAAAA	CR407B408TC4AAAAA				
200–208	0	3	18	20	CR307BT08TD4AAAAA	CR407B608TD4AAAAA	CR407B208TD4AAAAA	CR407B408TD4AAAAA				
200–208	1	5	27	30	CR307CT08TF4AAAAA	CR407C608TF4AAAAA	CR407C208TF4AAAAA	CR407C408TF4AAAAA				
200–208	1	7½	27	40	CR307CT08TG4AAAAA	CR407C608TG4AAAAA	CR407C208TG4AAAAA	CR407C408TG4AAAAA				
200–208	2	10	45	50	CR307DT08TH4AAAAA	CR407D608TH4AAAAA	CR407D208TH4AAAAA	CR407D408TH4AAAAA				
200–208	3	15	90	80	CR407E108TL4AAAAA	CR407E608TL4AAAAA	CR407E208TL4AAAAA	CR407E408TL4AAAAA				
200–208	3	20	90	100	CR407E108TN4AAAAA	CR407E608TN4AAAAA	CR407E208TN4AAAAA	CR407E408TN4AAAAA				
200–208	3	25	90	125	CR407E108TQ4AAAAA	CR407E608TQ4AAAAA	CR407E208TQ4AAAAA	CR407E408TQ4AAAAA				
200–208	4	30	135	150	CR407F108TR4AAAAA	CR407E608TR4AAAAA	CR407F208TR4AAAAA	CR407F408TR4AAAAA				
200–208	4	40	135	200	CR407F108TT4AAAAA	CR407F608TT4AAAAA	CR407F208TT4AAAAA	CR407F408TT4AAAAA				
230–240	0	3	18	15	CR307BT03TC4AAAAA	CR407B603TC4AAAAA	CR407B203TC4AAAAA	CR407B403TC4AAAAA				
230–240	1	5	27	25	CR307CT03TE4AAAAA	CR407C603TE4AAAAA	CR407C203TE4AAAAA	CR407C403TE4AAAAA				
230–240	1	7½	27	40	CR307CT03TG4AAAAA	CR407C603TG4AAAAA	CR407C203TG4AAAAA	CR407C403TG4AAAAA				
230–240	2	10	45	50	CR307DT03TH4AAAAA	CR407D603TH4AAAAA	CR407D203TH4AAAAA	CR407D403TH4AAAAA				
230–240	2	15	45	70	CR307DT03TK4AAAAA	CR407D603TK4AAAAA	CR407D203TK4AAAAA	CR407D403TK4AAAAA				
230–240	3	20	90	90	CR407E103TM4AAAAA	CR407E603TM4AAAAA	CR407E203TM4AAAAA	CR407E403TM4AAAAA				
230–240	3	25	90	110	CR407E103TP4AAAAA	CR407E603TP4AAAAA	CR407E203TP4AAAAA	CR407E403TP4AAAAA				
230–240	3	30	90	125	CR407E103TQ4AAAAA	CR407E603TQ4AAAAA	CR407E203TQ4AAAAA	CR407E403TQ4AAAAA				
230–240	4	40	135	175	CR407F103TS4AAAAA	CR407F603TS4AAAAA	CR407F203TS4AAAAA	CR407F403TS4AAAAA				
230–240	4	50	135	200	CR407F103TT4AAAAA	CR407F603TT4AAAAA	CR407F203TT4AAAAA	CR407F403TT4AAAAA				
460–480	0	5	18	15	CR307BT04TC4AAAAA	CR407B604TC4AAAAA	CR407B204TC4AAAAA	CR407B404TC4AAAAA				
460–480	1	7½	27	20	CR307CT04TD4AAAAA	CR407C604TD4AAAAA	CR407C204TD4AAAAA	CR407C404TD4AAAAA				
460–480	1	10	27	25	CR307CT04TE4AAAAA	CR407C604TE4AAAAA	CR407C204TE4AAAAA	CR407C404TE4AAAAA				
460–480	2	15	45	40	CR307DT04TG4AAAAA	CR407D604TG4AAAAA	CR407D204TG4AAAAA	CR407D404TG4AAAAA				
460–480	2	20	45	50	CR307DT04TH4AAAAA	CR407D604TH4AAAAA	CR407D204TH4AAAAA	CR407D404TH4AAAAA				
460–480	2	25	45	60	CR307DT04TJ4AAAAA	CR407D604TJ4AAAAA	CR407D204TJ4AAAAA	CR407D404TJ4AAAAA				
460–480	3	30	90	60	CR407E104TJ4AAAAA	CR407E604TJ4AAAAA	CR407E204TJ4AAAAA	CR407E404TJ4AAAAA				
460–480	3	40	90	80	CR407E104TL4AAAAA	CR407E604TL4AAAAA	CR407E204TL4AAAAA	CR407E404TL4AAAAA				
460–480	3	50	90	100	CR407E104TN4AAAAA	CR407E604TN4AAAAA	CR407E204TN4AAAAA	CR407E404TN4AAAAA				
460–480	4	60	135	125	CR407E104TQ4AAAAA	CR407E604TQ4AAAAA	CR407E204TQ4AAAAA	CR407E404TQ4AAAAA				
460–480	4	75	135	150	CR407F104TR4AAAAA	CR407F604TR4AAAAA	CR407F204TR4AAAAA	CR407F404TR4AAAAA				
460–480	4	100	135	200	CR407F104TT4AAAAA	CR407F604TT4AAAAA	CR407F204TT4AAAAA	CR407F404TT4AAAAA				
575–600	0	5	18	15	CR407F104TT4AAAAA	CR407B605TC4AAAAA	CR407B205TC4AAAAA	CR407B405TC4AAAAA				
575–600	1	7 ½	27	15	CR407F104TT4AAAAA	CR407C605TC4AAAAA	CR407C205TC4AAAAA	CR407C405TC4AAAAA				
575–600	1	10	27	20	CR407F104TT4AAAAA	CR407C605TD4AAAAA	CR407C205TD4AAAAA	CR407C405TD4AAAAA				
575–600	2	15	45	30	CR407F104TT4AAAAA	CR407D605TF4AAAAA	CR407D205TF4AAAAA	CR407D405TF4AAAAA				
575–600	2	20	45	40	CR407F104TT4AAAAA	CR407D605TG4AAAAA	CR407D205TG4AAAAA	CR407D405TG4AAAAA				
575–600	2	25	45	50	CR407F104TT4AAAAA	CR407D605TH4AAAAA	CR407D205TH4AAAAA	CR407D405TH4AAAAA				
575–600	3	30	90	50	CR407E105TH4AAAAA	CR407E605TH4AAAAA	CR407E205TH4AAAAA	CR407E405TH4AAAAA				
575–600	3	40	90	70	CR407E105TH4AAAAA	CR407E605TK4AAAAA	CR407E205TK4AAAAA	CR407E405TK4AAAAA				
575–600	3	50	90	80	CR407E105TL4AAAAA	CR407E605TL4AAAAA	CR407E205TL4AAAAA	CR407E405TL4AAAAA				
575–600	4	60	135	100	CR407F105TN4AAAAA	CR407F605TN4AAAAA	CR407F205TN4AAAAA	CR407F405TN4AAAAA				
575–600	4	75	135	125	CR407F105TQ4AAAAA	CR407F605TQ4AAAAA	CR407F205TQ4AAAAA	CR407F405TQ4AAAAA				
575–600	4	100	135	150	CR407F105TQ4AAAAA	CR407F605TR4AAAAA	CR407F205TR4AAAAA	CR407F405TR4AAAAA				

• NEMA size 0–4 starters with 115–120 volt, 60 Hz coil for separate control are available. To order, replace digits 8 and 9 of listed ordering codes with 02.

Example: CR407B604TC1AAAAA with 115–120 volt, 60 Hz coil for separate control becomes CR407B602TC1AAAAA.

• Motor full load current should not exceed continuous ampere rating of starter.

Enclosed combination magnetic starters

CR307 non-reversing, thermal magnetic circuit breaker

Ordering code configuration

Valid for NEMA sizes 0–2, type 1 standard enclosure

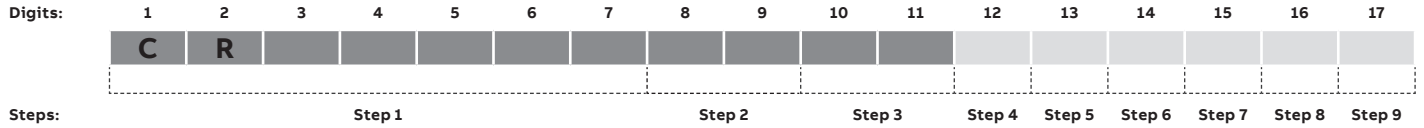

To configure the ordering code, use the tables below to fill in the digit boxes with the appropriate code.

Step 1 (digits 1–7) select NEMA size and enclosure

NEMA size	NEMA type 1 Standard enclosure
0	CR307BT
1	CR307CT
2	CR307DT

Note: All enclosures include external overload reset buttons.

Step 2 (digits 8, 9) select control voltage

Control circuit voltage and CPT	No CPT	Control fuses, no CPT	Standard size CPT	Standard size CPT + 100 VA
120 V with surge protector (SP)	01	F1	–	–
120 V	02	F2	–	–
240 V	03	F3	–	–
480 V	04	F4	–	–
600 V	05	F5	–	–
208 V	08	F8	–	–
24 V	09	–	–	–
240 V/120 V with CPT	–	–	93	13
480 V/120 V with CPT	–	–	94	14
600 V/120 V with CPT	–	–	95	15
208 V/120 V with CPT	–	–	98	18
240 V/120 V with CPT and SP	–	–	33	53
480 V/120 V with CPT and SP	–	–	34	54
600 V/120 V with CPT and SP	–	–	35	55
208 V/120 V with CPT and SP	–	–	38	58
240 V/24 V with CPT	–	–	S3	A3
480 V/24 V with CPT	–	–	S4	A4
600 V/24 V with CPT	–	–	S5	A5
208 V/24 V with CPT	–	–	S8	A8

Note: CPT includes 2 primary fuses and 1 secondary fuse.

Step 3 (digits 10, 11) select protective device

Thermal magnetic circuit breaker

NEMA size	200–208 V			240 V			480 V			600 V		
	Max. hp	CB rating (amps)	Code	Max. hp	CB rating (amps)	Code	Max. hp	CB rating (amps)	Code	Max. hp	CB rating (amps)	Code
0	2	15	TC	3	15	TC	5	15	TC	5	15	TC
	3	15	TC	–	–	–	–	–	–	–	–	–
1	–	–	–	–	–	–	–	–	–	7½	15	TC
	5	25	TE	5	25	TE	7½	25	TE	–	–	–
	–	–	–	–	–	–	–	–	–	10	25	TE
2	7½	40	TG	7½	40	TG	10	25	TE	10	20	TD
	–	–	–	–	–	–	15	40	TG	15	40	TG
	10	60	TJ	10	60	TJ	–	–	–	–	–	–
	–	–	–	–	–	–	–	–	–	20	40	TG
	–	–	–	15	60	TJ	20	60	TJ	–	–	–
–	–	–	–	–	–	25	60	TJ	25	60	TJ	

Enclosed combination magnetic starters

CR307 non-reversing, thermal magnetic circuit breaker

Ordering code configuration

Valid for NEMA sizes 0–2, type 1 standard enclosure

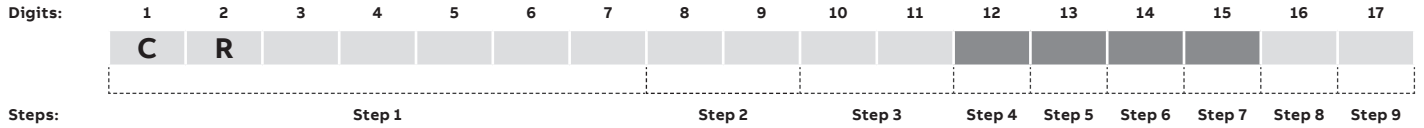

To configure the ordering code, use the tables below to fill in the digit boxes with the appropriate code.

Step 4 (digit 12) select overload relay

Overload relay	Code
Thermal bi-metallic ambient compensated (1 NC)	3
Thermal bi-metallic ambient compensated (1 NO–1 NC)	4
Solid state overload (1 NO–1 NC)	(#)

(#) Select code for solid state overload amp rating from standard or optional ranges table below.

Solid state overload relay — standard range

NEMA size	200–208 V		230–240 V		460–480 V		575–600 V		
	OL range	Max. hp	Code	Max. hp	Code	Max. hp	Code	Max. hp	Code
0	0.8–1.7	–	–	–	–	3/4	D	1	D
	1.6–3.4	½	E	¾	E	2	E	2	E
	3.2–6.8	1	F	2	F	3	F	5	F
	6.5–13.5	3	G	3	G	5	G	–	–
1	6.5–13.5	–	–	–	–	7½	G	10	G
	13–27	7½	H	7½	H	10	H	–	–
2	13–27	–	–	–	–	20	H	25	H
	25–50	10	J	15	J	25	J	–	–

Optional ranges

OL amp range	NEMA size	
	0 and 1	2
0.4–0.85	C	–
0.8–1.7	D	–
1.6–3.4	E	–
3.2–6.8	F	–
6.5–13.5	G	G
13–27	H	H
25–50	–	J
17–35	–	–
35–70	–	–
65–135	–	–

Step 5 (digit 13) select auxiliary contacts

Auxiliary contacts	Code
None	A
1 NO	B
1 NC	C
1 NO–1 NC	D
2 NO	E
2 NC	F
2 NO–1 NC	G
1 NO–2 NC	H
3 NO	J
3 NC	K
4 NO	L ¹
4 NC	M ¹
2 NO–2 NC	N ¹
3 NO–1 NC	P ¹
1 NO–3 NC	R ¹

¹Exceeds maximum number of contacts for some pilot light selections. See step 8 (digit 16)

Step 6 (digit 14) select monitoring options

Device	Code
None ²	A

²Phase failure relay is not available for CR307 series standard enclosures. If this is required for your application, use CR407 series oversized enclosure.

Step 7 (digit 15) select pushbutton/selector switch

Pushbutton/selector switch — heavy duty	Code
None	A
Start/stop pushbutton	J
Hand-off-auto (HOA) selector switch	L
Off-on selector switch	M
HOA selector switch and start pushbutton	S
Keyed HOA selector switch, key removal center pos.	N

Enclosed combination magnetic starters

CR307 non-reversing, thermal magnetic circuit breaker

Ordering code configuration

Valid for NEMA sizes 0–2, type 1 standard enclosure

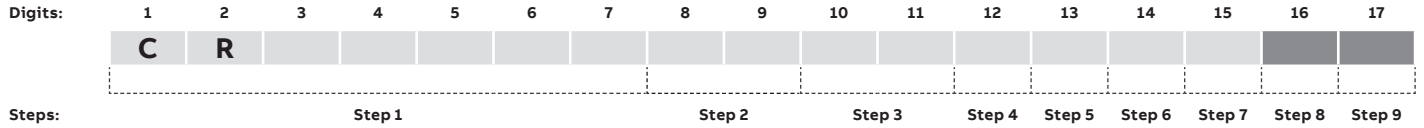

To configure the ordering code, use the tables below to fill in the digit boxes with the appropriate code.

Step 8 (digit 16) select pilot device

Pilot light (heavy duty) type	Color — functionality	Code
None		A
LED lights	Red — across coil	1
	Green — across coil	2
	Red — thru NO aux contact	3 ³
	Green — thru NC aux contact	4 ³
	Red — thru NO aux contact and green — thru NC aux contact	5 ⁴
	Red — across coil and green — thru NC aux contact	6 ³
	Red — across coil and green — thru NC aux contact and unwired amber	7 ³
Push-to-test lights	Red — across coil	R
	Green — across coil	S
	Red — thru NO aux contact	C ³
	Green — thru NC aux contact	D ³
	Red — thru NO aux contact and green — thru NC aux contact	E ⁴
	Red — across coil and green — thru NC aux contact	V ³
	Red — across coil and green — thru NC aux contact and unwired amber	Y ³

³Maximum of 3 aux contacts may be added to sizes 0 and 1.

⁴Maximum of 2 aux contacts may be added to sizes 0 and 1. Maximum of 3 aux contacts may be added to sizes 2-4.

Note: Auxiliary contacts wired as part of pilot light selection are in addition to the auxiliary contacts selected from Step 5 (digit 13), which are for customer/field connections.

Step 9 (digit 17) select control options

Device	Code
None	A

General note:

On NEMA size 3 and 4 starters, if selecting factory installed and wired operator devices (pushbuttons, selector switches and/or pilot lights), then control circuit fusing, a control power transformer or 120 V separate sourced control is required when the protective device is rated greater than 100 amps.

Please reference the [NEMA full voltage power devices catalog](#) for additional technical data, selection and installation guides, and dimensional drawings.

Enclosed combination magnetic starters

CR407 non-reversing, thermal magnetic circuit breaker

Ordering code configuration

Valid for NEMA sizes 0–4

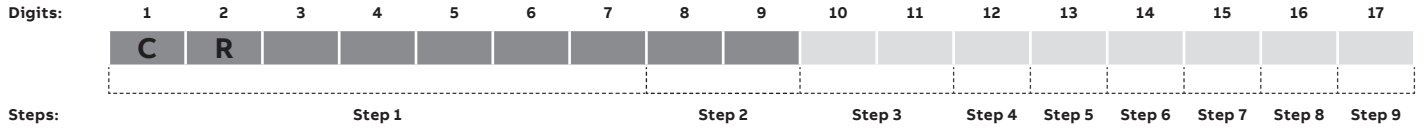

To configure the ordering code, use the tables below to fill in the digit boxes with the appropriate code.

Step 1 (digits 1–7) select NEMA size and enclosure

NEMA size	NEMA type 1		NEMA type 3R		NEMA type 12		NEMA type 4/4X	
	Standard enclosure	Oversized enclosure	Standard enclosure	Oversized enclosure	Standard enclosure	Oversized enclosure	Standard enclosure	Oversized enclosure
0	Use CR307	CR407B5	CR407B6	CR407BR	CR407B2	CR407B7	CR407B4	CR407B5
1	Use CR307	CR407C5	CR407C6	CR407CR	CR407C2	CR407C7	CR407C4	CR407CS
2	Use CR307	CR407D5	CR407D6	CR407DR	CR407D2	CR407D7	CR407D4	CR407DS
3	CR407E1	CR407E5	CR407E6	CR407ER	CR407E2	CR407E7	CR407E4	CR407ES
4	CR407F1	CR407F5	CR407F6	CR407FR	CR407F2	CR407F7	CR407F4	CR407FS

Note: All enclosures include external overload reset buttons. NEMA type 4/4X enclosures are type 304 stainless steel.

Step 2 (digits 8, 9) select control voltage (no CPT and standard size CPT)

Control circuit voltage and CPT	Control fuses, no CPT		Standard size CPT
	No CPT		
120 V with surge protector (SP)	01	F1	–
120 V	02	F2	–
240 V	03	F3	–
480 V	04	F4	–
600 V	05	F5	–
208 V	08	F8	–
24 V ¹	09	–	–
240 V/120 V with CPT	–	–	93
480 V/120 V with CPT	–	–	94
600 V/120 V with CPT	–	–	95
208 V/120 V with CPT	–	–	98
240 V/120 V with CPT and SP	–	–	33
480 V/120 V with CPT and SP	–	–	34
600 V/120 V with CPT and SP	–	–	35
208 V/120 V with CPT and SP	–	–	38
240 V/24 V with CPT ¹	–	–	S3
480 V/24 V with CPT ¹	–	–	S4
600 V/24 V with CPT ¹	–	–	S5
208 V/24 V with CPT ¹	–	–	S8

Step 2 (digits 8, 9) select control voltage (extra capacity CPT + 100 VA and 200 VA)

Control circuit voltage and CPT	Standard size CPT + 100 VA	Standard size CPT + 200 VA
	120 V with surge protector (SP)	–
120 V	–	–
240 V	–	–
480 V	–	–
600 V	–	–
208 V	–	–
24 V ¹	–	–
240 V/120 V with CPT	13	23
480 V/120 V with CPT	14	24
600 V/120 V with CPT	15	25
208 V/120 V with CPT	18	28
240 V/120 V with CPT and SP	53	63
480 V/120 V with CPT and SP	54	64
600 V/120 V with CPT and SP	55	65
208 V/120 V with CPT and SP	58	68
240 V/24 V with CPT ¹	A3	B3
480 V/24 V with CPT ¹	A4	B4
600 V/24 V with CPT ¹	A5	B5
208 V/24 V with CPT ¹	A8	B8

Note: CPT includes 2 primary fuses and 1 secondary fuse.

¹24 V coils not available for NEMA size 3 and 4.

²Requires oversized enclosure for NEMA sizes 0–2. Select proper NEMA size and enclosure type from step 1 (digits 1–7) table.

Please reference the [NEMA full voltage power devices catalog](#) for additional technical data, selection and installation guides, and dimensional drawings.

Enclosed combination magnetic starters

CR407 non-reversing, thermal magnetic circuit breaker

Ordering code configuration

Valid for NEMA sizes 0-4

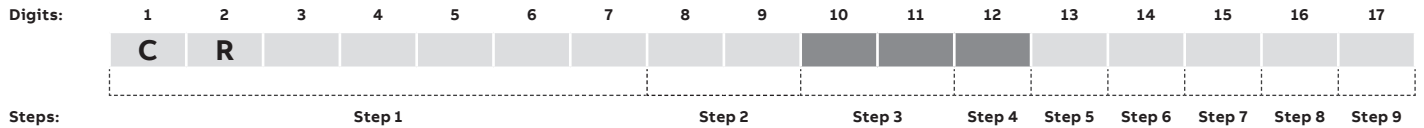

To configure the ordering code, use the tables below to fill in the digit boxes with the appropriate code.

Step 3 (digits 10, 11) select protective device

Thermal magnetic circuit breaker

NEMA size	200-208 V			240 V			480 V			600 V		
	Max. hp	CB rating (amps)	Code	Max. hp	CB rating (amps)	Code	Max. hp	CB rating (amps)	Code	Max. hp	CB rating (amps)	Code
0	2	15	TC	3	15	TC	5	15	TC	5	15	TC
	3	15	TC	-	-	-	-	-	-	-	-	-
1	-	-	-	-	-	-	-	-	-	7½	15	TC
	5	25	TE	5	25	TE	7½	25	TE	-	-	-
	-	-	-	-	-	-	-	-	-	10	25	TE
2	7½	40	TG	7½	40	TG	10	25	TE	10	20	TD
	-	-	-	-	-	-	15	40	TG	15	40	TG
	10	60	TJ	10	60	TJ	-	-	-	-	-	-
	-	-	-	-	-	-	-	-	-	20	40	TG
3	-	-	-	15	60	TJ	20	60	TJ	-	-	-
	-	-	-	-	-	-	25	60	TJ	25	60	TJ
	-	-	-	-	-	-	30	60	TJ	30	60	TJ
	15	100	TN	20	100	TN	-	-	-	-	-	-
4	-	-	-	-	-	-	-	-	-	40	60	TJ
	20	100	TN	25	100	TN	40	100	TN	-	-	-
	-	-	-	-	-	-	50	100	TN	50	100	TN
	25	125	TQ	30	125	TQ	-	-	-	-	-	-
	30	150	TR	-	-	-	60	150	TR	60	150	TR
4	-	-	-	40	200	TT	-	-	-	-	-	-
	-	-	-	-	-	-	75	150	TR	75	150	TR
	40	200	TT	50	200	TT	-	-	-	-	-	-
-	-	-	-	-	-	100	200	TT	100	200	TT	

Step 4 (digit 12) select overload relay

Overload relay	Code
Thermal bi-metallic ambient compensated (1 NC)	3
Thermal bi-metallic ambient compensated (1 NO-1 NC)	4
Solid state overload (1 NO-1 NC)	(#)

(#) Select code for solid state overload amp rating from standard or optional ranges below.

Solid state overload relay - standard range

NEMA size	200-208 V		230-240 V		460-480 V		575-600 V	
	OL range	Max. hp	Code	Max. hp	Code	Max. hp	Code	
0	0.8-1.7	-	-	-	-	3/4	D	
	1.6-3.4	1/2	E	3/4	E	2	E	
	3.2-6.8	1	F	2	F	3	F	
	6.5-13.5	3	G	3	G	5	G	
1	6.5-13.5	-	-	-	-	7½	G	
	13-27	7½	H	7½	H	10	H	
2	13-27	-	-	-	-	20	H	
	25-50	10	J	15	J	25	J	
3	17-35	-	-	-	-	-	-	
	35-70	20	L	25	L	50	L	
	65-135	25	M	30	M	-	-	
4	65-135	40	M	50	M	100	M	
						100	M	

Optional ranges

OL amp range	NEMA size		
	0 and 1	2	3 and 4
0.4-0.85	C	-	-
0.8-1.7	D	-	-
1.6-3.4	E	-	-
3.2-6.8	F	-	-
6.5-13.5	G	G	-
13-27	H	H	-
25-50	-	J	-
17-35	-	-	K
35-70	-	-	L
65-135	-	-	M

Enclosed combination magnetic starters

CR407 non-reversing, thermal magnetic circuit breaker

Ordering code configuration

Valid for NEMA sizes 0–4



To configure the ordering code, use the tables below to fill in the digit boxes with the appropriate code.

Step 5 (digit 13) select auxiliary contacts

Aux contacts	Code
None	A
1 NO	B
1 NC	C
1 NO–1 NC	D
2 NO	E
2 NC	F
2 NO–1 NC	G
1 NO–2 NC	H
3 NO	J
3 NC	K
4 NO	L ³
4 NC	M ³
2 NO–2 NC	N ³
3 NO–1 NC	P ³
1 NO–3 NC	R ³

³Exceeds maximum number of contacts for some pilot light selections. See step 8 (digit 16).

Step 6 (digit 14) select monitoring options

Device	Code
None	A
Phase failure relay with undervoltage protection (panel mounted) — 190–480 V (PFR w/UV)	C ²
Phase failure relay with undervoltage protection (panel mounted) — 575 V (PFR w/UV)	D ²
Phase failure relay — 208 V (PFR)	E ^{4,6}
Phase failure relay — 240 V (PFR)	F ^{4,6}
Phase failure relay — 480 V (PFR)	G ^{4,6}
Phase failure relay — 575 V (PFR)	H ^{4,6}
Elapsed time meter (120 V/60 Hz) wired across coil (ETM)	I ^{2,5}
ETM + PFR w/UV (190–480 V)	L ^{2,5,6}
ETM + PFR w/UV (575 V)	N ^{2,5,6}
ETM + PFR (208 V)	p ^{2,4,5,6}
ETM + PFR (240 V)	q ^{2,4,5,6}
ETM + PFR (480 V)	r ^{2,4,5,6}
ETM + PFR (575 V)	s ^{2,4,5,6}

²Requires oversized enclosure for NEMA sizes 0–2. Select proper NEMA size and enclosure type from step 1 (digits 1–7).

⁴Available for type 1 enclosure only.

⁵Requires 120 V control circuit voltage or CPT with 120 V secondary.

⁶Requires oversized enclosure for phase failure relay.

Step 7 (digit 15) select pushbutton/selector switch

Pushbutton Push button/selector switch — heavy duty	Code
None	A
Start/stop pushbutton	J
Hand-off-auto (HOA) selector switch	L
Off-on selector switch	M
HOA selector switch and start pushbutton	S
Keyed HOA selector switch, key removal center pos.	N

Enclosed combination magnetic starters

CR407 non-reversing, thermal magnetic circuit breaker

Ordering code configuration

Valid for NEMA sizes 0–4

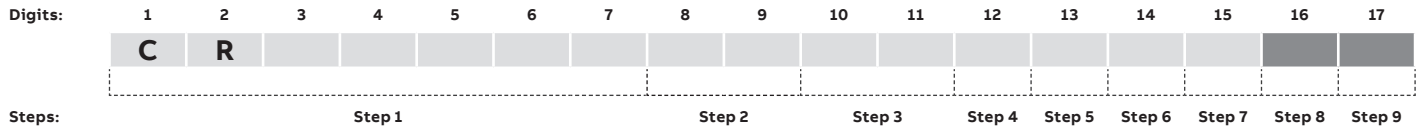

To configure the ordering code, use the tables below to fill in the digit boxes with the appropriate code.

Step 8 (digit 16) select pilot device

Pilot light (heavy duty) type	Color — functionality	Code
None		A
LED lights	Red — across coil	1
	Green — across coil	2
	Red — thru NO aux contact	3 ⁷
	Green — thru NC aux contact	4 ⁷
	Red — thru NO aux contact and green — thru NC aux contact	5 ⁸
	Red — across coil and green — thru NC aux contact	6 ⁷
	Red — across coil and green — thru NC aux contact and unwired amber	7 ⁷
Push-to-test lights	Red — across coil	R
	Green — across coil	S
	Red — thru NO aux contact	C ⁷
	Green — thru NC aux contact	D ⁷
	Red — thru NO aux contact and green — thru NC aux contact	E ⁸
	Red — across coil and green — thru NC aux contact	V ⁷
	Red — across coil and green — thru NC aux contact and unwired amber	Y ⁷

⁷Maximum of 3 Aux contacts may be added to sizes 0 and 1.

⁸Maximum of 2 Aux contacts may be added to sizes 0 and 1. Maximum of 3 Aux contacts may be added to sizes 2–4.

Note: Auxiliary contacts wired as part of pilot light selection are in addition to the auxiliary contacts selected from step 5 (digit 13), which are for customer/field connections.

Step 9 (digit 17) select control options

Device	Code
None	A
1 relay, 2 NO-2 NC, 24/120 V coil — unwired	B ^{2,9}
2 relays, 24/120 V coil — unwired	C ^{2,9}
DIN rail - for customer use	D ²
12 point terminal strip — unwired (12 PT strip)	E ²
Space heater with NC contact	H ^{2,10}
1 relay + 12 PT strip	J ^{2,9}
2 relays + 12 PT strip	K ^{2,9}
DIN rail + 12 PT strip + space heater	L ^{2,10}
2 relays + 12 PT strip + space heater	M ^{2,9,10}
Time delay on relay, 24/120 V coil — unwired (TD)	N ^{2,9}
Time delay off relay, 24/120 V coil — unwired (TD)	P ^{2,9}
12 PT strip + TD on	R ^{2,9}
12 PT strip + TD off	S ^{2,9}
12 PT strip + space heater + TD on	T ^{2,9,10}
12 PT strip + space heater + TD off	U ^{2,9,10}

²Requires oversized enclosure for NEMA sizes 0–2. Select proper NEMA size and enclosure type from step 1 (digits 1–7).

⁹Relay/timer coil voltage is equivalent to CPT secondary voltage. Requires minimum 100 extra VA CPT option.

¹⁰Maximum number of auxiliary contacts shall be reduced by 1.

General note:

On NEMA size 3 and 4 starters, if selecting factory installed and wired operator devices (pushbuttons, selector switches and/or pilot lights), then control circuit fusing, a control power transformer or 120 V separate sourced control is required when the protective device is rated greater than 100 amps.

Enclosed combination magnetic starters

CR308, CR408 non-reversing, non-fusible disconnect switch

NEMA sizes 0–6, nonfusible disconnect type
600 volts maximum 50/60 Hz

Standard features

Includes a holding interlock, pressure terminals for the line and load connections, plus a 3-leg block type ambient compensated overload relay with manual reset. All enclosures include external reset. NO/NC contacts on the overload relay are provided. LED lights standard.

Non-fusible disconnect

Voltage (60 Hz)	NEMA size	Max. hp	Continuous amp rating	NEMA type 1	NEMA type 3R	NEMA type 12	NEMA type 4/4X
				Ordering code	Ordering code	Ordering code	Ordering code
200–208	0	3	18	CR308BT081A4AAAAA	CR408B6081A4AAAAA	CR408B2081A4AAAAA	CR408B4081A4AAAAA
200–208	1	7½	27	CR308CT081A4AAAAA	CR408C6081A4AAAAA	CR408C2081A4AAAAA	CR408C4081A4AAAAA
200–208	2	10	45	CR308DT081A4AAAAA	CR408D6081A4AAAAA	CR408D2081A4AAAAA	CR408D4081A4AAAAA
200–208	3	25	90	CR408E1081A4AAAAA	CR408E6081A4AAAAA	CR408E2081A4AAAAA	CR408E4081A4AAAAA
200–208	4	40	135	CR408F1081A4AAAAA	CR408F6081A4AAAAA	CR408F2081A4AAAAA	CR408F4081A4AAAAA
230–240	0	3	18	CR308BT031A4AAAAA	CR408B6031A4AAAAA	CR408B2031A4AAAAA	CR408B4031A4AAAAA
230–240	1	7½	27	CR308CT031A4AAAAA	CR408C6031A4AAAAA	CR408C2031A4AAAAA	CR408C4031A4AAAAA
230–240	2	15	45	CR308DT031A4AAAAA	CR408D6031A4AAAAA	CR408D2031A4AAAAA	CR408D4031A4AAAAA
230–240	3	30	90	CR408E1031A4AAAAA	CR408E6031A4AAAAA	CR408E2031A4AAAAA	CR408E4031A4AAAAA
230–240	4	50	135	CR408F1031A4AAAAA	CR408F6031A4AAAAA	CR408F2031A4AAAAA	CR408F4031A4AAAAA
460–480	0	5	18	CR308BT041A4AAAAA	CR408B6041A4AAAAA	CR408B2041A4AAAAA	CR408B4041A4AAAAA
460–480	1	10	27	CR308CT041A4AAAAA	CR408C6041A4AAAAA	CR408C2041A4AAAAA	CR408C4041A4AAAAA
460–480	2	25	45	CR308DT041A4AAAAA	CR408D6041A4AAAAA	CR408D2041A4AAAAA	CR408D4041A4AAAAA
460–480	3	50	90	CR408E1041A4AAAAA	CR408E6041A4AAAAA	CR408E2041A4AAAAA	CR408E4041A4AAAAA
460–480	4	100	135	CR408F1041A4AAAAA	CR408F6041A4AAAAA	CR408F2041A4AAAAA	CR408F4041A4AAAAA
575–600	0	5	18	CR308BT051A4AAAAA	CR408B6051A4AAAAA	CR408B2051A4AAAAA	CR408B4051A4AAAAA
575–600	1	10	27	CR308CT051A4AAAAA	CR408C6051A4AAAAA	CR408C2051A4AAAAA	CR408C4051A4AAAAA
575–600	2	25	45	CR308DT051A4AAAAA	CR408D6051A4AAAAA	CR408D2051A4AAAAA	CR408D4051A4AAAAA
575–600	3	50	90	CR408E1051A4AAAAA	CR408E6051A4AAAAA	CR408E2051A4AAAAA	CR408E4051A4AAAAA
575–600	4	100	135	CR408F1051A4AAAAA	CR408F6051A4AAAAA	CR408F2051A4AAAAA	CR408F4051A4AAAAA

- NEMA size 0–4 starters with 115–120 volt, 60 Hz coil for separate control are available. To order, replace digits 8 and 9 of listed ordering codes with 02. Example: CR408C2051A1AAAAA with 115–120 volt, 60 Hz coil for separate control becomes CR408C2021A1AAAAA.
- Motor full load current should not exceed continuous ampere rating of starter.

Please reference the [NEMA full voltage power devices catalog](#) for additional technical data, selection and installation guides, and dimensional drawings.

Enclosed combination magnetic starters

CR308, CR408 non-reversing, fusible disconnect switch

NEMA sizes 0–6, fusible disconnect type
600 volts maximum 50/60 Hz

Standard features

Includes a holding interlock, pressure terminals for the line and load connections, plus a 3-leg block type ambient compensated overload relay with manual reset. All enclosures include external reset. NO/NC contacts on the overload relay are provided. LED lights standard.

Fusible disconnect (class R fuse clips)

Voltage (60 Hz)	NEMA size	Max. hp	Continuous amp rating	Fuse clip amp rating	NEMA type 1	NEMA type 3R	NEMA type 12	NEMA type 4/4X
					Ordering code	Ordering code	Ordering code	Ordering code
200–208	0	3	18	30	CR308BT08RA4AAAAA	CR408B608RA4AAAAA	CR408B208RA4AAAAA	CR408B408RA4AAAAA
200–208	1	5	27	30	CR308CT08RA4AAAAA	CR408C608RA4AAAAA	CR408C208RA4AAAAA	CR408C408RA4AAAAA
200–208	1	7½	27	60	CR308CT08RB4AAAAA	CR408C608RB4AAAAA	CR408C208RB4AAAAA	CR408C408RB4AAAAA
200–208	2	10	45	60	CR308DT08RB4AAAAA	CR408D608RB4AAAAA	CR408D208RB4AAAAA	CR408D408RB4AAAAA
200–208	3	20	90	100	CR408E108RC4AAAAA	CR408E608RC4AAAAA	CR408E208RC4AAAAA	CR408E408RC4AAAAA
200–208	3	25	90	200 ¹	CR408E108RD4AAAAA	CR408E608RD4AAAAA	CR408E208RD4AAAAA	CR408E408RD4AAAAA
200–208	4	40	135	200 ¹	CR408F108RD4AAAAA	CR408F608RD4AAAAA	CR408F208RD4AAAAA	CR408F408RD4AAAAA
230–240	0	3	18	30	CR308BT03RA4AAAAA	CR408B603RA4AAAAA	CR408B203RA4AAAAA	CR408B403RA4AAAAA
230–240	1	5	27	30	CR308CT03RA4AAAAA	CR408C603RA4AAAAA	CR408C203RA4AAAAA	CR408C403RA4AAAAA
230–240	1	7½	27	60	CR308CT03RB4AAAAA	CR408C603RB4AAAAA	CR408C203RB4AAAAA	CR408C403RB4AAAAA
230–240	2	15	45	60	CR308DT03RB4AAAAA	CR408D603RB4AAAAA	CR408D203RB4AAAAA	CR408D403RB4AAAAA
230–240	3	25	90	100	CR408E103RC4AAAAA	CR408E603RC4AAAAA	CR408E203RC4AAAAA	CR408E403RC4AAAAA
230–240	3	30	90	200 ¹	CR408E103RD4AAAAA	CR408E603RD4AAAAA	CR408E203RD4AAAAA	CR408E403RD4AAAAA
230–240	4	50	135	200 ¹	CR408F103RD4AAAAA	CR408F603RD4AAAAA	CR408F203RD4AAAAA	CR408F403RD4AAAAA
460–480	0	5	18	30	CR308BT04R34AAAAA	CR408B604R34AAAAA	CR408B204R34AAAAA	CR408B404R34AAAAA
460–480	1	10	27	30	CR308CT04R34AAAAA	CR408C604R34AAAAA	CR408C204R34AAAAA	CR408C404R34AAAAA
460–480	2	25	45	60	CR308DT04R64AAAAA	CR408D604R64AAAAA	CR408D204R64AAAAA	CR408D404R64AAAAA
460–480	3	50	90	100	CR408E104R14AAAAA	CR408E604R14AAAAA	CR408E204R14AAAAA	CR408E404R14AAAAA
460–480	4	100	135	200 ¹	CR408F104R24AAAAA	CR408F604R24AAAAA	CR408F204R24AAAAA	CR408F404R24AAAAA
575–600	0	5	18	30	CR308BT05R34AAAAA	CR408B605R34AAAAA	CR408B205R34AAAAA	CR408B405R34AAAAA
575–600	1	10	27	30	CR308CT05R34AAAAA	CR408C605R34AAAAA	CR408C205R34AAAAA	CR408C405R34AAAAA
575–600	2	15	45	30	CR308DT05R34AAAAA	CR408D605R34AAAAA	CR408D205R34AAAAA	CR408D405R34AAAAA
575–600	2	25	45	60	CR308DT05R64AAAAA	CR408D605R64AAAAA	CR408D205R64AAAAA	CR408D405R64AAAAA
575–600	3	30	90	60	CR408E105R64AAAAA	CR408E605R64AAAAA	CR408E205R64AAAAA	CR408E405R64AAAAA
575–600	3	50	90	100	CR408E105R14AAAAA	CR408E605R14AAAAA	CR408E205R14AAAAA	CR408E405R14AAAAA
575–600	4	60	135	100 ¹	CR408F105R14AAAAA	CR408F605R14AAAAA	CR408F205R14AAAAA	CR408F405R14AAAAA
575–600	4	100	135	200 ¹	CR408F105R24AAAAA	CR408F605R24AAAAA	CR408F205R24AAAAA	CR408F405R24AAAAA

¹Oversized enclosure provided as standard.

• NEMA size 0–4 starters with 115–120 volt, 60 Hz coil for separate control are available. To order, replace digits 8 and 9 of listed ordering codes with 02.
 Example: CR408D604R61AAAAA with 115–120 volt, 60 Hz coil for separate control becomes CR408D602R61AAAAA.

• For ordinary starting duty only

• Motor full load current should not exceed continuous ampere rating of starter.

• hp rating is based on dual element fuses.

Please reference the [NEMA full voltage power devices catalog](#) for additional technical data, selection and installation guides, and dimensional drawings.

Enclosed combination magnetic starters

CR308 non-reversing, disconnect switch

Ordering code configuration

Valid for NEMA sizes 0–2, type 1 standard enclosure

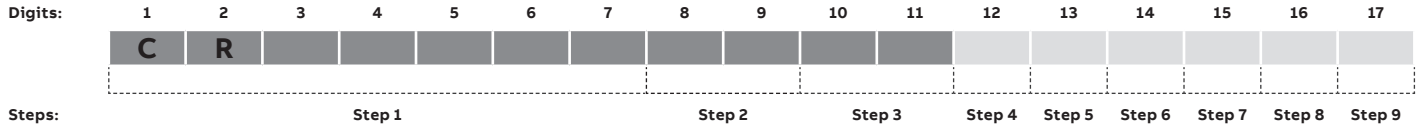

To configure the ordering code, use the tables below to fill in the digit boxes with the appropriate code.

Step 1 (digits 1–7) select NEMA size and enclosure

NEMA size	NEMA type 1 Standard enclosure
0	CR308BT
1	CR308CT
2	CR308DT

Note: All enclosures include external overload reset buttons.

Step 2 (digits 8, 9) select control voltage

Control circuit voltage and CPT	No CPT	Control fuses, no CPT	Standard size CPT
120 V with surge protector (SP)	01	F1	–
120 V	02	F2	–
240 V	03	F3	–
480 V	04	F4	–
600 V	05	F5	–
208 V	08	F8	–
24 V	09	–	–
240 V/120 V with CPT	–	–	93
480 V/120 V with CPT	–	–	94
600 V/120 V with CPT	–	–	95
208 V/120 V with CPT	–	–	98
240 V/120 V with CPT and SP	–	–	33
480 V/120 V with CPT and SP	–	–	34
600 V/120 V with CPT and SP	–	–	35
208 V/120 V with CPT and SP	–	–	38
240 V/24 V with CPT	–	–	53
480 V/24 V with CPT	–	–	54
600 V/24 V with CPT	–	–	55
208 V/24 V with CPT	–	–	58

Note: CPT includes 2 primary fuses and 1 secondary fuse.

Step 3 (digits 10, 11) select protective device

NEMA size	Code
All	1A

Note: All enclosures include external overload reset buttons.

Disconnect with class H fuse clips — for use with non-time delay/single element class H fuses

NEMA size	200–208 V			230–240 V			460–480 V			575–600 V		
	Max. hp	Fuse clip (amps)	Code	Max. hp	Fuse clip (amps)	Code	Max. hp	Fuse clip (amps)	Code	Max. hp	Fuse clip (amps)	Code
0	3	30	HA	3	30	HA	5	30	H3	5	30	H3
1	7½	60	HB	7½	60	HB	7½	30	H3	10	30	H3
	–	–	–	–	–	–	10	60	H6	–	60	H6
2	10	100	HC	15	100	HC	15	60	H6	20	60	H6
	–	–	–	–	–	–	25	100	H1 ¹	25	100	H1 ¹

¹Oversized enclosure included as standard.

Enclosed combination magnetic starters

CR308 non-reversing, disconnect switch

Ordering code configuration

Valid for NEMA sizes 0–2, type 1 standard enclosure

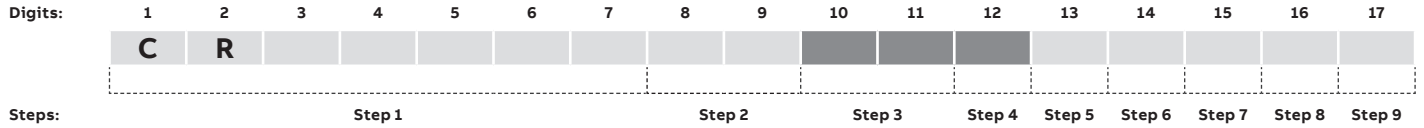

To configure the ordering code, use the tables below to fill in the digit boxes with the appropriate code.

Step 3 (digits 10, 11) select protective device (continued)

Disconnect with class R fuse clips — for use with time delay/dual element class RK1/RK5 fuses

NEMA size	200–208 V			230–240 V			460–480 V			575–600 V		
	Max. hp	Fuse clip (amps)	Code	Max. hp	Fuse clip (amps)	Code	Max. hp	Fuse clip (amps)	Code	Max. hp	Fuse clip (amps)	Code
0	3	30	RA	3	30	RA	5	30	R3	5	30	R3
1	5	30	RA	5	30	RA	10	30	R3	10	30	R3
	7½	60	RB	7½	60	RB	–	–	–	–	–	–
2	10	60	RB	15	60	RB	–	30	R3	15	30	R3
	–	–	–	–	–	–	25	60	R6	25	60	R6

Disconnect with class J fuse clips — for use with time delay/dual element class J fuses

NEMA size	200–208 V			230–240 V			460–480 V			575–600 V		
	Max. hp	Fuse clip (amps)	Code	Max. hp	Fuse clip (amps)	Code	Max. hp	Fuse clip (amps)	Code	Max. hp	Fuse clip (amps)	Code
0	3	30	J3	3	30	J3	5	30	J3	5	30	J3
1	5	30	J3	5	30	J3	10	30	J3	10	30	J3
	7½	60	J6	7½	60	J6	–	–	–	–	–	–
2	10	60	J6	15	60	J6	–	30	J3	15	30	J3
	–	–	–	–	–	–	25	60	J6	25	60	J6

Step 4 (digit 12) select overload relay

Overload relay	Code
Thermal bi-metallic ambient compensated (1 NC)	3
Thermal bi-metallic ambient compensated (1 NO–1 NC)	4
Solid state overload (1 NO–1 NC)	(#)

(#) Select code for solid state overload amp rating from standard or optional ranges table below.

Solid state overload relay — standard range

NEMA size	200–208 V		230–240 V		460–480 V		575–600 V	
	OL range	Code	OL range	Code	OL range	Code	OL range	Code
0	0.8–1.7	–	–	–	¾	D	1	D
	1.6–3.4	½	¾	E	2	E	2	E
	3.2–6.8	1	2	F	3	F	5	F
1	6.5–13.5	3	3	G	5	G	–	–
	6.5–13.5	–	–	–	7½	G	10	G
2	13–27	7½	7½	H	10	H	–	–
	13–27	–	–	–	20	H	25	H
	25–50	10	15	J	25	J	–	–

Optional ranges

OL amp range	NEMA size	
	0 and 1	2
0.4–0.85	C	–
0.8–1.7	D	–
1.6–3.4	E	–
3.2–6.8	F	–
6.5–13.5	G	G
13–27	H	H
25–50	–	J
17–35	–	–
35–70	–	–
65–135	–	–

Please reference the [NEMA full voltage power devices catalog](#) for additional technical data, selection and installation guides, and dimensional drawings.

Enclosed combination magnetic starters

CR308 non-reversing, disconnect switch

Ordering code configuration

Valid for NEMA sizes 0–2, type 1 standard enclosure

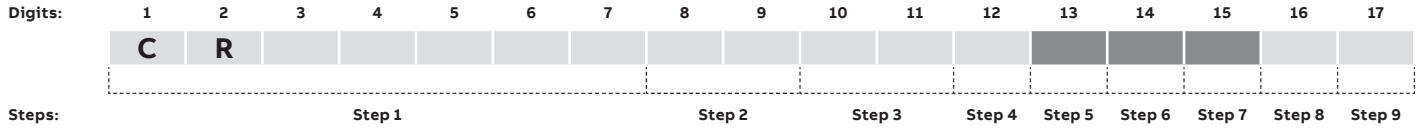

To configure the ordering code, use the tables below to fill in the digit boxes with the appropriate code.

Step 5 (digit 13) select auxiliary contacts

Auxiliary contacts	Code
None	A
1 NO	B
1 NC	C
1 NO–1 NC	D
2 NO	E
2 NC	F
2 NO–1 NC	G
1 NO–2 NC	H

Step 5 (digit 13) select auxiliary contacts (continued)

Auxiliary contacts	Code
3 NO	J
3 NC	K
4 NO	L ²
4 NC	M ²
2 NO–2 NC	N ²
3 NO–1 NC	P ²
1 NO–3 NC	R ²

²Exceeds maximum number of contacts for some pilot light selections. See step 8 (digit 16).

Step 6 (digit 14) select monitoring options

Device	Code
None ³	A

³Phase failure relay is not available for CR308 series standard enclosures. If this is required for your application, use CR408 series oversized enclosure.

Step 7 (digit 15) select pushbutton/selector switch

Pushbutton/selector switch — heavy duty	Code
None	A
Start/stop pushbutton	J
Hand-off-auto (HOA) selector switch	L
Off-on selector switch	M
HOA selector switch and start pushbutton	S
Keyed HOA selector switch, key removal center pos.	N

Please reference the [NEMA full voltage power devices catalog](#) for additional technical data, selection and installation guides, and dimensional drawings.

Enclosed combination magnetic starters

CR308 non-reversing, disconnect switch

Ordering code configuration

Valid for NEMA sizes 0–2, type 1 standard enclosure

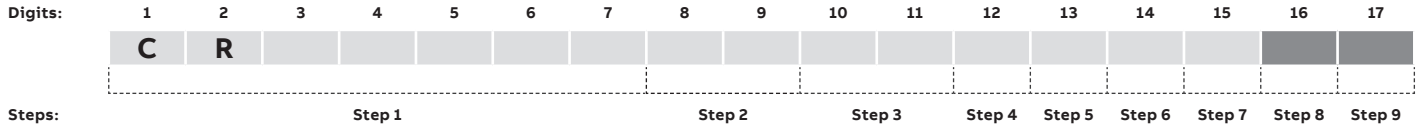

To configure the ordering code, use the tables below to fill in the digit boxes with the appropriate code.

Step 8 (digit 16) select pilot device

Type	Color - functionality	Code
None		A
LED lights	Red — across coil	1
	Green — across coil	2
	Red — thru NO aux contact	3 ⁴
	Green — thru NC aux contact	4 ⁴
	Red — thru NO aux contact and green — thru NC aux contact	5 ⁵
	Red — across coil and green — thru NC aux contact	6 ⁴
	Red — across coil and green — thru NC aux contact and unwired amber	7 ⁴
Push-to-test lights	Red — across coil	R
	Green — across coil	S
	Red — thru NO aux contact	C ⁴
	Green — thru NC aux contact	D ⁴
	Red — thru NO aux contact and green — thru NC aux contact	E ⁵
	Red — across coil and green — thru NC aux contact	V ⁴
	Red — across coil and green — thru NC aux contact and unwired amber	Y ⁴

⁴Maximum of 3 aux contacts may be added to Sizes 0 and 1.

⁵Maximum of 2 aux contacts may be added to Sizes 0 and 1. Maximum of 3 aux contacts may be added to sizes 2–4.

Note: Auxiliary contacts wired as part of pilot light selection are in addition to the auxiliary contacts selected from step 5 (digit 13), which are for customer/field connections.

Step 9 (digit 17) select control options

Device	Code
None	A

General note:

On NEMA size 3 and 4 starters, if selecting factory installed and wired operator devices (pushbuttons, selector switches and/or pilot lights), then control circuit fusing, a control power transformer or 120 V separate sourced control is required when the protective device is rated greater than 100 amps.

Please reference the [NEMA full voltage power devices catalog](#) for additional technical data, selection and installation guides, and dimensional drawings.

Enclosed combination magnetic starters

CR408 non-reversing, disconnect switch

Ordering code configuration

Valid for NEMA sizes 0–4

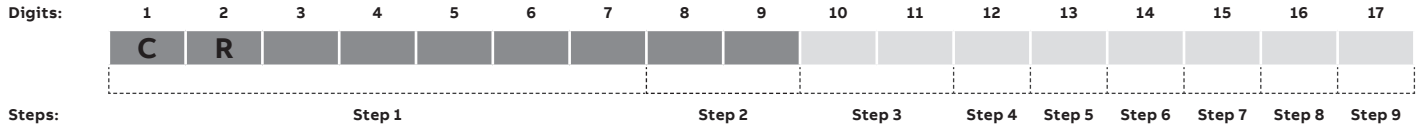

To configure the ordering code, use the tables below to fill in the digit boxes with the appropriate code.

Step 1 (digits 1–7) select NEMA size and enclosure

NEMA size	NEMA type 1		NEMA type 3R		NEMA type 12		NEMA type 4/4X	
	Standard enclosure	Oversized enclosure	Standard enclosure	Oversized enclosure	Standard enclosure	Oversized enclosure	Standard enclosure	Oversized enclosure
0	Use CR308	CR408B5	CR408B6	CR408BR	CR408B2	CR408B7	CR408B4	CR408B5
1	Use CR308	CR408C5	CR408C6	CR408CR	CR408C2	CR408C7	CR408C4	CR408CS
2	Use CR308	CR408D5	CR408D6	CR408DR	CR408D2	CR408D7	CR408D4	CR408DS
3	CR408E1	CR408E5 ¹	CR408E6	CR408ER ¹	CR408E2	CR408E7 ¹	CR408E4	CR408ES ¹
4 ²	CR408F1	–	CR408F6	–	CR408F2	–	CR408F4	–

Note: All enclosures include external overload reset buttons. NEMA 4 enclosures are stainless steel.

¹Oversized enclosure provided as standard with 200 amp fusible disconnect.

²Oversized enclosure provided as standard with any NEMA size 4 fusible/non-fusible.

Step 2 (digits 8, 9) select control voltage (no CPT and standard size CPT)

Control circuit voltage and CPT	No CPT	Control fuses, no CPT	Standard size CPT
120 V with surge protector (SP)	01	F1	–
120 V	02	F2	–
240 V	03	F3	–
480 V	04	F4	–
600 V	05	F5	–
208 V	08	F8	–
24 V ³	09	–	–
240 V/120 V with CPT	–	–	93
480 V/120 V with CPT	–	–	94
600 V/120 V with CPT	–	–	95
208 V/120 V with CPT	–	–	98
240 V/120 V with CPT and SP	–	–	33
480 V/120 V with CPT and SP	–	–	34
600 V/120 V with CPT and SP	–	–	35
208 V/120 V with CPT and SP	–	–	38
240 V/24 V with CPT ³	–	–	53
480 V/24 V with CPT ³	–	–	54
600 V/24 V with CPT ³	–	–	55
208 V/24 V with CPT ³	–	–	58

Note: CPT includes 2 primary fuses and 1 secondary fuse.

³24 V coils are not available for NEMA size 3 and above.

Please reference the [NEMA full voltage power devices catalog](#) for additional technical data, selection and installation guides, and dimensional drawings.

Enclosed combination magnetic starters

CR408 non-reversing, disconnect switch

Ordering code configuration

Valid for NEMA sizes 0-4

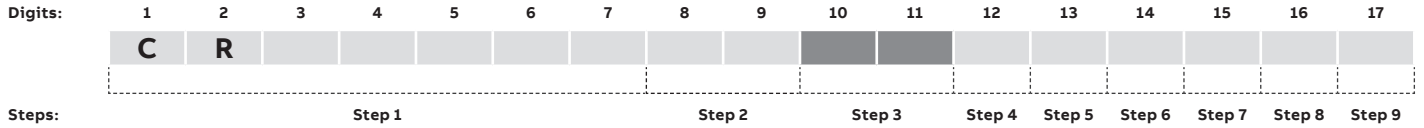

To configure the ordering code, use the tables below to fill in the digit boxes with the appropriate code.

Step 3 (digits 10, 11) select protective device

Disconnect without fuse clips

NEMA size	Code
All	1A ²

Disconnect with class H fuse clips — for use with non-time delay/single element class H fuses

NEMA size	200-208 V			230-240 V			460-480 V			575-600 V		
	Max. hp	Fuse clip (amps)	Code	Max. hp	Fuse clip (amps)	Code	Max. hp	Fuse clip (amps)	Code	Max. hp	Fuse clip (amps)	Code
0	3	30	HA	3	30	HA	5	30	H3	5	30	H3
1	7½	60	HB	7½	60	HB	7½	30	H3	10	30	H3
	-	-	-	-	-	-	10	60	H6	-	60	H6
2	10	100	HC	15	100	HC	15	60	H6	20	60	H6
	-	-	-	-	-	-	25	100	H1	25	100	H1
3 ¹	25	200	HD	30	200	HD	30	100	H1	30	100	H1
	-	-	-	-	-	-	50	200	H2	50	200	H2
4 ²	40	400	HE	50	400	HE	60	200	H2	60	200	H2
	-	-	-	-	-	-	100	400	H4	100	400	H4

¹Oversized enclosure provided as standard with 200 amp fusible disconnect
²Oversized enclosure provided as standard with any NEMA size 4 fusible/non-fusible

Disconnect with class R fuse clips — for use with time delay/dual element class RK1/RK5 fuses

NEMA size	200-208 V			230-240 V			460-480 V			575-600 V		
	Max. hp	Fuse clip (amps)	Code	Max. hp	Fuse clip (amps)	Code	Max. hp	Fuse clip (amps)	Code	Max. hp	Fuse clip (amps)	Code
0	3	30	RA	3	30	RA	5	30	R3	5	30	R3
1	5	30	RA	5	30	RA	10	30	R3	10	30	R3
	7½	60	RB	7½	60	RB	-	-	-	-	-	-
2	10	60	RB	15	60	RB	-	30	R3	15	30	R3
	-	-	-	-	-	-	25	60	R6	25	60	R6
3 ¹	20	100	RC	25	100	RC	-	60	R6	30	60	R6
	25	200	RD	30	200	RD	50	100	R1	50	100	R1
4 ²	40	200	RD	50	200	RD	-	100	R1	60	100	R1
	-	-	-	-	-	-	100	200	R2	100	200	R2

¹Oversized enclosure provided as standard with 200 amp fusible disconnect
²Oversized enclosure provided as standard with any NEMA size 4 fusible/non-fusible

Please reference the [NEMA full voltage power devices catalog](#) for additional technical data, selection and installation guides, and dimensional drawings.

Enclosed combination magnetic starters

CR408 non-reversing, disconnect switch

Ordering code configuration

Valid for NEMA sizes 0-4

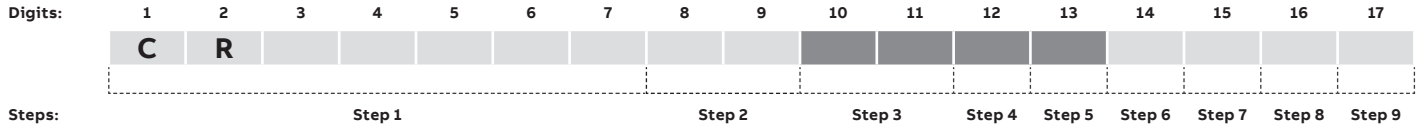

To configure the ordering code, use the tables below to fill in the digit boxes with the appropriate code.

Step 3 (digits 10, 11) select protective device (continued)

Disconnect with class J fuse clips — for use with time delay/dual element class J fuses

NEMA size	200-208 V			230-240 V			460-480 V			575-600 V		
	Max. hp	Fuse clip (amps)	Code	Max. hp	Fuse clip (amps)	Code	Max. hp	Fuse clip (amps)	Code	Max. hp	Fuse clip (amps)	Code
0	3	30	J3	3	30	J3	5	30	J3	5	30	J3
1	5	30	J3	5	30	J3	10	30	J3	10	30	J3
2	7½	60	J6	7½	60	J6	-	-	-	-	-	-
	10	60	J6	15	60	J6	-	30	J3	15	30	J3
3 ¹	-	-	-	-	-	-	25	60	J6	25	60	J6
	20	100	J2	25	100	J1	-	60	J6	30	60	J6
4 ²	25	200	J2	30	200	J2	50	100	J1	50	100	J1
	40	200	J2	50	200	J2	-	100	J1	60	100	J1
	-	-	-	-	-	-	100	200	J2	100	200	J2

¹Oversized enclosure provided as standard with 200 amp fusible disconnect
²Oversized enclosure provided as standard with any NEMA size 4 fusible/non-fusible

Step 4 (digit 12) select overload relay

Overload relay	Code
Thermal bi-metallic ambient compensated (1 NC)	3
Thermal bi-metallic ambient compensated (1 NO-1 NC)	4
Solid state overload (1 NO-1 NC)	(#)

(#) Select code for solid state overload amp rating from standard or optional ranges table at right and below.

Solid state overload relay — standard range

NEMA size	200-208 V		230-240 V		460-480 V		575-600 V	
	OL range	Max. hp Code	Max. hp Code	Max. hp Code	Max. hp Code			
0	0.8-1.7	- -	- -	¾	D 1 D			
	1.6-3.4	1/2 E	3/4 E	2 E	2 E			
	3.2-6.8	1 F	2 F	3 F	5 F			
1	6.5-13.5	3 G	3 G	5 G	- -			
	6.5-13.5	- -	- -	7½ G	10 G			
2	13-27	7½ H	7½ H	10 H	- -			
	13-27	- -	- -	20 H	25 H			
3	25-50	10 J	15 J	25 J	- -			
	17-35	- -	- -	- -	30 K			
4	35-70	20 L	25 L	50 L	50 L			
	65-135	25 M	30 M	- -	- -			
	65-135	40 M	50 M	100 M	100 M			

Solid state overload relay — optional ranges

OL amp range	NEMA size		
	0 and 1	2	3 and 4
0.4-0.85	C	-	-
0.8-1.7	D	-	-
1.6-3.4	E	-	-
3.2-6.8	F	-	-
6.5-13.5	G	G	-
13-27	H	H	-
25-50	-	J	-
17-35	-	-	K
35-70	-	-	L
65-135	-	-	M

Step 5 (digit 13) select auxiliary contacts

Auxiliary contacts	Code
None	A
1 NO	B
1 NC	C
1 NO-1 NC	D
2 NO	E
2 NC	F
2 NO-1 NC	G
1 NO-2 NC	H

Step 5 (digit 13) select auxiliary contacts (continued)

Auxiliary contacts	Code
3 NO	J
3 NC	K
4 NO	L ⁵
4 NC	M ⁵
2 NO-2 NC	N ⁵
3 NO-1 NC	P ⁵
1 NO-3 NC	R ⁵

⁵Exceeds maximum number of contacts for some pilot light selections. See step 8 (digit 16).

Enclosed combination magnetic starters

CR408 non-reversing, disconnect switch

Ordering code configuration

Valid for NEMA sizes 0-4

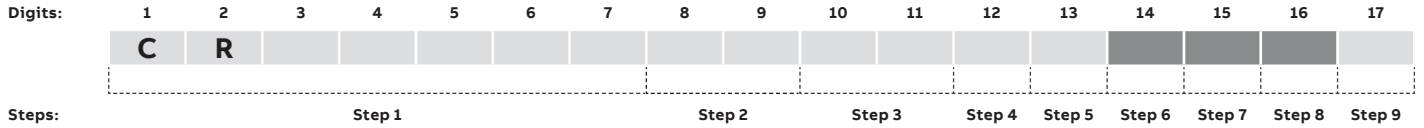

To configure the ordering code, use the tables below to fill in the digit boxes with the appropriate code.

Step 6 (digit 14) select monitoring options

Device	Code
None	A
Phase failure relay with undervoltage protection (panel mounted) — 190-480 V (PFR with UV)	C ^{2,7}
Phase failure relay with undervoltage protection (panel mounted) — 575 V (PFR with UV)	D ^{2,7}
Phase failure relay — 208 V (PFR)	E ^{4,7}
Phase failure relay — 240 V (PFR)	F ^{4,7}
Phase failure relay — 480 V (PFR)	G ^{4,7}
Phase failure relay — 575 V (PFR)	H ^{4,7}
Elapsed time meter (120 V/60 Hz) wired across coil (ETM)	I ^{2,6}
ETM + PFR w/UV (190-480 V)	L ^{2,6,7}
ETM + PFR w/UV (575 V)	N ^{2,6,7}
ETM + PFR (208 V)	P ^{2,4,6,7}
ETM + PFR (240 V)	Q ^{2,4,6,7}
ETM + PFR (480 V)	R ^{2,4,6,7}
ETM + PFR (575 V)	S ^{2,4,6,7}

²Requires oversized enclosure for NEMA sizes 0-2. Select proper NEMA size and enclosure type from step 1 (digits 1-7).

⁴Available for type 1 enclosure only.

⁶Requires 120 V control circuit voltage or CPT with 120 V secondary.

⁷Requires oversized enclosure for phase failure relay.

Step 7 (digit 15) select pushbutton/selector switch

Pushbutton/selector switch — heavy duty	code
None	A
Start/stop pushbutton	J
Hand-off-auto (HOA) selector switch	L
Off-on selector switch	M
HOA selector switch and start pushbutton	S
Keyed HOA selector switch, key removal center pos.	N

Step 8 (digit 16) select pilot device

Type	Color - functionality	Code
None		A
LED lights	Red — across coil	1
	Green — across coil	2
	Red — thru NO aux contact	3 ⁹
	Green — thru NC aux contact	4 ⁹
	Red — thru NO aux contact and green — thru NC aux contact	5 ¹⁰
	Red — across coil and green — thru NC aux contact	6 ⁹
Push-to-test lights	Red — across coil and green — thru NC aux contact and unwired amber	7 ⁹
	Red — across coil	R
	Green — across coil	S
	Red — thru NO aux contact	C ⁹
	Green — thru NC aux contact	D ⁹
	Red — thru NO aux contact and green — thru NC aux contact	E ¹⁰
	Red — across coil and green — thru NC aux contact	V ⁹
	Red — across coil and green — thru NC aux contact and unwired amber	Y ⁹

⁹Maximum of 3 aux contacts may be added to sizes 0 and 1.

¹⁰Maximum of 2 aux contacts may be added to sizes 0 and 1. Maximum of 3 aux contacts may be added to sizes 2-4.

Note: Auxiliary contacts wired as part of pilot light selection are in addition to the auxiliary contacts selected from step 5 (digit 13), which are for customer/field connections.

Enclosed combination magnetic starters

CR408 non-reversing, disconnect switch

Ordering code configuration

Valid for NEMA sizes 0–4



To configure the ordering code, use the tables below to fill in the digit boxes with the appropriate code.

9 (digit 17) select control options

Device	Code
None	A
DIN rail — for customer use	D ⁴
12 point terminal strip — unwired (12 PT strip)	E ⁴
Space heater with NC contact	H ^{4,12}
DIN rail + 12 PT strip + space heater	L ^{4,12}

⁴Requires oversized enclosure for NEMA sizes 0–2. Select proper NEMA size and enclosure type from step 1 (digits 1–7).

¹²Maximum number of auxiliary contacts shall be reduced by 1.

General note:

On NEMA size 3 and 4 starters, if selecting factory installed and wired operator devices (pushbuttons, selector switches and/or pilot lights), then control circuit fusing, a control power transformer or 120 V separate sourced control is required when the protective device is rated greater than 100 amps.

Please reference the [NEMA full voltage power devices catalog](#) for additional technical data, selection and installation guides, and dimensional drawings.

Enclosed combination magnetic starters

CR387, CR487 non-reversing, instantaneous trip circuit breaker

400 horsepower maximum
NEMA sizes 0–6
600 volts maximum
50/60 Hz

The CR387/487 non-reversing starters are designed for more accurate fault protection for motor circuits by utilizing Tmax® XT motor circuit protectors.

Features

- Mechanism — always controls interrupting switch.
- Easy inspection, maintenance — performed from starter front.
- LED lights standard.
- Optional factory-installed control transformer.



CR387

Please reference the [NEMA full voltage power devices catalog](#) for additional technical data, selection and installation guides, and dimensional drawings.

Enclosed combination magnetic starters

CR387, CR487 non-reversing, instantaneous trip circuit breaker

200 horsepower maximum
NEMA sizes 0–5, instantaneous trip circuit breaker type
600 volts maximum 50/60 Hz

Standard features

Tmax® XT circuit breaker. Includes a holding interlock, pressure terminals for the line and load connections, plus a 3-leg block type ambient compensated overload relay with manual reset. All enclosures include external reset. NO/NC contacts on the overload relay are provided. LED lights standard.

Instantaneous trip circuit breaker type

Voltage (60 Hz)	NEMA size	Max. hp	Continuous amp rating	CB rating (amps)	NEMA type 1	NEMA type 3R	NEMA type 12	NEMA type 4/4X
					Ordering code	Ordering code	Ordering code	Ordering code
200–208	0	1	18	7	CR387BT08MB4AAAAA	CR487B608MB4AAAAA	CR487B208MB4AAAAA	CR487B408MB4AAAAA
200–208	0	3	18	15	CR387BT08MC4AAAAA	CR487B608MC4AAAAA	CR487B208MC4AAAAA	CR487B408MC4AAAAA
200–208	1	5	27	25	CR387CT08ME4AAAAA	CR487C608ME4AAAAA	CR487C208ME4AAAAA	CR487C408ME4AAAAA
200–208	1	7½	27	40	CR387CT08MG4AAAAA	CR487C608MG4AAAAA	CR487C208MG4AAAAA	CR487C408MG4AAAAA
200–208	2	10	45	50	CR387DT08MH4AAAAA	CR487D608MH4AAAAA	CR487D208MH4AAAAA	CR487D408MH4AAAAA
200–208	3	15	90	70	CR487E108MK4AAAAA	CR487E608MK4AAAAA	CR487E208MK4AAAAA	CR487E408MK4AAAAA
200–208	3	20	90	80	CR487E108ML4AAAAA	CR487E608ML4AAAAA	CR487E208ML4AAAAA	CR487E408ML4AAAAA
200–208	3	25	90	100	CR487E108MN4AAAAA	CR487E608MN4AAAAA	CR487E208MN4AAAAA	CR487E408MN4AAAAA
200–208	4	30	135	125	CR487F108MQ4AAAAA	CR487F608MQ4AAAAA	CR487F208MQ4AAAAA	CR487F408MQ4AAAAA
200–208	4	40	135	150	CR487F108MR4AAAAA	CR487F608MR4AAAAA	CR487F208MR4AAAAA	CR487F408MR4AAAAA
230–240	0	½	18	3	CR387BT03MA4AAAAA	CR487B603MA4AAAAA	CR487B203MA4AAAAA	CR487B403MA4AAAAA
230–240	0	1	18	7	CR387BT03MB4AAAAA	CR487B603MB4AAAAA	CR487B203MB4AAAAA	CR487B403MB4AAAAA
230–240	0	3	18	15	CR387BT03MC4AAAAA	CR487B603MC4AAAAA	CR487B203MC4AAAAA	CR487B403MC4AAAAA
230–240	1	5	27	25	CR387CT03ME4AAAAA	CR487C603ME4AAAAA	CR487C203ME4AAAAA	CR487C403ME4AAAAA
230–240	1	7½	27	30	CR387CT03MF4AAAAA	CR487C603MF4AAAAA	CR487C203MF4AAAAA	CR487C403MF4AAAAA
230–240	2	10	45	40	CR387DT03MG4AAAAA	CR487D603MG4AAAAA	CR487D203MG4AAAAA	CR487D403MG4AAAAA
230–240	2	15	45	60	CR387DT03MJ4AAAAA	CR487D603MJ4AAAAA	CR487D203MJ4AAAAA	CR487D403MJ4AAAAA
230–240	3	20	90	70	CR487E103MK4AAAAA	CR487E603MK4AAAAA	CR487E203MK4AAAAA	CR487E403MK4AAAAA
230–240	3	25	90	90	CR487E103MM4AAAAA	CR487E603MM4AAAAA	CR487E203MM4AAAAA	CR487E403MM4AAAAA
230–240	3	30	90	100	CR487E103MN4AAAAA	CR487E603MN4AAAAA	CR487E203MN4AAAAA	CR487E403MN4AAAAA
230–240	4	40	135	150	CR487F103MR4AAAAA	CR487F603MR4AAAAA	CR487F203MR4AAAAA	CR487F403MR4AAAAA
230–240	4	50	135	175	CR487F103MS4AAAAA	CR487F603MS4AAAAA	CR487F203MS4AAAAA	CR487F403MS4AAAAA
460–480	0	1	18	3	CR387BT04MA4AAAAA	CR487B604MA4AAAAA	CR487B204MA4AAAAA	CR487B404MA4AAAAA
460–480	0	3	18	7	CR387BT04MB4AAAAA	CR487B604MB4AAAAA	CR487B204MB4AAAAA	CR487B404MB4AAAAA
460–480	0	5	18	15	CR387BT04MC4AAAAA	CR487B604MC4AAAAA	CR487B204MC4AAAAA	CR487B404MC4AAAAA
460–480	1	7½	27	15	CR387CT04MC4AAAAA	CR487C604MC4AAAAA	CR487C204MC4AAAAA	CR487C404MC4AAAAA
460–480	1	10	27	20	CR387CT04MD4AAAAA	CR487C604MD4AAAAA	CR487C204MD4AAAAA	CR487C404MD4AAAAA
460–480	2	15	45	30	CR387DT04MF4AAAAA	CR487D604MF4AAAAA	CR487D204MF4AAAAA	CR487D404MF4AAAAA
460–480	2	20	45	40	CR387DT04MG4AAAAA	CR487D604MG4AAAAA	CR487D204MG4AAAAA	CR487D404MG4AAAAA
460–480	2	25	45	50	CR387DT04MH4AAAAA	CR487D604MH4AAAAA	CR487D204MH4AAAAA	CR487D404MH4AAAAA
460–480	3	30	90	50	CR487E104MH4AAAAA	CR487E604MH4AAAAA	CR487E204MH4AAAAA	CR487E404MH4AAAAA
460–480	3	40	90	70	CR487E104MK4AAAAA	CR487E604MK4AAAAA	CR487E204MK4AAAAA	CR487E404MK4AAAAA
460–480	3	50	90	90	CR487E104MM4AAAAA	CR487E604MM4AAAAA	CR487E204MM4AAAAA	CR487E404MM4AAAAA
460–480	4	60	135	100	CR487F104MN4AAAAA	CR487F604MN4AAAAA	CR487F204MN4AAAAA	CR487F404MN4AAAAA
460–480	4	75	135	125	CR487F104MQ4AAAAA	CR487F604MQ4AAAAA	CR487F204MQ4AAAAA	CR487F404MQ4AAAAA
460–480	4	100	135	175	CR487F104MS4AAAAA	CR487F604MS4AAAAA	CR487F204MS4AAAAA	CR487F404MS4AAAAA
575–600	0	1	18	3	CR387BT05MA4AAAAA	CR487B605MA4AAAAA	CR487B205MA4AAAAA	CR487B405MA4AAAAA
575–600	0	3	18	7	CR387BT05MB4AAAAA	CR487B605MB4AAAAA	CR487B205MB4AAAAA	CR487B405MB4AAAAA
575–600	0	5	18	15	CR387BT05MC4AAAAA	CR487B605MC4AAAAA	CR487B205MC4AAAAA	CR487B405MC4AAAAA

* Motor full load current should not exceed continuous ampere rating of starter.

Please reference the [NEMA full voltage power devices catalog](#) for additional technical data, selection and installation guides, and dimensional drawings.

Enclosed combination magnetic starters

CR387, CR487 non-reversing, instantaneous trip circuit breaker

200 horsepower maximum

NEMA sizes 0–5, instantaneous trip circuit breaker type

600 volts maximum 50/60 Hz

Standard features

Tmax® XT circuit breaker. Includes a holding interlock, pressure terminals for the line and load connections, plus a 3-leg block type ambient compensated overload relay with manual reset. All enclosures include external reset. NO/NC contacts on the overload relay are provided. LED lights standard.

Instantaneous trip circuit breaker type (continued)

Voltage (60 Hz)	NEMA size	Max. hp	Continuous amp rating	CB rating (amps)	NEMA type 1	NEMA type 3R	NEMA type 12	NEMA type 4/4X
					Ordering code	Ordering code	Ordering code	Ordering code
575–600	1	10	27	15	CR387CT05MC4AAAAA	CR487C605MC4AAAAA	CR487C205MC4AAAAA	CR487C405MC4AAAAA
575–600	2	15	45	25	CR387DT05ME4AAAAA	CR487D605ME4AAAAA	CR487D205ME4AAAAA	CR487D405ME4AAAAA
575–600	2	20	45	30	CR387DT05MF4AAAAA	CR487D605MF4AAAAA	CR487D205MF4AAAAA	CR487D405MF4AAAAA
575–600	2	25	45	40	CR387DT05MG4AAAAA	CR487D605MG4AAAAA	CR487D205MG4AAAAA	CR487D405MG4AAAAA
575–600	3	30	90	40	CR487E105MG4AAAAA	CR487E605MG4AAAAA	CR487E205MG4AAAAA	CR487E405MG4AAAAA
575–600	3	40	90	60	CR487E105MJ4AAAAA	CR487E605MJ4AAAAA	CR487E205MJ4AAAAA	CR487E405MJ4AAAAA
575–600	3	50	90	70	CR487E105MK4AAAAA	CR487E605MK4AAAAA	CR487E205MK4AAAAA	CR487E405MK4AAAAA
575–600	4	60	135	80	CR487F105ML4AAAAA	CR487F605ML4AAAAA	CR487F205ML4AAAAA	CR487F405ML4AAAAA
575–600	4	75	135	100	CR487F105MN4AAAAA	CR487F605MN4AAAAA	CR487F205MN4AAAAA	CR487F405MN4AAAAA
575–600	4	100	135	150	CR487F105MR4AAAAA	CR487F605MR4AAAAA	CR487F205MR4AAAAA	CR487F405MR4AAAAA

* Motor full load current should not exceed continuous ampere rating of starter.

Please reference the [NEMA full voltage power devices catalog](#) for additional technical data, selection and installation guides, and dimensional drawings.

Enclosed combination magnetic starters

CR387 non-reversing, instantaneous trip circuit breaker

Ordering code configuration

Valid for NEMA sizes 0–2, type 1 standard enclosure

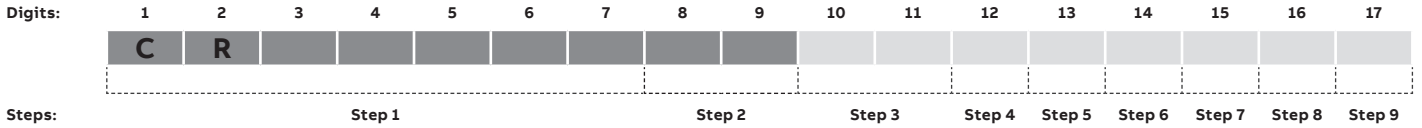

To configure the ordering code, use the tables below to fill in the digit boxes with the appropriate code.

Step 1 (digits 1–7) select NEMA size and enclosure

NEMA size	NEMA type 1	
	Standard enclosure	
0	CR387BT	
1	CR387CT	
2	CR387DT	

Note: All enclosures include external overload reset buttons.

Step 2 (digits 8, 9) select control voltage

Control circuit voltage and CPT	Control fuses,			Standard size CPT	Standard size CPT + 100 VA
	No CPT	no CPT			
120 V with surge protector (SP)	01	F1	-	-	-
120 V	02	F2	-	-	-
240 V	03	F3	-	-	-
480 V	04	F4	-	-	-
600 V	05	F5	-	-	-
208 V	08	F8	-	-	-
24 V	09	-	-	-	-
240 V/120 V with CPT	-	-	93	13	-
480 V/120 V with CPT	-	-	94	14	-
600 V/120 V with CPT	-	-	95	15	-
208 V/120 V with CPT	-	-	98	18	-
240 V/120 V with CPT and SP	-	-	33	53	-
480 V/120 V with CPT and SP	-	-	34	54	-
600 V/120 V with CPT and SP	-	-	35	55	-
208 V/120 V with CPT and SP	-	-	38	58	-
240 V/24 V with CPT	-	-	S3	A3	-
480 V/24 V with CPT	-	-	S4	A4	-
600 V/24 V with CPT	-	-	S5	A5	-
208 V/24 V with CPT	-	-	S8	A8	-

Note: CPT includes 2 primary fuses and 1 secondary fuse.

Please reference the [NEMA full voltage power devices catalog](#) for additional technical data, selection and installation guides, and dimensional drawings.

Enclosed combination magnetic starters

CR387 non-reversing, instantaneous trip circuit breaker

Ordering code configuration

Valid for NEMA sizes 0–2, type 1 standard enclosure



To configure the ordering code, use the tables below to fill in the digit boxes with the appropriate code.

Step 3 (digits 10, 11) select protective device

Instantaneous trip circuit breaker

NEMA size	208 V			240 V			480 V			600 V		
	Max. hp	CB rating (amps)	Code	Max. hp	CB rating (amps)	Code	Max. hp	CB rating (amps)	Code	Max. hp	CB rating (amps)	Code
0	0.5	3	MA	0.5	3	MA	1	3	MA	1	3	MA
	1	7	MB	-	-	-	-	-	-	-	-	-
	3	15	MC	1	7	MB	3	7	MB	3	7	MB
1	5	25	ME	5	25	ME	7½	25	ME	10	25	ME
	7½	40	MG	7½	40	MG	-	-	-	-	-	-
	10	60	MJ	10	60	MJ	-	-	-	-	-	-
2	15	75	-	15	75	-	15	40	MG	15	40	MG
	20	100	-	20	100	-	20	60	MJ	20	60	MJ
	25	100	-	25	100	-	25	60	MJ	25	60	MJ
3	30	150	-	30	150	-	30	60	MJ	30	60	MJ
	40	175	-	40	175	-	40	100	MN	40	100	MN
	50	200	-	50	200	-	50	100	MN	50	100	MN
4	60	200	-	60	200	-	60	100	MN	60	100	MN
	75	250	-	75	250	-	75	150	MR	75	150	MR
	100	250	-	100	250	-	100	150	MR	100	150	MR

Step 4 (digit 12) select overload relay

Overload relay	Code
Thermal bi-metallic ambient compensated (1 NC)	3
Thermal bi-metallic ambient compensated (1 NO-1 NC)	4
Solid state overload (1 NO-1 NC)	(#)

(#) Select code for solid state overload amp rating from standard or optional ranges table below.

Solid state overload relay — standard range

NEMA size	200–208 V		230–240 V		460–480 V		575–600 V	
	OL range	Code	OL range	Code	OL range	Code	OL range	Code
0	0.8–1.7	-	0.8–1.7	-	¾	D	1	D
	1.6–3.4	½	1.6–3.4	½	2	E	2	E
	3.2–6.8	1	3.2–6.8	1	3	F	5	F
1	6.5–13.5	3	6.5–13.5	3	5	G	-	-
	13–27	7½	13–27	7½	10	H	-	-
2	13–27	-	13–27	-	20	H	25	H
	25–50	10	25–50	10	25	J	-	-

Optional ranges

OL amp range	NEMA size	
	0 and 1	2
0.4–0.85	C	-
0.8–1.7	D	-
1.6–3.4	E	-
3.2–6.8	F	-
6.5–13.5	G	G
13–27	H	H
25–50	-	J
17–35	-	-
35–70	-	-
65–135	-	-

Enclosed combination magnetic starters

CR387 non-reversing, instantaneous trip circuit breaker

Ordering code configuration

Valid for NEMA sizes 0–2, type 1 standard enclosure

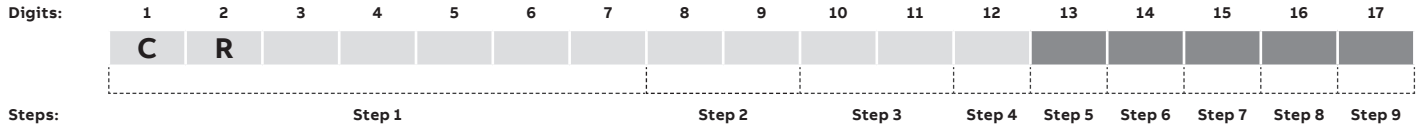

To configure the ordering code, use the tables below to fill in the digit boxes with the appropriate code.

Step 5 (digit 13) select auxiliary contacts

Auxiliary contacts	Code
None	A
1 NO	B
1 NC	C
1 NO–1 NC	D
2 NO	E
2 NC	F
2 NO–1 NC	G
1 NO–2 NC	H
3 NO	J
3 NC	K
4 NO	L ¹
4 NC	M ¹
2 NO–2 NC	N ¹
3 NO–1 NC	P ¹
1 NO–3 NC	R ¹

¹Exceeds maximum number of contacts for some pilot light selections. See step 8 (digit 16).

Step 6 (digit 14) select monitoring options

Device	Code
None ²	A

²Phase failure relay is not available for CR387 series standard enclosures. If this is required for your application, use CR487 series oversized enclosure.

Step 7 (digit 15) select pushbutton/selector switch

Pushbutton/selector switch - heavy duty	Code
None	A
Start/stop pushbutton	J
Hand-off-auto (HOA) selector switch	L
Off-on selector switch	M
HOA selector switch and start pushbutton	S
Keyed HOA selector switch, key removal center pos.	N

Step 8 (digit 16) select pilot device

Pilot light (heavy duty) type	Color — functionality	Code
None		A
LED lights	Red — across coil	1
	Green — across coil	2
	Red — thru NO aux contact	3 ³
	Green — thru NC aux contact	4 ³
	Red — thru NO aux contact and green — thru NC aux contact	5 ⁴
	Red — across coil and green — thru NC aux contact	6 ³
	Red — across coil and green — thru NC aux contact and unwired amber	7 ³
Push-to-test lights	Red — across coil	R
	Green — across coil	S
	Red — thru NO aux contact	C ³
	Green — thru NC aux contact	D ³
	Red — thru NO aux contact and green — thru NC aux contact	E ⁴
	Red — across coil and green — thru NC aux contact	V ³
	Red — across coil and green — thru NC aux contact and unwired amber	Y ³

³Maximum of 3 aux contacts may be added to sizes 0 and 1.

⁴Maximum of 2 aux contacts may be added to sizes 0 and 1. Maximum of 3 aux contacts may be added to sizes 2–4.

Note: Auxiliary contacts wired as part of pilot light selection are in addition to the auxiliary contacts selected from step 5 (digit 13), which are for customer/field connections.

Step 9 (digit 17) select control options

Device	Code
None	A

General note:

If selecting factory installed and wired operator devices (pushbuttons, selector switches and/or pilot lights), control circuit fusing, a control power transformer or 24 V/120 V separate sourced control is required, regardless of protective device rating.

Enclosed combination magnetic starters

CR487 non-reversing, instantaneous trip circuit breaker

Ordering code configuration

Valid for NEMA sizes 0–4

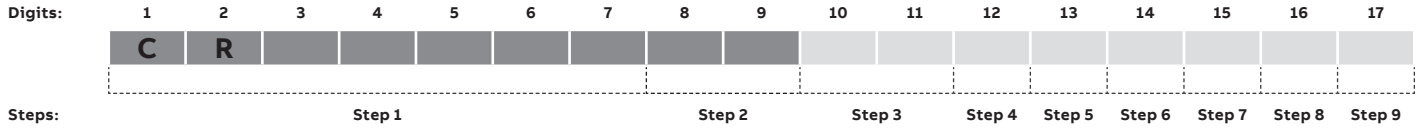

To configure the ordering code, use the tables below to fill in the digit boxes with the appropriate code.

Step 1 (digits 1–7) select NEMA size and enclosure

NEMA size	NEMA type 1		NEMA type 3R		NEMA type 12		NEMA type 4/4X	
	Standard enclosure	Oversized enclosure	Standard enclosure	Oversized enclosure	Standard enclosure	Oversized enclosure	Standard enclosure	Oversized enclosure
0	Use CR387	CR487B5	CR487B6	CR487BR	CR487B2	CR487B7	CR487B4	CR487B5
1	Use CR387	CR487C5	CR487C6	CR487CR	CR487C2	CR487C7	CR487C4	CR487CS
2	Use CR387	CR487D5	CR487D6	CR487DR	CR487D2	CR487D7	CR487D4	CR487DS
3	CR487E1	CR487E5	CR487E6	CR487ER	CR487E2	CR487E7	CR487E4	CR487ES
4	CR487F1	CR487F5	CR487F6	CR487FR	CR487F2	CR487F7	CR487F4	CR487FS

Note: All enclosures include external overload reset buttons. NEMA 4 enclosures are stainless steel.

Step 2 (digits 8, 9) select control voltage (no CPT and standard size CPT)

Control circuit voltage and CPT	Control fuses, no CPT		Standard size CPT
	No CPT	Control fuses, no CPT	
120 V with surge protector (SP)	01	F1	–
120 V	02	F2	–
240 V	03	F3	–
480 V	04	F4	–
600 V	05	F5	–
208 V	08	F8	–
24 V ¹	09	–	–
240 V/120 V with CPT	–	–	93
480 V/120 V with CPT	–	–	94
600 V/120 V with CPT	–	–	95
208 V/120 V with CPT	–	–	98
240 V/120 V with CPT and SP	–	–	33
480 V/120 V with CPT and SP	–	–	34
600 V/120 V with CPT and SP	–	–	35
208 V/120 V with CPT and SP	–	–	38
240 V/24 V with CPT ¹	–	–	S3
480 V/24 V with CPT ¹	–	–	S4
600 V/24 V with CPT ¹	–	–	S5
208 V/24 V with CPT ¹	–	–	S8

¹24 V coils not available for NEMA size 3 and 4.

Step 2 (digits 8, 9) select control voltage (extra capacity CPT + 100 VA and 200 VA)

Control circuit voltage and CPT	Standard size CPT + 100 VA	Standard size CPT + 200 VA
	120 V with surge protector (SP)	–
120 V	–	–
240 V	–	–
480 V	–	–
600 V	–	–
208 V	–	–
24 V ¹	–	–
240 V/120 V with CPT	13	23
480 V/120 V with CPT	14	24
600 V/120 V with CPT	15	25
208 V/120 V with CPT	18	28
240 V/120 V with CPT and SP	53	63
480 V/120 V with CPT and SP	54	64
600 V/120 V with CPT and SP	55	65
208 V/120 V with CPT and SP	58	68
240 V/24 V with CPT ¹	A3	B3
480 V/24 V with CPT ¹	A4	B4
600 V/24 V with CPT ¹	A5	B5
208 V/24 V with CPT ¹	A8	B8

Note: CPT includes 2 primary fuses and 1 secondary fuse.

¹24 V coils not available for NEMA size 3 and 4.

²Requires oversized enclosure for NEMA sizes 0–2. Select proper NEMA size and enclosure type from step 1 (digits 1–7) table, above.

Please reference the [NEMA full voltage power devices catalog](#) for additional technical data, selection and installation guides, and dimensional drawings.

Enclosed combination magnetic starters

CR487 non-reversing, instantaneous trip circuit breaker

Ordering code configuration

Valid for NEMA sizes 0–4

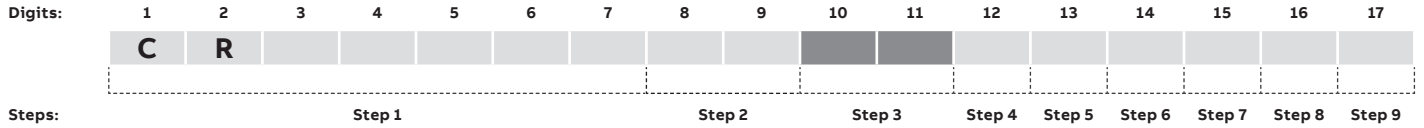

To configure the ordering code, use the tables below to fill in the digit boxes with the appropriate code.

Step 3 (digits 10, 11) select protective device

Instantaneous trip circuit breaker

NEMA size	208 V			240 V			480 V			600 V		
	Max. hp	CB rating (amps)	Code	Max. hp	CB rating (amps)	Code	Max. hp	CB rating (amps)	Code	Max. hp	CB rating (amps)	Code
0	0.5	3	MA	0.5	3	MA	1	3	MA	1	3	MA
	1	7	MB	–	–	–	–	–	–	–	–	–
	–	–	–	–	–	–	3	7	MB	3	7	MB
	3	15	MC	1	7	MB	–	–	–	–	–	–
1	–	–	–	3	15	MC	5	15	MC	5	15	MC
	5	25	ME	5	25	ME	7½	25	ME	10	25	ME
	–	–	–	–	–	–	10	25	ME	–	–	–
2	7½	40	MG	7½	40	MG	–	–	–	–	–	–
	–	–	–	–	–	–	15	40	MG	15	40	MG
	10	60	MJ	10	60	MJ	–	–	–	–	–	–
	–	–	–	–	–	–	–	–	–	–	–	–
	–	–	–	–	–	–	–	–	–	20	40	MG
	–	–	–	15	60	MJ	20	60	MJ	–	–	–
3	–	–	–	–	–	–	25	60	MJ	25	60	MJ
	–	–	–	–	–	–	30	60	MJ	30	60	MJ
	15	100	MN	20	100	MN	–	–	–	–	–	–
	–	–	–	–	–	–	–	–	–	40	60	MJ
	20	100	MN	25	100	MN	40	100	MN	–	–	–
4	25	100	MN	30	100	MN	50	100	MN	50	100	MN
	30	150	MR	–	–	–	60	100	MN	60	100	MN
	–	–	–	40	175	MS	–	–	–	–	–	–
	–	–	–	–	–	–	75	150	MR	75	150	MR
	–	–	–	–	–	–	–	–	–	100	150	MR
	40	175	MS	50	175	MS	100	175	MS	–	–	–

Please reference the [NEMA full voltage power devices catalog](#) for additional technical data, selection and installation guides, and dimensional drawings.

Enclosed combination magnetic starters

CR487 non-reversing, instantaneous trip circuit breaker

Ordering code configuration

Valid for NEMA sizes 0-4

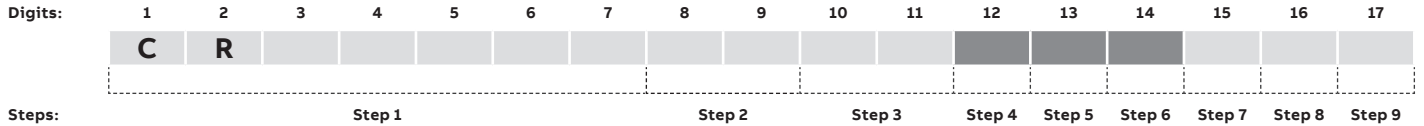

To configure the ordering code, use the tables below to fill in the digit boxes with the appropriate code.

Step 4 (digit 12) select overload relay

Overload relay	Code
Thermal bi-metallic ambient compensated (1 NC)	3
Thermal bi-metallic ambient compensated (1 NO-1 NC)	4
Solid state overload (1 NO-1 NC)	(#)

(#) Select code for solid state overload amp rating from standard or optional ranges table.

Solid state overload relay — standard range

NEMA size	200-208 V		230-240 V		460-480 V		575-600 V	
	OL range	Max. hp Code	Max. hp Code	Max. hp Code	Max. hp Code			
0	0.8 - 1.7	- -	- -	¾ -	D D			
	1.6 - 3.4	½ E	¾ E	2 E	2 E			
	3.2 - 6.8	1 F	2 F	3 F	5 F			
	6.5 - 13.5	3 G	3 G	5 G	- -			
1	6.5 - 13.5	- -	- -	7½ G	10 G			
	13 - 27	7½ H	7½ H	10 H	- -			
2	13 - 27	- -	- -	20 H	25 H			
	25 - 50	10 J	15 J	25 J	- -			
3	17 - 35	- -	- -	- -	30 K			
	35 - 70	20 L	25 L	50 L	50 L			
	65 - 135	25 M	30 M	- -	- -			
4	65 - 135	40 M	50 M	100 M	100 M			

Optional ranges

OL amp range	NEMA size		
	0 and 1	2	3 and 4
0.4-0.85	C	-	-
0.8-1.7	D	-	-
1.6-3.4	E	-	-
3.2-6.8	F	-	-
6.5-13.5	G	G	-
13-27	H	H	-
25-50	-	J	-
17-35	-	-	K
35-70	-	-	L
65-135	-	-	M

Step 5 (digit 13) select auxiliary contacts

Auxiliary contacts	Code
None	A
1 NO	B
1 NC	C
1 NO-1 NC	D
2 NO	E
2 NC	F
2 NO-1 NC	G
1 NO-2 NC	H
3 NO	J
3 NC	K
4 NO	L ³
4 NC	M ³
2 NO-2 NC	N ³
3 NO-1 NC	P ³
1 NO-3 NC	R ³

³Exceeds maximum number of contacts for some pilot light selections. See step 8 (digit 16).

Step 6 (digit 14) select monitoring options

Device	Code
None	A
Phase failure relay with undervoltage protection (panel mounted) — 190-480V (PFR with UV)	C ²
Phase failure relay with undervoltage protection (panel mounted) — 575V (PFR with UV)	D ²
Phase failure relay — 208 V (PFR)	E ^{4,6}
Phase failure relay — 240 V (PFR)	F ^{4,6}
Phase failure relay — 480 V (PFR)	G ^{4,6}
Phase failure relay — 575 V (PFR)	H ^{4,6}
Elapsed time meter (120 V/60 Hz) wired across coil (ETM)	I ^{2,5}
ETM + PFR with UV (190-480 V)	L ^{2,5,6}
ETM + PFR with UV (575 V)	N ^{2,5,6}
ETM + PFR (208 V)	P ^{2,4,5,6}
ETM + PFR (240 V)	Q ^{2,4,5,6}
ETM + PFR (480 V)	R ^{2,4,5,6}
ETM + PFR (575 V)	S ^{2,4,5,6}

²Requires oversized enclosure for NEMA sizes 0-2. Select proper NEMA size and enclosure type from step 1 (digits 1-7).

⁴Available for type 1 enclosure only.

⁵Requires 120 V control circuit voltage or CPT with 120 V secondary.

⁶Requires oversized enclosure for phase failure relay.

Enclosed combination magnetic starters

CR487 non-reversing, instantaneous trip circuit breaker

Ordering code configuration

Valid for NEMA sizes 0–4

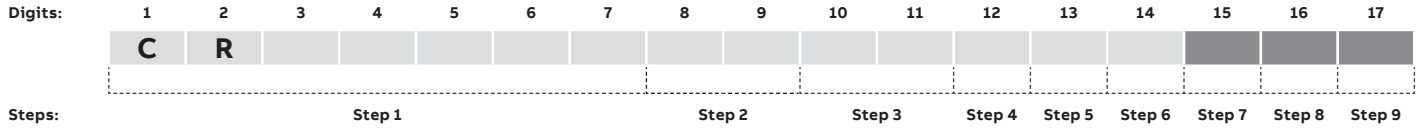

To configure the ordering code, use the tables below to fill in the digit boxes with the appropriate code.

Step 7 (digit 15) select pushbutton/selector switch

Pushbutton/selector switch — heavy duty	Code
None	A
Start/stop pushbutton	J
Hand-off-auto (HOA) selector switch	L
Off-on selector switch	M
HOA selector switch and start pushbutton	S
Keyed HOA selector switch, key removal center pos.	N

Step 8 (digit 16) select pilot device

Pilot light (heavy duty) type	Color — functionality	Code
None		A
LED lights	Red—across coil	1
	Green—across coil	2
	Red—thru NO aux contact	3 ⁷
	Green—thru NC aux contact	4 ⁷
	Red—thru NO aux contact and green—thru NC aux contact	5 ⁸
	Red—across coil and green—thru NC aux contact	6 ⁷
	Red—across coil and green—thru NC aux contact and unwired amber	7 ⁷
Push-to-test lights	Red—across coil	R
	Green—across coil	S
	Red—thru NO aux contact	C ⁷
	Green—thru NC aux contact	D ⁷
	Red—thru NO aux contact and green—thru NC aux contact	E ⁸
	Red—across coil and green—thru NC aux contact	V ⁷
	Red—across coil and green—thru NC aux contact and unwired amber	Y ⁷

⁷Maximum of 3 aux contacts may be added to sizes 0 and 1.

⁸Maximum of 2 aux contacts may be added to sizes 0 and 1. Maximum of 3 aux contacts may be added to sizes 2–4.

Note: Auxiliary contacts wired as part of pilot light selection are in addition to the auxiliary contacts selected from step 5 (digit 13), which are for customer/field connections.

Step 9 (digit 17) select control options

Device	Code
None	A
1 relay, 2 NO-2 NC, 24/120 V coil — unwired	B ^{2,9}
2 relays, 24/120 V coil — unwired	C ^{2,9}
DIN rail — for customer use	D ²
12 point terminal strip — unwired (12 PT strip)	E ²
Space heater with NC contact	H ^{2,10}
1 relay + 12 PT strip	J ^{2,9}
2 relays + 12 PT strip	K ^{2,9}
DIN rail + 12 PT strip + space heater	L ^{2,10}
2 relays + 12 PT strip + space heater	M ^{2,9,10}
Time delay on relay, 24/120 V coil — unwired (TD)	N ^{2,9}
Time delay off relay, 24/120 V coil — unwired (TD)	P ^{2,9}
12 PT strip + TD on	R ^{2,9}
12 PT strip + TD off	S ^{2,9}
12 PT strip + space heater + TD on	T ^{2,9,10}
12 PT strip + space heater + TD off	U ^{2,9,10}

²Requires oversized enclosure for NEMA sizes 0–2. Select proper NEMA size and enclosure type from step 1 (digits 1–7).

⁹Relay/timer coil voltage is equivalent to CPT secondary voltage. Requires minimum 100 extra VA CPT option.

¹⁰Maximum number of auxiliary contacts shall be reduced by 1.

General note:

If selecting factory installed and wired operator devices (pushbuttons, selector switches and/or pilot lights), control circuit fusing, a control power transformer or 24 V/120 V separate sourced control is required, regardless of protective device rating.

Enclosed combination magnetic starters

CR410 reversing, thermal magnetic circuit breaker

Ordering code configuration

Valid for NEMA sizes 0–4

Digits:	1	2	3	4	5	6	7	8	9	10	11	12	13	14	15	16	17
	C	R															
Steps:	Step 1							Step 2		Step 3		Step 4	Step 5	Step 6	Step 7	Step 8	Step 9

To configure the ordering code, use the tables below to fill in the digit boxes with the appropriate code.

Step 1 (digits 1-7) select NEMA size and enclosure

NEMA size	NEMA type 1	NEMA type 3R	NEMA type 12	NEMA type 4
	Standard enclosure	Standard enclosure	Standard enclosure	Standard enclosure
0	CR410B1	CR410B6	CR410B2	CR410B4
1	CR410C1	CR410C6	CR410C2	CR410C4
2	CR410D1	CR410D6	CR410D2	CR410D4
3	CR410E1	CR410E6	CR410E2	CR410E4
4	CR410F1	CR410F6	CR410F2	CR410F4

Note: All enclosures include external overload reset buttons. NEMA 4 enclosures are stainless steel.

Step 2 (digits 8, 9) select control voltage (no CPT and standard size CPT)

Control circuit voltage and CPT	No CPT	Control fuses, no CPT	Standard size CPT
120 V with surge protector (SP)	01	F1	–
120 V	02	F2	–
240 V	03	F3	–
480 V	04	F4	–
600 V	05	F5	–
208 V	08	F8	–
24 V ¹	09	–	–
240 V/120 V with CPT	–	–	93
480 V/120 V with CPT	–	–	94
600 V/120 V with CPT	–	–	95
208 V/120 V with CPT	–	–	98
240 V/120 V with CPT and SP	–	–	33
480 V/120 V with CPT and SP	–	–	34
600 V/120 V with CPT and SP	–	–	35
208 V/120 V with CPT and SP	–	–	38
240 V/24 V with CPT ¹	–	–	S3
480 V/24 V with CPT ¹	–	–	S4
600 V/24 V with CPT ¹	–	–	S5
208 V/24 V with CPT ¹	–	–	S8

Note: CPT includes 2 primary fuses and 1 secondary fuse.

¹24 V coils not available for NEMA size 3 and 4.

Please reference the [NEMA full voltage power devices catalog](#) for additional technical data, selection and installation guides, and dimensional drawings.

Enclosed combination magnetic starters

CR410 reversing, thermal magnetic circuit breaker

Ordering code configuration

Valid for NEMA sizes 0–4

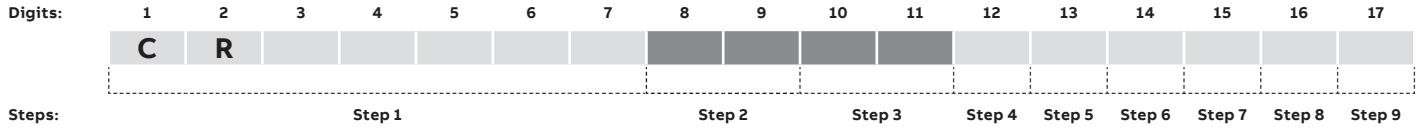

To configure the ordering code, use the tables below to fill in the digit boxes with the appropriate code.

Step 2 (digits 8, 9) select control voltage (extra capacity CPT + 100 VA and 200 VA) (continued)

Control circuit voltage and CPT	Standard size CPT + 100 VA	Standard size CPT + 200 VA
120 V with surge protector (SP)	–	–
120 V	–	–
240 V	–	–
480 V	–	–
600 V	–	–
208 V	–	–
24 V ¹	–	–
240 V/120 V with CPT	13	23
480 V/120 V with CPT	14	24
600 V/120 V with CPT	15	25
208 V/120 V with CPT	18	28
240 V/120 V with CPT and SP	53	63
480 V/120 V with CPT and SP	54	64
600 V/120 V with CPT and SP	55	65
208 V/120 V with CPT and SP	58	68
240 V/24 V with CPT ¹	A3	B3
480 V/24 V with CPT ¹	A4	B4
600 V/24 V with CPT ¹	A5	B5
208 V/24 V with CPT ¹	A8	B8

Note: CPT includes 2 primary fuses and 1 secondary fuse.

¹24 V coils not available for NEMA size 3 and 4.

Step 3 (digits 10, 11) select protective device

Thermal-magnetic circuit breaker

NEMA size	200–208 V			240 V			480 V			600 V		
	Max. hp	CB rating (amps)	Code	Max. hp	CB rating (amps)	Code	Max. hp	CB rating (amps)	Code	Max. hp	CB rating (amps)	Code
0	2	15	TC	3	15	TC	5	15	TC	5	15	TC
	3	15	TC	–	–	–	–	–	–	–	–	–
1	–	–	–	–	–	–	–	–	–	7½	15	TC
	5	25	TE	5	25	TE	7½	25	TE	–	–	–
2	–	–	–	–	–	–	–	–	–	10	25	TE
	7½	40	TG	7½	40	TG	10	25	TE	10	20	TD
	–	–	–	–	–	–	15	40	TG	15	40	TG
	10	60	TJ	10	60	TJ	–	–	–	–	–	–
3	–	–	–	–	–	–	–	–	–	20	40	TG
	–	–	–	15	60	TJ	20	60	TJ	–	–	–
	–	–	–	–	–	–	25	60	TJ	25	60	TJ
	–	–	–	–	–	–	30	60	TJ	30	60	TJ
4	15	100	TN	20	100	TN	–	–	–	–	–	–
	–	–	–	–	–	–	–	–	–	40	60	TJ
	20	100	TN	25	100	TN	40	100	TN	–	–	–
	–	–	–	–	–	–	50	100	TN	50	100	TN
4	25	125	TQ	30	125	TQ	–	–	–	–	–	–
	–	–	–	–	–	–	60	150	TR	60	150	TR
	30	150	TR	–	–	–	–	–	–	–	–	–
	–	–	–	40	200	TT	–	–	–	–	–	–
4	–	–	–	–	–	–	75	150	TR	75	150	TR
	40	200	TT	50	200	TT	–	–	–	–	–	–
	–	–	–	–	–	–	100	200	TT	100	200	TT

Enclosed combination magnetic starters

CR410 reversing, thermal magnetic circuit breaker

Ordering code configuration

Valid for NEMA sizes 0–4

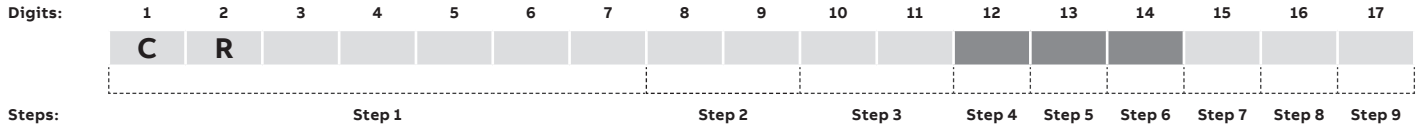

To configure the ordering code, use the tables below to fill in the digit boxes with the appropriate code.

Step 4 (digit 12) select overload relay

Overload relay	Code
Thermal bi-metallic ambient compensated (1 NC)	3
Thermal bi-metallic ambient compensated (1 NO–1 NC)	4
Solid state overload (1 NO–1 NC)	(#)

(#) Select code for solid state overload amp rating from standard or optional ranges table below.

Solid state overload relay — standard range

NEMA size	OL range	200–208 V		230–240 V		460–480 V		575–600 V	
		Max. hp	Code	Max. hp	Code	Max. hp	Code	Max. hp	Code
0	0.8–1.7	–	–	–	–	¾	D	1	D
	1.6–3.4	½	E	¾	E	2	E	2	E
	3.2–6.8	1	F	2	F	3	F	5	F
	6.5–13.5	3	G	3	G	5	G	–	–
1	6.5–13.5	–	–	–	–	7½	G	10	G
	13–27	7½	H	7½	H	10	H	–	–
2	13–27	–	–	–	–	20	H	25	H
	25–50	10	J	15	J	25	J	–	–
3	17–35	–	–	–	–	–	–	30	K
	35–70	20	L	25	L	50	L	50	L
	65–135	25	M	30	M	–	–	–	–
4	65–135	40	M	50	M	100	M	100	M

Optional ranges

OL amp range	NEMA size		
	0 and 1	2	3 and 4
0.4–0.85	C	–	–
0.8–1.7	D	–	–
1.6–3.4	E	–	–
3.2–6.8	F	–	–
6.5–13.5	G	G	–
13–27	H	H	–
25–50	–	J	–
17–35	–	–	K
35–70	–	–	L
65–135	–	–	M

Step 5 (digit 13) select auxiliary contacts

Auxiliary contacts (per contactor)	Code
None	A
1 NO	B
1 NC	C
1 NO–1 NC	D
2 NO	E
2 NC	F

Step 6 (digit 14) select monitoring options

Device	Code
None	A
Phase failure relay with undervoltage protection (panel mounted) — 190–480 V (PFR with UV)	C
Phase failure relay with undervoltage protection (panel mounted) — 575 V (PFR with UV)	D
Phase failure relay — 208 V (PFR)	E ²
Phase failure relay — 240 V (PFR)	F ²
Phase failure relay — 480 V (PFR)	G ²
Phase failure relay — 575 V (PFR)	H ²
Elapsed time meter (120 V/60 Hz) wired across coil (ETM)	I ³
ETM + PFR with UV (190–480 V)	L ³
ETM + PFR with UV (575 V)	N ³
ETM + PFR (208 V)	P ^{2,3}
ETM + PFR (240 V)	Q ^{2,3}
ETM + PFR (480 V)	R ^{2,3}
ETM + PFR (575 V)	S ^{2,3}

²Available for type 1 enclosure only.

³Requires 120 V control circuit voltage or CPT with 120 V secondary.

Please reference the [NEMA full voltage power devices catalog](#) for additional technical data, selection and installation guides, and dimensional drawings.

Enclosed combination magnetic starters

CR410 reversing, thermal magnetic circuit breaker

Ordering code configuration

Valid for NEMA sizes 0–4

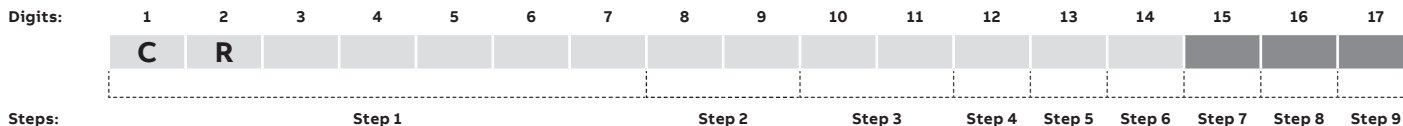

To configure the ordering code, use the tables below to fill in the digit boxes with the appropriate code.

Step 7 (digit 15) select pushbutton/selector switch

Pushbutton/selector switch — heavy duty	Code
None	A
Fwd/rev/stop pushbutton	J
Up/down/stop pushbutton	K
Open/CLS/stop pushbutton	L
HOA and fwd-rev selector switch	P
Fwd-off-rev selector switch	T

Step 8 (digit 16) select pilot device

Pilot light (heavy duty CR104P style) type	Color — functionality	Code
None		A
LED lights	Red and amber across coils	2
	Red and green across coils	3
	Red and amber across coils and unwired green	5
Push-to-test lights	Red and amber across coils	S
	Red and green across coils	T
	Red and amber across coils and unwired green	Y

Step 9 (digit 17) select control options

Device	Code
None	A
1 relay, 2 NO-2 NC, 24/120 V coil — unwired	B ⁴
2 relays, 24/120 V coil — unwired	C ⁴
DIN rail - for customer use	D
12 point terminal strip — unwired (12 PT strip)	E
Space heater with NC contact	H ⁵
1 relay + 12 PT strip	J ⁴
2 relays + 12 PT strip	K ⁴
DIN rail + 12 PT strip + space heater	L ⁵
2 relays + 12 PT strip + space heater	M ^{4,5}
Time delay on relay, 24/120 V coil — unwired (TD)	N ⁴
Time delay off relay, 24/120 V coil — unwired (TD)	P ⁴
12 PT strip + TD ON	R ⁴
12 PT strip + TD OFF	S ⁴
12 PT strip + space heater + TD ON	T ^{4,5}
12 PT strip + space heater + TD OFF	U ^{4,5}

⁴Relay/timer coil voltage is equivalent to CPT secondary voltage. Requires minimum 100 extra VA CPT option.

⁵Maximum number of auxiliary contacts shall be reduced by 1.

General note:

On NEMA size 3 and 4 starters, if selecting factory installed and wired operator devices (pushbuttons, selector switches and/or pilot lights), then control circuit fusing, a control power transformer or 120 V separate sourced control is required when the protective device is rated greater than 100 amps.

Enclosed combination magnetic starters

CR411 reversing, disconnect switch

Ordering code configuration

Valid for NEMA sizes 0–4

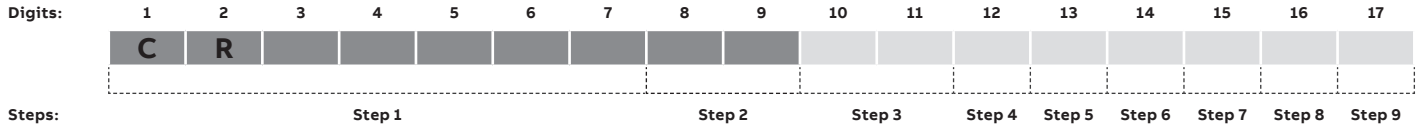

To configure the ordering code, use the tables below to fill in the digit boxes with the appropriate code.

Step 1 (digits 1–7) select NEMA size and enclosure

NEMA size	NEMA type 1	NEMA type 3R	NEMA type 12	NEMA type 4
	Standard enclosure	Standard enclosure	Standard enclosure	Standard enclosure
0	CR411B1	CR411B6	CR411B2	CR411B4
1	CR411C1	CR411C6	CR411C2	CR411C4
2	CR411D1	CR411D6	CR411D2	CR411D4
3	CR411E1	CR411E6	CR411E2	CR411E4
4	CR411F1	CR411F6	CR411F2	CR411F4

Note: All enclosures include external overload reset buttons. NEMA 4 enclosures are stainless steel.

Step 2 (digits 8, 9) select control voltage (no CPT and standard size CPT)

Control circuit voltage and CPT	No CPT	Control fuses, no CPT	Standard size CPT
120 V with surge protector (SP)	01	F1	–
120 V	02	F2	–
240 V	03	F3	–
480 V	04	F4	–
600 V	05	F5	–
208 V	08	F8	–
24 V ¹	09	–	–
240 V/120 V with CPT	–	–	93
480 V/120 V with CPT	–	–	94
600 V/120 V with CPT	–	–	95
208 V/120 V with CPT	–	–	98
240 V/120 V with CPT and SP	–	–	33
480 V/120 V with CPT and SP	–	–	34
600 V/120 V with CPT and SP	–	–	35
208 V/120 V with CPT and SP	–	–	38
240 V/24 V with CPT ¹	–	–	S3
480 V/24 V with CPT ¹	–	–	S4
600 V/24 V with CPT ¹	–	–	S5
208 V/24 V with CPT ¹	–	–	S8

Note: CPT includes 2 primary fuses and 1 secondary fuse.
¹24 V coils not available for NEMA size 3 and 4.

Please reference the [NEMA full voltage power devices catalog](#) for additional technical data, selection and installation guides, and dimensional drawings.

Enclosed combination magnetic starters

CR411 reversing, disconnect switch

Ordering code configuration

Valid for NEMA sizes 0–4

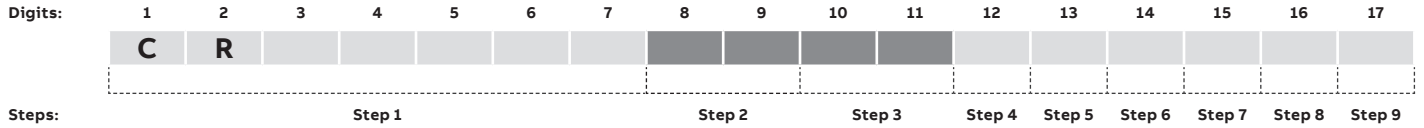

To configure the ordering code, use the tables below to fill in the digit boxes with the appropriate code.

Step 2 (digits 8, 9) select control voltage (extra capacity CPT + 100 VA and 200 VA) (continued)

Control circuit voltage and CPT	Standard size CPT + 100 VA	Standard size CPT + 200 VA
120 V with surge protector (SP)	–	–
120 V	–	–
240 V	–	–
480 V	–	–
600 V	–	–
208 V	–	–
24 V ¹	–	–
240 V/120 V with CPT	13	23
480 V/120 V with CPT	14	24
600 V/120 V with CPT	15	25
208 V/120 V with CPT	18	28
240 V/120 V with CPT and SP	53	63
480 V/120 V with CPT and SP	54	64
600 V/120 V with CPT and SP	55	65
208 V/120 V with CPT and SP	58	68
240 V/24 V with CPT ¹	A3	B3
480 V/24 V with CPT ¹	A4	B4
600 V/24 V with CPT ¹	A5	B5
208 V/24 V with CPT ¹	A8	B8

Note: CPT includes 2 primary fuses and 1 secondary fuse.
¹24 V coils not available for NEMA size 3 and 4.

Step 3 (digits 10, 11) select protective device

Disconnect without fuse clips

NEMA size	Code
All	1A

Disconnect with class H fuse clips — for use with non-time delay/single element class H fuses

NEMA size	200–208 V			230–240 V			460–480 V			575–600 V		
	Max. hp	Fuse clip (amps)	Code	Max. hp	Fuse clip (amps)	Code	Max. hp	Fuse clip (amps)	Code	Max. hp	Fuse clip (amps)	Code
0	3	30	HA	3	30	HA	5	30	H3	5	30	H3
1	–	–	–	–	–	–	7½	30	H3	10	30	H3
	7½	60	HB	7½	60	HB	10	60	H6	–	60	H6
2	–	–	–	–	–	–	15	60	H6	20	60	H6
	10	100	HC	15	100	HC	25	100	H1	25	100	H1
3	–	–	–	–	–	–	30	100	H1	30	100	H1
	25	200	HD	30	200	HD	50	200	H2	50	200	H2
4	–	–	–	–	–	–	60	200	H2	60	200	H2
	40	400	HE	50	400	HE	100	400	H4	100	400	H4

Enclosed combination magnetic starters

CR411 reversing, disconnect switch

Ordering code configuration

Valid for NEMA sizes 0–4

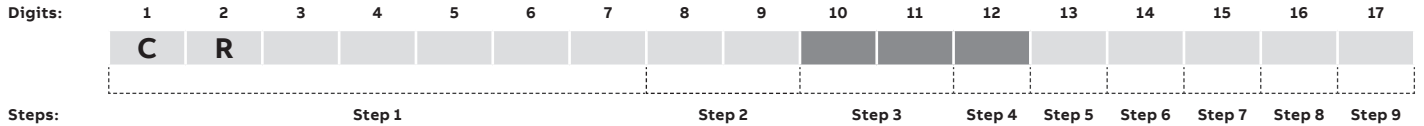

To configure the ordering code, use the tables below to fill in the digit boxes with the appropriate code.

Step 3 (digits 10, 11) select protective device (continued)

Disconnect with class R fuse clips — for use with time delay/dual element class RK1/RK5 fuses

NEMA size	200–208 V			230–240 V			460–480 V			575–600 V		
	Max. hp	Fuse clip (amps)	Code	Max. hp	Fuse clip (amps)	Code	Max. hp	Fuse clip (amps)	Code	Max. hp	Fuse clip (amps)	Code
0	3	30	RA	3	30	RA	5	30	R3	5	30	R3
1	5	30	RA	5	30	RA	10	30	R3	10	30	R3
	7½	60	RB	7½	60	RB	–	–	–	–	–	–
2	–	–	–	–	–	–	–	30	R3	15	30	R3
	10	60	RB	15	60	RB	25	60	R6	25	60	R6
3	–	–	–	–	–	–	–	60	R6	30	60	R6
	20	100	RC	25	100	RC	50	100	R1	50	100	R1
4	25	200	RD	30	200	RD	–	–	–	–	–	–
	–	–	–	–	–	–	–	100	R1	60	100	R1
	400	200	RD	50	200	RD	100	200	R2	100	200	R2

Disconnect with class J fuse clips — for use with time delay/dual element class J fuses

NEMA size	200–208 V			230–240 V			460–480 V			575–600 V		
	Max. hp	Fuse clip (amps)	Code	Max. hp	Fuse clip (amps)	Code	Max. hp	Fuse clip (amps)	Code	Max. hp	Fuse clip (amps)	Code
0	3	30	J3	3	30	J3	5	30	J3	5	30	J3
1	5	30	J3	5	30	J3	10	30	J3	10	30	J3
	7½	60	J6	7½	60	J6	–	–	–	–	–	–
2	–	–	–	–	–	–	–	30	J3	15	30	J3
	10	60	J6	15	60	J6	25	60	J6	25	60	J6
3	–	–	–	–	–	–	–	60	J6	30	60	J6
	20	100	J1	25	100	J1	50	100	J1	50	100	J1
4	25	200	J2	30	200	J2	–	–	–	–	–	–
	–	–	–	–	–	–	–	100	J1	60	100	J1
	40	200	J2	50	200	J2	100	200	J2	100	200	J2

Step 4 (digit 12) select overload relay

Overload relay	Code
Thermal bi-metallic ambient compensated (1 NC)	3
Thermal bi-metallic ambient compensated (1 NO–1 NC)	4
Solid state overload (1 NO–1 NC)	(#)

(#) Select code for solid state overload amp rating from standard or optional ranges table at right.

Solid state overload relay — standard range

NEMA size	200–208 V		230–240 V		460–480 V		575–600 V	
	OL range	Max. hp	Code	Max. hp	Code	Max. hp	Code	
0	0.8–1.7	–	–	–	¾	D	1	
1	1.6–3.4	½	E	¾	E	2	E	
	3.2–6.8	1	F	2	F	3	F	
2	6.5–13.5	3	G	3	G	5	G	
	6.5–13.5	–	–	–	7½	G	10	
3	13–27	7½	H	7½	H	10	H	
	13–27	–	–	–	20	H	25	
4	25–50	10	J	15	J	25	J	
	17–35	–	–	–	–	30	K	
3	35–70	20	L	25	L	50	L	
	65–135	25	M	30	M	–	–	
4	65–135	40	M	50	M	100	M	

Optional ranges

OL amp range	NEMA size 0 and 1	NEMA size 2 3 and 4
0.4–0.85	C	–
0.8–1.7	D	–
1.6–3.4	E	–
3.2–6.8	F	–
6.5–13.5	G	G
13–27	H	H
25–50	–	J
17–35	–	–
35–70	–	–
65–135	–	–

Enclosed combination magnetic starters

CR411 reversing, disconnect switch

Ordering code configuration

Valid for NEMA sizes 0–4



To configure the ordering code, use the tables below to fill in the digit boxes with the appropriate code.

Step 5 (digit 13) select auxiliary contacts

Auxiliary contacts (per contactor)	Code
None	A
1 NO	B
1 NC	C
1 NO–1 NC	D
2 NO	E
2 NC	F

Step 6 (digit 14) select monitoring options

Device	Code
None	A
Phase failure relay with undervoltage protection (panel mounted) — 190–480 V (PFR with UV)	C
Phase failure relay with undervoltage protection (panel mounted) — 575 V (PFR with UV)	D
Phase failure relay — 208 V (PFR)	E ²
Phase failure relay — 240 V (PFR)	F ²
Phase failure relay — 480 V (PFR)	G ²
Phase failure relay — 575 V (PFR)	H ²
Elapsed time meter (120 V/60 Hz) wired across coil (ETM)	I ³
ETM + PFR with UV (190–480 V)	L ³
ETM + PFR with UV (575 V)	N ³
ETM + PFR (208 V)	P ^{2,3}
ETM + PFR (240 V)	Q ^{2,3}
ETM + PFR (480 V)	R ^{2,3}
ETM + PFR (575 V)	S ^{2,3}

²Available for type 1 enclosure only.

³Requires 120 V control circuit voltage or CPT with 120 V secondary.

Step 7 (digit 15) select pushbutton/selector switch

Pushbutton/selector switch — heavy duty	Code
None	A
Fwd/rev/stop pushbutton	J
Up/down/stop pushbutton	K
Open/CLS/stop pushbutton	L
Hand-off-auto and fwd-rev selector switch	P
Fwd-off-rev selector switch	T

Please reference the [NEMA full voltage power devices catalog](#) for additional technical data, selection and installation guides, and dimensional drawings.

Enclosed combination magnetic starters

CR490 reversing, instantaneous trip circuit breaker

Ordering code configuration

Valid for NEMA sizes 0–4

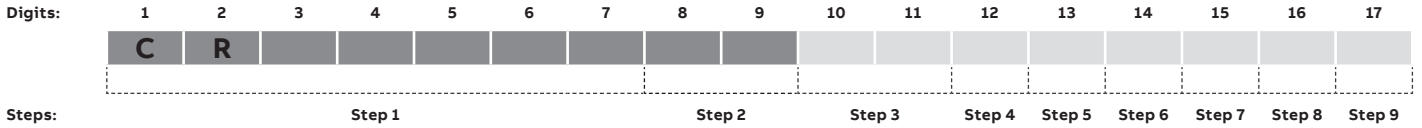

To configure the ordering code, use the tables below to fill in the digit boxes with the appropriate code.

Step 1 (digits 1–7) select NEMA size and enclosure

NEMA size	NEMA type 1	NEMA type 3R	NEMA type 12	NEMA type 4
	Standard enclosure	Standard enclosure	Standard enclosure	Standard enclosure
0	CR490B1	CR490B6	CR490B2	CR490B4
1	CR490C1	CR490C6	CR490C2	CR490C4
2	CR490D1	CR490D6	CR490D2	CR490D4
3	CR490E1	CR490E6	CR490E2	CR490E4
4	CR490F1	CR490F6	CR490F2	CR490F4

Note: All enclosures include external overload reset buttons. NEMA 4 enclosures are stainless steel.

Step 2 (digits 8, 9) select control voltage (no CPT and standard size CPT)

Control circuit voltage and CPT	No CPT	Control fuses, no CPT	Standard size CPT
120 V with surge protector (SP)	01	F1	–
120 V	02	F2	–
240 V	03	F3	–
480 V	04	F4	–
600 V	05	F5	–
208 V	08	F8	–
24 V ¹	09	–	–
240 V/120 V with CPT	–	–	93
480 V/120 V with CPT	–	–	94
600 V/120 V with CPT	–	–	95
208 V/120 V with CPT	–	–	98
240 V/120 V with CPT and SP	–	–	33
480 V/120 V with CPT and SP	–	–	34
600 V/120 V with CPT and SP	–	–	35
208 V/120 V with CPT and SP	–	–	38
240 V/24 V with CPT ¹	–	–	S3
480 V/24 V with CPT ¹	–	–	S4
600 V/24 V with CPT ¹	–	–	S5
208 V/24 V with CPT ¹	–	–	S8

Note: CPT includes 2 primary fuses and 1 secondary fuse.

¹24 V coils not available for NEMA size 3 and 4.

Please reference the [NEMA full voltage power devices catalog](#) for additional technical data, selection and installation guides, and dimensional drawings.

Enclosed combination magnetic starters

CR490 reversing, instantaneous trip circuit breaker

Ordering code configuration

Valid for NEMA sizes 0–4



To configure the ordering code, use the tables below to fill in the digit boxes with the appropriate code.

Step 2 (digits 8, 9) select control voltage (extra capacity CPT + 100 VA and 200 VA) (continued)

Control circuit voltage and CPT	Standard size CPT + 100 VA	Standard size CPT + 200 VA
120 V with surge protector (SP)	–	–
120 V	–	–
240 V	–	–
480 V	–	–
600 V	–	–
208 V	–	–
24 V ¹	–	–
240 V/120 V with CPT	13	23
480 V/120 V with CPT	14	24
600 V/120 V with CPT	15	25
208 V/120 V with CPT	18	28
240 V/120 V with CPT and SP	53	63
480 V/120 V with CPT and SP	54	64
600 V/120 V with CPT and SP	55	65
208 V/120 V with CPT and SP	58	68
240 V/24 V with CPT ¹	A3	B3
480 V/24 V with CPT ¹	A4	B4
600 V/24 V with CPT ¹	A5	B5
208 V/24 V with CPT ¹	A8	B8

Note: CPT includes 2 primary fuses and 1 secondary fuse.

¹24 V coils not available for NEMA size 3 and 4.

Step 3 (digits 10, 11) select protective device

Instantaneous trip circuit breaker

NEMA size	208 V			240 V			480 V			600 V		
	Max. hp	CB rating (amps)	Code	Max. hp	CB rating (amps)	Code	Max. hp	CB rating (amps)	Code	Max. hp	CB rating (amps)	Code
0	0.5	3	MA	0.5	3	MA	1	3	MA	1	3	MA
	1	7	MB	–	–	–	–	–	–	–	–	–
	–	–	–	–	–	–	3	7	MB	3	7	MB
	3	15	MC	1	7	MB	–	–	–	–	–	–
1	–	–	–	3	15	MC	5	15	MC	5	15	MC
	5	25	ME	5	25	ME	7½	25	ME	10	25	ME
	–	–	–	–	–	–	10	25	ME	–	–	–
	7½	40	MG	7½	40	MG	–	–	–	–	–	–
2	–	–	–	–	–	–	15	40	MG	15	40	MG
	10	60	MJ	10	60	MJ	–	–	–	–	–	–
	–	–	–	–	–	–	–	–	–	–	–	–
	–	–	–	–	–	–	–	–	–	20	40	MG
3	–	–	–	15	60	MJ	20	60	MJ	–	–	–
	–	–	–	–	–	–	25	60	MJ	25	60	MJ
	–	–	–	–	–	–	30	60	MJ	30	60	MJ
	15	100	MN	20	100	MN	–	–	–	–	–	–
4	–	–	–	–	–	–	–	–	–	40	60	MJ
	20	100	MN	25	100	MN	40	100	MN	–	–	–
	25	100	MN	30	100	MN	50	100	MN	50	100	MN
	30	150	MR	–	–	–	60	100	MN	60	100	MN
4	–	–	–	40	175	MS	–	–	–	–	–	–
	–	–	–	–	–	–	75	150	MR	75	150	MR
	–	–	–	–	–	–	–	–	–	100	150	MR
	40	175	MS	50	175	MS	100	175	MS	–	–	–

Enclosed combination magnetic starters

CR490 reversing, instantaneous trip circuit breaker

Ordering code configuration

Valid for NEMA sizes 0–4

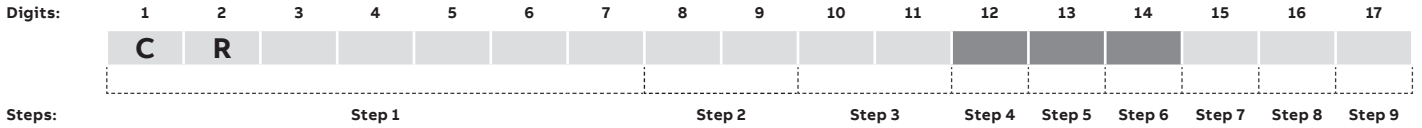

To configure the ordering code, use the tables below to fill in the digit boxes with the appropriate code.

Step 4 (digit 12) select overload relay

Overload relay	Code
Thermal bi-metallic ambient compensated (1 NC)	3
Thermal bi-metallic ambient compensated (1 NO–1 NC)	4
Solid state overload (1 NO–1 NC)	(#)

(#) Select code for solid state overload amp rating from standard or optional ranges table below.

Solid state overload relay — standard range

NEMA size	OL range	200–208 V		230–240 V		460–480 V		575–600 V	
		Max. hp	Code	Max. hp	Code	Max. hp	Code	Max. hp	Code
0	0.8–1.7	–	–	–	–	¾	D	1	D
	1.6–3.4	½	E	¾	E	2	E	2	E
	3.2–6.8	1	F	2	F	3	F	5	F
	6.5–13.5	3	G	3	G	5	G	–	–
1	6.5–13.5	–	–	–	–	7½	G	10	G
	13–27	7½	H	7½	H	10	H	–	–
2	13–27	–	–	–	–	20	H	25	H
	25–50	10	J	15	J	25	J	–	–
3	17–35	–	–	–	–	–	–	30	K
	35–70	20	L	25	L	50	L	50	L
	65–135	25	M	30	M	–	–	–	–
4	65–135	40	M	50	M	100	M	100	M

Optional ranges

OL amp range	NEMA size		
	0 and 1	2	3 and 4
0.4–0.85	C	–	–
0.8–1.7	D	–	–
1.6–3.4	E	–	–
3.2–6.8	F	–	–
6.5–13.5	G	G	–
13–27	H	H	–
25–50	–	J	–
17–35	–	–	K
35–70	–	–	L
65–135	–	–	M

Step 5 (digit 13) select auxiliary contacts

Aux contacts	Code
None	A
1 NO	B
1 NC	C
1 NO–1 NC	D
2 NO	E
2 NC	F

Step 6 (digit 14) select monitoring options

Device	Code
None	A
Phase failure relay with undervoltage protection (panel mounted) — 190–480 V (PFR with UV)	C
Phase failure relay with undervoltage protection (panel mounted) — 575 V (PFR with UV)	D
Phase failure relay — 208 V (PFR)	E ²
Phase failure relay — 240 V (PFR)	F ²
Phase failure relay — 480 V (PFR)	G ²
Phase failure relay — 575 V (PFR)	H ²
Elapsed time meter (120 V/60 Hz) wired across coil (ETM)	I ³
ETM + PFR with UV (190–480 V)	L ³
ETM + PFR with UV (575 V)	N ³
ETM + PFR (208 V)	P ^{2,3}
ETM + PFR (240 V)	Q ^{2,3}
ETM + PFR (480 V)	R ^{2,3}
ETM + PFR (575 V)	S ^{2,3}

²Available for type 1 enclosure only.

³Requires 120 V control circuit voltage or CPT with 120 V secondary.

Enclosed combination magnetic starters

CR490 reversing, instantaneous trip circuit breaker

Ordering code configuration

Valid for NEMA sizes 0–4

Digits:	1	2	3	4	5	6	7	8	9	10	11	12	13	14	15	16	17	
	C	R																
Steps:	Step 1			Step 2			Step 3		Step 4		Step 5		Step 6		Step 7		Step 8	Step 9

To configure the ordering code, use the tables below to fill in the digit boxes with the appropriate code.

Step 7 (digit 15) select pushbutton/selector switch

Pushbutton/selector switch — heavy duty	Code
None	A
Fwd/rev/stop pushbutton	J
Up/down/stop pushbutton	K
Open/CLS/stop pushbutton	L
Hand-off-auto and fwd-rev selector switch	P
Fwd-off-rev selector switch	T

Step 8 (digit 16) select pilot device

Pilot light (heavy duty CR104P style) type	Color — functionality	Code
None		A
LED lights	Red and amber across coils	2
	Red and green across coils	3
	Red and amber across coils and unwired green	5
Push-to-test lights	Red and amber across coils	S
	Red and green across coils	T
	Red and amber across coils and unwired green	Y

Step 9 (digit 17) select control options

Device	Code
None	A
1 relay, 2 NO-2 NC, 24/120 V coil — unwired	B ⁴
2 relays, 24/120 V coil — unwired	C ⁴
DIN rail — for customer use	D
12 point terminal strip — unwired (12 PT strip)	E
Space heater with NC contact	H ⁵
1 relay + 12 PT strip	J ⁴
2 relays + 12 PT strip	K ⁴
DIN rail + 12 PT strip + space heater	L ⁵
2 relays + 12 PT strip + space heater	M ^{4,5}
Time delay on relay, 24/120 V coil — unwired (TD)	N ⁴
Time delay off relay, 24/120 V coil — unwired (TD)	P ⁴
12 PT strip + TD ON	R ⁴
12 PT strip + TD OFF	S ⁴
12 PT strip + space heater + TD ON	T ^{4,5}
12 PT strip + space heater + TD OFF	U ^{4,5}

⁴Relay/timer coil voltage is equivalent to CPT secondary voltage. Requires minimum 100 extra VA CPT option.

⁵Maximum number of auxiliary contacts shall be reduced by 1.

General note:

If selecting factory installed and wired operator devices (pushbuttons, selector switches and/or pilot lights), control circuit fusing, a control power transformer or 24 V/120 V separate sourced control is required, regardless of protective device rating.

Enclosed combination magnetic starters

CR412 2-speed/1-winding, thermal magnetic circuit breaker

Ordering code configuration

Valid for NEMA sizes 0–4

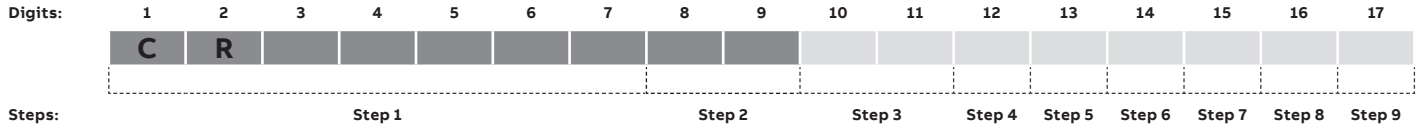

To configure the ordering code, use the tables below to fill in the digit boxes with the appropriate code.

Step 1 (digits 1–7) select NEMA size and enclosure

NEMA size	NEMA type 1	NEMA type 3R	NEMA type 12	NEMA type 4
	Standard enclosure	Standard enclosure	Standard enclosure	Standard enclosure
0	CR412B1	CR412B6	CR412B2	CR412B4
1	CR412C1	CR412C6	CR412C2	CR412C4
2	CR412D1	CR412D6	CR412D2	CR412D4
3	CR412E1	CR412E6	CR412E2	CR412E4
4	CR412F1	CR412F6	CR412F2	CR412F4

Note: All enclosures include external overload reset buttons. NEMA 4 enclosures are stainless steel.

Step 2 (digits 8, 9) select control voltage (no CPT and standard size CPT)

Control circuit voltage and CPT	No CPT	Control fuses, no CPT	Standard size CPT
120 V with surge protector (SP)	01	F1	–
120 V	02	F2	–
240 V	03	F3	–
480 V	04	F4	–
600 V	05	F5	–
208 V	08	F8	–
24 V ¹	09	–	–
240 V/120 V with CPT	–	–	93
480 V/120 V with CPT	–	–	94
600 V/120 V with CPT	–	–	95
208 V/120 V with CPT	–	–	98
240 V/120 V with CPT and SP	–	–	33
480 V/120 V with CPT and SP	–	–	34
600 V/120 V with CPT and SP	–	–	35
208 V/120 V with CPT and SP	–	–	38
240 V/24 V with CPT ¹	–	–	S3
480 V/24 V with CPT ¹	–	–	S4
600 V/24 V with CPT ¹	–	–	S5
208 V/24 V with CPT ¹	–	–	S8

Note: CPT includes 2 primary fuses and 1 secondary fuse.

¹24 V coils not available for NEMA size 3 and 4.

Please reference the [NEMA full voltage power devices catalog](#) for additional technical data, selection and installation guides, and dimensional drawings.

Enclosed combination magnetic starters

CR412 2-speed/1-winding, thermal magnetic circuit breaker

Ordering code configuration

Valid for NEMA sizes 0–4

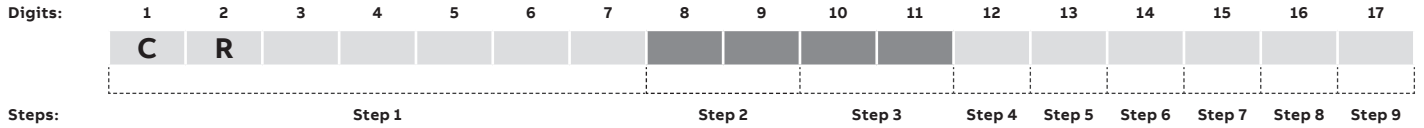

To configure the ordering code, use the tables below to fill in the digit boxes with the appropriate code.

Step 2 (digits 8, 9) select control voltage (extra capacity CPT + 100 VA and 200 VA) (continued)

Control circuit voltage and CPT	Standard size CPT + 100 VA	Standard size CPT + 200 VA
120 V with surge protector (SP)	-	-
120 V	-	-
240 V	-	-
480 V	-	-
600 V	-	-
208 V	-	-
24 V ¹	-	-
240 V/120 V with CPT	13	23
480 V/120 V with CPT	14	24
600 V/120 V with CPT	15	25
208 V/120 V with CPT	18	28
240 V/120 V with CPT and SP	53	63
480 V/120 V with CPT and SP	54	64
600 V/120 V with CPT and SP	55	65
208 V/120 V with CPT and SP	58	68
240 V/24 V with CPT ¹	A3	B3
480 V/24 V with CPT ¹	A4	B4
600 V/24 V with CPT ¹	A5	B5
208 V/24 V with CPT ¹	A8	B8

Note: CPT includes 2 primary fuses and 1 secondary fuse.

¹24 V coils not available for NEMA size 3 and 4.

Step 3 (digits 10, 11) select protective device

Thermal-magnetic circuit breaker

NEMA size	200–208 V			240 V			480 V			600 V		
	Max. hp	CB rating (amps)	Code	Max. hp	CB rating (amps)	Code	Max. hp	CB rating (amps)	Code	Max. hp	CB rating (amps)	Code
0	2	15	TC	3	15	TC	5	15	TC	5	15	TC
	3	15	TC	-	-	-	-	-	-	-	-	-
1	-	-	-	-	-	-	-	-	-	7½	15	TC
	5	25	TE	5	25	TE	7½	25	TE	-	-	-
	-	-	-	-	-	-	-	-	-	10	25	TE
2	7½	40	TG	7½	40	TG	10	25	TE	10	20	TD
	-	-	-	-	-	-	15	40	TG	15	40	TG
	10	60	TJ	10	60	TJ	-	-	-	-	-	-
	-	-	-	-	-	-	-	-	-	20	40	TG
	-	-	-	15	60	TJ	20	60	TJ	-	-	-
3	-	-	-	-	-	-	25	60	TJ	25	60	TJ
	-	-	-	-	-	-	30	60	TJ	30	60	TJ
	15	100	TN	20	100	TN	-	-	-	-	-	-
	-	-	-	-	-	-	-	-	-	40	60	TJ
	20	100	TN	25	100	TN	40	100	TN	-	-	-
	-	-	-	-	-	-	50	100	TN	50	100	TN
4	25	125	TQ	30	125	TQ	-	-	-	-	-	-
	30	150	TR	-	-	-	60	150	TR	60	150	TR
	-	-	-	40	200	TT	-	-	-	-	-	-
	-	-	-	-	-	-	75	150	TR	75	150	TR
	40	200	TT	50	200	TT	-	-	-	-	-	-
-	-	-	-	-	-	100	200	TT	100	200	TT	

Enclosed combination magnetic starters

CR412 2-speed/1-winding, thermal magnetic circuit breaker

Ordering code configuration

Valid for NEMA sizes 0–4

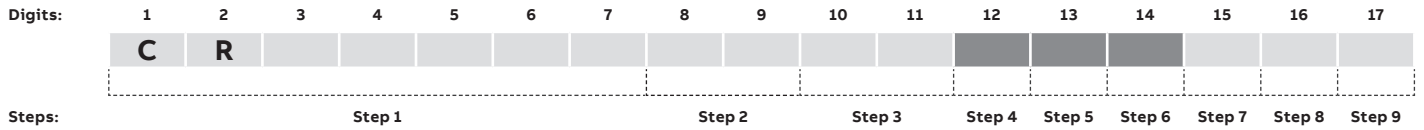

To configure the ordering code, use the tables below to fill in the digit boxes with the appropriate code.

Step 4 (digit 12) select overload relay

Overload relay	Code
Thermal bi-metallic ambient compensated (1 NC)	3
Thermal bi-metallic ambient compensated (1 NO–1 NC)	4
Solid state overload (1 NO–1 NC)	(#)

(#) Select code for solid state overload amp rating from standard or optional ranges table below.

2-speed solid state overload ranges

Code	0 and 1		2		NEMA size 3 and 4	
	Hi amp	Lo amp	Hi amp	Lo amp	Hi amp	Lo amp
c	0.4–0.85	0.4–0.85	6.5–13.5	6.5–13.5	17–35	17–35
D	0.8–1.7	0.4–0.85	13–27	6.5–13.5	35–70	17–35
E	0.8–1.7	0.8–1.7	13–27	13–27	35–70	35–70
F	1.6–3.4	0.4–0.85	25–50	6.5–13.5	65–135	17–35
G	1.6–3.4	0.8–1.7	25–50	13–27	65–135	35–70
H	1.6–3.4	1.6–3.4	25–50	25–50	65–135	65–135
U	3.2–6.8	0.8–1.7	–	–	–	–
K	3.2–6.8	1.6–3.4	–	–	–	–
L	3.2–6.8	3.2–6.8	–	–	–	–
M	6.5–13.5	1.6–3.4	–	–	–	–
V	6.5–13.5	3.2–6.8	–	–	–	–
W	6.5–13.5	6.5–13.5	–	–	–	–
R	13–27	3.2–6.8	–	–	–	–
S	13–27	6.5–13.5	–	–	–	–
T	13–27	13–27	–	–	–	–

Step 5 (digit 13) select auxiliary contacts

Auxiliary contacts (per contactor)	Code
None	A
1 NO	B
1 NC	C
1 NO–1 NC	D ²
2 NO	E ²
2 NC	F ²

²Not available on 2 speed – 1 winding sizes 0–1.

Step 6 (digit 14) select monitoring options

Device	Code
None	A
Phase failure relay with undervoltage protection (panel mounted) — 190–480 V (PFR with UV)	C
Phase failure relay with undervoltage protection (panel mounted) — 575 V (PFR with UV)	D
Phase failure relay — 208 V (PFR)	E ³
Phase failure relay — 240 V (PFR)	F ³
Phase failure relay — 480 V (PFR)	G ³
Phase failure relay — 575 V (PFR)	H ³
Elapsed time meter (120 V/60 Hz) wired across coil (ETM)	I ⁴
ETM + PFR with UV (190–480 V)	L ⁴
ETM + PFR with UV (575 V)	N ⁴
ETM + PFR (208 V)	P ^{3,4}
ETM + PFR (240 V)	Q ^{3,4}
ETM + PFR (480 V)	R ^{3,4}
ETM + PFR (575 V)	S ^{3,4}

³Available for type 1 enclosure only.

⁴Requires 120 V control circuit voltage or CPT with 120 V secondary.

Enclosed combination magnetic starters

CR412 2-speed/1-winding, thermal magnetic circuit breaker

Ordering code configuration

Valid for NEMA sizes 0–4

Digits:	1	2	3	4	5	6	7	8	9	10	11	12	13	14	15	16	17	
	C	R																
Steps:	Step 1			Step 2			Step 3		Step 4		Step 5		Step 6		Step 7		Step 8	Step 9

To configure the ordering code, use the tables below to fill in the digit boxes with the appropriate code.

Step 7 (digit 15) select pushbutton/selector switch

Pushbutton/selector switch — heavy duty	Code
None	A
Fast/slow/stop pushbutton	J
High/low/off pushbutton	K
High/low pushbutton and hand-off-auto (HOA) selector switch	L
Fast/slow pushbutton and hand-off-auto (HOA) selector switch	M
Hand-off-auto (HOA) and slow/fast selector switches	P
Hand-off-auto (HOA) and low/high selector switches	R
Slow-off-fast selector switch	T
Low-off-high selector switch	U
Fast-slow-off-auto selector switch	V
High-low-off-auto selector switch	W

Step 8 (digit 16) select pilot device

Pilot light (heavy duty CR104P style) type	Color — functionality	Code
None		A
LED lights	Red and amber across coils	2
	Red and green across coils	3
	Red and amber across coils and unwired green	5
Push-to-test lights	Red and amber across coils	S
	Red and green across coils	T
	Red and amber across coils and unwired green	Y

Step 9 (digit 17) select control options

Device	Code
None	A
1 relay, 2 NO-2 NC, 24/120 V coil — unwired	B ⁵
2 relays, 24/120 V coil — unwired	C ⁵
DIN rail — for customer use	D
12 point terminal strip — unwired (12 PT strip)	E
Space heater with NC contact	H ⁶
1 relay + 12 PT strip	J ⁵
2 relays + 12 PT strip	K ⁵
DIN rail + 12 PT strip + space heater	L ⁶
2 relays + 12 PT strip + space heater	M ^{5,6}
Time delay on relay, 24/120 V coil — unwired (TD)	N ⁵
Time delay off relay, 24/120 V coil — unwired (TD)	P ⁵
12 PT strip + TD ON	R ⁵
12 PT strip + TD OFF	S ⁵
12 PT strip + space heater + TD ON	T ^{5,6}
12 PT strip + space heater + TD OFF	U ^{5,6}

⁵Relay/timer coil voltage is equivalent to CPT secondary voltage. Requires minimum 100 extra VA CPT option.

⁶Maximum number of auxiliary contacts shall be reduced by 1.

General note:

On NEMA size 3 and 4 starters, if selecting factory installed and wired operator devices (pushbuttons, selector switches and/or pilot lights), then control circuit fusing, a control power transformer or 120 V separate sourced control is required when the protective device is rated greater than 100 amps.

Enclosed combination magnetic starters

CR413 2-speed/1-winding, disconnect switch

Ordering code configuration

Valid for NEMA sizes 0–4

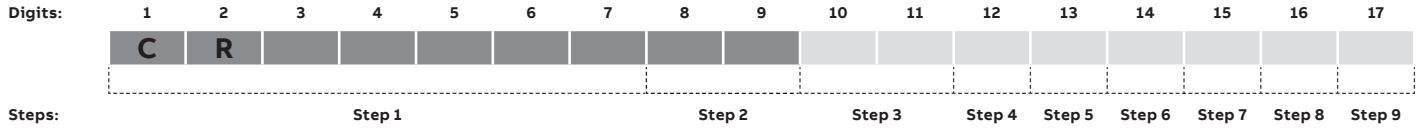

To configure the ordering code, use the tables below to fill in the digit boxes with the appropriate code.

Step 1 (digits 1–7) select NEMA size and enclosure

NEMA size	NEMA type 1	NEMA type 3R	NEMA type 12	NEMA type 4
	Standard enclosure	Standard enclosure	Standard enclosure	Standard enclosure
0	CR413B1	CR413B6	CR413B2	CR413B4
1	CR413C1	CR413C6	CR413C2	CR413C4
2	CR413D1	CR413D6	CR413D2	CR413D4
3	CR413E1	CR413E6	CR413E2	CR413E4
4	CR413F1	CR413F6	CR413F2	CR413F4

Note: All enclosures include external overload reset buttons. NEMA 4 enclosures are stainless steel.

Step 2 (digits 8, 9) select control voltage (no CPT and standard size CPT)

Control circuit voltage and CPT	Control fuses, no CPT		Standard size CPT
	No CPT	no CPT	
120 V with surge protector (SP)	01	F1	–
120 V	02	F2	–
240 V	03	F3	–
480 V	04	F4	–
600 V	05	F5	–
208 V	08	F8	–
24 V ¹	09	–	–
240 V/120 V with CPT	–	–	93
480 V/120 V with CPT	–	–	94
600 V/120 V with CPT	–	–	95
208 V/120 V with CPT	–	–	98
240 V/120 V with CPT and SP	–	–	33
480 V/120 V with CPT and SP	–	–	34
600 V/120 V with CPT and SP	–	–	35
208 V/120 V with CPT and SP	–	–	38
240 V/24 V with CPT ¹	–	–	S3
480 V/24 V with CPT ¹	–	–	S4
600 V/24 V with CPT ¹	–	–	S5
208 V/24 V with CPT ¹	–	–	S8

Note: CPT includes 2 primary fuses and 1 secondary fuse.
¹24 V coils not available for NEMA size 3 and 4.

Step 2 (digits 8, 9) select control voltage (extra capacity CPT + 100 VA and 200 VA)

Control circuit voltage and CPT	Standard size CPT + 100 VA	Standard size CPT + 200 VA
	120 V with surge protector (SP)	–
120 V	–	–
240 V	–	–
480 V	–	–
600 V	–	–
208 V	–	–
24 V ¹	–	–
240 V/120 V with CPT	13	23
480 V/120 V with CPT	14	24
600 V/120 V with CPT	15	25
208 V/120 V with CPT	18	28
240 V/120 V with CPT and SP	53	63
480 V/120 V with CPT and SP	54	64
600 V/120 V with CPT and SP	55	65
208 V/120 V with CPT and SP	58	68
240 V/24 V with CPT ¹	A3	B3
480 V/24 V with CPT ¹	A4	B4
600 V/24 V with CPT ¹	A5	B5
208 V/24 V with CPT ¹	A8	B8

Note: CPT includes 2 primary fuses and 1 secondary fuse.
¹24 V coils not available for NEMA size 3 and 4.

Please reference the [NEMA full voltage power devices catalog](#) for additional technical data, selection and installation guides, and dimensional drawings.

Enclosed combination magnetic starters

CR413 2-speed/1-winding, disconnect switch

Ordering code configuration

Valid for NEMA sizes 0–4

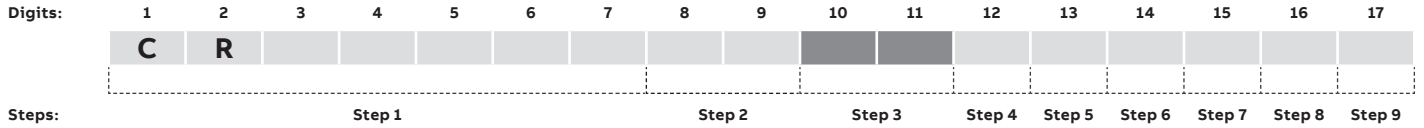

To configure the ordering code, use the tables below to fill in the digit boxes with the appropriate code.

Step 3 (digits 10, 11) select protective device

Disconnect without fuse clips

NEMA size	Code
All	1A

Disconnect with class H fuse clips — for use with non-time delay/single element class H fuses

NEMA size	200–208 V			230–240 V			460–480 V			575–600 V		
	Max. hp	Fuse clip (amps)	Code	Max. hp	Fuse clip (amps)	Code	Max. hp	Fuse clip (amps)	Code	Max. hp	Fuse clip (amps)	Code
0	3	30	HA	3	30	HA	5	30	H3	5	30	H3
1	–	–	–	–	–	–	7½	30	H3	10	30	H3
	7½	60	HB	7½	60	HB	10	60	H6	–	60	H6
2	–	–	–	–	–	–	15	60	H6	20	60	H6
	10	100	HC	15	100	HC	25	100	H1	25	100	H1
3	–	–	–	–	–	–	30	100	H1	30	100	H1
	25	200	HD	30	200	HD	50	200	H2	50	200	H2
4	–	–	–	–	–	–	60	200	H2	60	200	H2
	40	400	HE	50	400	HE	100	400	H4	100	400	H4

Disconnect with class R fuse clips — for use with time delay/dual element class RK1/RK5 fuses

NEMA size	200–208 V			230–240 V			460–480 V			575–600 V		
	Max. hp	Fuse clip (amps)	Code	Max. hp	Fuse clip (amps)	Code	Max. hp	Fuse clip (amps)	Code	Max. hp	Fuse clip (amps)	Code
0	3	30	RA	3	30	RA	5	30	R3	5	30	R3
1	5	30	RA	5	30	RA	10	30	R3	10	30	R3
	7½	60	RB	7½	60	RB	–	–	–	–	–	–
2	–	–	–	–	–	–	–	30	R3	15	30	R3
	10	60	RB	15	60	RB	25	60	R6	25	60	R6
3	–	–	–	–	–	–	–	60	R6	30	60	R6
	20	100	RC	25	100	RC	50	100	R1	50	100	R1
4	25	200	RD	30	200	RD	–	–	–	–	–	–
	–	–	–	–	–	–	–	100	R1	60	100	R1
	400	200	RD	50	200	RD	100	200	R2	100	200	R2

Please reference the [NEMA full voltage power devices catalog](#) for additional technical data, selection and installation guides, and dimensional drawings.

Enclosed combination magnetic starters

CR413 2-speed/1-winding, disconnect switch

Ordering code configuration

Valid for NEMA sizes 0-4

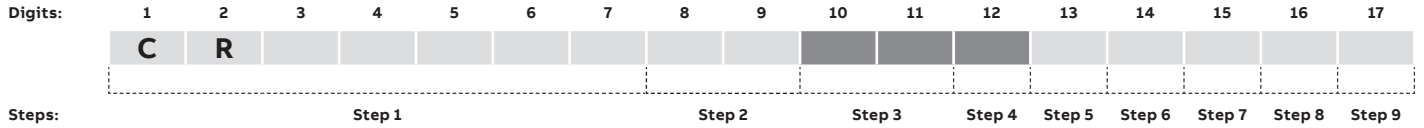

To configure the ordering code, use the tables below to fill in the digit boxes with the appropriate code.

Step 3 (digits 10, 11) select protective device (continued)

Disconnect with class J fuse clips — for use with time delay/dual element class J fuses

NEMA size	200-208 V			230-240 V			460-480 V			575-600 V		
	Max. hp	Fuse clip (amps)	Code	Max. hp	Fuse clip (amps)	Code	Max. hp	Fuse clip (amps)	Code	Max. hp	Fuse clip (amps)	Code
0	3	30	J3	3	30	J3	5	30	J3	5	30	J3
1	5	30	J3	5	30	J3	10	30	J3	10	30	J3
	7½	60	J6	7½	60	J6	-	-	-	-	-	-
2	-	-	-	-	-	-	-	30	J3	15	30	J3
	10	60	J6	15	60	J6	25	60	J6	25	60	J6
3	-	-	-	-	-	-	-	60	J6	30	60	J6
	20	100	J1	25	100	J1	50	100	J1	50	100	J1
4	25	200	J2	30	200	J2	-	-	-	-	-	-
	-	-	-	-	-	-	-	100	J1	60	100	J1
	40	200	J2	50	200	J2	100	200	J2	100	200	J2

Step 4 (digit 12) select overload relay

Overload relay	Code
Thermal bi-metallic ambient compensated (1 NC)	3
Thermal bi-metallic ambient compensated (1 NO-1 NC)	4
Solid state overload (1 NO-1 NC)	(#)

(#) Select code for solid state overload amp rating from standard or optional ranges table below.

2-speed solid state overload ranges

Code	0 and 1		2		NEMA size 3 and 4	
	Hi amp	Lo amp	Hi amp	Lo amp	Hi amp	Lo amp
C	0.4-0.85	0.4-0.85	6.5-13.5	6.5-13.5	17-35	17-35
D	0.8-1.7	0.4-0.85	13-27	6.5-13.5	35-70	17-35
E	0.8-1.7	0.8-1.7	13-27	13-27	35-70	35-70
F	1.6-3.4	0.4-0.85	25-50	6.5-13.5	65-135	17-35
G	1.6-3.4	0.8-1.7	25-50	13-27	65-135	35-70
H	1.6-3.4	1.6-3.4	25-50	25-50	65-135	65-135
U	3.2-6.8	0.8-1.7	-	-	-	-
K	3.2-6.8	1.6-3.4	-	-	-	-
L	3.2-6.8	3.2-6.8	-	-	-	-
M	6.5-13.5	1.6-3.4	-	-	-	-
V	6.5-13.5	3.2-6.8	-	-	-	-
W	6.5-13.5	6.5-13.5	-	-	-	-
R	13-27	3.2-6.8	-	-	-	-
S	13-27	6.5-13.5	-	-	-	-
T	13-27	13-27	-	-	-	-

Enclosed combination magnetic starters

CR413 2-speed/1-winding, disconnect switch

Ordering code configuration

Valid for NEMA sizes 0–4

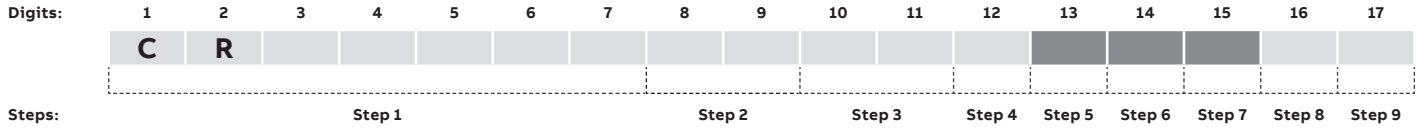

To configure the ordering code, use the tables below to fill in the digit boxes with the appropriate code.

Step 5 (digit 13) select auxiliary contacts

Auxiliary contacts (per contactor)	Code
None	A
1 NO	B
1 NC	C
1 NO–1 NC	D ²
2 NO	E ²
2 NC	F ²

²Not available on 2 speed — 1 winding sizes 0–1.

Step 6 (digit 14) select monitoring options

Device	Code
None	A
Phase failure relay with undervoltage protection (panel mounted) — 190–480 V (PFR with UV)	C
Phase failure relay with undervoltage protection (panel mounted) — 575 V (PFR with UV)	D
Phase failure relay — 208 V (PFR)	E ³
Phase failure relay — 240 V (PFR)	F ³
Phase failure relay — 480 V (PFR)	G ³
Phase failure relay — 575 V (PFR)	H ³
Elapsed time meter (120 V/60 Hz) wired across coil (ETM)	I ⁴
ETM + PFR with UV (190–480 V)	L ⁴
ETM + PFR with UV (575 V)	N ⁴
ETM + PFR (208 V)	P ^{3,4}
ETM + PFR (240 V)	Q ^{3,4}
ETM + PFR (480 V)	R ^{3,4}
ETM + PFR (575 V)	S ^{3,4}

³Available for type 1 enclosure only.

⁴Requires 120 V control circuit voltage or CPT with 120 V secondary.

Step 7 (digit 15) select pushbutton/selector switch

Pushbutton/selector switch — heavy duty	Code
None	A
Fast/slow/stop stop pushbutton	J
High/low/off pushbutton	K
High/low pushbutton and hand-off-auto (HOA) selector switch	L
Fast/slow pushbutton and hand-off-auto (HOA) selector switch	M
Hand-off-auto (HOA) and slow/fast selector switches	P
Hand-off-auto (HOA) and low/high selector switches	R
Slow-off-fast selector switch	T
Low-off-high selector switch	U
Fast-slow-off-auto selector switch	V
High-low-off-auto selector switch	W

Please reference the [NEMA full voltage power devices catalog](#) for additional technical data, selection and installation guides, and dimensional drawings.

Enclosed combination magnetic starters

CR413 2-speed/1-winding, disconnect switch

Ordering code configuration

Valid for NEMA sizes 0–4

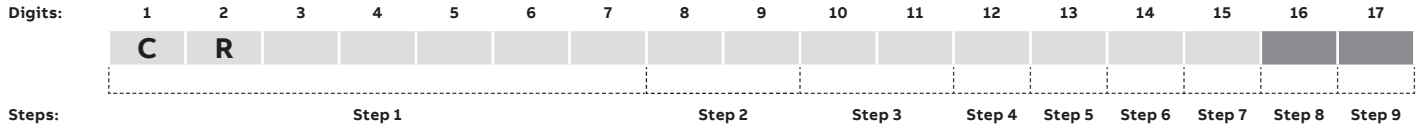

To configure the ordering code, use the tables below to fill in the digit boxes with the appropriate code.

Step 8 (digit 16) select pilot device

Pilot light (heavy duty CR104P style) type	Color — functionality	Code
None		A
	Red and amber across coils	2
LED lights	Red and green across coils	3
	Red and amber across coils and unwired green	5
	Red and amber across coils	S
Push-to-test lights	Red and green across coils	T
	Red and amber across coils and unwired green	Y

Step 9 (digit 17) select control options

Device	Code
None	A
1 relay, 2 NO-2 NC, 24/120 V coil — unwired	B ⁵
2 relays, 24/120 V coil — unwired	C ⁵
DIN rail — for customer use	D
12 point terminal strip — unwired (12 PT strip)	E
Space heater with NC contact	H ⁶
1 relay + 12 PT strip	J ⁵
2 relays + 12 PT strip	K ⁵
DIN rail + 12 PT strip + space heater	L ⁶
2 relays + 12 PT strip + space heater	M ^{5,6}
Time delay on relay, 24/120 V coil — unwired (TD)	N ⁵
Time delay off relay, 24/120 V coil — unwired (TD)	P ⁵
12 PT strip + TD ON	R ⁵
12 PT strip + TD OFF	S ⁵
12 PT strip + space heater + TD ON	T ^{5,6}
12 PT strip + space heater + TD OFF	U ^{5,6}

⁵Relay/timer coil voltage is equivalent to CPT secondary voltage. Requires minimum 100 extra VA CPT option.
⁶Maximum number of auxiliary contacts shall be reduced by 1.

General note:
 On NEMA size 3 and 4 starters, if selecting factory installed and wired operator devices (pushbuttons, selector switches and/or pilot lights), then control circuit fusing, a control power transformer or 120 V separate sourced control is required when the protective device is rated greater than 100 amps.

Please reference the [NEMA full voltage power devices catalog](#) for additional technical data, selection and installation guides, and dimensional drawings.

Enclosed combination magnetic starters

CR492 2-speed/1-winding, instantaneous trip circuit breaker

Ordering code configuration

Valid for NEMA sizes 0–4

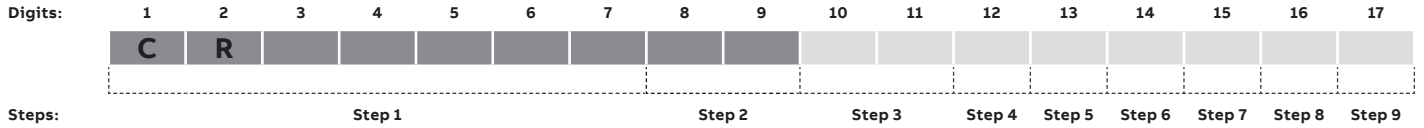

To configure the ordering code, use the tables below to fill in the digit boxes with the appropriate code.

Step 1 (digits 1–7) select NEMA size and enclosure

NEMA size	NEMA type 1	NEMA type 3R	NEMA type 12	NEMA type 4
	Standard enclosure	Standard enclosure	Standard enclosure	Standard enclosure
0	CR492B1	CR492B6	CR492B2	CR492B4
1	CR492C1	CR492C6	CR492C2	CR492C4
2	CR492D1	CR492D6	CR492D2	CR492D4
3	CR492E1	CR492E6	CR492E2	CR492E4
4	CR492F1	CR492F6	CR492F2	CR492F4

Note: All enclosures include external overload reset buttons. NEMA 4 enclosures are stainless steel.

Step 2 (digits 8, 9) select control voltage (no CPT and standard size CPT)

Control circuit voltage and CPT	No CPT	Control fuses, no CPT	Standard size CPT
120 V with surge protector (SP)	01	F1	–
120 V	02	F2	–
240 V	03	F3	–
480 V	04	F4	–
600 V	05	F5	–
208 V	08	F8	–
24 V ¹	09	–	–
240 V/120 V with CPT	–	–	93
480 V/120 V with CPT	–	–	94
600 V/120 V with CPT	–	–	95
208 V/120 V with CPT	–	–	98
240 V/120 V with CPT and SP	–	–	33
480 V/120 V with CPT and SP	–	–	34
600 V/120 V with CPT and SP	–	–	35
208 V/120 V with CPT and SP	–	–	38
240 V/24 V with CPT ¹	–	–	S3
480 V/24 V with CPT ¹	–	–	S4
600 V/24 V with CPT ¹	–	–	S5
208 V/24 V with CPT ¹	–	–	S8

Note: CPT includes 2 primary fuses and 1 secondary fuse.

¹24 V coils not available for NEMA size 3 and 4.

Please reference the [NEMA full voltage power devices catalog](#) for additional technical data, selection and installation guides, and dimensional drawings.

Enclosed combination magnetic starters

CR492 2-speed/1-winding, instantaneous trip circuit breaker

Ordering code configuration

Valid for NEMA sizes 0–4



To configure the ordering code, use the tables below to fill in the digit boxes with the appropriate code.

Step 2 (digits 8, 9) select control voltage (extra capacity CPT + 100 VA and 200 VA) (continued)

Control circuit voltage and CPT	Standard size CPT + 100 VA	Standard size CPT + 200 VA
120 V with surge protector (SP)	-	-
120 V	-	-
240 V	-	-
480 V	-	-
600 V	-	-
208 V	-	-
24 V ¹	-	-
240 V/120 V with CPT	13	23
480 V/120 V with CPT	14	24
600 V/120 V with CPT	15	25
208 V/120 V with CPT	18	28
240 V/120 V with CPT and SP	53	63
480 V/120 V with CPT and SP	54	64
600 V/120 V with CPT and SP	55	65
208 V/120 V with CPT and SP	58	68
240 V/24 V with CPT ¹	A3	B3
480 V/24 V with CPT ¹	A4	B4
600 V/24 V with CPT ¹	A5	B5
208 V/24 V with CPT ¹	A8	B8

Note: CPT includes 2 primary fuses and 1 secondary fuse.

¹24 V coils not available for NEMA size 3 and 4.

Step 3 (digits 10, 11) select protective device

Instantaneous trip circuit breaker

NEMA size	208 V			240 V			480 V			600 V		
	Max. hp	CB rating (amps)	Code	Max. hp	CB rating (amps)	Code	Max. hp	CB rating (amps)	Code	Max. hp	CB rating (amps)	Code
0	0.5	3	MA	0.5	3	MA	1	3	MA	1	3	MA
	1	7	MB	-	-	-	-	-	-	-	-	-
	-	-	-	-	-	-	3	7	MB	3	7	MB
	3	15	MC	1	7	MB	-	-	-	-	-	-
1	-	-	-	3	15	MC	5	15	MC	5	15	MC
	5	25	ME	5	25	ME	7½	25	ME	10	25	ME
	-	-	-	-	-	-	10	25	ME	-	-	-
2	7½	40	MG	7½	40	MG	-	-	-	-	-	-
	-	-	-	-	-	-	15	40	MG	15	40	MG
	10	60	MJ	10	60	MJ	-	-	-	-	-	-
	-	-	-	-	-	-	-	-	-	20	40	MG
3	-	-	-	15	60	MJ	20	60	MJ	-	-	-
	-	-	-	-	-	-	25	60	MJ	25	60	MJ
	-	-	-	-	-	-	30	60	MJ	30	60	MJ
	15	100	MN	20	100	MN	-	-	-	-	-	-
	-	-	-	-	-	-	-	-	-	40	60	MJ
4	20	100	MN	25	100	MN	40	100	MN	-	-	-
	25	100	MN	30	100	MN	50	100	MN	50	100	MN
	30	150	MR	-	-	-	60	100	MN	60	100	MN
	-	-	-	40	175	MS	-	-	-	-	-	-
4	-	-	-	-	-	-	75	150	MR	75	150	MR
	-	-	-	-	-	-	-	-	-	100	150	MR
	40	175	MS	50	175	MS	100	175	MS	-	-	-

Enclosed combination magnetic starters

CR492 2-speed/1-winding, instantaneous trip circuit breaker

Ordering code configuration

Valid for NEMA sizes 0-4

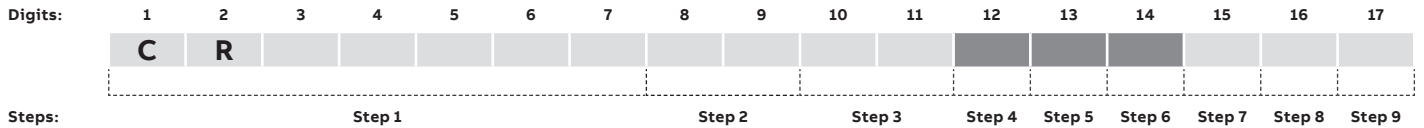

To configure the ordering code, use the tables below to fill in the digit boxes with the appropriate code.

Step 4 (digit 12) select overload relay

Overload relay	Code
Thermal bi-metallic ambient compensated (1 NC)	3
Thermal bi-metallic ambient compensated (1 NO-1 NC)	4
Solid state overload (1 NO-1 NC)	(#)

(#) Select code for solid state overload amp rating from ranges table below.

2-speed solid state overload ranges

Code	0 and 1		2		NEMA size 3 and 4	
	Hi Amp	Lo amp	Hi amp	Lo amp	Hi amp	Lo amp
c	0.4-0.85	0.4-0.85	6.5-13.5	6.5-13.5	17-35	17-35
D	0.8-1.7	0.4-0.85	13-27	6.5-13.5	35-70	17-35
E	0.8-1.7	0.8-1.7	13-27	13-27	35-70	35-70
F	1.6-3.4	0.4-0.85	25-50	6.5-13.5	65-135	17-35
G	1.6-3.4	0.8-1.7	25-50	13-27	65-135	35-70
H	1.6-3.4	1.6-3.4	25-50	25-50	65-135	65-135
U	3.2-6.8	0.8-1.7	-	-	-	-
K	3.2-6.8	1.6-3.4	-	-	-	-
L	3.2-6.8	3.2-6.8	-	-	-	-
M	6.5-13.5	1.6-3.4	-	-	-	-
V	6.5-13.5	3.2-6.8	-	-	-	-
W	6.5-13.5	6.5-13.5	-	-	-	-
R	13-27	3.2-6.8	-	-	-	-
S	13-27	6.5-13.5	-	-	-	-
T	13-27	13-27	-	-	-	-

Step 5 (digit 13) select auxiliary contacts

Auxiliary contacts (per contactor)	Code
None	A
1 NO	B
1 NC	C
1 NO-1 NC	D ²
2 NO	E ²
2 NC	F ²

²Not available on 2 speed - 1 winding sizes 0-1.

Step 6 (digit 14) select monitoring options

Device	Code
None	A
Phase failure relay with undervoltage protection (panel mounted) — 190-480 V (PFR with UV)	C
Phase failure relay with undervoltage protection (panel mounted) — 575 V (PFR with UV)	D
Phase failure relay — 208 V (PFR)	E ³
Phase failure relay — 240 V (PFR)	F ³
Phase failure relay — 480 V (PFR)	G ³
Phase failure relay — 575 V (PFR)	H ³
Elapsed time meter (120 V/60 Hz) wired across coil (ETM)	I ⁴
ETM + PFR with UV (190-480 V)	L ⁴
ETM + PFR with UV (575 V)	N ⁴
ETM + PFR (208 V)	p ^{3,4}
ETM + PFR (240 V)	Q ^{3,4}
ETM + PFR (480 V)	R ^{3,4}
ETM + PFR (575 V)	S ^{3,4}

³Available for type 1 enclosure only.

⁴Requires 120 V control circuit voltage or CPT with 120 V secondary.

Enclosed combination magnetic starters

CR492 2-speed/1-winding, instantaneous trip circuit breaker

Ordering code configuration

Valid for NEMA sizes 0–4

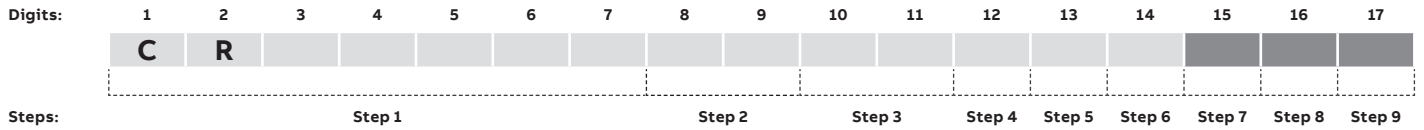

To configure the ordering code, use the tables below to fill in the digit boxes with the appropriate code.

Step 7 (digit 15) select pushbutton/selector switch

Pushbutton/selector switch — heavy duty	Code
None	A
Fast/slow/stop pushbutton	J
High/low/off pushbutton	K
High/low pushbutton and hand-off-auto (HOA) selector switch	L
Fast/slow pushbutton and hand-off-auto (HOA) selector switch	M
Hand-off-auto (HOA) and slow/fast selector switches	P
Hand-off-auto (HOA) and low/high selector switches	R
Slow-off-fast selector switch	T
Low-off-high selector switch	U
Fast-slow-off-auto selector switch	V
High-low-off-auto selector switch	W

Step 8 (digit 16) select pilot device

Pilot light (heavy duty CR104P style) type	Color — functionality	Code
None		A
LED lights	Red and amber across coils	2
	Red and green across coils	3
	Red and amber across coils and unwired green	5
Push-to-test lights	Red and amber across coils	S
	Red and green across coils	T
	Red and amber across coils and unwired green	Y

Step 9 (digit 17) select control options

Device	Code
None	A
1 relay, 2 NO-2 NC, 24/120 V coil — unwired	B ⁵
2 relays, 24/120 V coil — unwired	C ⁵
DIN rail — for customer use	D
12 point terminal strip — unwired (12 PT strip)	E
Space heater with NC contact	H ⁶
1 relay + 12 PT strip	J ⁵
2 relays + 12 PT strip	K ⁵
DIN rail + 12 PT strip + space heater	L ⁶
2 relays + 12 PT strip + space heater	M ^{5,6}
Time delay on relay, 24/120 V coil — unwired (TD)	N ⁵
Time delay off relay, 24/120 V coil — unwired (TD)	P ⁵
12 PT strip + TD ON	R ⁵
12 PT strip + TD OFF	S ⁵
12 PT strip + space heater + TD ON	T ^{5,6}
12 PT strip + space heater + TD OFF	U ^{5,6}

⁵Relay/timer coil voltage is equivalent to CPT secondary voltage. Requires minimum 100 extra VA CPT option.

⁶Maximum number of auxiliary contacts shall be reduced by 1.

General note:

If selecting factory installed and wired operator devices (pushbuttons, selector switches and/or pilot lights), control circuit fusing, a control power transformer or 24 V/120 V separate sourced control is required, regardless of protective device rating.

Enclosed combination magnetic starters

CR414 2-speed/2-winding, thermal magnetic circuit breaker

Ordering code configuration

Valid for NEMA sizes 0–4

Digits:	1	2	3	4	5	6	7	8	9	10	11	12	13	14	15	16	17
	C	R															
Steps:	Step 1							Step 2		Step 3		Step 4	Step 5	Step 6	Step 7	Step 8	Step 9

To configure the ordering code, use the tables below to fill in the digit boxes with the appropriate code.

Step 1 (digits 1–7) select NEMA size and enclosure

NEMA size	NEMA type 1	NEMA type 3R	NEMA type 12	NEMA type 4
	Standard enclosure	Standard enclosure	Standard enclosure	Standard enclosure
0	CR414B1	CR414B6	CR414B2	CR414B4
1	CR414C1	CR414C6	CR414C2	CR414C4
2	CR414D1	CR414D6	CR414D2	CR414D4
3	CR414E1	CR414E6	CR414E2	CR414E4
4	CR414F1	CR414F6	CR414F2	CR414F4

Note: All enclosures include external overload reset buttons. NEMA 4 enclosures are stainless steel.

Step 2 (digits 8, 9) select control voltage (no CPT and standard size CPT)

Control circuit voltage and CPT	No CPT	Control fuses, no CPT	Standard size CPT
120 V with surge protector (SP)	01	F1	–
120 V	02	F2	–
240 V	03	F3	–
480 V	04	F4	–
600 V	05	F5	–
208 V	08	F8	–
24 V ¹	09	–	–
240 V/120 V with CPT	–	–	93
480 V/120 V with CPT	–	–	94
600 V/120 V with CPT	–	–	95
208 V/120 V with CPT	–	–	98
240 V/120 V with CPT and SP	–	–	33
480 V/120 V with CPT and SP	–	–	34
600 V/120 V with CPT and SP	–	–	35
208 V/120 V with CPT and SP	–	–	38
240 V/24 V with CPT ¹	–	–	S3
480 V/24 V with CPT ¹	–	–	S4
600 V/24 V with CPT ¹	–	–	S5
208 V/24 V with CPT ¹	–	–	S8

Note: CPT includes 2 primary fuses and 1 secondary fuse.

¹24 V coils not available for NEMA size 3 and 4.

Please reference the [NEMA full voltage power devices catalog](#) for additional technical data, selection and installation guides, and dimensional drawings.

Enclosed combination magnetic starters

CR414 2-speed/2-winding, thermal magnetic circuit breaker

Ordering code configuration

Valid for NEMA sizes 0–4

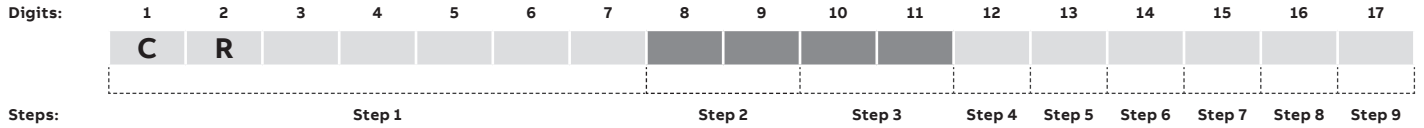

To configure the ordering code, use the tables below to fill in the digit boxes with the appropriate code.

Step 2 (digits 8, 9) select control voltage (extra capacity CPT + 100 VA and 200 VA) (continued)

Control circuit voltage and CPT	Standard size CPT + 100 VA	Standard size CPT + 200 VA
120 V with surge protector (SP)	-	-
120 V	-	-
240 V	-	-
480 V	-	-
600 V	-	-
208 V	-	-
24 V ¹	-	-
240 V/120 V with CPT	13	23
480 V/120 V with CPT	14	24
600 V/120 V with CPT	15	25
208 V/120 V with CPT	18	28
240 V/120 V with CPT and SP	53	63
480 V/120 V with CPT and SP	54	64
600 V/120 V with CPT and SP	55	65
208 V/120 V with CPT and SP	58	68
240 V/24 V with CPT ¹	A3	B3
480 V/24 V with CPT ¹	A4	B4
600 V/24 V with CPT ¹	A5	B5
208 V/24 V with CPT ¹	A8	B8

Note: CPT includes 2 primary fuses and 1 secondary fuse.

¹24 V coils not available for NEMA size 3 and 4.

Step 3 (digits 10, 11) select protective device

Thermal-magnetic circuit breaker

NEMA size	200–208 V			240 V			480 V			600 V		
	Max. hp	CB rating (amps)	Code	Max. hp	CB rating (amps)	Code	Max. hp	CB rating (amps)	Code	Max. hp	CB rating (amps)	Code
0	2	15	TC	3	15	TC	5	15	TC	5	15	TC
	3	15	TC	-	-	-	-	-	-	-	-	-
1	-	-	-	-	-	-	-	-	-	7½	15	TC
	5	25	TE	5	25	TE	7½	25	TE	-	-	-
	-	-	-	-	-	-	-	-	-	10	25	TE
2	7½	40	TG	7½	40	TG	10	25	TE	10	20	TD
	-	-	-	-	-	-	15	40	TG	15	40	TG
	10	60	TJ	10	60	TJ	-	-	-	-	-	-
	-	-	-	-	-	-	-	-	-	20	40	TG
3	-	-	-	15	60	TJ	20	60	TJ	-	-	-
	-	-	-	-	-	-	25	60	TJ	25	60	TJ
	-	-	-	-	-	-	30	60	TJ	30	60	TJ
	15	100	TN	20	100	TN	-	-	-	-	-	-
	-	-	-	-	-	-	-	-	-	40	60	TJ
4	20	100	TN	25	100	TN	40	100	TN	-	-	-
	-	-	-	-	-	-	50	100	TN	50	100	TN
	25	125	TQ	30	125	TQ	-	-	-	-	-	-
	30	150	TR	-	-	-	60	150	TR	60	150	TR
	-	-	-	40	200	TT	-	-	-	-	-	-
4	-	-	-	-	-	-	75	150	TR	75	150	TR
	40	200	TT	50	200	TT	-	-	-	-	-	-
	-	-	-	-	-	-	100	200	TT	100	200	TT

Enclosed combination magnetic starters

CR414 2-speed/2-winding, thermal magnetic circuit breaker

Ordering code configuration

Valid for NEMA sizes 0–4

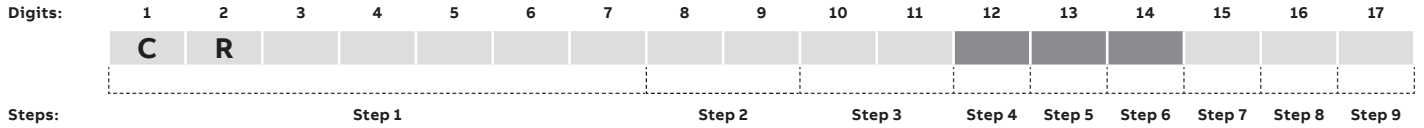

To configure the ordering code, use the tables below to fill in the digit boxes with the appropriate code.

Step 4 (digit 12) select overload relay

Overload relay	Code
Thermal bi-metallic ambient compensated (1 NC)	3
Thermal bi-metallic ambient compensated (1 NO–1 NC)	4
Solid state overload (1 NO–1 NC)	(#)

(#) Select code for solid state overload amp rating from ranges table below.

2-speed solid state overload ranges

Code	0 and 1		2		NEMA size 3 and 4	
	Hi amp	Lo amp	Hi amp	Lo amp	Hi amp	Lo amp
C	0.4–0.85	0.4–0.85	6.5–13.5	6.5–13.5	17–35	17–35
D	0.8–1.7	0.4–0.85	13–27	6.5–13.5	35–70	17–35
E	0.8–1.7	0.8–1.7	13–27	13–27	35–70	35–70
F	1.6–3.4	0.4–0.85	25–50	6.5–13.5	65–135	17–35
G	1.6–3.4	0.8–1.7	25–50	13–27	65–135	35–70
H	1.6–3.4	1.6–3.4	25–50	25–50	65–135	65–135
U	3.2–6.8	0.8–1.7	–	–	–	–
K	3.2–6.8	1.6–3.4	–	–	–	–
L	3.2–6.8	3.2–6.8	–	–	–	–
M	6.5–13.5	1.6–3.4	–	–	–	–
V	6.5–13.5	3.2–6.8	–	–	–	–
W	6.5–13.5	6.5–13.5	–	–	–	–
R	13–27	3.2–6.8	–	–	–	–
S	13–27	6.5–13.5	–	–	–	–
T	13–27	13–27	–	–	–	–

Step 5 (digit 13) select auxiliary contacts

Auxiliary contacts (per contactor)	Code
None	A
1 NO	B
1 NC	C
1 NO–1 NC	D ²
2 NO	E ²
2 NC	F ²

²Not available on 2 speed — 2 winding sizes 0-1.

Step 6 (digit 14) select monitoring options

Device	Code
None	A
Phase failure relay with undervoltage protection (panel mounted) — 190–480 V (PFR with UV)	C
Phase failure relay with undervoltage protection (panel mounted) — 575 V (PFR with UV)	D
Phase failure relay — 208 V (PFR)	E ³
Phase failure relay — 240 V (PFR)	F ³
Phase failure relay — 480 V (PFR)	G ³
Phase failure relay — 575 V (PFR)	H ³
Elapsed time meter (120 V/60 Hz) wired across coil (ETM)	I ⁴
ETM + PFR with UV (190–480 V)	L ⁴
ETM + PFR with UV (575 V)	N ⁴
ETM + PFR (208 V)	P ^{3,4}
ETM + PFR (240 V)	Q ^{3,4}
ETM + PFR (480 V)	R ^{3,4}
ETM + PFR (575 V)	S ^{3,4}

³Available for type 1 enclosure only.

⁴Requires 120 V control circuit voltage or CPT with 120 V secondary.

Enclosed combination magnetic starters

CR414 2-speed/2-winding, thermal magnetic circuit breaker

Ordering code configuration

Valid for NEMA sizes 0–4

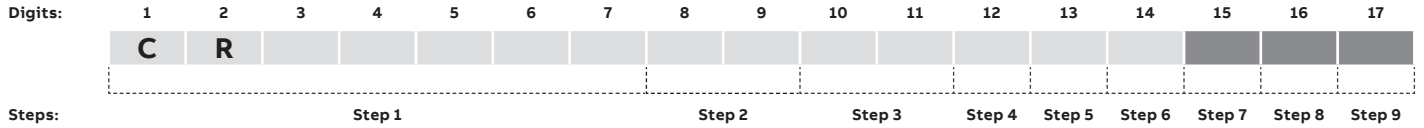

To configure the ordering code, use the tables below to fill in the digit boxes with the appropriate code.

Step 7 (digit 15) select pushbutton/selector switch

Pushbutton/selector switch — heavy duty	Code
None	A
Fast/slow/stop pushbutton	J
High/low/off pushbutton	K
High/low pushbutton and hand-off-auto (HOA) selector switch	L
Fast/slow pushbutton and hand-off-auto (HOA) selector switch	M
Hand-off-auto (HOA) and slow/fast selector switches	P
Hand-off-auto (HOA) and low/high selector switches	R
Slow-off-fast selector switch	T
Low-off-high selector switch	U
Fast-slow-off-auto selector switch	V
High-low-off-auto selector switch	W

Step 8 (digit 16) select pilot device

Pilot light (heavy duty CR104P style) type	Color — functionality	Code
None		A
LED lights	Red and amber across coils	2
	Red and green across coils	3
	Red and amber across coils and unwired green	5
Push-to-test lights	Red and amber across coils	S
	Red and green across coils	T
	Red and amber across coils and unwired green	Y

Step 9 (digit 17) select control options

Device	Code
None	A
1 relay, 2 NO–2 NC, 24/120 V coil — unwired	B ⁵
2 relays, 24/120 V coil — unwired	C ⁵
DIN rail — for customer use	D
12 point terminal strip — unwired (12 PT strip)	E
Space heater with NC contact	H ⁶
1 relay + 12 PT strip	J ⁵
2 relays + 12 PT strip	K ⁵
DIN rail + 12 PT strip + space heater	L ⁶
2 relays + 12 PT strip + space heater	M ^{5,6}
Time delay on relay, 24/120 V coil — unwired (TD)	N ⁵
Time delay off relay, 24/120 V coil — unwired (TD)	P ⁵
12 PT strip + TD ON	R ⁵
12 PT strip + TD OFF	S ⁵
12 PT strip + space heater + TD ON	T ^{5,6}
12 PT strip + space heater + TD OFF	U ^{5,6}

⁵Relay/timer coil voltage is equivalent to CPT secondary voltage. Requires minimum 100 extra VA CPT option.

⁶Maximum number of auxiliary contacts shall be reduced by 1.

General note:

On NEMA size 3 and 4 starters, if selecting factory installed and wired operator devices (pushbuttons, selector switches and/or pilot lights), then control circuit fusing, a control power transformer or 120 V separate sourced control is required when the protective device is rated greater than 100 amps.

Enclosed combination magnetic starters

CR415 2-speed/2-winding, disconnect switch

Ordering code configuration

Valid for NEMA sizes 0–4

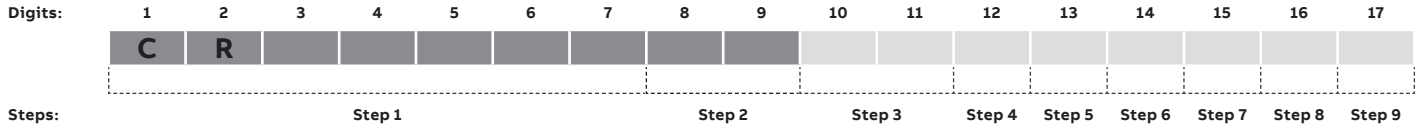

To configure the ordering code, use the tables below to fill in the digit boxes with the appropriate code.

Step 1 (digits 1–7) select NEMA size and enclosure

NEMA size	NEMA type 1	NEMA type 3R	NEMA type 12	NEMA type 4
	Standard enclosure	Standard enclosure	Standard enclosure	Standard enclosure
0	CR415B1	CR415B6	CR415B2	CR415B4
1	CR415C1	CR415C6	CR415C2	CR415C4
2	CR415D1	CR415D6	CR415D2	CR415D4
3	CR415E1	CR415E6	CR415E2	CR415E4
4	CR415F1	CR415F6	CR415F2	CR415F4

Note: All enclosures include external overload reset buttons. NEMA 4 enclosures are stainless steel.

Step 2 (digits 8, 9) select control voltage (no CPT and standard size CPT)

Control circuit voltage and CPT	No CPT	Control fuses, no CPT	Standard size CPT
120 V with surge protector (SP)	01	F1	–
120 V	02	F2	–
240 V	03	F3	–
480 V	04	F4	–
600 V	05	F5	–
208 V	08	F8	–
24 V ¹	09	–	–
240 V/120 V with CPT	–	–	93
480 V/120 V with CPT	–	–	94
600 V/120 V with CPT	–	–	95
208 V/120 V with CPT	–	–	98
240 V/120 V with CPT and SP	–	–	33
480 V/120 V with CPT and SP	–	–	34
600 V/120 V with CPT and SP	–	–	35
208 V/120 V with CPT and SP	–	–	38
240 V/24 V with CPT ¹	–	–	S3
480 V/24 V with CPT ¹	–	–	S4
600 V/24 V with CPT ¹	–	–	S5
208 V/24 V with CPT ¹	–	–	S8

Note: CPT includes 2 primary fuses and 1 secondary fuse.

¹24 V coils not available for NEMA size 3 and 4.

Please reference the [NEMA full voltage power devices catalog](#) for additional technical data, selection and installation guides, and dimensional drawings.

Enclosed combination magnetic starters

CR415 2-speed/2-winding, disconnect switch

Ordering code configuration

Valid for NEMA sizes 0–4

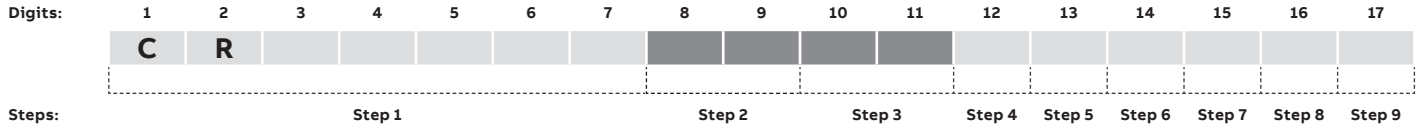

To configure the ordering code, use the tables below to fill in the digit boxes with the appropriate code.

Step 2 (digits 8, 9) select control voltage (extra capacity CPT + 100 VA and 200 VA) (continued)

Control circuit voltage and CPT	Standard size CPT + 100 VA	Standard size CPT + 200 VA
120 V with surge protector (SP)	–	–
120 V	–	–
240 V	–	–
480 V	–	–
600 V	–	–
208 V	–	–
24 V ¹	–	–
240 V/120 V with CPT	13	23
480 V/120 V with CPT	14	24
600 V/120 V with CPT	15	25
208 V/120 V with CPT	18	28
240 V/120 V with CPT and SP	53	63
480 V/120 V with CPT and SP	54	64
600 V/120 V with CPT and SP	55	65
208 V/120 V with CPT and SP	58	68
240 V/24 V with CPT ¹	A3	B3
480 V/24 V with CPT ¹	A4	B4
600 V/24 V with CPT ¹	A5	B5
208 V/24 V with CPT ¹	A8	B8

Note: CPT includes 2 primary fuses and 1 secondary fuse.
¹24 V coils not available for NEMA size 3 and 4.

Step 3 (digits 10, 11) select protective device

Disconnect without fuse clips

NEMA size	Code
All	1A

Disconnect with class H fuse clips — for use with non-time delay/single element class H fuses

NEMA size	200–208 V			230–240 V			460–480 V			575–600 V		
	Max. hp	Fuse clip (amps)	Code	Max. hp	Fuse clip (amps)	Code	Max. hp	Fuse clip (amps)	Code	Max. hp	Fuse clip (amps)	Code
0	3	30	HA	3	30	HA	5	30	H3	5	30	H3
1	–	–	–	–	–	–	7½	30	H3	10	30	H3
	7½	60	HB	7½	60	HB	10	60	H6	–	60	H6
2	–	–	–	–	–	–	15	60	H6	20	60	H6
	10	100	HC	15	100	HC	25	100	H1	25	100	H1
3	–	–	–	–	–	–	30	100	H1	30	100	H1
	25	200	HD	30	200	HD	50	200	H2	50	200	H2
4	–	–	–	–	–	–	60	200	H2	60	200	H2
	40	400	HE	50	400	HE	100	400	H4	100	400	H4

Enclosed combination magnetic starters

CR415 2-speed/2-winding, disconnect switch

Ordering code configuration

Valid for NEMA sizes 0-4

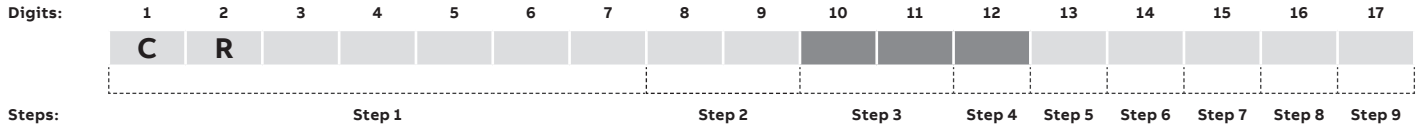

To configure the ordering code, use the tables below to fill in the digit boxes with the appropriate code.

Step 3 (digits 10, 11) select protective device (continued)

Disconnect with class R fuse clips — for use with time delay/dual element class RK1/RK5 fuses

NEMA size	200-208 V			230-240 V			460-480 V			575-600 V		
	Max. hp	Fuse clip (amps)	Code	Max. hp	Fuse clip (amps)	Code	Max. hp	Fuse clip (amps)	Code	Max. hp	Fuse clip (amps)	Code
0	3	30	RA	3	30	RA	5	30	R3	5	30	R3
1	5	30	RA	5	30	RA	10	30	R3	10	30	R3
	7½	60	RB	7½	60	RB	-	-	-	-	-	-
2	-	-	-	-	-	-	-	30	R3	15	30	R3
	10	60	RB	15	60	RB	25	60	R6	25	60	R6
3	-	-	-	-	-	-	-	60	R6	30	60	R6
	20	100	RC	25	100	RC	50	100	R1	50	100	R1
	25	200	RD	30	200	RD	-	-	-	-	-	-
4	-	-	-	-	-	-	-	100	R1	60	100	R1
	400	200	RD	50	200	RD	100	200	R2	100	200	R2

Disconnect with class J fuse clips — for use with time delay/dual element class J fuses

NEMA size	200-208 V			230-240 V			460-480 V			575-600 V		
	Max. hp	Fuse clip (amps)	Code	Max. hp	Fuse clip (amps)	Code	Max. hp	Fuse clip (amps)	Code	Max. hp	Fuse clip (amps)	Code
0	3	30	J3	3	30	J3	5	30	J3	5	30	J3
1	5	30	J3	5	30	J3	10	30	J3	10	30	J3
	7½	60	J6	7½	60	J6	-	-	-	-	-	-
2	-	-	-	-	-	-	-	30	J3	15	30	J3
	10	60	J6	15	60	J6	25	60	J6	25	60	J6
3	-	-	-	-	-	-	-	60	J6	30	60	J6
	20	100	J1	25	100	J1	50	100	J1	50	100	J1
4	25	200	J2	30	200	J2	-	-	-	-	-	-
	-	-	-	-	-	-	-	100	J1	60	100	J1
	40	200	J2	50	200	J2	100	200	J2	100	200	J2

Step 4 (digit 12) select overload relay

Overload relay	Code
Thermal bi-metallic ambient Compensated (1 NC)	3
Thermal bi-metallic ambient compensated (1 NO-1 NC)	4
Solid state overload (1 NO-1 NC)	(#)

(#) Select code for solid state overload amp rating from ranges table on following page.

Please reference the [NEMA full voltage power devices catalog](#) for additional technical data, selection and installation guides, and dimensional drawings.

Enclosed combination magnetic starters

CR415 2-speed/2-winding, disconnect switch

Ordering code configuration

Valid for NEMA sizes 0–4

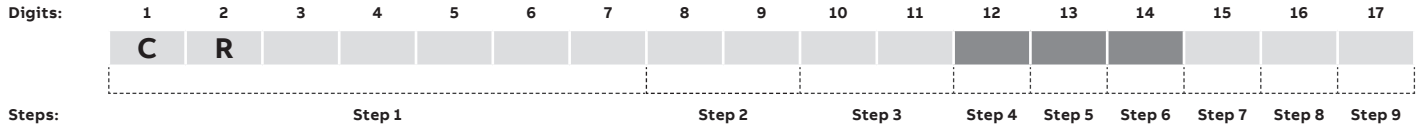

To configure the ordering code, use the tables below to fill in the digit boxes with the appropriate code.

Step 4 (digit 12) 2-speed solid state overload ranges (continued)

Code	0 and 1		2		NEMA size 3 and 4	
	Hi amp	Lo amp	Hi amp	Lo amp	Hi amp	Lo amp
C	0.4–0.85	0.4–0.85	6.5–13.5	6.5–13.5	17–35	17–35
D	0.8–1.7	0.4–0.85	13–27	6.5–13.5	35–70	17–35
E	0.8–1.7	0.8–1.7	13–27	13–27	35–70	35–70
F	1.6–3.4	0.4–0.85	25–50	6.5–13.5	65–135	17–35
G	1.6–3.4	0.8–1.7	25–50	13–27	65–135	35–70
H	1.6–3.4	1.6–3.4	25–50	25–50	65–135	65–135
U	3.2–6.8	0.8–1.7	-	-	-	-
K	3.2–6.8	1.6–3.4	-	-	-	-
L	3.2–6.8	3.2–6.8	-	-	-	-
M	6.5–13.5	1.6–3.4	-	-	-	-
V	6.5–13.5	3.2–6.8	-	-	-	-
W	6.5–13.5	6.5–13.5	-	-	-	-
R	13–27	3.2–6.8	-	-	-	-
S	13–27	6.5–13.5	-	-	-	-
T	13–27	13–27	-	-	-	-

Step 5 (digit 13) select auxiliary contacts

Auxiliary contacts (per contactor)	Code
None	A
1 NO	B
1 NC	C
1 NO–1 NC	D ²
2 NO	E ²
2 NC	F ²

²Not available on 2 speed — 2 winding sizes 0–1.

Step 6 (digit 14) select monitoring options

Device	Code
None	A
Phase failure relay with undervoltage protection (panel mounted) — 190–480 V (PFR with UV)	C
Phase failure relay with undervoltage protection (panel mounted) — 575 V (PFR with UV)	D
Phase failure relay — 208 V (PFR)	E ³
Phase failure relay — 240 V (PFR)	F ³
Phase failure relay — 480 V (PFR)	G ³
Phase failure relay — 575 V (PFR)	H ³
Elapsed time meter (120 V/60 Hz) wired across coil (ETM)	I ⁴
ETM + PFR with UV (190–480 V)	L ⁴
ETM + PFR with UV (575 V)	N ⁴
ETM + PFR (208 V)	P ^{3,4}
ETM + PFR (240 V)	Q ^{3,4}
ETM + PFR (480 V)	R ^{3,4}
ETM + PFR (575 V)	S ^{3,4}

³Available for type 1 enclosure only.

⁴Requires 120 V control circuit voltage or CPT with 120 V secondary.

Enclosed combination magnetic starters

CR494 2-speed/2-winding, instantaneous trip circuit breaker

Ordering code configuration

Valid for NEMA sizes 0–4

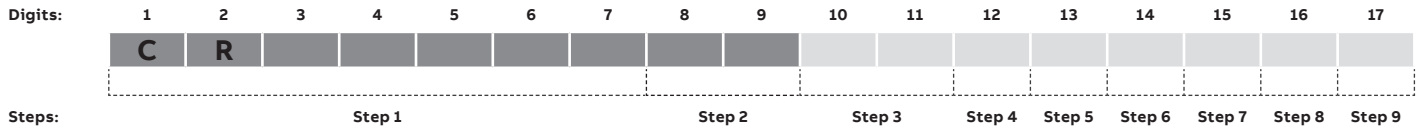

To configure the ordering code, use the tables below to fill in the digit boxes with the appropriate code.

Step 1 (digits 1–7) select NEMA size and enclosure

NEMA size	NEMA type 1	NEMA type 3R	NEMA type 12	NEMA type 4
	Standard enclosure	Standard enclosure	Standard enclosure	Standard enclosure
0	CR494B1	CR494B6	CR494B2	CR494B4
1	CR494C1	CR494C6	CR494C2	CR494C4
2	CR494D1	CR494D6	CR494D2	CR494D4
3	CR494E1	CR494E6	CR494E2	CR494E4
4	CR494F1	CR494F6	CR494F2	CR494F4

Note: All enclosures include external overload reset buttons. NEMA 4 enclosures are stainless steel.

Step 2 (digits 8, 9) select control voltage (no CPT and standard size CPT)

Control circuit voltage and CPT	No CPT	Control fuses, no CPT	Standard size CPT
120 V with surge protector (SP)	01	F1	–
120 V	02	F2	–
240 V	03	F3	–
480 V	04	F4	–
600 V	05	F5	–
208 V	08	F8	–
24 V ¹	09	–	–
240 V/120 V with CPT	–	–	93
480 V/120 V with CPT	–	–	94
600 V/120 V with CPT	–	–	95
208 V/120 V with CPT	–	–	98
240 V/120 V with CPT and SP	–	–	33
480 V/120 V with CPT and SP	–	–	34
600 V/120 V with CPT and SP	–	–	35
208 V/120 V with CPT and SP	–	–	38
240 V/24 V with CPT ¹	–	–	S3
480 V/24 V with CPT ¹	–	–	S4
600 V/24 V with CPT ¹	–	–	S5
208 V/24 V with CPT ¹	–	–	S8

Note: CPT includes 2 primary fuses and 1 secondary fuse.

¹24 V coils not available for NEMA size 3 and 4.

Please reference the [NEMA full voltage power devices catalog](#) for additional technical data, selection and installation guides, and dimensional drawings.

Enclosed combination magnetic starters

CR494 2-speed/2-winding, instantaneous trip circuit breaker

Ordering code configuration

Valid for NEMA sizes 0–4



To configure the ordering code, use the tables below to fill in the digit boxes with the appropriate code.

Step 2 (digits 8, 9) select control voltage (extra capacity CPT + 100 VA and 200 VA) (continued)

Control circuit voltage and CPT	Standard size CPT + 100 VA	Standard size CPT + 200 VA
120 V with surge protector (SP)	–	–
120 V	–	–
240 V	–	–
480 V	–	–
600 V	–	–
208 V	–	–
24 V ¹	–	–
240 V/120 V with CPT	13	23
480 V/120 V with CPT	14	24
600 V/120 V with CPT	15	25
208 V/120 V with CPT	18	28
240 V/120 V with CPT and SP	53	63
480 V/120 V with CPT and SP	54	64
600 V/120 V with CPT and SP	55	65
208 V/120 V with CPT and SP	58	68
240 V/24 V with CPT ¹	A3	B3
480 V/24 V with CPT ¹	A4	B4
600 V/24 V with CPT ¹	A5	B5
208 V/24 V with CPT ¹	A8	B8

Note: CPT includes 2 primary fuses and 1 secondary fuse.

¹24 V coils not available for NEMA size 3 and 4.

Step 3 (digits 10, 11) select protective device

Instantaneous trip circuit breaker

NEMA size	208 V			240 V			480 V			600 V		
	Max. hp	CB rating (amps)	Code	Max. hp	CB rating (amps)	Code	Max. hp	CB rating (amps)	Code	Max. hp	CB rating (amps)	Code
0	0.5	3	MA	0.5	3	MA	1	3	MA	1	3	MA
	1	7	MB	–	–	–	–	–	–	–	–	–
	–	–	–	–	–	–	3	7	MB	3	7	MB
	3	15	MC	1	7	MB	–	–	–	–	–	–
1	–	–	–	3	15	MC	5	15	MC	5	15	MC
	5	25	ME	5	25	ME	7½	25	ME	10	25	ME
	–	–	–	–	–	–	10	25	ME	–	–	–
	7½	40	MG	7½	40	MG	–	–	–	–	–	–
2	–	–	–	–	–	–	15	40	MG	15	40	MG
	10	60	MJ	10	60	MJ	–	–	–	–	–	–
	–	–	–	–	–	–	–	–	–	–	–	–
	–	–	–	–	–	–	–	–	–	20	40	MG
	–	–	–	15	60	MJ	20	60	MJ	–	–	–
3	–	–	–	–	–	–	25	60	MJ	25	60	MJ
	–	–	–	–	–	–	30	60	MJ	30	60	MJ
	15	100	MN	20	100	MN	–	–	–	–	–	–
	–	–	–	–	–	–	–	–	–	40	60	MJ
4	20	100	MN	25	100	MN	40	100	MN	–	–	–
	25	100	MN	30	100	MN	50	100	MN	50	100	MN
	30	150	MR	–	–	–	60	100	MN	60	100	MN
	–	–	–	40	175	MS	–	–	–	–	–	–
	–	–	–	–	–	–	75	150	MR	75	150	MR
–	–	–	–	–	–	–	–	–	100	150	MR	
–	–	–	40	175	MS	100	175	MS	–	–	–	

Enclosed combination magnetic starters

CR494 2-speed/2-winding, instantaneous trip circuit breaker

Ordering code configuration

Valid for NEMA sizes 0–4

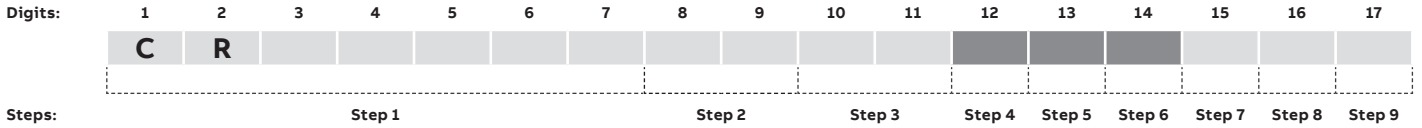

To configure the ordering code, use the tables below to fill in the digit boxes with the appropriate code.

Step 4 (digit 12) select overload relay

Overload relay	Code
Thermal bi-metallic ambient compensated (1 NC)	3
Thermal bi-metallic ambient compensated (1 NO–1 NC)	4
Solid state overload (1 NO–1 NC)	(#)

(#) Select code for solid state overload amp rating from ranges table below.

2-speed solid state overload ranges

Code	0 and 1		2		NEMA size 3 and 4	
	Hi amp	Lo amp	Hi amp	Lo amp	Hi amp	Lo amp
c	0.4–0.85	0.4–0.85	6.5–13.5	6.5–13.5	17–35	17–35
D	0.8–1.7	0.4–0.85	13–27	6.5–13.5	35–70	17–35
E	0.8–1.7	0.8–1.7	13–27	13–27	35–70	35–70
F	1.6–3.4	0.4–0.85	25–50	6.5–13.5	65–135	17–35
G	1.6–3.4	0.8–1.7	25–50	13–27	65–135	35–70
H	1.6–3.4	1.6–3.4	25–50	25–50	65–135	65–135
U	3.2–6.8	0.8–1.7	–	–	–	–
K	3.2–6.8	1.6–3.4	–	–	–	–
L	3.2–6.8	3.2–6.8	–	–	–	–
M	6.5–13.5	1.6–3.4	–	–	–	–
V	6.5–13.5	3.2–6.8	–	–	–	–
W	6.5–13.5	6.5–13.5	–	–	–	–
R	13–27	3.2–6.8	–	–	–	–
S	13–27	6.5–13.5	–	–	–	–
T	13–27	13–27	–	–	–	–

Step 5 (digit 13) select auxiliary contacts

Auxiliary contacts (per contactor)	Code
None	A
1 NO	B
1 NC	C
1 NO–1 NC	D ²
2 NO	E ²
2 NC	F ²

²Not available on 2 speed – 2 winding sizes 0-1.

Step 6 (digit 14) select monitoring options

Device	Code
None	A
Phase failure relay with undervoltage protection (panel mounted) — 190–480 V (PFR with UV)	C
Phase failure relay with undervoltage protection (panel mounted) — 575 V (PFR with UV)	D
Phase failure relay — 208 V (PFR)	E ³
Phase failure relay — 240 V (PFR)	F ³
Phase failure relay — 480 V (PFR)	G ³
Phase failure relay — 575 V (PFR)	H ³
Elapsed time meter (120 V/60 Hz) wired across coil (ETM)	L ⁴
ETM + PFR with UV (190–480 V)	L ⁴
ETM + PFR with UV (575 V)	N ⁴
ETM + PFR (208 V)	P ^{3,4}
ETM + PFR (240 V)	Q ^{3,4}
ETM + PFR (480 V)	R ^{3,4}
ETM + PFR (575 V)	S ^{3,4}

³Available for type 1 enclosure only.

⁴Requires 120 V control circuit voltage or CPT with 120 V secondary.

Enclosed combination magnetic starters

CR494 2-speed/2-winding, instantaneous trip circuit breaker

Ordering code configuration

Valid for NEMA sizes 0–4

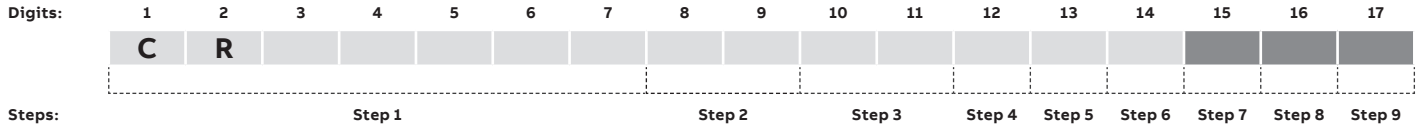

To configure the ordering code, use the tables below to fill in the digit boxes with the appropriate code.

Step 7 (digit 15) select pushbutton/selector switch

Pushbutton/selector switch — heavy duty	Code
None	A
Fast/slow/stop pushbutton	J
High/low/off pushbutton	K
High/low pushbutton and hand-off-auto (HOA) selector switch	L
Fast/slow pushbutton and hand-off-auto (HOA) selector switch	M
Hand-off-auto (HOA) and slow/fast selector switches	P
Hand-off-auto (HOA) and low/high selector switches	R
Slow-off-fast selector switch	T
Low-off-high selector switch	U
Fast-slow-off-auto selector switch	V
High-low-off-auto selector switch	W

Step 8 (digit 16) select pilot device

Pilot light (heavy duty CR104P style) type	Color — functionality	Code
None		A
LED lights	Red and amber across coils	2
	Red and green across coils	3
	Red and amber across coils and unwired green	5
Push-to-test lights	Red and amber across coils	S
	Red and green across coils	T
	Red and amber across coils and unwired green	Y

Step 9 (digit 17) select control options

Device	Code
None	A
1 relay, 2 NO-2 NC, 24/120 V coil — unwired	B ⁵
2 relays, 24/120 V coil — unwired	C ⁵
DIN rail — for customer use	D
12 point terminal strip — unwired (12 PT strip)	E
Space heater with NC contact	H ⁶
1 relay + 12 PT strip	J ⁵
2 relays + 12 PT strip	K ⁵
DIN rail + 12 PT strip + space heater	L ⁶
2 relays + 12 PT strip + space heater	M ^{5,6}
Time delay on relay, 24/120 V coil — unwired (TD)	N ⁵
Time delay off relay, 24/120 V coil — unwired (TD)	P ⁵
12 PT strip + TD ON	R ⁵
12 PT strip + TD OFF	S ⁵
12 PT strip + space heater + TD ON	T ^{5,6}
12 PT strip + space heater + TD OFF	U ^{5,6}

⁵Relay/timer coil voltage is equivalent to CPT secondary voltage. Requires minimum 100 extra VA CPT option.

⁶Maximum number of auxiliary contacts shall be reduced by 1.

General note:

If selecting factory installed and wired operator devices ((pushbuttons, selector switches and/or pilot lights), control circuit fusing, a control power transformer or 24 V/120 V separate sourced control is required, regardless of protective device rating.

Field-installed starter modification kits

Auxiliary contacts

NEMA sizes 0–6



CR305X100A

Auxiliary contacts can add to the versatility of magnetic starters by providing additional control circuits to do a variety of jobs without adding to the width of the starter.

Kits make it easy to add contacts to control accessory equipment such as indicating lights; to control sequencing of other motor starters; and in conjunction with a standard reversing starter and plugging switch, to plug-stop motors. Auxiliary contacts can be added to all across-the-line magnetic starters, combination magnetic starters, reversing and multi-speed starters.

Each auxiliary contact is rated 10 amperes AC, resistive load, NEMA “A600,” and is suitable for either right or left side mounting. An insulating shield is also provided between each auxiliary contact unit and the starter. Auxiliary contacts are furnished in the basic block design or as an adder block.

Each contact is marked NO or NC on the block and is not convertible.

Logic reed contacts suitable for low energy level circuits are also available. These are designed for applications on low-voltage control circuits (24 volts and below), such as inputs to computers and programmable starters.

Ordering code selection instructions

1. Order by quantity and complete ordering code.

Example: Three CR305X300A

Please reference the [NEMA full voltage power devices catalog](#) for additional technical data, selection and installation guides, and dimensional drawings.

Field-installed starter modification kits

Auxiliary contacts

For 300-line starters

Auxiliary contact kits — basic blocks

NEMA size	Contact configuration	Block design	Ordering code
0, 1	1 NO	Basic	CR305X100A
0, 1	1 NC	Basic	CR305X100B
0, 1	1 NO-1 NC	Basic	CR305X100C
2	1 NO	Basic	CR305X200A
2	1 NC	Basic	CR305X200B
2	1 NO-1 NC	Basic	CR305X200C
3, 4	1 NO	Basic	CR305X300A
3, 4	1 NC	Basic	CR305X300B
3, 4	1 NO-1 NC	Basic	CR305X300C
5, 6	1 NO	Basic	CR305X500A
5, 6	1 NC	Basic	CR305X500B
5, 6	1 NO-1 NC	Basic	CR305X500C

Auxiliary contact kits — adder blocks

NEMA size	Contact configuration	Block design	Ordering code
0-6	1 NO	Adder	CR305X100D ¹

Logic reed switch auxiliary contacts²

NEMA size	Contact configuration	Ordering code
00, 0, 1	1 NO-0 NC	CR305X100RA
00, 0, 1	0 NO-1 NC	CR305X100RB
00, 0, 1	1 NO-1 NC	CR305X100RC
2	1 NO-0 NC	CR305X200RA
2	0 NO-1 NC	CR305X200RB
2	1 NO-1 NC	CR305X200RC
3, 4	1 NO-0 NC	CR305X300RA
3, 4	0 NO-1 NC	CR305X300RB
3, 4	1 NO-1 NC	CR305X300RC
5, 6	1 NO-0 NC	CR305X500RA
5, 6	0 NO-1 NC	CR305X500RB
5, 6	1 NO-1 NC	CR305X500RC

Contact ratings — basic blocks

Standard block

AC volts	Continuous current amperes	Inrush current amperes
115	6.0	60
230	3.0	30
460	1.5	15
575	1.2	12

High fidelity contact basic block

120 V AC maximum 0.15 A maximum, 8 VA maximum resistive.

30 V DC maximum 0.15 A maximum, 4.5 VA maximum resistive.

Standard block

DC volts	Continuous current amperes	Inrush current amperes
125	1.1	-
250	0.5	-
-	-	-
-	-	-

¹First adder block must be mounted to a basic block. A second adder block can be added to the first adder block on size 2 through size 9 starters.

Four extra auxiliary contacts (not blocks) is the maximum that can be added to either a NEMA size 0 or 1 starter while five is the maximum extra auxiliary contacts that can be added to NEMA size 2 through 6 devices.

²CR305X logic reed switch auxiliary contacts may be ordered as a factory-installed modification. Order by description.

Please reference the [NEMA full voltage power devices catalog](#) for additional technical data, selection and installation guides, and dimensional drawings.

Field-installed starter modification kits

Surge suppression and control circuit fuses

NEMA sizes 00-6



CR305X146C

Surge suppression kit

NEMA size	Ordering code
0-6	CR305X146C

Control circuit fuse kits

NEMA size	No. of fuses	Fuse type	Ordering code
00-1	1	KTK	CR305X141A
00-1	2	KTK	CR305X141B
2	1	KTK	CR305X241A
2	2	KTK	CR305X241B
3, 4	1	KTK	CR305X341A
3, 4	2	KTK	CR305X341B
5, 6	1	KTK	CR305X541A
5, 6	2	KTK	CR305X541B
00-1	1	KTK-R	CR305X141C
00-1	2	KTK-R	CR305X141D
2	1	KTK-R	CR305X241C
2	2	KTK-R	CR305X241D
3, 4	1	KTK-R	CR305X341C
3, 4	2	KTK-R	CR305X341D
5, 6	1	KTK-R	CR305X541C
5, 6	2	KTK-R	CR305X541D

Please reference the [NEMA full voltage power devices catalog](#) for additional technical data, selection and installation guides, and dimensional drawings.

Field-installed starter modification kits

Combination starter transformers



CR305X146C

Standard capacity

VA capacity	NEMA size	Ordering code
50	0, 1	CR308XT1**A
100	2	CR308XT2**A
250	3	CR308XT3**A
250	4	CR308XT4**A
-	5	CR308XT5**A ¹

Extra capacity (100 watts)

VA capacity	NEMA size	Ordering code
150	0, 1	CR308XT1**B
150	2	CR308XT2**B
300	3	CR308XT3**B
300	4	CR308XT4**B
-	5	CR308XT5**B ²

**Voltage and frequency suffixes (60 Hz)

Suffix	
04	220–230–240/440–460–480-volt dual primary reconnectable, 110–115–120 volt secondary
05	550–575–600-volt primary, 110–115–120 volt secondary
23	200–208-volt primary, 115–120 volt secondary

¹Consists of a 50 VA transformer and a relay. Use primary voltage for starter/contactors coil.

²Consists of a 150 VA transformer and a relay. Use primary voltage for starter/contactors coil.

Contact nearest ABB Representative for additional information.

Please reference the [NEMA full voltage power devices catalog](#) for additional technical data, selection and installation guides, and dimensional drawings.

Field-installed starter modification kits

Control amplifier and space heater



CR305X702B

Control amplifier

Operation type	NEMA size	Ordering code
Non-reversing	00, 0, and 1	CR305X112A
Non-reversing	2	CR305X212A
Non-reversing	3 and 4	CR305X312A
Reversing	00, 0, 1, 2, 3 and 4	CR305X112P ¹

Space heater kits

NEMA size	Operating voltage	Ordering code
0-1	115	CR305X701D ²
0-1	230	CR305X701A
0-1	460	CR305X701B
0-1	600	CR305X701C
2, 3, 4	115	CR305X702D
2, 3, 4	230	CR305X702A
2, 3, 4	460	CR305X702B
2, 3, 4	600	CR305X702C
5, 6	115	CR305X705D ²
5, 6	230	CR305X705A
5, 6	460	CR305X705B
5, 6	600	CR305X705C

¹A quantity of two panel mount CR305X112P is required for use with reversing starters.

²If connected to control circuit transformer, 115-volt heater requires an extra-capacity transformer. Contact nearest ABB Representative for additional information.

Please reference the [NEMA full voltage power devices catalog](#) for additional technical data, selection and installation guides, and dimensional drawings.

Field-installed starter modification kits

Mechanical interlocks

Mechanical interlock kits

NEMA size	Mounting position	Baseplate	Ordering code
0-1	Horizontal	No	CR309X100B
2	Horizontal	No	CR309X200D
3-4	Horizontal	No	CR309X300B
5	Horizontal	Yes	CR309X501K
0-1	Vertical	Yes	CR309X102B
2	Vertical	Yes	CR309X202B
3-4	Vertical	Yes	CR309X302B

Please reference the [NEMA full voltage power devices catalog](#) for additional technical data, selection and installation guides, and dimensional drawings.

NEMA enclosed starters with IEC-style components

Table of contents

500-line starters	
Product overview	1-104
Enclosed non-combination starters	
CR505 contactor, single- and 3-phase	1-105
CR506 non-reversing, single- and 3-phase	1-105
CR509 reversing, single- and 3-phase	1-105
Accessories/kits	
Enclosure kits	1-112

500-line starters

Product overview

NEMA sizes 00–4
600 V maximum 50/60 Hz
100 hp maximum



CR506H1020259AAAP

ABB's latest technology of AF contactors with electronically controlled coils offers the benefits of a traditional IEC-style contactor while still having NEMA ratings for use in UL required markets. Especially suitable for handling the switching of resistance heating and capacitor circuit loads, their compact size also fits the needs of the panel building industry. In addition, they may be used for controlling AC motors where overload protection is provided separately.

Features

- The electronic system within the AF contactor continuously monitors the current and voltage apply to the coil. The contactor is safely operated in an always optimized condition and hum-free.
- AF coil and energy consumption is reduced up to 80%. This allows a reduction of the temperature rise, the size of control transformers and size of cabinets.
- With conventional contactor technology, use of an external surge suppressor is recommended. With AF technology, surges are handled by the contactor and never reach the control circuit.
- Attractive, modern, squared-off enclosure.
- Motor full-load current should not exceed continuous ampere rating of contactor.

Please reference the [NEMA full voltage power devices catalog](#) for additional technical data and dimensional drawings.

NEMA enclosed starters with IEC-style components

500-line

Ordering code configuration

Valid for NEMA sizes 0–4

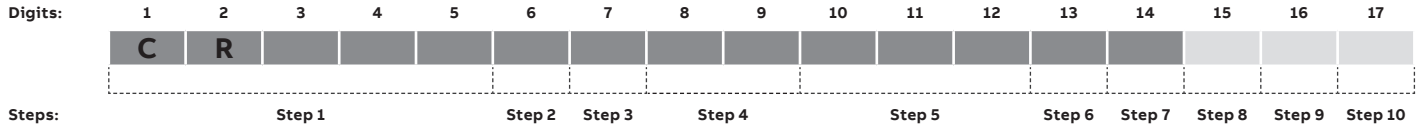

To configure the ordering code, use the tables below to fill in the digit boxes with the appropriate code.

Step 1 (digits 1–5) product line code

Product line	Code
Contactors, single and 3-phase	CR505
Non-reversing starter, single and 3-phase	CR506
Reversing starter, 3-phase	CR509

Step 2 (digit 6) input voltage

Input voltage	Phases	Code
120 V (max 7.5 hp)	Single-phase	J
240 V (max 15 hp)	Single-phase	M
208 V (max 40 hp)	Three-phase	C
240 V (max 50 hp)	Three-phase	E
480 V (max 100 hp)	Three-phase	H
600 V (max 100 hp)	Three-phase	N

Step 3 (digit 7) enclosure type

Enclosure type	Code
NEMA 1	1
NEMA 12	2
NEMA 4X	4
NEMA 3R	6

Step 4 (digits 8, 9) control voltage

Control circuit (coil) voltage and CPT	Phases	No CCF		CCF	
		No CPT	No CPT	No CPT	CPT
120 V	Three-phase	02	F2	-	-
208 V	Three-phase	08	F8	-	-
240 V	Three-phase	03	F3	-	-
480 V	Three-phase	04	F4	-	-
600 V	Three-phase	05 ¹	F5 ¹	-	-
24 V	Three-phase	09	F9	-	-
240 V/120 V with CPT	Three-phase	-	-	93	-
480 V/120 V with CPT	Three-phase	-	-	94	-
600 V/120 V with CPT	Three-phase	-	-	95	-
208 V/120 V with CPT	Three-phase	-	-	98	-
120 V	Single-phase	02	F2	-	-
240 V	Single-phase	03	F3	-	-
120 V/24 V with CPT	Single-phase	-	-	52	-
240 V/120 V with CPT	Single-phase	-	-	93	-
240 V/24 V with CPT	Single-phase	-	-	53	-

¹Coil with line voltage 575–600 V AC is not available

Step 5 (digits 10–12) horsepower rating

Horsepower rating	Phases	Code
¼	Single-phase	00A
½	Single-phase	00B
¾	Single-phase	00C
1	Single- and three-phase	001
1.5	Single- and three-phase	00D
2	Single- and three-phase	002
3	Single- and three-phase	003
5	Single- and three-phase	005
7.5	Single- and three-phase	007
10	Single- and three-phase	010
15	Single- and three-phase	015
20	Three-phase	020
25	Three-phase	025
30	Three-phase	030
40	Three-phase	040
50	Three-phase	050
60	Three-phase	060
75	Three-phase	075
100	Three-phase	100

Step 6 (digit 13) overload relay

Overload relay	Contacts	Code
Thermal overload, Class 10	Standard (1 NO + 1 NC)	9
Electronic overload ²	Standard (1 NO + 1 NC)	X
No overload ³		Z

²Not available with single phase

³Not available with non-reversing (CR506) or reversing starters (CR509)

Step 7 (digit 14) auxiliary contacts

Auxiliary contacts	Code
None	A
1 NO + 1 NC	D
2 NO + 2 NC ⁴	N

⁴Not available with reversing starters (CR509)

Please reference the [NEMA full voltage power devices catalog](#) for additional technical data and dimensional drawings.

NEMA enclosed starters with IEC-style components

500-line

Ordering code configuration

Valid for NEMA sizes 0–4

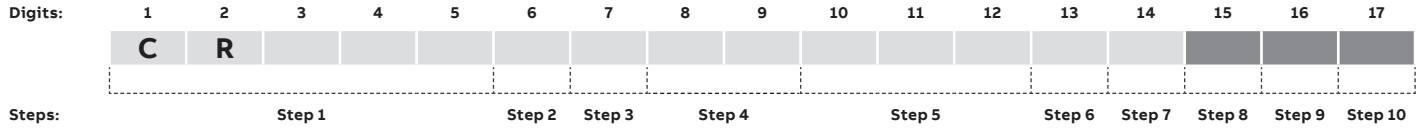

To configure the ordering code, use the tables below to fill in the digit boxes with the appropriate code.

Step 8 (digit 15) pushbutton/selector switch
Not valid for reversing starters; see following table

Pushbutton/selector switch	Code
None	A
Start (black) / Stop (red) pushbutton	J
Hand – off – auto (HOA) selector switch	L
Off – on selector switch	M

Step 8 (digit 15) pushbutton/selector switch
For reversing starters only

Pushbutton/selector switch	Code
None	A
FWD/REV/Stop pushbutton	J
HOA and FWD-REV selector switch	P
FWD-OFF-REV selector switch	T

Step 9 (digit 16) pilot lights (LED)
Not valid for reversing starters; see following table

Pilot light	Code
None	A
Red (across coil)	1
Red (across coil) and green (through NC auxiliary contact)	6

Step 9 (digit 16) pilot lights (LED)
For reversing starters only

Pilot light	Code
None	A
Red (across coil)	2

Step 10 (digit 17) overload range
Thermal overload
3-phase, 208 V

Horsepower rating	Overload range (A)	Code
½	1.7 to 2.3	A
½	2.3 to 3.1	B
¾	3.1 to 4.2	C
1	4.2 to 5.7	D
1.5		
2		
1.5	5.7 to 7.6	E
2		
3	7.6 to 10	F
3		
5	10 to 13	G
5		
5	13 to 16	H
5	16 to 20	J
7.5		
10		
7.5	20 to 24	K
10		
7.5	24 to 29	L
10		
10	29 to 35	M
10	35 to 38	N
15	30 to 40	P
15	36 to 47	Q
20		
15	44 to 53	R
20		
20	50 to 60	S
20	57 to 67	T
25	48 to 60	U
25	57 to 68	V
30		
25	65 to 78	W
30		
25	75 to 87	X
30		
30	84 to 96	Y
40	66 to 90	1
40	80 to 110	2
40	100 to 135	3
50	80 to 110	4
50	100 to 135	5
60		
50	110 to 150	6
60		
50	130 to 175	7
60		
60	150 to 200	8

NEMA enclosed starters with IEC-style components

500-line

Ordering code configuration

Valid for NEMA sizes 0–4



To configure the ordering code, use the tables below to fill in the digit boxes with the appropriate code.

Step 10 (digit 17) overload range (continued)

Thermal overload
3-phase, 240 V

Horsepower rating	Overload range (A)	Code
½	1.3 to 1.7	A
½	1.7 to 2.3	B
½	2.3 to 3.1	C
¾	3.1 to 4.2	D
1	4.2 to 5.7	E
1.5		
2	5.7 to 7.6	F
1.5		
2		
3	7.6 to 10	G
3	10 to 13	H
5		
5	13 to 16	J
5	16 to 20	K
7.5		
7.5	20 to 24	L
10		
7.5	24 to 29	M
10	29 to 35	N
15	30 to 40	P
15	36 to 47	Q
20		
15	44 to 53	R
20		
20	50 to 60	S
25		
20	57 to 67	T
25		
30	57 to 68	U
30	65 to 78	V
30	75 to 87	W
30	84 to 96	X
40	66 to 90	Y
40	80 to 110	1
50		
40	100 to 135	2
50		
50	110 to 142	3
60	110 to 150	4
60	130 to 175	5
60	150 to 200	6
75		

Step 10 (digit 17) overload range

Thermal overload
3-phase, 480 V

Horsepower rating	Overload range (A)	Code
½	0.74 to 1.0	A
½	1 to 1.3	B
¾		
¾	1.3 to 1.7	C
1		
¾	1.7 to 2.3	D
1		
1.5		
1.5	2.3 to 3.1	E
2		
1.5	3.1 to 4.2	F
2		
3		
3	4.2 to 5.7	G
5	5.7 to 7.6	H
5	7.6 to 10	J
7.5		
7.5	10 to 13	K
10		
10	13 to 16	L
15		
15	16 to 20	M
15	20 to 24	N
20		
20	24 to 29	P
25		
20	29 to 35	Q
25		
25	35 to 38	R
30	30 to 40	S
30	36 to 47	T
40		
40	44 to 53	U
50		
40	50 to 60	V
50		
50	57 to 67	W
60	57 to 68	X
60	65 to 78	Y
75		
60	75 to 87	1
75		
75	84 to 96	2
100	80 to 110	3
100	110 to 135	4
100	110 to 142	5
125	110 to 150	6
125	130 to 175	7
150		
150	150 to 200	8

NEMA enclosed starters with IEC-style components

500-line

Ordering code configuration

Valid for NEMA sizes 0–4

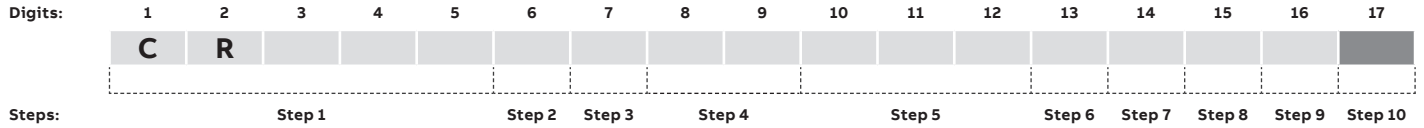

To configure the ordering code, use the tables below to fill in the digit boxes with the appropriate code.

Step 10 (digit 17) overload range (continued)

Thermal overload
3-phase, 600 V

Horsepower rating	Overload range (A)	Code
1/2	0.55 to 0.74	A
1/2	0.74 to 1.0	B
3/4		
1/2	1.0 to 1.3	C
3/4		
3/4	1.3 to 1.7	D
1		
1	1.7 to 2.3	E
1.5		
2		
1.5	2.3 to 3.1	F
2		
3		
3	3.1 to 4.2	G
3	4.2 to 5.7	H
5		
5	5.7 to 7.6	J
7.5		
7.5	7.6 to 10	K
10		
7.5	10 to 13	L
10		
15		
15	13 to 16	M
15	16 to 20	N
20		
20	20 to 24	P
25		
20	24 to 29	Q
25		
25	29 to 35	R
30		
30	35 to 38	S
40	30 to 40	T
40	36 to 47	U
50		
60		
40	44 to 53	V
50		
60		
50	50 to 60	W
60		
60	57 to 67	X
75	57 to 68	Y
75	65 to 78	1
75	75 to 87	2
75	84 to 96	3
100	66 to 90	4
100	80 to 110	5
125		
100	100 to 135	6
125		
125	110 to 142	7
150	100 to 135	8
150	110 to 150	9
150	130 to 175	0

Step 10 (digit 17) overload range

Thermal overload
Single-phase, 120 V

Horsepower rating	Overload range (A)	Code
1/4	4.2 to 5.7	A
1/3		
1/4	5.7 to 7.6	B
1/3		
1/2		
1/3	7.6 to 10	C
1/2		
1/2	10 to 13	D
3/4		
1	13 to 16	E
1		
1.5	16 to 20	F
1		
1.5		
2	20 to 24	G
1.5		
2	24 to 29	H
3	25 to 33	J
3	30 to 40	K
5	36 to 47	L
5	44 to 53	M
5	50 to 60	N
5	57 to 67	P
7.5		
7.5	75 to 87	Q
7.5	84 to 96	R

NEMA enclosed starters with IEC-style components

500-line

Ordering code configuration

Valid for NEMA sizes 0–4

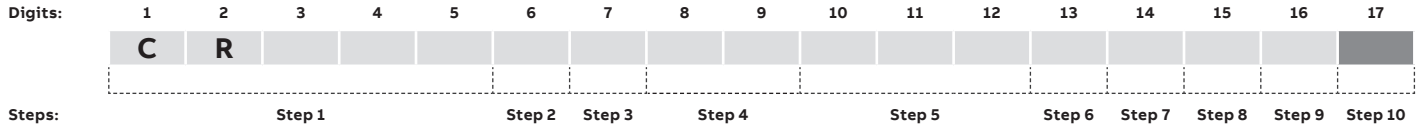

To configure the ordering code, use the tables below to fill in the digit boxes with the appropriate code.

Step 10 (digit 17) overload range (continued)

Thermal overload
Single-phase, 240 V

Horsepower rating	Overload range (A)	Code
¼	1.7 to 2.3	A
¼	2.3 to 3.1	B
½		
¼	3.1 to 4.2	C
½		
½		
½	4.2 to 5.7	D
¾		
¾	5.7 to 7.6	E
1		
1.5		
¾	7.6 to 10	F
1		
1.5		
2		
1	10 to 13	G
1.5		
2		
3		
2	13 to 16	H
3		
3	16 to 20	J
5	20 to 24	K
5	24 to 29	L
5	29 to 35	M
7.5	25 to 33	N
7.5	30 to 40	P
10		
7.5	36 to 47	Q
10		
10	44 to 53	R
15		
10	50 to 60	S
15		
15	57 to 67	T
20	65 to 78	U
20	75 to 87	V
20	84 to 96	W

Step 10 (digit 17) overload range

Electronic overload
3-phase, 208 V

Horsepower rating	Overload range (A)	Code
½	1.9 to 6.3	A
¾		
1		
1.5		
2		
3		
1.5	5.7 to 18.9	B
2		
3		
5		
7.5	9 to 30	C
10	15 to 45	D
15	20 to 56	E
20	25 to 70	F
25	36 to 100	G
30		
40	54 to 150	H
50	63 to 210	J
60		
75	115 to 380	K
100		
125		
150	150 to 500	L

Please reference the [NEMA full voltage power devices catalog](#) for additional technical data and dimensional drawings.

NEMA enclosed starters with IEC-style components

500-line

Ordering code configuration

Valid for NEMA sizes 0–4



To configure the ordering code, use the tables below to fill in the digit boxes with the appropriate code.

Step 10 (digit 17) overload range (continued)
 Electronic overload
 3-phase, 240 V

Horsepower rating	Overload range (A)	Code
½	0.8 to 2.7	A
¾		
1		
1.5		
¾	1.9 to 6.3	B
1		
1.5		
2		
2	5.7 to 18.9	C
3		
5		
7.5	9 to 30	D
10	15 to 45	E
15		
20	25 to 70	F
25		
30	36 to 100	G
40	54 to 150	H
50		
60	63 to 210	J
75		
100	115 to 380	K
125		
150		
200	150 to 500	L

Step 10 (digit 17) overload range
 Electronic overload
 3-phase, 480 V

Horsepower rating	Overload range (A)	Code
½	0.8 to 2.7	A
¾		
1		
1.5	1.9 to 6.3	B
2		
3		
5	5.7 to 18.9	C
7.5		
10		
15	9 to 30	D
20		
20	15 to 45	E
25		
30	20 to 56	F
40		
40	25 to 70	G
50		
60	36 to 100	H
75		
100	54 to 150	J
125	63 to 210	K
150		
200	115 to 380	L
250		
300		
350	150 to 500	M
400		

Please reference the [NEMA full voltage power devices catalog](#) for additional technical data and dimensional drawings.

NEMA enclosed starters with IEC-style components

500-line

Ordering code configuration

Valid for NEMA sizes 0–4



To configure the ordering code, use the tables below to fill in the digit boxes with the appropriate code.

Step 10 (digit 17) overload range (continued)

Electronic overload
3-phase, 600 V

Horsepower rating	Overload range (A)	Code
½	0.8 to 2.7	A
¾		
1		
1.5		
2		
2	1.9 to 6.3	B
3		
5		
7.5	5.7 to 18.9	C
10		
15		
20	9 to 30	D
25		
25	15 to 45	E
30		
40	20 to 56	F
50		
60	25 to 70	G
75	36 to 100	H
100	54 to 150	J
125		
150	63 to 210	K
200		

Step 10 (digit 17) overload range

Electronic overload
Single-phase, 240 V

Horsepower rating	Overload range (A)	Code
¾	1.9 to 6.3	A
½		
½		
¾	5.7 to 18.9	B
1		
1.5		
2		
3		
5	9 to 30	C
7.5	20 to 56	D
10		
15	25 to 70	E
20	36 to 100	F

Step 10 (digit 17) overload range

Electronic overload
Single-phase, 120 V

Horsepower rating	Overload range (A)	Code
¾	1.9 to 6.3	A
¾	5.7 to 18.9	B
½		
½		
¾		
1		
1.5		
2	9 to 30	C
3	20 to 56	D
5		
7.5	36 to 100	E

Please reference the [NEMA full voltage power devices catalog](#) for additional technical data and dimensional drawings.

NEMA enclosed starters with IEC-style components

Enclosure kits

Enclosure kits include: enclosure, ground wire, installation instructions for internal components and pre-drilled mounting holes. Internal components such as contactors, overloads and control power transformers must be purchased separately.

Enclosure kits

Type code	Ordering code	For use with	Space in enclosure for control power transformer	Pilot device knockout holes	NEMA type enclosure
ENCX1W113C5	1SQA012852R0001	AF09-38, AF..N00-1, DP20-60, CR360 30A contactors CR460 contactors	Yes No	Yes Yes	1
ENCX1W112C1	1SQA012844R0001	AF09-30, AFN00-1, DP60, CR360 30A contactors	No	No	1
ENCX1W115C4	1SQA012861R0001	AF40-65/AFN, DP75-90, CR360 60A, CR460 30A contactors	Yes	Yes	1
ENCX1W114C1	1SQA012854R0001	AF38-65, AF..N2, DP75-90, CR360 60A contactors	No	No	1
ENCX1W117C1	1SQA012868R0001	AF80-96, AF..N3 contactors, starters, reversers	Yes	Yes	1
ENCX1W117C2	1SQA012869R0001	AF80-96, AF..N3 contactors, starters, reversers	No	No	1
ENCX1W117C5	1SQA012872R0001	AF116-146, AF..N4 contactors, starters, reversers	Yes	Yes	1
ENCX1W117C6	1SQA012873R0001	AF116-146, AF..N4 contactors, starters, reversers	Yes	No	1
ENCX2W112C1	1SQA012769R0001	AF09-30, AF..N00-1, DP-60, CR360L 30A contactors	No	No	12/3R
ENCX2W112C2	1SQA012770R0001	AF09-30, AF..N00-1 starters	No	No	12/3R
ENCX2W112C3	1SQA012771R0001	AF09-30, AF..N00-1 Reversing starters + Electronic overload	No	No	12/3R
ENCX2W112C4	1SQA012772R0001	AF09-30, AF..N00-1 Reversing starters + Thermal overload	No	No	12/3R
ENCX2W113C4	1SQA012776R0001	AF09-38, AF..N00-1 starters and reversers	Yes	Yes	1
ENCX2W113C5	1SQA012777R0001	AF09-38, AF..N00-1, DP20-60, CR360L 30A contactors CR460 contactors	Yes No	Yes Yes	1
ENCX2W114C1	1SQA012779R0001	AF38-65, AF..N2, DP75-90, CR360L 60A starters	No	No	1
ENCX2W114C2	1SQA012780R0001	AF38-65, AF..N2 starters	No	No	1
ENCX4W105C5	1SQA012814R0001	AF09-38, AF..N00-1, DP20-60, CR360L 30A contactors CR460 contactors	Yes No	Yes Yes	4X
ENCX4W107C4	1SQA012823R0001	AF40-65/AF..N, DP75-90, CR360 60A, CR460 30 A contactors	Yes	Yes	4X
ENCX4W109C1	1SQA012831R0001	AF80-96, AF..N3 contactors, starters, reversers	Yes	Yes	4X
ENCX4W109C2	1SQA012832R0001	AF80-96, AF..N3 contactors, starters, reversers	No	No	4X
ENCX4W109C5	1SQA012835R0001	AF116-146, AF..N4 contactors, starters, reversers	Yes	Yes	4X
ENCX4W109C6	1SQA012836R0001	AF116-146, AF..N4 contactors, starters, reversers	Yes	No	4X
ENCX4W104C1	1SQA012806R0001	AF09-30, AF..N00-1, DP-60, CR360 30 A contactors	No	No	4X
ENCX4W106C1	1SQA012816R0001	AF38-65, AF..N2, DP75-90, CR360L 60A starters	No	No	4X
ENCX1W113C4	1SQA012851R0001	AF09-38, AF..N00-1 starters and reversers	Yes	Yes	12/3R
ENCX1W115C2	1SQA012859R0001	AF40-65, AF..N2 starters and reversers	Yes	Yes	12/3R
ENCX1W112C2	1SQA012845R0001	AF09-30, AF..N00-1 starters	No	No	12/3R
ENCX1W114C2	1SQA012855R0001	AF38-65, AF..N2 starters	No	No	12/3R
ENCX2W114C3	1SQA012781R0001	AF38-65, AF..N2 reversers with TF42, 65, EF45 overload	No	No	12/3R
ENCX2W114C4	1SQA012782R0001	AF38-65, AF..N2 Reverser with EF65 overload	No	No	12/3R
ENCX2W115C2	1SQA012784R0001	AF40-65, AF..N2 starters and reversers	Yes	Yes	12/3R
ENCX2W115C4	1SQA012786R0001	AF40-65/AF..N, DP75-90, CR360 60 A, CR460 30 Amps contactors	Yes	Yes	12/3R
ENCX4W105C4	1SQA012813R0001	AF09-38, AF..N00-1 starters and reversers	Yes	Yes	4X
ENCX4W107C2	1SQA012821R0001	AF40-65, AF..N2 starters and reversers	Yes	Yes	4X
ENCX4W104C3	1SQA012808R0001	AF09-30, AF..N00-1 starters	No	No	4X
ENCX4W106C2	1SQA012817R0001	AF38-65, AF..N2 starters	No	No	4X
ENCX1W112C4	1SQA012847R0001	AF09-30, AF..N00-1 reversers with Thermal overload	No	No	1
ENCX1W112C3	1SQA012846R0001	AF09-30, AF..N00-1 reversers with Electronic overloads	No	No	1
ENCX1W114C3	1SQA012856R0001	AF38-65, AF..N2 reversers with TF42, 65, EF45 overloads	No	No	1
ENCX1W114C4	1SQA012857R0001	AF38-65, AF..N2 reversers with EF65 overloads	No	No	1
ENCX2W117C1	1SQA012793R0001	AF80-96, AF..N3 contactors, starters, reversers	Yes	Yes	12/3R
ENCX2W117C2	1SQA012794R0001	AF80-96, AF..N3 contactors, starters, reversers	No	No	12/3R
ENCX2W117C5	1SQA012797R0001	AF116-146, AF..N4 contactors, starters, reversers	Yes	Yes	12/3R
ENCX2W117C6	1SQA012798R0001	AF116-146, AF..N4 contactors, starters, reversers	Yes	No	12/3R
ENCX4W104C4	1SQA012809R0001	AF09-30, AF..N00-1 reversers with Electronic/Thermal overload	No	No	4X
ENCX4W106C3	1SQA012818R0001	AF38-65, AF..N2 reversers with TF42, 65, EF45 overload	No	No	4X
ENCX4W106C4	1SQA012819R0001	AF38-65, AF..N2 reversers with EF65 overload	No	No	4X

Please reference the [NEMA full voltage power devices catalog](#) for additional technical data and dimensional drawings.

Overload relays

Table of contents

Thermal overload relays

CR324 product overview	1-114
CR324 thermal overload relays	1-115

Solid-state overload relays

CR324X product overview	1-116
CR324X solid-state overload relays	1-117

Heaters

CR123 product overview and selection	1-118
CR123 heaters NEMA size 00–2	1-119
CR123 heaters NEMA size 3–5	1-120
CR123 heaters for CR324 overload relays	1-121

Thermal overload relays

CR324 product overview

600 V AC/250 V DC, 3-pole
135 maximum amperes continuous

The panel-mount block overload relay provides overload protection for motors having full-load currents up to 135 amperes. The relays are furnished complete for use on control panels. When an overload condition occurs in any of the three legs in which heaters are inserted, it will cause the relay to trip, opening a normally closed contact, and, as an option, closing a normally open contact.

Standard and ambient compensated forms with various contact arrangements are available. A normally open circuit may be connected to a signal light, an alarm bell or input circuit of a programmable controller, e.g., to provide indication of an overload relay trip.

Features

- Flexibility of operation — trip rating can be easily changed by replacing the front-accessible heaters.
- Dual bimetal current monitoring — additional bimetal strip “anticipates” the rate of temperature rise in the motor winding, effectively reducing trip time in locked rotor conditions. It prevents dangerous temperature overshoot in the motor windings.

Ordering code selection instructions

1. Order required relay by complete ordering code as shown in table.

Example: An open block-type relay with one normally closed contact is to be mounted in a control panel. Three-leg overload protection is needed and the full-load current of the motor being controlled is 40.5 amperes. Order: CR324D310A and three CR123C400B heaters.

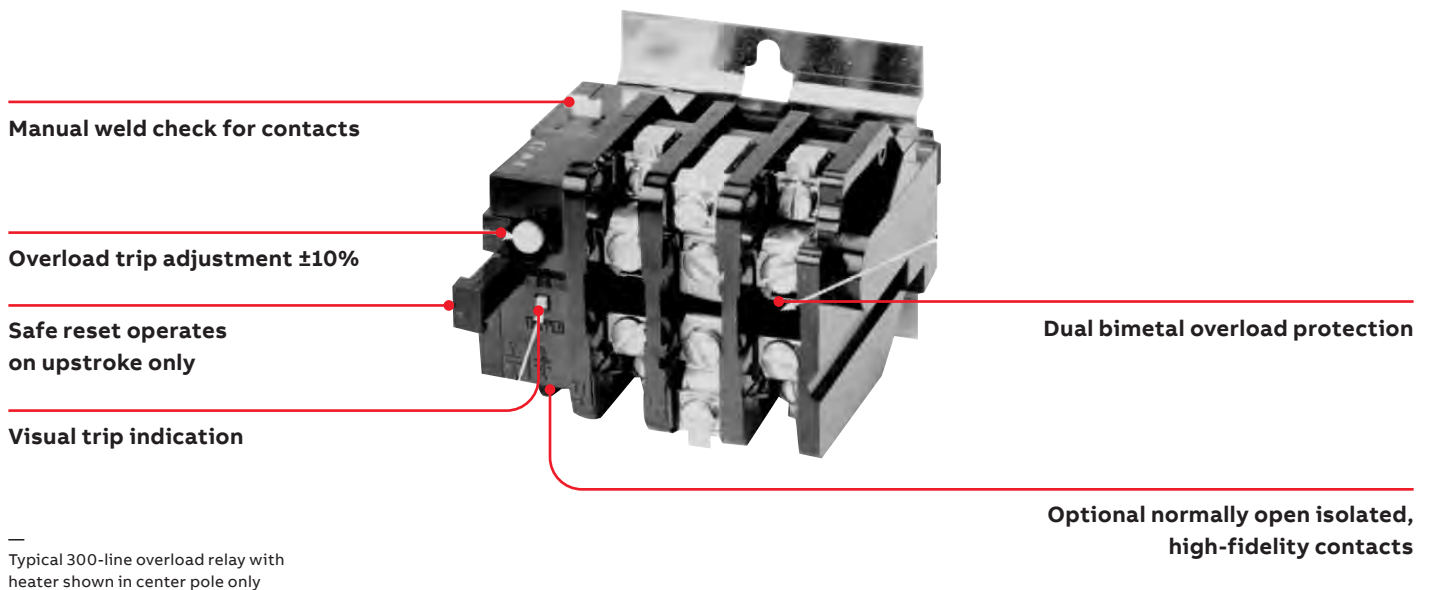

Please reference the [NEMA full voltage power devices catalog](#) for additional technical data and dimensional drawings.

Thermal overload relays

CR324 thermal overload relays

Block overload relays

Current rating (amps)	NEMA size	Contact configuration	Manual reset		Automatic reset	
			Standard panel-mount	Ambient-compensated panel-mount	Standard panel-mount	Ambient-compensated panel-mount
			Ordering code	Ordering code	Ordering code	Ordering code
27	1	1NC	CR324C310A	CR324C610A	CR324C310A1 ¹	CR324C610A1 ¹
27	1	1NO-1NC	CR324C360A	CR324C660A	-	-
45	2	1NC	CR324D310A	CR324D610A	CR324D310A1 ¹	CR324D610A1 ¹
45	2	1NO-1NC	CR324D360A	CR324D660A	-	-
90	3	1NC	CR324E310A	CR324E610A	CR324E310A1 ¹	CR324E610A1 ¹
90	3	1NO-1NC	CR324E360A	CR324E660A	-	-
135	4	1NC	CR324F310A	CR324F610A	CR324F310A1 ¹	CR324F610A1 ¹
135	4	1NO-1NC	CR324F360A	CR324F660A	-	-

¹For NO/NC (SPDT) contact forms, contact nearest ABB Representative.

Contact ratings

Continuous rating amperes	Make amperes	Recommended maximum interrupting capacity, amperes					
		DC circuits			AC circuits		
AC or DC		125 V	250 V	115 V	230 V	460 V	575 V
10	30	0.35	0.17	3	1.5	0.75	0.6

Accessories

External reset kit

Enclosure type	NEMA size	Reset distance (in.) behind panel	Ordering code
NEMA Type 1	00-5	1-6	CR124X100C
NEMA Type 12			
NEMA Type 4/4X	00-5	1-6	CR124X100D

For single or block overload relays and 200-, 300- and 400-line starters.

Please reference the [NEMA full voltage power devices catalog](#) for additional technical data and dimensional drawings.

Solid-state overload relays

CR324X product overview

3-pole, 600 V AC



CR324XCS

Features

- 2:1 Adjustable full load amps with tactile feedback dial
- Selectable 10/20/30 protection class
- Ambient insensitive within the stated operating temperature range of $-20\text{ }^{\circ}\text{C}$ to $+70\text{ }^{\circ}\text{C}$
- Built-in thermal memory to prevent hot motor restarts
- Protection against complete phase current loss
- Manual reset (standard) and remote reset (optional) 120 V AC
- Accuracy: $\pm 2\%$
- Repeatability: $\pm 2\%$
- Self-powered at 50% of minimum current range
- Size: 1–6 (0.40 A–540 A, 600 V, 50/60 Hz)
- Unbalance trip signal for PLC operation
- Manual trip
- Visual trip indication
- Standard isolated 1 NO and 1 NC auxiliary contact (A600, Q600)
- Built-in line/load straps
- Fits with existing 300-line starters
- Power factor correction terminals (sizes 1–4)
- DIN rail mountable sizes 1 and 2

Please reference the [NEMA full voltage power devices catalog](#) for additional technical data and dimensional drawings.

Solid-state overload relays

CR324X solid-state overload relays

Solid-state overload relays

Setting range amps	NEMA size	Fuse max. amps	Breaker max amps	Continuous amp rating	Panel mount		MRO and replacement	
					Ordering code	Ordering code		
0.4–0.85	00–1	3	15	27	CR324CXCP	CR324CXCS		
0.8–1.7	00–1	6	15	27	CR324CXDP	CR324CXDS		
1.6–3.4	00–1	12	15	27	CR324CXEP	CR324CXES		
3.2–6.8	00–1	25	25	27	CR324CXFP	CR324CXFS		
6.5–13.5	00–1	50	50	27	CR324CXGP	CR324CXGS		
13–27	00–1	100	100	27	CR324CXHP	CR324CXHS		
6.5–13.5	2	50	50	45	CR324DXGP	CR324DXGS		
13–27	2	100	100	45	CR324DXHP	CR324DXHS		
25–50	2	200	200	45	CR324DXJP	CR324DXJS		
17–35	3	125	125	90	CR324FXKP	CR324FXKS ¹		
35–70	3	250	250	90	CR324FXLP	CR324FXLS ¹		
65–135	3	500	400	90	CR324FXMP	CR324FXMS ¹		
17–35	4	125	125	135	CR324FXKP	CR324FXKS ¹		
35–70	4	250	250	135	CR324FXLP	CR324FXLS ¹		
65–135	4	500	400	135	CR324FXMP	CR324FXMS ¹		
35–70	5	–	–	–	–	CR324GXNS ²		
65–135	5	500	400	–	–	CR324GXPS ²		
130–270	5	600	800	–	–	CR324GXQS ²		
130–270	6	1200	800	–	–	CR324HXSK ³		
260–540	6	1200	800	–	–	CR324HXTK ³		
130–270	6	1200	800	–	–	CR324HXSS ⁴		
260–540	6	1200	800	–	–	CR324HXTS ⁴		

¹Reset is approximately 1" longer than on equivalent bimetal overloads. For ABB 300-line enclosures, perform the actions noted in the enclosure reset extension type table

²May be used as replacement for bimetal overload on size 5 starters. Use existing CTs.

³Must be used as solid-state replacement for bimetal overloads on size 6; since CT ratio changes, CTs are included.

⁴May be used as a replacement for existing solid-state overload on size 6. Use existing CTs.

Enclosure reset extension type	Adjustment required
Threaded rod (standard)	Cut threaded shaft 1" and adjust for 1/8" gap
"U" style, 2 1/8" long	Replace extension with ordering code 55-512811G005
"U" style, 1 1/2" long	Replace extension with ordering code 55-512811G002

Solid-state overload relay options

Item	NEMA size	Voltage	Ordering code
Remote reset	1–6	120 V AC	CR324XRRM02
Panel-mount adapter	1	–	CR324CXPMA
	2	–	CR324DXPMA

Please reference the [NEMA full voltage power devices catalog](#) for additional technical data and dimensional drawings.

Heaters

Product overview and selection

Magnetic starters — full voltage

Heater selection information

To prevent overloading the starter, do not select heater(s) for a motor of larger rating than the maximum given on the nameplate for the starter.

For continuous rated motors with a service factor of 1.15 to 1.25, select the heater with maximum motor amperes equal to or immediately greater than the motor full-load current (provides a maximum of 125% protection). For continuous rated motors with no service factor, multiply the full-load current of the motor by 0.90 and use this value to select the heater.

To protect the heater and starter during a short circuit, provide motor-branch-circuit protection in accordance with Table 430–152 in Article 430 of the National Electrical Code. In no case should the fuse rating exceed 4 times the motor full-load current for single-element fuses, or 2.25 times for dual-element fuses, or the fuse size listed in heater table under maximum fuse rating.

Caution: Overload relays, when furnished with automatic reset, should not be used with two-wire, maintained contact pilot devices such as pressure, float and limit switches, because inadvertent restarting of the motor can occur.

How to select heaters

The table below should be used to determine which column of motor full-load amperes applies for heater selection. Select in order, the basic device — including ordering code and description, the NEMA type of enclosure and the column to be used in the proper table by NEMA size.

If full-load amperes of the motor falls between two ratings, select heaters for the higher rating.

Ordering information

CR123F heaters being ordered for either customer's stock or any other purpose are to be specified in multiples of three (such as 3, 6, 9, 12, 15, etc.). Minimum order quantity is three.

Base ordering code starter/overload relay	Description	NEMA type enclosure	Quantity heaters required		Heater table column
CR306	Single-phase, 2-pole, size 00–2	Open	1		A
	Single-phase, 2-pole, size 00–2	1, 3R, 4/4X, 12	1		B
	Single-phase, 2-pole, size 3	Open	2		A
	Single-phase, 2-pole, size 6	1, 3R, 4/4X, 12	2		B
CR306	3-Phase, 3-pole, 3-leg protection	Open	3		C
	Standard, size 00–5				
	Ambient compensated, size 00, 0, 1, 2 and 5	Open	3		C
	Ambient compensated, size 3	Open	3		D
CR306, CR307, CR308, CR387, CR407, CR408, CR487	3-Phase, 3-pole, 3-leg protection	Open	3		E
	Standard, size 00–5	1, 3R, 4/4X, 12	3		D
	Ambient compensated, size 00, 0, 1, 2 and 5	1, 3R, 4/4X, 12	3		C
	Ambient compensated, size 3	1, 3R, 4/4X, 12	3		D
CR309	3-Phase, 3 3-pole, 3-leg protection				
	Standard, size 00–5	Open	3-Reverser	6-Two-speed	C
	Ambient compensated, size 00, 0, 1, 2 and 5	Open	3-Reverser	6-Two-speed	C
	Ambient compensated, size 3	Open	3-Reverser	6-Two-speed	D
CR309, CR410, CR411, CR490	3-Phase, 3 3-pole, 3-leg protection				
	Standard, size 00–5	1, 3R, 4/4X, 12	3-Reverser	6-Two-speed	D
	Ambient compensated, size 00, 0, 1, 2 and 5	1, 3R, 4/4X, 12	3-Reverser	6-Two-speed	C
	Ambient compensated, size 3	1, 3R, 4/4X, 12	3-Reverser	6-Two-speed	D
CR324	Ambient compensated, size 8	1, 3R, 4/4X, 12	3-Reverser	6-Two-speed	E
	Panel-mounted				See tables
All NEMA sizes 6–9	3-Phase, 3-leg protection, standard				See tables

Heaters

CR123 heaters NEMA size 00–2

All CR123C and CR123F heaters are packaged three to a carton. Items of these heaters, being ordered for either customer’s stock or any other purpose, are to be specified in multiples of three (such as 3, 6, 9, 12, 15, etc.). Minimum order quantity is three.

NEMA sizes 00, 0 and 1

Max. motor full-load amperes				
A	B	C	D	Heater ordering code
0.48	0.46	0.45	0.43	CR123C054A
0.55	0.50	0.49	0.48	CR123C060A
0.57	0.57	0.53	0.53	CR123C066A
0.65	0.62	0.59	0.58	CR123C071A
0.69	0.68	0.65	0.64	CR123C078A
0.83	0.80	0.76	0.74	CR123C087A
0.97	0.91	0.84	0.84	CR123C097A
1.03	0.99	0.93	0.92	CR123C109A
1.12	1.09	1.04	1.02	CR123C118A
1.26	1.22	1.15	1.10	CR123C131A
1.40	1.31	1.27	1.23	CR123C148A
1.46	1.46	1.39	1.38	CR123C163A
1.63	1.59	1.55	1.49	CR123C184A
1.79	1.74	1.73	1.67	CR123C196A
1.97	1.93	1.89	1.79	CR123C220A
2.25	2.13	2.05	1.98	CR123C239A
2.43	2.37	2.28	2.24	CR123C268A
2.60	2.52	2.47	2.43	CR123C301A
2.96	2.87	2.79	2.75	CR123C326A
3.57	3.39	3.31	3.25	CR123C356A
3.86	3.59	3.70	3.43	CR123C379A
4.43	4.31	4.06	4.03	CR123C419A
4.87	4.57	4.47	4.43	CR123C466A
5.37	5.31	4.95	4.94	CR123C526A
5.99	5.86	5.49	5.36	CR123C592A
6.39	6.19	5.91	5.77	CR123C630A
6.87	6.61	6.47	6.35	CR123C695A
7.71	7.61	7.20	6.92	CR123C778A
8.72	8.46	8.22	7.99	CR123C867A
9.50	9.35	8.72	8.47	CR123C955A
10.5	10.4	9.67	9.19	CR123C104B
11.7	11.3	10.4	10.0	CR123C113B
12.2	11.9	11.0	10.7	CR123C125B
13.5	13.0	12.4	12.0	CR123C137B
15.1	14.5	13.2	12.9	CR123C151B
17.5	17.4	15.4	15.1	CR123C163B
18.9	18.6	17.1	16.3	CR123C180B
20.8	20.5	18.1	17.9	CR123C198B
22.4	22.3	20.0	19.7	CR123C214B
25.5	24.7	21.5	21.2	CR123C228B
26.2	25.7	22.5	22.3	CR123C250B
27.0	27.0	23.9	23.5	CR123C273B
-	-	26.3	25.5	CR123C303B
-	-	27.0	27.0	CR123C330B

NEMA size 1P

Max. motor full-load amperes		
A	B	Heater ordering code
14.2	14.2	CR123C151B
17.3	17.3	CR123C163B
18.7	18.7	CR123C180B
20.6	20.6	CR123C198B
22.5	22.5	CR123C214B
24.7	24.7	CR123C228B
25.5	25.5	CR123C250B
26.7	26.7	CR123C273B
27.9	27.9	CR123C303B
32.1	32.1	CR123C330B
36.0	36.0	CR123C366B

NEMA size 2

Max. motor full-load amperes				
A	B	C	D	Heater ordering code
5.92	5.79	5.85	5.72	CR123C592A
6.23	6.12	6.47	6.30	CR123C630A
6.63	6.49	7.35	7.04	CR123C695A
7.72	7.59	8.06	7.91	CR123C778A
8.96	8.71	9.03	8.80	CR123C867A
9.92	9.19	9.61	9.27	CR123C955A
10.4	10.1	10.5	9.99	CR123C104B
11.7	11.2	11.6	11.1	CR123C113B
12.1	11.9	12.5	12.1	CR123C125B
13.5	12.6	13.6	13.1	CR123C137B
14.7	14.5	16.7	15.5	CR123C151B
18.3	17.7	17.9	16.8	CR123C163B
20.1	19.1	18.7	18.0	CR123C180B
22.3	21.4	20.4	19.7	CR123C198B
25.0	22.9	22.7	21.6	CR123C214B
27.7	24.7	24.7	23.9	CR123C228B
29.3	25.9	26.3	25.5	CR123C250B
30.7	27.1	29.5	28.2	CR123C273B
32.7	30.2	32.5	31.6	CR123C303B
35.6	34.8	36.7	34.7	CR123C330B
39.4	38.7	41.9	37.8	CR123C366B
45.0	45.0	43.2	40.6	CR123C400B
-	-	45.0	45.0	CR123C440B
-	-	-	-	CR123C460B

Please reference the [NEMA full voltage power devices catalog](#) for additional technical data and dimensional drawings.

Heaters

CR123 heaters NEMA size 3–5

All CR123C and CR123F heaters are packaged three to a carton. Items of these heaters, being ordered for either customer's stock or any other purpose, are to be specified in multiples of three (such as 3, 6, 9, 12, 15, etc.). Minimum order quantity is three.

NEMA size 3

Max. motor full-load amperes				
A	B	C	D	Heater ordering code
20.2	19.4	–	–	CR123F199B
21.0	20.1	–	–	CR123F218B
21.8	21.1	19.3	18.4	CR123F233B
24.5	24.6	22.1	21.1	CR123F243B
25.7	25.2	23.4	22.1	CR123F270B
29.2	29.2	27.0	26.1	CR123F300B
33.5	32.8	29.1	28.0	CR123F327B
37.0	35.1	31.8	31.3	CR123F357B
39.2	38.4	33.9	33.3	CR123F395B
42.7	40.4	37.6	34.3	CR123F430B
45.7	45.7	41.9	40.9	CR123F487B
48.4	48.9	47.7	44.7	CR123F567B
54.9	54.7	52.1	51.0	CR123F614B
62.7	58.6	55.8	52.0	CR123F658B
67.5	63.4	59.7	55.4	CR123F719B
77.1	72.3	68.1	63.3	CR123F772B
81.5	76.6	71.5	66.1	CR123F848B
86.3	83.8	78.2	73.5	CR123F914B
90.0	90.0	87.5	82.2	CR123F104C
–	–	90.0	90.0	CR123F114C

NEMA size 4

Max. motor full-load amperes			
C	D	E	Heater ordering code
32.2	32.0	32.0	CR123F357B
34.0	34.2	34.2	CR123F395B
36.8	36.7	36.7	CR123F430B
44.6	43.9	43.9	CR123F487B
48.4	46.6	46.6	CR123F567B
53.9	52.6	52.6	CR123F614B
57.4	55.6	55.6	CR123F658B
60.0	58.7	58.7	CR123F719B
69.5	67.1	67.1	CR123F772B
71.7	70.6	70.6	CR123F848B
79.9	76.3	76.3	CR123F914B
92.3	88.7	88.7	CR123F104C
97.0	93.4	93.4	CR123F114C
108.0	102.0	105.0	CR123F118C
118.0	110.0	114.0	CR123F133C
131.0	122.0	128.0	CR123F149C
135.0	131.0	131.0	CR123F161C
–	135.0	135.0	CR123F174C

NEMA size 5

Max. motor full-load amperes		
C	D	Heater ordering code
118	115	CR123C592A
128	125	CR123C630A
138	135	CR123C695A
155	151	CR123C778A
168	164	CR123C867A
184	179	CR123C955A
200	195	CR123C104B
221	215	CR123C113B
237	231	CR123C125B
262	255	CR123C137B
270	270	CR123C151B

Please reference the [NEMA full voltage power devices catalog](#) for additional technical data and dimensional drawings.

Heaters

CR123 heaters for CR324 overload relays

Overload relays

For CR324 standard and ambient compensated block overloads — panel-mounted.

All CR123C and 123F heaters are packaged three to a carton. Items of these heaters, being ordered for either customer's stock or any other purpose, are to be specified in multiples of three (such as 3, 6, 9, 12, 15, etc.). Minimum order quantity is three.

Three heaters

Max. motor full-load amperes	Heater ordering code	Max. fuse rating	Max. motor full-load amperes	Heater ordering code	Max. fuse rating
CR324C (Size 0, 1)					
0.39	CR123C054A	3	3.89	CR123C466A	15
0.42	CR123C060A	3	4.30	CR123C526A	15
0.45	CR123C066A	3	4.77	CR123C592A	15
0.51	CR123C071A	3	5.14	CR123C630A	20
0.56	CR123C078A	3	5.63	CR123C695A	20
0.65	CR123C087A	3	6.26	CR123C778A	25
0.73	CR123C097A	3	7.15	CR123C867A	25
0.81	CR123C109A	3	7.58	CR123C955A	30
0.90	CR123C118A	3	8.39	CR123C104B	30
1.00	CR123C131A	3	9.11	CR123C113B	35
1.10	CR123C148A	3	9.67	CR123C125B	35
1.21	CR123C163A	3	11.0	CR123C137B	40
1.35	CR123C184A	3	11.9	CR123C151B	45
1.50	CR123C196A	6	14.3	CR123C163B	50
1.64	CR123C220A	6	16.1	CR123C180B	60
1.78	CR123C239A	6	17.2	CR123C198B	60
1.98	CR123C268A	6	19.2	CR123C214B ¹	70
2.15	CR123C301A	6	20.6	CR123C228B ¹	80
2.42	CR123C326A	6	21.8	CR123C250B ¹	80
2.88	CR123C356A	10	23.4	CR123C273B ¹	80
3.22	CR123C379A	12	26.1	CR123C303B ¹	90
3.53	CR123C419A	12	27.0	CR123C330B ¹	90
CR324D (Size 2)					
5.14	CR123C630A	20	8.39	CR123C104B	30
5.63	CR123C695A	20	9.11	CR123C113B	35
6.26	CR123C778A	20	9.67	CR123C125B	35
7.15	CR123C867A	25	11.0	CR123C137B	40
7.58	CR123C955A	30	12.0	CR123C151B	45
14.4	CR123C163B	60	28.0	CR123C303B	100
16.3	CR123C180B	60	32.1	CR123C330B	110
17.3	CR123C198B	60	35.9	CR123C366B	125
19.3	CR123C214B	70	41.5	CR123C400B	150
20.9	CR123C228B	80	43.4	CR123C440B	150
22.9	CR123C250B	90	45.0	CR123C460B	150
24.7	CR123C273B	90	-	-	-

¹Size 1 only.

Three heaters

Max. motor full-load amperes	Heater ordering code	Max. fuse rating	Max. motor full-load amperes	Heater ordering code	Max. fuse rating
CR324E (Size 3)					
18.0	CR123F233B	70	44.4	CR123F567B	175
20.5	CR123F243B	80	48.4	CR123F614B	175
21.7	CR123F270B	80	52.4	CR123F658B	200
25.1	CR123F300B	90	57.0	CR123F719B	225
27.0	CR123F327B	100	64.5	CR123F772B	225
30.5	CR123F357B	110	68.8	CR123F848B	250
32.5	CR123F395B	125	75.7	CR123F914B	275
33.9	CR123F430B	125	86.2	CR123F104C	275
38.9	CR123F487B	150	90.0	CR123F114C	300
CR324F (Size 4)					
30.5	CR123F357B	100	68.6	CR123F848B	250
32.5	CR123F395B	125	75.7	CR123F914B	275
33.9	CR123F430B	125	86.2	CR123F104C	275
38.9	CR123F487B	150	93.0	CR123F114C	300
44.4	CR123F567B	175	109.0	CR123F118C	350
48.4	CR123F614B	175	123.0	CR123F133C	400
52.4	CR123F658B	200	131.0	CR123F149C	400
57.0	CR123F719B	225	135.0	CR123F161C	400
64.5	CR123F772B	225	-	-	-

Please reference the [NEMA full voltage power devices catalog](#) for additional technical data and dimensional drawings.

Manual motor starters

Table of contents

Manual motor starters	
CR101 product overview	1-123
CR101 single-phase manual motor starters	1-124
CR123 heaters for CR101 manual motor starters	1-127
CR101 enclosure components	1-128

Manual motor starters

CR101 product overview

**1 hp maximum at 115 V
or 230 V**
¾ hp maximum at 277 V
for 2-pole forms
25–60 Hz



CR101H



CR101H1



CR101H400H

The CR101 manual motor starters provide dependable overload protection for single-phase motors up to one horsepower (115 or 230 volts), and are an economical choice when undervoltage protection is not required.

Designed for starting and stopping single-phase motors up to 1 hp, these manual starters have provision for overload protection, and their low cost provides economical starter selection for applications where no undervoltage protection is required. This line of starters may be used on such equipment as grinders, conveyors, fans, mixers and blowers.

Features

- Terminal design — box terminals provide easy access for wiring.
- Molded plastic switch housing — protects starter mechanism.

Ordering code selection instructions

Order starter by complete ordering code and specify overload heater as a separate item by complete ordering code.

Examples:

1. A general-purpose enclosed starter for surface wall mounting is desired. The starter is to break both lines. Motor to be started with this device has a full-load current of 0.6 ampere.

Order:

(1) CR101H1 manual motor starter

(1) CR123H074A heater

2. The complete combination surface-mounted station, CR101H12, may also be ordered by components, e.g., order (1) CR101X10 flush plate; (1) CR101X14 box; and (1) CR101H manual starter. The other complete general-purpose manual starters may also be broken down in this manner.

Please reference the [NEMA full voltage power devices catalog](#) for additional technical data and dimensional drawings.

Manual motor starters

CR101 single-phase manual motor starters



CR101H

Open starters include an unmounted nameplate. Heaters can be selected from the table on the following pages and ordered as a separate item. One heater is required per starter (two for 2-speed forms and for combination starter CR101H13).

Toggle-operated non-reversing open

No. of poles	Ordering code
1	CR101Y ¹
2	CR101H ¹



CR101H1

Toggle-operated non-reversing enclosed NEMA type 1

No. of poles	Indicating light	Ordering code
1	No	CR101Y1 ¹
2	No	CR101H1 ¹
1	Yes	CR101Y11 ²
2	Yes	CR101H11 ²



CR101H400H

Lever-operated non-reversing enclosed NEMA type 3/4/12

No. of poles	Hubs	Ordering code
1	3/4-Inch hub on one end	CR101Y400H
2	3/4-Inch hub on one end	CR101H400H
1	3/4-Inch hub on both ends	CR101Y400J
2	3/4-Inch hub on both ends	CR101H400J

Multi-speed enclosed NEMA type 1 surface mount

No. of poles	Indicating light	Ordering code
1	None	CR101Y600B
1	Two	CR101Y610B ²
2	None	CR101H600B
2	Two	CR101H610B ²

Multi-speed enclosed NEMA type 1 gray flush-plate

No. of poles	Indicating light	Ordering code
1	None	CR101Y600A
1	Two	CR101Y610A ²
2	None	CR101H600A
2	Two	CR101H610A ²

¹Units are individually boxed and "poly-packed" 10 per carton as standard.

²Includes a 115/230-volt neon lamp(s). Not available at 277 volts.

Please reference the [NEMA full voltage power devices catalog](#) for additional technical data and dimensional drawings.

Manual motor starters

CR101 single-phase manual motor starters

Multi-speed enclosed NEMA type 1 stainless-steel flush-plate

No. of poles	Indicating light	Ordering code
1	None	CR101Y608A
1	Two	CR101Y618A ¹
2	None	CR101H608A
2	Two	CR101H618A ¹

¹Includes a 115/230-volt neon lamp(s). Not available at 277 volts.

Combination device enclosed NEMA type 1

No. of poles	Description	Ordering code
2	CR101H + base unit HOA	CR101H12
2	2 (CR101H)	CR101H13

Maximum horsepower ratings — AC or DC continuous carry — 16 amperes

Ordering code	No. of poles	Horsepower at 32 V AC	Horsepower at 115 V AC	Horsepower at 230 V AC	Horsepower at 277 V AC	Horsepower at 115 V DC	Horsepower at 230 V DC
CR101Y	1	¼	1	1	—	1	¼
CR101H	2	¼	1	1	¾	1	1

Please reference the [NEMA full voltage power devices catalog](#) for additional technical data and dimensional drawings.

Manual motor starters

CR101 single-phase manual motor starters



CR101JA1A



CR101BE1C

Pushbutton-operated non-reversing flush plate only

No. of poles	Pushbutton text	Ordering code
2	Start/Stop	CR101JA0A
2	On/Off	CR101JA0B
3	Start/Stop	CR101BA0A
3	On/Off	CR101BA0B

Pushbutton-operated non-reversing enclosed NEMA type 1

No. of poles	Pushbutton text	Ordering code
2	Start/Stop	CR101JA1A
2	On/Off	CR101JA1B
3	Start/Stop	CR101BA1A
3	On/Off	CR101BA1B

Pushbutton-operated multi-speed flush plate only

No. of poles	Pushbutton text	Ordering code
3	Fast/Stop/Slow	CR101BB0B

Pushbutton-operated multi-speed enclosed NEMA type 1

No. of poles	Pushbutton text	Ordering code
3	Fast/Stop/Slow	CR101BB1B

Pushbutton-operated reversing enclosed flush plate only

No. of poles	Pushbutton text	Ordering code
3	FWD/OFF/REV	CR101BE0A
3	FWD/STOP/REV	CR101BE0B
3	UP/STOP/DOWN	CR101BE0C

Pushbutton-operated reversing enclosed NEMA type 1

No. of poles	Pushbutton text	Ordering code
3	FWD/OFF/REV	CR101BE1A
3	FWD/STOP/REV	CR101BE1B
3	UP/STOP/DOWN	CR101BE1C

Please reference the [NEMA full voltage power devices catalog](#) for additional technical data and dimensional drawings.

Manual motor starters

CR123 heaters for CR101 manual motor starters

Overload heater units for CR101H, CR101Y

All CR123H heaters are packaged as single units.

The table below gives a proper size heater to trip the switch on approximately 125% motor current. Listed values are for motors with 1.15–1.25 service factor. For motors with 1.0 service factor continuously, multiply full-load current of motor by 0.9 and use this value to select heater. Contact nearest ABB Representative for recommendation on heaters to be used with definite-purpose motors. If motor full-load amperes falls between two ratings, select heater for the highest of those two. For 1.35 service factor motors, multiply full-load current of motor by 1.15 and use this value to select heater(s).

Maximum motor full-load amperes	Heater ordering code	Maximum motor full-load amperes	Heater ordering code	Maximum motor full-load amperes	Heater ordering code
.48	CR123H055A	1.78	CR123H205A	5.90	CR123H680A
.53	CR123H061A	1.95	CR123H224A	6.41	CR123H739A
.58	CR123H067A	2.13	CR123H245A	6.98	CR123H802A
.65	CR123H074A	2.32	CR123H267A	7.60	CR123H873A
.71	CR123H082A	2.53	CR123H291A	8.25	CR123H950A
.78	CR123H090A	2.76	CR123H317A	8.95	CR123H103B
.86	CR123H099A	3.01	CR123H346A	9.75	CR123H112B
.95	CR123H108A	3.27	CR123H377A	10.6	CR123H122B
1.04	CR123H120A	3.56	CR123H410A	11.4	CR123H132B
1.14	CR123H132A	3.88	CR123H446A	12.5	CR123H144B
1.25	CR123H144A	4.22	CR123H486A	13.6	CR123H157B
1.37	CR123H158A	4.60	CR123H529A	14.8	CR123H171B
1.49	CR123H172A	5.00	CR123H575A	16.0	CR123H186B
1.63	CR123H188A	5.43	CR123H625A		

Please reference the [NEMA full voltage power devices catalog](#) for additional technical data and dimensional drawings.

Manual motor starters

CR101 enclosure components



CR101X3



CR101X3



CR101X11



CR101X14

Enclosure components — single units

Description	Ordering code
Flush plate with 115/230-volt indicating light and screws	CR101X1
Standard flush plate with screws	CR101X2
Locking attachment (lock not included)	CR101X3
Cover (front with 115/230-volt neon indicating light and screws)	CR101X4
Standard cover (front with screws)	CR101X5
Enclosure back with screws (surface-mounting)	CR101X6
Stainless-steel flush plate with 115/230-volt indicating light and screws	CR101X7
Stainless-steel flush plate with screws	CR101X8

Combination plates and box

Description	Ordering code
Combination flush plate with hand-auto switch	CR101X10
Combination flush plate with hand-auto switch and 115/230-volt neon indicating light	CR101X11
Combination flush plate for (2) CR101 open starters	CR101X12
Combination flush plate for (2) CR101 open starters with (2) 115/230-volt neon indicating lights	CR101X13
Box (back) for combination forms	CR101X14

Please reference the [NEMA full voltage power devices catalog](#) for additional technical data and dimensional drawings.

Pumping panels

Table of contents

Pumping panels	
CR340, CR341 product overview	1-130
CR340 thermal magnetic breaker and instantaneous trip circuit breaker with thermal overload relay	1-131
CR340 instantaneous trip circuit breaker with solid-state electronic overload relay	1-132
CR341 fusible disconnect with thermal overload relay	1-133
CR341 fusible disconnect with solid-state electronic overload relay	1-134
CR340, CR341 pumping panels nomenclature	1-136
CR123 heaters for CR340/CR341 pumping panels	1-141

Pumping panels

CR340, CR341 product overview

**100 hp max. at 240 V,
600 hp max. at 600 V**



CR340 pump panel

Specifically designed for outdoor installation, these pumping panels provide full voltage control of squirrel-cage pump motors. They offer protection from motor burnouts due to overloading, protection against untimely restarts after power failure and protection of motor circuit against damage from short circuits. Enclosure provides additional space for customer to mount desired modifications and accessories. Custom panel designs available upon request. Contact nearest ABB representative or authorized distributor for additional information.

Ordering code selection instructions

1. ABB pumping panels are specifically designed for outdoor installation. They provide full-voltage control of squirrel-cage pump motors. Overload, undervoltage, and short-circuit protection are included as standard.

2. ABB pumping panels are available with traditional NEMA Class 20 bimetal thermal overloads, Class 10/20/30 selectable and adjustable electronic overloads with phase loss protection and Class 10 adjustable thermal overloads with differential protection.

3. In addition, pump panels can be provided with no overload relay, Class 10 overloads with fixed heaters, adjustable trip and differential trip, standard NEMA Class 20 overload relays or the Class 10/20/30 electronic overload relay.

4. Product notes

Fuse clips are sized for dual element time-delay fuses. Order heaters by complete ordering code.

Please reference the [NEMA full voltage power devices catalog](#) for additional technical data and dimensional drawings.

Pumping panels

CR340 thermal magnetic breaker and instantaneous trip circuit breaker with thermal overload relay

Thermal magnetic circuit breaker type

Coil voltage (60 Hz) ¹	NEMA size	Max. horsepower (3-phase)	CB rating (amps)	NEMA type 3R narrow		NEMA type 3R wide	
				Ordering code		Ordering code	
230-240	1	2	15	CR340K013AAA1AA		CR340C013AAA1AA	
230-240	1	3	20	CR340K013BAA1AA		CR340C013BAA1AA	
230-240	1	5	40	CR340K013FAA1AA		CR340C013FAA1AA	
230-240	1	7½	50	CR340K013HAA1AA		CR340C013HAA1AA	
230-240	2	10	50	CR340L013HAA1AA		CR340D013HAA1AA	
230-240	2	15	70	CR340L013KAA1AA		CR340D013KAA1AA	

¹50 Hz forms are available. Contact nearest ABB Representative for proper selection.

For pump panel without overload, change 8th digit in ordering code from "1" to "4."

Instantaneous trip circuit breaker type

Coil voltage (60 Hz) ¹	NEMA size	Max. horsepower (3-phase)	CB rating (amps)	NEMA type 3R narrow		NEMA type 3R wide	
				Ordering code		Ordering code	
230-240	1	3	15	CR340K213CAC1AA		CR340C213CAC1AA	
230-240	1	7½	30	CR340K213DAC1AA		CR340C213DAC1AA	
230-240	2	15	50	CR340L213EAC1AA		CR340D213EAC1AA	
230-240	3	30	100	-		CR340E213FAC1AA	
230-240	4	50	150	-		CR340F213GAC1AA	
230-240	5	100	400	-		CR340G213HAC1AA	
460-480	1	7½	15	CR340K214CAC1AA		CR340C214CAC1AA	
460-480	1	10	30	CR340K214DAC1AA		CR340C214DAC1AA ²	
460-480	2	25	50	CR340L214EAC1AA		CR340D214EAC1AA ²	
460-480	3	50	100	-		CR340E214FAC1AA ²	
460-480	4	100	150	-		CR340F214GAC1AA ²	
460-480	5	200	400	-		CR340G214HAC1AA	
460-480	6	400	600	-		CR340H214KAD1AA	

For pump panel without overload, change 8th digit in ordering code from "1" to "4."

Example: CR340K013AAA1AA becomes CR340K043AAA1AA.

¹50 Hz forms are available. Contact nearest ABB Representative for proper selection.

²Available with CL-type current limiter and UL listed 100 kA/C short-circuit rating; contact an ABB Representative for availability.

The 7th digit in the ordering code changes to "3."

General note:

Control circuit fusing included for instantaneous trip circuit breaker type.

Please reference the [NEMA full voltage power devices catalog](#) for additional technical data and dimensional drawings.

Pumping panels

CR340 instantaneous trip circuit breaker with solid-state electronic overload relay

Solid-state Class 10-20-30 electronic overload with adjustable setting

Instantaneous trip circuit breaker type solid-state Class 10-20-30 electronic overload

NEMA size	Max. horsepower (3-phase) at 230–240 V	Max. horsepower (3-phase) at 440–480 V	Max. CB rating (amps)	Overload range (amps)	NEMA type 3R narrow Ordering code	NEMA type 3R wide Ordering code
1	–	–	3	0.4–0.85	CR340K2X*CAC1AAC	CR340C2X*AAC1AAC
1	–	0.75	3	0.8–1.7	CR340K2X*CAC1AAD	CR340C2X*AAC1AAD
1	0.75	2	7	1.6–3.4	CR340K2X*CAC1AAE	CR340C2X*BAC1AAE
1	2	3	7	3.2–6.8	CR340K2X*CAC1AAF	CR340C2X*BAC1AAF
1	3	7.5	7	6.5–13.5	CR340K2X*CAC1AAG	CR340C2X*BAC1AAG
1	7.5	10	30	13–27	CR340K2X*DAC1AAH	CR340C2X*DAC1AAH
2	3	7.5	30	6.5–13.5	CR340L2X*DAC1AAG	CR340D2X*DAC1AAG
2	7.5	20	50	13–27	CR340L2X*EAC1AAH	CR340D2X*EAC1AAH
2	15	25	50	25–50	CR340L2X*EAC1AAJ	CR340D2X*EAC1AAJ
3	10	25	50	17–35	–	CR340E2X*EAC1AAK
3	25	50	100	35–70	–	CR340E2X*FAC1AAL
3	30	–	100	65–90	–	CR340E2X*FAC1AAM
4	10	25	100	17–35	–	CR340F2X*FAC1AAK
4	25	50	100	35–70	–	CR340F2X*FAC1AAL
4	50	100	150	65–135	–	CR340F2X*GAC1AAM
5	50	100	150	65–135	–	CR340G2X*GAC1AAP
5	100	200	400	130–270	–	CR340G2X*HAC1AAQ
6	100	200	400	130–270	–	CR340H2X*FAD1AAS
6	200	400	600	260–540	–	CR340H2X*GAD1AAT

*Insert number from coil table below in place of asterisk in ordering code for voltage/frequency desired.

*Coil table

(To complete ordering code)

Coil number	Voltage	Frequency
1	200–208 V	60 Hz
3	230–240 V	60 Hz
4	460–480 V	60 Hz
5	575–600 V	60 Hz
6	380–415 V	50 Hz

• NEMA sizes 1–3 rated 5,000 rms symmetrical amperes maximum.

• NEMA sizes 4 and 5 rated 10,000 rms symmetrical amperes maximum.

General note:

Control circuit fusing included for instantaneous trip circuit breaker type.

Please reference the [NEMA full voltage power devices catalog](#) for additional technical data and dimensional drawings.

Pumping panels

CR341 fusible disconnect with thermal overload relay

Thermal class 20 (fuses not included except where footnoted)

Class H fuse clips

Coil voltage (60 Hz)	NEMA size	Horsepower	Fuse clip rating (amps)	NEMA type 3R narrow	NEMA type 3R wide
				Ordering code	Ordering code
230-240	1	7½	30	CR341K013BAA1AA	CR341C013BAA1AA
230-240	2	15	60	CR341L013CAA1AA	CR341D013CAA1AA
230-240	3	20	60	-	CR341E013CAA1AA
230-240	3	30	100	-	CR341E013DAA1AA
230-240	4	50	200	-	CR341F013EAC1AA
230-240	5	60	200	-	CR341G013EAC1AA
230-240	5	100	400	-	CR341G013FAC1AA
460-480	2	10	30	CR341K014BAA1AA	CR341C014BAA1AA
460-480	2	15	30	CR341L014BAA1AA	CR341D014BAA1AA
460-480	2	25	60	CR341L014CAA1AA	CR341D014CAA1AA
460-480	3	30	60	-	CR341E014CAA1AA
460-480	3	50	100	-	CR341E014DAA1AA
460-480	4	60	100	-	CR341F014DAA1AA
460-480	4	100	200	-	CR341F014EAC1AA
460-480	5	125	200	-	CR341G014EAC1AA
460-480	5	200	400	-	CR341G014FAC1AA
460-480	6	400	600	-	CR341H014GAD1AA

For pump panel without overload, change 8th digit in ordering code from "1" to "4."

Class R fuse clips

Coil voltage (60 Hz)	NEMA size	Horsepower	Fuse clip rating (amps)	NEMA type 3R narrow	NEMA type 3R wide
				Ordering code	Ordering code
230-240	1	7½	30	CR341K113BAA1AA	CR341C113BAA1AA
230-240	2	15	60	CR341L113CAA1AA	CR341D113CAA1AA
230-240	3	20	60	-	CR341E113CAA1AA
230-240	3	30	100	-	CR341E113DAA1AA
230-240	4	50	200	-	CR341F113EAC1AA ¹
230-240	5	60	200	-	CR341G113EAC1AA ¹
230-240	5	100	400	-	CR341G113FAC1AA ¹
460-480	1	10	30	CR341K114BAA1AA	CR341C114BAA1AA
460-480	2	15	30	CR341L114BAA1AA	CR341D114BAA1AA
460-480	2	25	60	CR341L114CAA1AA	CR341D114CAA1AA
460-480	3	30	60	-	CR341E114CAA1AA
460-480	3	50	100	-	CR341E114DAA1AA
460-480	4	60	100	-	CR341F114DAA1AA
460-480	4	100	200	-	CR341F114EAC1AA ¹
460-480	5	125	200	-	CR341G114EAC1AA ¹
460-480	5	200	400	-	CR341G114FAC1AA ¹

For pump panel without overload, change 8th digit in ordering code from "1" to "4."

¹Control circuit fusing included.

Please reference the [NEMA full voltage power devices catalog](#) for additional technical data and dimensional drawings.

Pumping panels

CR341 fusible disconnect with solid-state electronic overload relay

Solid-state Class 10-20-30 electronic overload with adjustable setting

Class H fuse clips

NEMA size	Max. horsepower (3-phase) at 230–240 V	Max. horsepower (3-phase) at 440–480 V	Fuse clip rating (amps)	Max. fuse rating (amps)	Overload range (amps)	NEMA type 3R narrow Ordering code	NEMA type 3R wide Ordering code
1	–	–	30	3	0.4–0.85	CR341K0X*BAA1AAC	CR306341C0X*BAA1AAC
1	–	0.75	30	6	0.8–1.7	CR341K0X*BAA1AAD	CR306341C0X*BAA1AAD
1	0.75	2	30	10	1.6–3.4	CR341K0X*BAA1AAE	CR306341C0X*BAA1AAE
1	2	3	30	25	3.2–6.8	CR341K0X*BAA1AAF	CR306341C0X*BAA1AAF
1	3	7.5	30	30	6.5–13.5	CR341K0X*BAA1AAG	CR306341C0X*BAA1AAG
1	7.5	10	30	30	13–27	CR341K0X*BAA1AAH	CR306341C0X*BAA1AAH
2	3	7.5	30	30	6.5–13.5	CR341L0X*BAA1AAG	CR306341D0X*BAA1AAG
2	7.5	20	60	60	13–27	CR341L0X*CAA1AAH	CR306341D0X*CAA1AAH
2	15	25	60	60	25–50	CR341L0X*CAA1AAJ	CR306341D0X*CAA1AAJ
3	10	25	60	50	17–35	–	CR306341E0X*CAC1AAK ¹
3	25	50	60	60	35–70	–	CR306341E0X*CAC1AAL ¹
3	30	–	60	60	65–90	–	CR306341E0X*CAC1AAM ¹
4	10	25	200	200	17–35	–	CR306341F0X*EAC1AAK ¹
4	25	50	200	200	35–70	–	CR306341F0X*EAC1AAL ¹
4	50	100	200	200	65–135	–	CR306341F0X*EAC1AAM ¹
5	50	100	200	200	65–135	–	CR306341G0X*EAC1AAP ¹
5	100	200	400	400	130–270	–	CR306341G0X*FAC1AAQ ¹
6	100	200	600	600	130–270	–	CR306341H0X*GAD1AAS ¹
6	200	400	1200	1200	260–540	–	CR306341H0X*LAD1AAT ¹

* Insert number from coil table on next page in place of asterisk in ordering code for voltage/frequency desired.

¹ NEMA sizes 1–3 rated 5,000 rms symmetrical amperes maximum.

¹ NEMA sizes 4 and 5 rated 10,000 rms symmetrical amperes maximum.

¹ Control circuit fusing included.

Please reference the [NEMA full voltage power devices catalog](#) for additional technical data and dimensional drawings.

Pumping panels

CR341 fusible disconnect with solid-state electronic overload relay

Solid-state Class 10-20-30 electronic overload with adjustable setting

Class R fuse clips

NEMA size	Max. horsepower (3-phase) at 230-240 V	Max. horsepower (3-phase) at 440-480 V	Fuse clip rating (amps)	Max. fuse rating (amps)	Overload range (amps)	NEMA type 3R narrow Ordering code	NEMA type 3R wide Ordering code
1	-	-	30	3	0.4-0.85	CR341K1X*BAA1AAC	CR341C1X*BAA1AAC
1	-	0.75	30	6	0.8-1.7	CR341K1X*BAA1AAD	CR341C1X*BAA1AAD
1	0.75	2	30	10	1.6-3.4	CR341K1X*BAA1AAE	CR341C1X*BAA1AAE
1	2	3	30	25	3.2-6.8	CR341K1X*BAA1AAF	CR341C1X*BAA1AAF
1	3	7.5	30	30	6.5-13.5	CR341K1X*BAA1AAG	CR341C1X*BAA1AAG
1	7.5	10	30	30	13-27	CR341K1X*BAA1AAH	CR341C1X*BAA1AAH
2	3	7.5	30	30	6.5-13.5	CR341L1X*BAA1AAG	CR341D1X*BAA1AAG
2	7.5	20	60	60	13-27	CR341L1X*CAA1AAH	CR341D1X*CAA1AAH
2	15	25	60	60	25-50	CR341L1X*CAA1AAJ	CR341D1X*CAA1AAJ
3	10	25	60	50	17-35	-	CR341E1X*CAC1AAK
3	25	50	60	60	35-70	-	CR341E1X*CAC1AAL
3	30	-	60	60	65-90	-	CR341E1X*CAC1AAM
4	10	25	200	200	17-35	-	CR341F1X*EAC1AAK
4	25	50	200	200	35-70	-	CR341F1X*EAC1AAL
4	50	100	200	200	65-135	-	CR341F1X*EAC1AAM
5	50	100	200	200	65-135	-	CR341G1X*EAC1AAP
5	100	200	400	400	130-270	-	CR341G1X*FAC1AAQ

* Insert number from coil table below in place of asterisk in ordering code for voltage/frequency desired.

*Coil table

(To complete ordering code)

Coil number ¹	Voltage	Frequency
1	200-208 V	60 Hz
3	230-240 V	60 Hz
4	460-480 V	60 Hz
5	575-600 V	60 Hz
6	380-415 V	50 Hz

¹ NEMA sizes 1-3 rated 5,000 rms symmetrical amperes maximum.

² NEMA sizes 4 and 5 rated 10,000 rms symmetrical amperes maximum.

³ Horsepower ratings are based on standard NEC motor data and normal service conditions.

Please reference the [NEMA full voltage power devices catalog](#) for additional technical data and dimensional drawings.

Pumping panels

CR340, CR341 pump panel nomenclature

Ordering code configuration

Valid for NEMA sizes 1–5

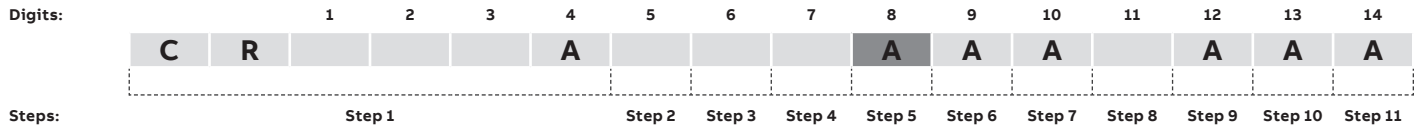

To configure the ordering code, use the tables below to fill in the digit boxes with the appropriate code.

Step 5 (digit 8) select disconnect (continued)

Table C: Fusible disconnect switch fuse clip sizes (CR341 only)

Code	1	2	3	4	5	Size
A ⁵	Disconnect switch less fuse clips					
B	30	30				
C	60	60	60			
D		100	100	100		
E				200	200	
F					400	
G						600
H						800
J						1000
L						1200
M						
N						

Table D: Class 10-20-30 electronic overload

Code	1	2	3	4	5	6	Size
C	0.4–0.85						Not available for NEMA size 7
D	0.8–1.7						
E	1.6–3.4						
F	3.2–6.8						
G	6.5–13.5	6.5–13.5					
H	13–27	13–27					
J		25–50					
K			17–35	17–35			
L			35–70	35–70			
M			65–90	65–135			
P					65–135		
Q					130–270	130–270	
T						260–540	

⁵NEMA Size 5 and 6 are labeled under UL 508A

Please reference the [NEMA full voltage power devices catalog](#) for additional technical data and dimensional drawings.

Pumping panels

CR340, CR341 pump panel nomenclature

Ordering code configuration

Valid for NEMA sizes 1–5

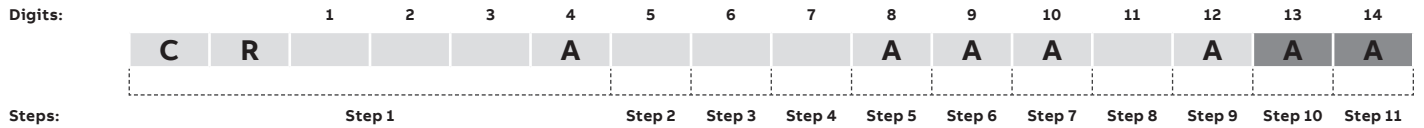

To configure the ordering code, use the tables below to fill in the digit boxes with the appropriate code.

Step 10 (digit 13) select relay type

Code	Option
A	None (standard)
B [§]	Under-voltage relay
C [§]	Under-voltage relay and phase failure relay
D [§]	Phase failure relay

Step 11 (digit 14) select overload range

Code	1	2	3	4	5	6	Size
C	0.4–0.85						Not available for NEMA size 7
D	0.8–1.7						
E	1.6–3.4						
F	3.2–6.8						
G	6.5–13.5	6.5–13.5					
H	13–27	13–27					
J		25–50					
K			17–35	17–35			
L			35–70	35–70			
M			65–90	65–135			
P					65–135		
Q					130–270	130–270	
T						260–540	

[§]Not available with NEMA size options K and L

Please reference the [NEMA full voltage power devices catalog](#) for additional technical data and dimensional drawings.

Pumping panels

CR123 heaters for CR340/CR341 pump panels

Class 20 overload heaters

For use with polyphase motors. For continuous rated motors with a service factor of 1.15 to 1.25, select heaters from the heater table for the motor full-load amperes. This provides a maximum of 125% protection. For continuous rated motors with 1.0 service factor, multiply the full-load amperes of the motor by 0.90 and use this value to select heaters.

Ordering information

All heaters listed are packaged in multiples of three. Items of these heaters should be ordered in quantities of three-unit multiples (such as 3, 6, 9, 12, etc.). The minimum order quantity is three.

Example: (For motors with FLA of 9.28)

Item 1: (2) CR341D013C for 2 motors.

Item 1A: (6) CR123C104B for starters.

Size 1 — Class 20 overload relay heaters

Motor full-load amps				
3-phase 3 heaters	Heater ordering code	Max. fuse rating (A)	Max. breaker rating (A)	TEC/TECL rating
0.41-0.45	CR123C054A	3	-	-
0.46-0.49	CR123C060A	3	15	-
0.50-0.53	CR123C066A	3	15	-
0.54-0.59	CR123C071A	3	15	-
0.60-0.65	CR123C078A	3	15	-
0.66-0.76	CR123C087A	3	15	3
0.77-0.84	CR123C097A	3	15	3
0.85-0.93	CR123C109A	3	15	3
0.94-1.04	CR123C118A	3	15	3
1.05-1.15	CR123C131A	3	15	3
1.16-1.27	CR123C148A	3	15	3
1.28-1.39	CR123C163A	3	15	3
1.40-1.55	CR123C184A	6	15	3
1.56-1.73	CR123C196A	6	15	3
1.74-1.89	CR123C220A	6	15	3
1.90-2.05	CR123C239A	6	15	3
2.06-2.28	CR123C268A	6	15	3
2.29-2.47	CR123C301A	6	15	3
2.48-2.79	CR123C326A	10	15	7
2.80-3.31	CR123C356A	10	15	7
3.32-3.70	CR123C379A	10	15	7
3.71-4.06	CR123C419A	15	15	7
4.07-4.47	CR123C466A	15	15	7
4.48-4.95	CR123C526A	15	15	7
4.96-5.49	CR123C592A	20	20	7
5.50-5.91	CR123C630A	20	20	7
5.92-6.47	CR123C695A	25	20	15
6.48-7.20	CR123C778A	25	20	15
7.21-8.22	CR123C867A	30	30	15
8.23-8.72	CR123C955A	30	30	15
8.73-9.67	CR123C104B	35	30	15
9.68-10.4	CR123C113B	35	30	15
10.5-11.0	CR123C125B	40	40	15
11.1-12.4	CR123C137B	45	40	15
12.5-13.2	CR123C151B	50	50	15, 30
13.3-15.4	CR123C163B	60	50	30
15.5-17.1	CR123C180B	60	50	30
17.2-18.1	CR123C198B	70	50	30
18.2-20.0	CR123C214B	70	50	30
20.1-21.5	CR123C228B	80	50	30
21.6-22.5	CR123C250B	80	70	30
22.6-23.9	CR123C273B	80	70	30
24.0-26.3	CR123C303B	90	70	30, 50
26.4-27.0	CR123C330B	90	70	50

Size 2 — Class 20 overload relay heaters

Motor full-load amps				
3-phase 3 heaters	Heater ordering code	Max. fuse rating (A)	Max. breaker rating (A)	TEC/TECL rating
5.48-5.85	CR123C630A	20	-	-
5.86-6.47	CR123C695A	20	-	-
6.48-7.35	CR123C778A	25	-	-
7.36-8.06	CR123C867A	30	-	-
8.07-9.03	CR123C955A	30	-	-
9.04-9.61	CR123C104B	35	30	15
9.62-10.5	CR123C113B	35	30	15
10.6-11.6	CR123C125B	40	40	15
11.7-12.5	CR123C137B	45	40	15
12.6-13.6	CR123C151B	50	50	15
13.7-16.7	CR123C163B	60	50	30
16.8-17.9	CR123C180B	60	50	30
18.0-18.7	CR123C198B	70	70	30
18.8-20.4	CR123C214B	80	70	30
20.5-22.7	CR123C228B	80	70	30
22.8-24.7	CR123C250B	90	70	30
24.8-26.3	CR123C273B	90	70	30
26.4-29.5	CR123C303B	100	100	30, 50
29.6-32.5	CR123C330B	100	100	50
32.6-36.7	CR123C366B	100	100	50
36.8-41.9	CR123C400B	100	100	50
42.0-43.2	CR123C440B	100	100	50
43.3-45.0	CR123C460B	100	100	-

Pumping panels

CR123 heaters for CR340/CR341 pump panels

Class 20 overload heaters (continued)

Size 3 — standard or ambient compensated Class 20 overload relay heaters

Motor full-load amps				
3-phase 3 heaters	Heater ordering code	Max. fuse rating (A)	Max. breaker rating (A)	TEC/TECL rating (A)
17.4–18.4	CR123F233B	70	70	30
18.5–21.1	CR123F243B	80	70	30
21.2–22.1	CR123F270B	80	70	30
22.2–26.1	CR123F300B	90	70	30
26.2–28.0	CR123F327B	100	100	50
28.1–31.3	CR123F357B	100	100	50
31.4–33.3	CR123F395B	100	100	50
33.4–34.3	CR123F430B	100	100	50
34.4–40.9	CR123F487B	100	100	50
41.0–44.7	CR123F567B	100	100	50, 100
44.8–51.0	CR123F614B	100	125	100
51.1–52.0	CR123F658B	100	125	100
52.1–55.4	CR123F719B	100	125	100
55.5–63.3	CR123F772B	100	150	100
63.4–66.1	CR123F848B	100	150	100
66.2–73.5	CR123F914B	100	150	100
73.6–82.2	CR123F104C	100	150	100
82.3–90.0	CR123F114C	100	150	100

Size 4 — Class 20 overload relay heaters

Motor full-load amps				
3-phase 3 heaters	Heater ordering code	Max. fuse rating (A)	Max. breaker rating (A)	TEC/TECL rating (A)
28.8–31.1	CR123F357B	110	100	50
31.2–33.3	CR123F395B	125	100	50
33.4–35.6	CR123F430B	125	100	50
35.7–42.6	CR123F487B	150	100	50, 100
42.7–45.2	CR123F567B	175	125	50, 100
45.3–51.1	CR123F614B	175	150	100
51.2–53.9	CR123F658B	200	150	100
54.0–56.9	CR123F719B	200	150	100
57.0–65.2	CR123F772B	200	175	100
65.3–68.6	CR123F848B	200	200	100
68.7–74.0	CR123F914B	200	200	100
74.1–86.0	CR123F104C	200	200	100, 150
86.1–90.7	CR123F114C	200	225	150
90.8–103	CR123F118C	200	225	150
104–109	CR123F133C	200	225	150
110–119	CR123F149C	200	225	150
120–131	CR123F161C	200	225	150
132–135	CR123F174C	200	225	150

Size 5 — Class 20 overload relay heaters

Motor full-load amps			
3-phase 3 heaters	Heater ordering code	Max. fuse rating (A)	Max. circuit rating (A)
109–118	CR123C592A	400	600
119–128	CR123C630A	400	600
129–138	CR123C695A	400	600
139–155	CR123C778A	400	600
156–168	CR123C867A	400	600
169–184	CR123C955A	400	600
185–200	CR123C104B	400	600
201–221	CR123C113B	400	600
222–237	CR123C125B	400	600
238–262	CR123C137B	400	600
263–270	CR123C151B	400	600

Size 6 — Class 20 overload relay heaters

Motor full-load amps		Heater ordering code
3-phase 3 heaters		
181–197		CR123C220A
198–214		CR123C239A
215–238		CR123C268A
239–258		CR123C301A
259–290		CR123C326A
291–346		CR123C356A
347–387		CR123C379A
388–424		CR123C419A
425–467		CR123C466A
468–516		CR123C526A
517–540		CR123C592A

Size 7 — Class 20 overload relay heaters

Motor full-load amps		Heater ordering code
3-phase 3 heaters		
346–387		CR123C326A
388–461		CR123C356A
462–515		CR123C379A
516–565		CR123C419A
566–622		CR123C466A
623–688		CR123C526A
689–763		CR123C592A
764–810		CR123C630A

Please reference the [NEMA full voltage power devices catalog](#) for additional technical data and dimensional drawings.