



CONTROL SECTION 3

Lighting contactors



Table of contents

Visit our lighting contactor information page at:
electrification.us.abb.com/products/contactors

Authorized ABB distributors: please refer to our new product configurators on empower.

3-4	Lighting contactors electrical features and benefits
3-5	Lighting contactors mechanical features and benefits
3-6	Lighting contactors CR460 series
3-6	Application information
3-7	The choice is yours: Three ways to order
3-8	Components
3-10	Enclosure accessories
3-12	Project submittal form
3-14	Lighting contactors CR463L
3-14	Standard assembled forms
3-16	Modified assembled forms - electrically held
3-18	Lighting contactors CR463M
3-18	Standard assembled forms
3-20	Modified assembled forms - mechanically held
3-22	Lighting contactors CR460, CR463
3-22	Technical data
3-23	Lighting contactors CR463L, CR463M
3-23	Wiring diagrams
3-24	Outlines and dimensions for estimating only
3-27	Lighting contactors CR360L
3-27	Application information
3-28	Selection
3-30	Technical data
3-31	Outlines and dimensions for estimating only
3-34	Lighting contactors CR160MC
3-34	Application information
3-35	Modified assembled forms - mechanically held
3-39	Technical data
3-40	Outlines and dimensions for estimating only

Electrical features and benefits

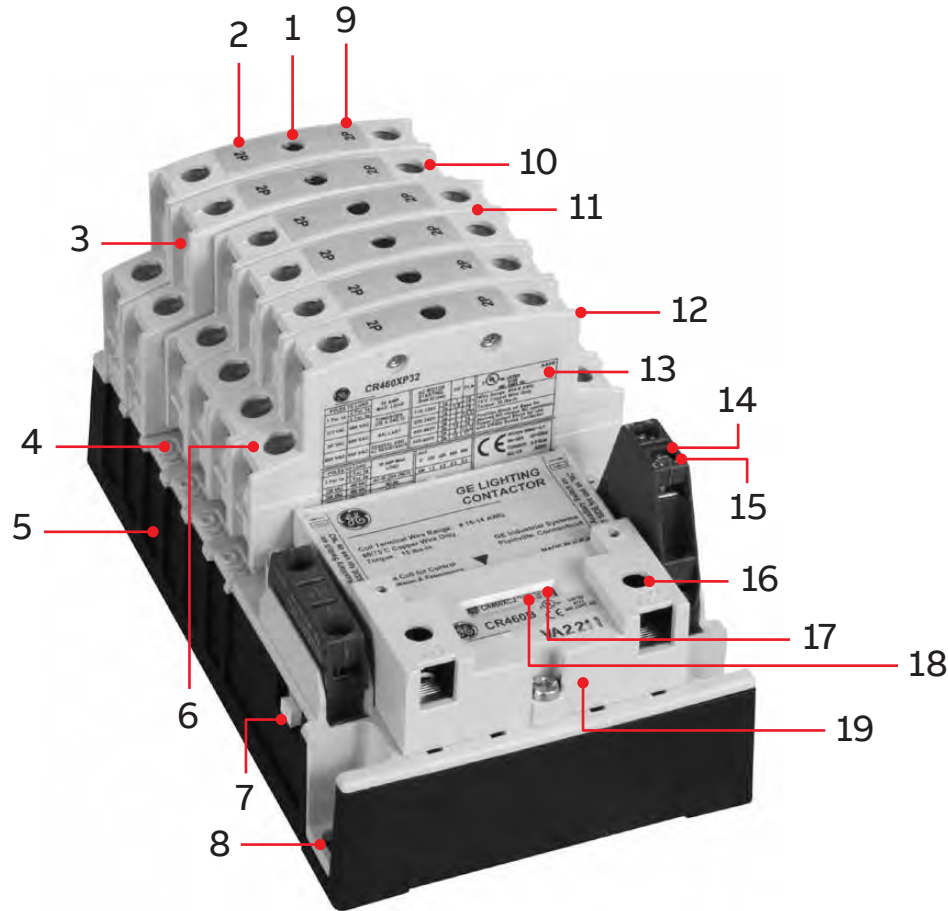

Electrically held contactor

CR460 Series lighting contactors deliver unprecedented versatility in application, simplicity in configuration and performance in operation. Ingenious design, rugged construction and a host of truly useful features make them uniquely appealing to all those who use them.

- | | |
|---|--|
| <ol style="list-style-type: none"> 1. Contact position indication - when button protrudes, contact is closed. 2. Power poles are available as single or double poles, creating 74 different circuit combinations. 3. Convenient side access field power wiring 4. Contact configuration indicator 5. Standard base for all pole configurations 6. Robust pole terminals accept up to two #8 AWG wires 7. Manual operator 8. Fast, sure three-point mounting 9. Enclosed contacts resist contaminants for greater reliability 10. Combination slotted/#2 Phillips screws 11. Common, easily installed power poles change from NO to NC (or vice versa) simply by unlatching and rotating 180° | <ol style="list-style-type: none"> 12. Power poles rated for the range of tasks: <ul style="list-style-type: none"> - 30A rated contacts - 15A motor rated - A600 Pilot duty rated - LED driver/electronic ballast rating: 3A/277V or 10A/120V 13. Easy-to-read rating label 14. Auxiliary contacts, rated A600, are suitable for use on low level circuits down to 12V, 5mA 15. Plug-in auxiliary contacts are NO when installed on the left side of the base, NC on the right 16. Finger and back-of-hand safe power terminals 17. Quick-view coil voltage 18. Easy-change coil 19. Low magnetic noise results in quiet operation |
|---|--|

Mechanical features and benefits

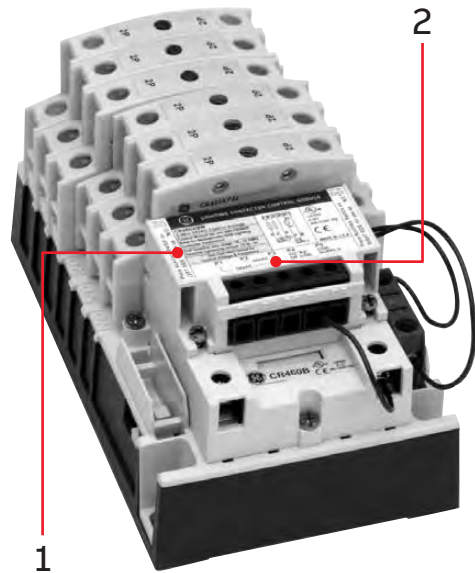

Mechanically held contactor

Mechanically held contactors also feature:

1. Two-or-three-wire control module:
 - low input VA permits long wire runs
 - verified contact status and has built-in delays that minimize excessively frequent signals from faulty controllers
 - come in a wide range of input voltages. Four modules cover input voltages from 24-277 VAC and 12-24 VDC. All modules may be used with coil voltage from 24 VAC-277 VAC.
2. Clear labeling shows control module rating, wire size and torque

Field configurable from standard electrically held contactor with simple, easy-to-install kits of control modules, latch mechanisms and auxiliary contacts.

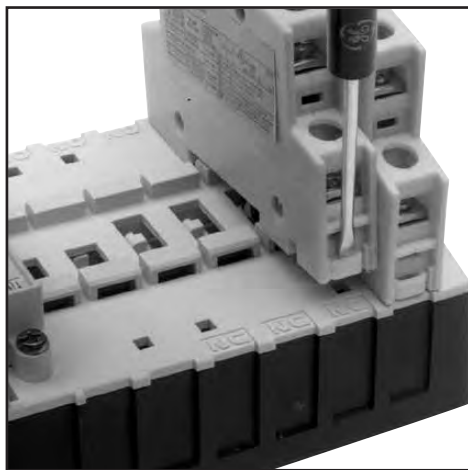

Power poles latch easily onto the base, and designating them as NO or NC is a simple matter of left or right positioning. Additional poles may be added at any time.

The ultimate in versatility, simplicity and performance

All CR460 series lighting contactors deliver unprecedented versatility in application, simplicity in configuration and performance in operation. Their revolutionary design and unique features meet most lighting control needs better than ever before.

- Modular design permits fast, on-site configuration
- 2-12 power poles
- 30 amp rating (LED driver/electronic ballast rating: 3A/277V or 10A/120V)
- Snap-in auxiliary contacts
- Common components for both electrically and mechanically held versions
- Continuously rated, interchangeable coils
- Finger-safe terminals

CR460 series



CR463L electrically held

Application information

CR460 lighting contactors switch ballast (fluorescent or HID), tungsten, LED driver/electronic ballast, and general-use loads and carry motor load, resistive and pilot duty ratings as well.

CR463L electrically held contactors

Operational mode

- 3-wire control is typically used when control is desired from multiple locations. The contactor is operated from a momentary pilot device and requires an auxiliary contact to be used as a holding interlock.
- 2-wire control is used for single location control with power continuously supplied to the coil for contactor operation.

CR463M mechanically held contactors

A mechanical latch with a 2- or 3-wire electronic control module delivers reliable performance and protection from such application abnormalities as line noise, leakage currents from controller outputs, or short repetitive commands burst from faulty controllers.

Mechanical operation

- Latches after contactor command and removes coil from circuit for noise-free operation
- Eliminates all coil losses after contactor is latched

Control module

- Coil operation and control circuit at same or different voltages
- Allows longer control wiring runs
- Microprocessor validates control signal before operation
 - will not respond to momentary voltage spikes or noise
 - operation command has built in delay (0.4 sec) to avoid multiple short-term commands that can cause contact fatigue or failure
 - feedback loop prevents contactor from getting out of sequence with switches, even after power failures

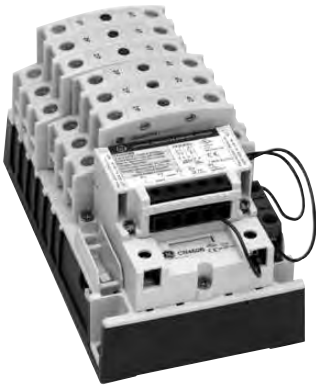

CR463M mechanically held

Operational modes

- 3 wire control is the choice for use with momentary devices allowing operation from multiple locations
 - a momentary pulse of energy operates contactor; a second pulse on alternate leg returns contactor to original state
- 2-wire control is the choice for single-output automatic operation or for operation from single-pole devices
 - latches contactor into position when voltage is applied to input terminals (coil is removed from circuit while control voltage is continuously supplied); disengages latch and returns contactor to original state when control voltage is removed.

CR460 series

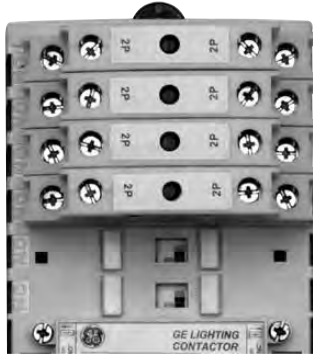

CR463L80AJA (8NO)

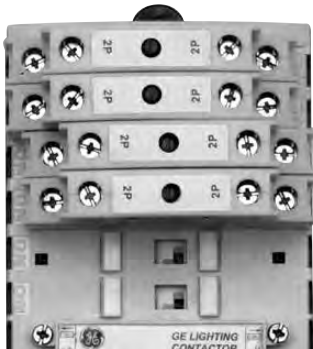

Contactors reconfigured as 4NO-4NC

3 ways to order CR460 series lighting contactors

Ordering the correct contactor for your application may be accomplished in any of three ways. Choose the one that's right for you.

1. Order components and assemble in minutes (see pages 3-8 and 3-9).

- Cost-effective
- Allows late-point configuration
- Greatest flexibility
- Parts in stock for immediate delivery

2. Order standard assembled contactor and rotate poles to meet pole requirements (see pages 3-14, 3-15, 3-18 and 3-19).

- Available from stock or short cycle for timely delivery
- Single product number to order
- Allows local stocking of most common assembled forms via pole reconfiguration

When you receive the contactor, simply reconfigure it to the NO-NC arrangement you require by rotating the appropriate power plate. It just takes a minute.

Example: 4NO-4NC required. Order CR463L80AJA.

3. Order assembled contactor configured to the exact application need (see pages 3-16, 3-17, 3-20 and 3-21).

- Order contactor as required by application
- Arrives fully assembled, ready to install

CR460 components



CR463L - basic contactor

Basic contactor

Combined with other appropriate components, basic contactors allow configuration into any available electrically or mechanically held model. Includes two power poles.

Contact configuration	Product number
1NO-1NC	CR463L11A*A
2NO	CR463L20A*A

Replace * in the product number with the appropriate digits from the Coil Voltage table. The resulting product number will be for an assembled contactor with no additional auxiliary contacts, pilot devices, pilot lights, control circuit fuses or CPTs.

Coil voltage

AC, 60Hz	AC, 50Hz	Electrically held	Mechanically held	Coil digit
24V	20V	•	•	C
28V	24V	•	•	D
115-120V	110V	•	•	J
200-208V	-	•	•	L
230-240V	220V	•	•	S
277V	240V	•	•	N
347V	-	•	¹	T
460-480V	440V	•	¹	U
575-600V	550V	•	¹	Y

¹Control module switching device rated 277V max; use CPT for higher voltage



CR460XP - power poles

Power poles

CR460 series basic contactors accept up to 6 single- or double-pole power poles. These can be used to form up to:

- 12 NO poles when 6 double-poles are used in the NO positions (1-6) or
- 8 NC poles with 4 double-poles in the NC positions (1-4) + NO poles with 2 double-poles in the 2 NO positions (5-6)

Type	Product number
Single pole	CR460XP31
Double pole	CR460XP32

Packaged individually and overpacked in multiple of 5.



CR460XM - conversion kits

Conversion kits for mechanically held contactors

Kits for converting electrically held contactors to a mechanically held version. Kits include control module, latch, latch cover and auxiliary contact(s) plus installation instructions. Conversion kits are suitable for coil voltages 277V and below. Use CPT to reduce coil voltage if line voltage is higher than 277V.

Coil voltage range	Control circuit wiring	Auxiliary contacts ¹	Control circuit voltage	Product number
24-277 Vac	2-wire	(1) 1 pole	24 Vac	CR460XMB
24-277 Vac	2-wire	(1) 1 pole	110-120 Vac	CR460XMC
24-277 Vac	2-wire	(1) 1 pole	200-277 Vac	CR460XMD
24-277 Vac	2-wire	(1) 1 pole	12-28 Vdc	CR460XME
24-277 Vac	3-wire	(2) 1 pole	24 Vac	CR460XMM
24-277 Vac	3-wire	(2) 1 pole	110-120 Vac	CR460XMN
24-277 Vac	3-wire	(2) 1 pole	200-277 Vac	CR460XMP
24-277 Vac	3-wire	(2) 1 pole	12-28 Vdc	CR460XMR

¹Auxiliary contact block required for feedback loop, alternate 2 pole blocks may be required for status feedback and/or pilot lights. See fuse and transformer kits table on page 3-11 for CPT selection. See wiring diagrams on page 3-23.

CR460 components



CR460XB - auxiliary contacts

Auxiliary contacts

Each contactor may use one single or one double auxiliary contact block on each side of the base. When installed on the left side the contacts are NO, when installed on the right side the contacts are NC. This allows a total of 2NO +2NC contacts maximum.

Type	Product number
Single pole	CR460XB1
Double pole	CR460XB2

See additional auxiliary contacts tables on pages 3-15 and 3-19 for contact selection data.

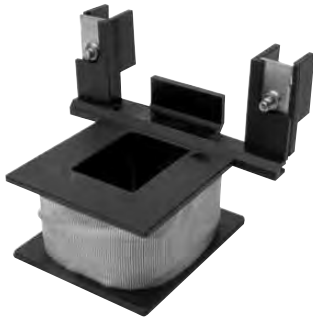

CR460XC - spare coils

Spare coils

Coil voltage @ 60Hz	Coil voltage @ 50Hz	Product number
24	20	CR460XCC
28	24	CR460XCD
115-120	110	CR460XCJ
200-208	-	CR460XCL
230-240	220	CR460XCS
277	240	CR460XCN
347	-	CR460XCT
460-480	440	CR460XCU
575-600	550	CR460XCY

CR460 enclosure accessories



Extended button

Enclosure kits (with no CPT or pilot light devices, lights)

Description	Enclosure type	Product number
Standard		
With no CPT or pilot device	NEMA Type 1	CR460XE1B
With no CPT or pilot device	NEMA Type 1 flush mount	CR460XE8B
With no CPT or pilot device	NEMA Type 12/3R	CR460XE2B
Oversized		
With provision for CPT and/or pilot devices, lights	NEMA Type 1	CR460XE1D
With provision for CPT and/or pilot devices, lights	NEMA Type 12/3R	CR460XE2D
With provision for CPT and/or pilot devices, lights	NEMA Type 4	CR460XE4D

See pages 3-25 to 3-26 for enclosure dimensions.

Pilot devices (requires oversize enclosure)

Pilot device type	For use with	Product number
Momentary ON/OFF push button	Electrically held with interlock aux. Mechanically held 3-wire control module	CR460XP1
Maintained ON/OFF or OFF/AUTO selector switch	Electrically held w/o interlock aux. Mechanically held 2-wire control module Mechanically held 3-wire control module	CR460XP2
Momentary ON/OFF selector switch, spring return to center	Electrically held with interlock aux. Mechanically held 3-wire control module	CR460XP3
Maintained H-O-A or ON/OFF/AUTO keyed selector switch	Electrically held w/o interlock aux. Mechanically held 3-wire control module	CR460XP4
Maintained H-O-A or ON/OFF/AUTO keyed selector switch (key removal all positions)	Electrically held w/o interlock aux. Mechanically held 3-wire control module	CR460XP5

Enclosure accessory kits contain accessory and complete installation wiring and hardware. Some kits contain multiple nameplates for alternate markings.



Standard

Pilot lights (requires oversize enclosure)

Pilot light type	Nameplate	Product number
Standard	ON or OFF	CR460XLB*
Push-to-test	ON or OFF	CR460XLD*

Pilot light kits come with interchangeable red and green lenses. Pilot lights may require auxiliary contacts. Replace * in pilot light product number with appropriate voltage digit from the table below. See extra contact limitations in the additional auxiliary contacts tables on pages 3-17 and 3-21.

Pilot light voltage

Voltage	Digit
24 Vac/dc	C
120 Vac	J
208 Vac	L
240 Vac	S
277 Vac	N
347 Vac	T
480 Vac	U
600 Vac	Y



Push-to-test

CR460 enclosure accessories



Control power transformer

Transformer kits - includes 2 primary and 2 secondary fuses. (Requires oversize enclosure)

	CPT primary volts	CPT secondary volts	Product number
100VA CPT kit ¹	208V	120V	CR460XTB
100VA CPT kit ¹	220-240V	120V	CR460XTC
100VA CPT kit ¹	277V	120V	CR460XTD
100VA CPT kit ¹	440-480V ¹	120V	CR460XTE
100VA CPT kit ¹	600V	120V	CR460XTF
100VA CPT kit ¹	120V	24V	CR460XTL
100VA CPT kit ¹	208V	24V	CR460XTM
100VA CPT kit ¹	220-240V ¹	24V	CR460XTN
100VA CPT kit ¹	277V	24V	CR460XTP
100VA CPT kit ¹	440-480V	24V	CR460XTR
100VA CPT kit ¹	600V	24V	CR460XTS

¹May be reconnected in field for 440-480 volts; requires substitution of two 0.5 amp primary fuses.

Control circuit fuse kit

For use with	Product number
Contactors without CPT	CR460XF

CR460 series lighting contactors - project submittal form

Item No. _____

Proposition No. _____

CR460 series lighting contactors feature:

- A modular design that permits fast, on-site configuration
- 2-12 power poles that latch easily onto the base as either NO or NC and that can be added at any time
- 30 amp rating (LED driver/electronic ballast rating: 3A/277V or 10A/120V)
- Snap-in auxiliary contacts
- Common components for both electrically and mechanically held versions
- Continuously rated, interchangeable coils
- Finger-safe terminals

Main power pole ratings

Maximum AC voltage and amp ratings			
Load type	Amps continuous	1 phase	3 phase
Ballast	30	347 Vac	600 Vac
General use	30	600 Vac	600 Vac
Tungsten	20	277 Vac	480 Vac
AC Resistive	30	600 Vac	600 Vac
LED Driver/ Electronic Ballast	10	120 Vac	-
	3	277 Vac	-

Maximum horsepower rating (normal starting duty)

	1 pole, single phase			3 poles, three phase		
	Volts	110-120V	220-240V	200-208V	220-240V	440-480V
HP	1	2	3	5	10	15

Main power pole ratings

Power pole configuration		Electrically held contactor		Mechanically held contactor	
NO	NC	Standard type 1 enclosure	Oversized type 1 enclosure	Standard type 1 enclosure	Oversized type 1 enclosure
2	0	<input type="checkbox"/> CR463L20A*A10A0	<input type="checkbox"/> CR463L20A*A10AA	<input type="checkbox"/> CR463M20###A10A0	<input type="checkbox"/> CR463M20###A10AA
3	0	<input type="checkbox"/> CR463L30A*A10A0	<input type="checkbox"/> CR463L30A*A10AA	<input type="checkbox"/> CR463M30###A10A0	<input type="checkbox"/> CR463M30###A10AA
4	0	<input type="checkbox"/> CR463L40A*A10A0	<input type="checkbox"/> CR463L40A*A10AA	<input type="checkbox"/> CR463M40###A10A0	<input type="checkbox"/> CR463M40###A10AA
6	0	<input type="checkbox"/> CR463L60A*A10A0	<input type="checkbox"/> CR463L60A*A10AA	<input type="checkbox"/> CR463M60###A10A0	<input type="checkbox"/> CR463M60###A10AA
8	0	<input type="checkbox"/> CR463L80A*A10A0	<input type="checkbox"/> CR463L80A*A10AA	<input type="checkbox"/> CR463M80###A10A0	<input type="checkbox"/> CR463M80###A10AA
10	0	<input type="checkbox"/> CR463LB0A*A10A0	<input type="checkbox"/> CR463LB0A*A10AA	<input type="checkbox"/> CR463MB0###A10A0	<input type="checkbox"/> CR463MB0###A10AA
12	0	<input type="checkbox"/> CR463LD0A*A10A0	<input type="checkbox"/> CR463LD0A*A10AA	<input type="checkbox"/> CR463MD0###A10A0	<input type="checkbox"/> CR463MD0###A10AA
---	---	-----	-----	-----	-----

*** 60Hz coil voltage (✓) for electrically held**

24V	115-120V	200-208V	230-240V	277V	460-488V	575-600V
<input type="checkbox"/> C	<input type="checkbox"/> J	<input type="checkbox"/> L	<input type="checkbox"/> S	<input type="checkbox"/> T	<input type="checkbox"/> U	<input type="checkbox"/> Y

Extended description (if any): _____

Control module (✓) for mechanically held

Control volts	2-wire control coil voltage		3-wire control coil voltage	
	115-120V	277V	115-120V	277V
24-48V	<input type="checkbox"/> BJ	<input type="checkbox"/> BN	<input type="checkbox"/> MJ	<input type="checkbox"/> MN
110-120V	<input type="checkbox"/> CJ	<input type="checkbox"/> CN	<input type="checkbox"/> NJ	<input type="checkbox"/> NN
200-277V	<input type="checkbox"/> DJ	<input type="checkbox"/> PN	<input type="checkbox"/> PJ	<input type="checkbox"/> PN

CR460 series lighting contactors - project submittal form

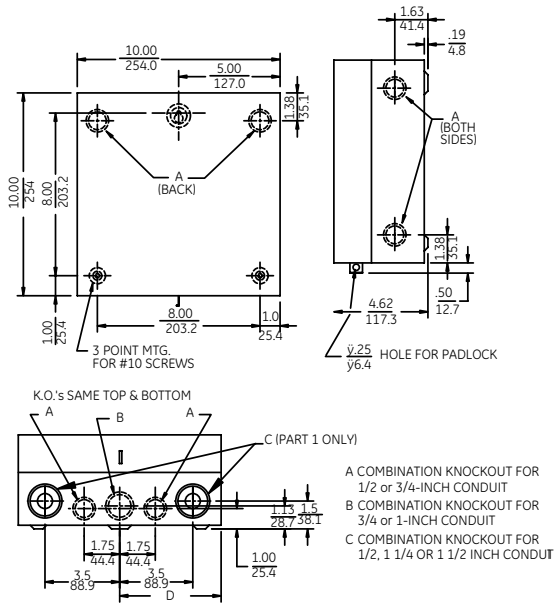

Type 1, standard enclosure

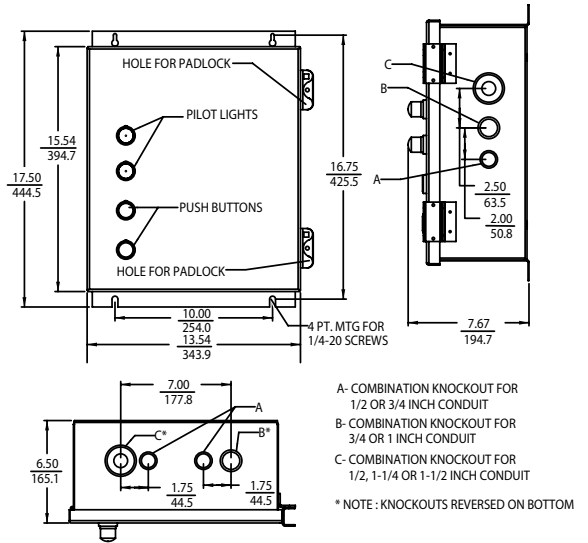

Type 1, oversized enclosure

CR463L

Electrically held contactors
 CR463L -30A (2-12 pole)
 Standard assembled forms



Product number selection instructions

Replace * in the product number with the appropriate digits from the coil voltage table on page 3-15. The resulting product number will be for an assembled contactor with no additional auxiliary contacts, pilot devices, pilot lights, control circuit fuses or CPTs.

For modified assembled forms with those modifications, see pages 3-16 and 3-17.

- Items listed here are the most common pole configurations.
- Poles may be reconfigured by the user into alternative combinations of NO and NC contacts.
- All configurations are available as factory-assembled forms.

Open

No. of poles	Contact configuration	Product number
2	1NO-1NC	CR463L11A*A
2	2NO	CR463L20A*A
3	3NO	CR463L30A*A
4	3NO-1NC	CR463L31A*A
4	4NO	CR463L40A*A
5	5NO	CR463L50A*A
6	5NO-1NC	CR463L51A*A
6	6NO	CR463L60A*A
7	7NO	CR463L70A*A
8	7NO-1NC	CR463L71A*A
8	8NO	CR463L80A*A
9	9NO	CR463L90A*A
10	9NO-1NC	CR463L91A*A
10	10NO	CR463LB0A*A
11	11NO	CR463LC0A*A
12	12NO	CR463LD0A*A

Enclosed NEMA Type 1 surface mount (oversize)¹

No. of poles	Contact configuration	Product number
2	1NO-1NC	CR463L11A*A10AA
2	2NO	CR463L20A*A10AA
3	3NO	CR463L30A*A10AA
4	3NO-1NC	CR463L31A*A10AA
4	4NO	CR463L40A*A10AA
5	5NO	CR463L50A*A10AA
6	5NO-1NC	CR463L51A*A10AA
6	6NO	CR463L60A*A10AA
7	7NO	CR463L70A*A10AA
8	7NO-1NC	CR463L71A*A10AA
8	8NO	CR463L80A*A10AA
9	9NO	CR463L90A*A10AA
10	9NO-1NC	CR463L91A*A10AA
10	10NO	CR463LB0A*A10AA
11	11NO	CR463LC0A*A10AA
12	12NO	CR463LD0A*A10AA

¹Oversize enclosures required for field installed pilot devices, pilot lights and control power transformers.

Enclosed NEMA Type 1 surface mount

No. of poles	Contact configuration	Product number
2	1NO-1NC	CR463L11A*A10A0
2	2NO	CR463L20A*A10A0
3	3NO	CR463L30A*A10A0
4	3NO-1NC	CR463L31A*A10A0
4	4NO	CR463L40A*A10A0
5	5NO	CR463L50A*A10A0
6	5NO-1NC	CR463L51A*A10A0
6	6NO	CR463L60A*A10A0
7	7NO	CR463L70A*A10A0
8	7NO-1NC	CR463L71A*A10A0
8	8NO	CR463L80A*A10A0
9	9NO	CR463L90A*A10A0
10	9NO-1NC	CR463L91A*A10A0
10	10NO	CR463LB0A*A10A0
11	11NO	CR463LC0A*A10A0
12	12NO	CR463LD0A*A10A0

Enclosed NEMA Type 1 surface mount

No. of poles	Contact configuration	Product number
2	1NO-1NC	CR463L11A*A80A0
2	2NO	CR463L20A*A80A0
3	3NO	CR463L30A*A80A0
4	3NO-1NC	CR463L31A*A80A0
4	4NO	CR463L40A*A80A0
5	5NO	CR463L50A*A80A0
6	5NO-1NC	CR463L51A*A80A0
6	6NO	CR463L60A*A80A0
7	7NO	CR463L70A*A80A0
8	7NO-1NC	CR463L71A*A80A0
8	8NO	CR463L80A*A80A0
9	9NO	CR463L90A*A80A0
10	9NO-1NC	CR463L91A*A80A0
10	10NO	CR463LB0A*A80A0
11	11NO	CR463LC0A*A80A0
12	12NO	CR463LD0A*A80A0

CR463L

Electrically held contactors
 CR463L -30A (2-12 pole)
 Standard assembled forms

Enclosed NEMA Type 12/3R

No. of poles	Contact configuration	Product number
2	1NO-1NC	CR463L11A*A20A0
2	2NO	CR463L20A*A20A0
3	3NO	CR463L30A*A20A0
4	3NO-1NC	CR463L31A*A20A0
4	4NO	CR463L40A*A20A0
5	5NO	CR463L50A*A20A0
6	5NO-1NC	CR463L51A*A20A0
6	6NO	CR463L60A*A20A0
7	7NO	CR463L70A*A20A0
8	7NO-1NC	CR463L71A*A20A0
8	8NO	CR463L80A*A20A0
9	9NO	CR463L90A*A20A0
10	9NO-1NC	CR463L91A*A20A0
10	10NO	CR463LB0A*A20A0
11	11NO	CR463LC0A*A20A0
12	12NO	CR463LD0A*A20A0

Enclosed NEMA Type 4/4X

No. of poles	Contact configuration	Product number
2	1NO-1NC	CR463L11A*A40A0
2	2NO	CR463L20A*A40A0
3	3NO	CR463L30A*A40A0
4	3NO-1NC	CR463L31A*A40A0
4	4NO	CR463L40A*A40A0
5	5NO	CR463L50A*A40A0
6	5NO-1NC	CR463L51A*A40A0
6	6NO	CR463L60A*A40A0
7	7NO	CR463L70A*A40A0
8	7NO-1NC	CR463L71A*A40A0
8	8NO	CR463L80A*A40A0
9	9NO	CR463L90A*A40A0
10	9NO-1NC	CR463L91A*A40A0
10	10NO	CR463LB0A*A40A0
11	11NO	CR463LC0A*A40A0
12	12NO	CR463LD0A*A40A0

Enclosed NEMA Type 12/3R (oversize)¹

No. of poles	Contact configuration	Product number
2	1NO-1NC	CR463L11A*A20AA
2	2NO	CR463L20A*A20AA
3	3NO	CR463L30A*A20AA
4	3NO-1NC	CR463L31A*A20AA
4	4NO	CR463L40A*A20AA
5	5NO	CR463L50A*A20AA
6	5NO-1NC	CR463L51A*A20AA
6	6NO	CR463L60A*A20AA
7	7NO	CR463L70A*A20AA
8	7NO-1NC	CR463L71A*A20AA
8	8NO	CR463L80A*A20AA
9	9NO	CR463L90A*A20AA
10	9NO-1NC	CR463L91A*A20AA
10	10NO	CR463LB0A*A20AA
11	11NO	CR463LC0A*A20AA
12	12NO	CR463LD0A*A20AA

Coil voltage

Insert coil digit in place of * in digit 10.

Coil voltage		
AC, 60Hz	AC, 50Hz	Coil digit
24V	20V	C
28V	24V	D
115-120V	110V	J
200-208V	-	L
230-240V	220V	S
277V	240V	N
347V	-	T
460-480V	440V	U
575-600V	550V	Y

¹Oversize enclosures required for field installed pilot devices, pilot lights and control power transformers.

CR463L

Modified assembled forms - electrically held

CR463L Electrically held contactors

Follow the diagram and tables below to select the options and corresponding product number digits for your modified contactor.



1: NO power pole contact configuration

0	7
1	8
2	9
3	10 (B) ¹
4	11 (C) ¹
5	12 (D) ¹
6	

¹For digit 1 with 10 NO contacts use B; for 11 NO contacts, use C; for 12 NO contacts, use D.

2: NC power pole contact configuration

0	4
1	5
2	6
3	7
4	8

3: Standard control

A

4: Coil voltage

AC, 60Hz	AC, 50Hz	Digit 4
24V	20V	C
28V	24V	D
115-120V	110V	J
200-208V	-	L
230-240V	220V	S
277V	240V	N
347V	-	T
460-480V	440V	U
575-600V	550V	Y

5: Additional auxiliary contacts

Additional (field use) auxiliary contacts	Digit 5 (aux)	Open type	Enclosed with pilot device codes (Digit 7) 0, 2, 4, 5, 6, 7, 8 below				Enclosed with pilot device codes (Digit 7) 1, 3 below			
			No pilot devices or pilot lights Digit 8=A	ON light across coil Digit 8=B,D	OFF light thru NC contact Digit 8=C,E	ON light across coil and OFF light thru NC contact Digit 8=F,G	No pilot devices or pilot lights Digit 8=A	ON light across coil Digit 8=B,D	OFF light thru NC contact Digit 8=C,E	ON light across coil and OFF light thru NC contact Digit 8=F,G
None	A	•	•	•	•	•	•	•	•	•
1NO	B	•	•	•	•	•	•	•	•	•
1NC	C	•	•	•	•	•	•	•	•	•
1NO-1NC	D	•	•	•	•	•	•	•	•	•
2NO	E	•	•	•	•	-	-	-	-	-
2NO-1NC	F	•	•	•	•	-	-	-	-	-
2NC	G	•	•	•	-	-	•	•	-	-
1NO-2NC	H	•	•	•	-	-	•	•	-	-
2NO-2NC	J	•	•	•	-	-	-	-	-	-

Each side of the contactor base will accept one single- or double-pole auxiliary contact block, for a maximum of 2NO-2NC contacts. Enclosures with OFF pilot lights require 1NC contact. Specify an additional 1NO contact if a holding interlock is required and "not" selected as part of Digit 7 (1 or 3). For open forms, this is the final digit.

CR463L

Modified assembled forms - electrically held (continued)

CR463L Electrically held contactors

Follow the diagram and tables below to select the options and corresponding product number digits for your modified contactor.



6: Enclosures

Enclosure type	Digit 6
Type 1 surface for 2 pole contactors	1
Type 1 surface for 5-12 pole contactors	1
Type 1 flush	8
Type 12/3R	2
Type 4/4X	4

7: Pilot devices

Pilot device	Holding interlock		Digit 7
	Not required	Included ²	
None	-	-	0
ON/OFF push button (momentary)	-	•	1
ON/OFF selector switch (maintained)	•	-	2
ON/OFF selector switch, spring return to center (momentary)	-	•	3
H-O-A selector switch (maintained)	•	-	4
ON/OFF/AUTO keyed selector switch (removal all positions) (maintained)	•	-	5
H-O-A keyed selector switch (removal all positions) (maintained)	•	-	6
OFF/AUTO selector switch (maintained)	•	-	7
ON/OFF/AUTO selector switch (maintained)	•	-	8

²One holding interlock is included in pilot device digit and pricing.

Heavy-duty, 30mm pilot devices. Contactor supplied in oversize enclosures with these options. Not available in Type 1 flush enclosure.

8: Pilot lights

Type	Pilot light(s)	Digit 8
-	None	A
Standard ³	ON	B
	OFF	C
	ON and OFF	F
Push-to-test ³	ON	D
	OFF	E
	ON and OFF	G

³ON is across coil; OFF is through NC contact, which is included in pilot light digit and pricing.

Heavy-duty 30mm pilot lights with interchangeable red and green lenses. See the additional auxiliary contacts table above for contact limitations. OFF light includes extra auxiliary contact. Not available in Type 1 flush enclosure.

9: Control circuit fuses/control power transformers

Contactor type	Description	Digit 9
-	None	0
Without CPT	Control circuit fuses	1
	CPT primary volts	
	208	
	220-240	
	277	
	440-480	
With 100VA CPT ⁴	CPT secondary volts	24
	120	
	208	
	220-240	
	277	
	440-480	
	600	
	600	

⁴Contactor supplied in oversize enclosure with these options.

CR463M

Mechanically held contactors
 CR463M - 30A (2-12 pole)
 Standard assembled forms

Product number selection instructions

To specify control and coil voltage, replace ** in the product number with the appropriate digits from the control circuit table. The resulting product number will be for an assembled contactor with no additional auxiliary contacts, pilot devices, pilot lights, control circuit fuses or CPTs. If coil supply voltage is greater than 277V, use a CPT.

For modified assembled forms with those modifications, see pages 3-15 and 3-16. Items listed here are the most common pole configurations.

Open

No. of poles	Contact configuration	Product number
2	1NO-1NC	CR463M11**A
2	2NO	CR463M20**A
3	3NO	CR463M30**A
4	3NO-1NC	CR463M31**A
4	4NO	CR463M40**A
5	5NO	CR463M50**A
6	5NO-1NC	CR463M51**A
6	6NO	CR463M60**A
7	7NO	CR463M70**A
8	7NO-1NC	CR463M71**A
8	8NO	CR463M80**A
9	9NO	CR463M90**A
10	9NO-1NC	CR463M91**A
10	10NO	CR463MB0**A
11	11NO	CR463MC0**A
12	12NO	CR463MD0**A

Enclosed NEMA Type 1 surface mount

No. of poles	Contact configuration	Product number
2	1NO-1NC	CR463M11**A10A0
2	2NO	CR463M20**A10A0
3	3NO	CR463M30**A10A0
4	3NO-1NC	CR463M31**A10A0
4	4NO	CR463M40**A10A0
5	5NO	CR463M50**A10A0
6	5NO-1NC	CR463M51**A10A0
6	6NO	CR463M60**A10A0
7	7NO	CR463M70**A10A0
8	7NO-1NC	CR463M71**A10A0
8	8NO	CR463M80**A10A0
9	9NO	CR463M90**A10A0
10	9NO-1NC	CR463M91**A10A0
10	10NO	CR463MB0**A10A0
11	11NO	CR463MC0**A10A0
12	12NO	CR463MD0**A10A0

Enclosed NEMA Type 1 surface mount (oversize)¹

No. of poles	Contact configuration	Product number
2	1NO-1NC	CR463M11**A10AA
2	2NO	CR463M20**A10AA
3	3NO	CR463M30**A10AA
4	3NO-1NC	CR463M31**A10AA
4	4NO	CR463M40**A10AA
5	5NO	CR463M50**A10AA
6	5NO-1NC	CR463M51**A10AA
6	6NO	CR463M60**A10AA
7	7NO	CR463M70**A10AA
8	7NO-1NC	CR463M71**A10AA
8	8NO	CR463M80**A10AA
9	9NO	CR463M90**A10AA
10	9NO-1NC	CR463M91**A10AA
10	10NO	CR463MB0**A10AA
11	11NO	CR463MC0**A10AA
12	12NO	CR463MD0**A10AA

¹Oversize enclosures required for field installed pilot devices, pilot lights and control power transformers.

Enclosed NEMA Type 1 flush mount

No. of poles	Contact configuration	Product number
2	1NO-1NC	CR463M11**A80A0
2	2NO	CR463M20**A80A0
3	3NO	CR463M30**A80A0
4	3NO-1NC	CR463M31**A80A0
4	4NO	CR463M40**A80A0
5	5NO	CR463M50**A80A0
6	5NO-1NC	CR463M51**A80A0
6	6NO	CR463M60**A80A0
7	7NO	CR463M70**A80A0
8	7NO-1NC	CR463M71**A80A0
8	8NO	CR463M80**A80A0
9	9NO	CR463M90**A80A0
10	9NO-1NC	CR463M91**A80A0
10	10NO	CR463MB0**A80A0
11	11NO	CR463MC0**A80A0
12	12NO	CR463MD0**A80A0

Insert control circuit rating digits in place of the ** in digit 9 and 10 of product number.

Control circuit rating

Product no. digits by coil voltage (60Hz) ²			
Control	Control module input	115-120 Vac	277 Vac
2 wire	110-120 Vac	CJ	CN
	200-277 Vac	DJ	DN
3 wire	110-120 Vac	NJ	NN
	200-277 Vac	PJ	PN

²For 50Hz coil ratings see coil table, page 3-9.

CR463M

Mechanically held contactors
 CR463M - 30A (2-12 pole)
 Standard assembled forms

Enclosed NEMA Type 12/3R

No. of poles	Contact configuration	Product number
2	1NO-1NC	CR463M11**A20A0
2	2NO	CR463M20**A20A0
3	3NO	CR463M30**A20A0
4	3NO-1NC	CR463M31**A20A0
4	4NO	CR463M40**A20A0
5	5NO	CR463M50**A20A0
6	5NO-1NC	CR463M51**A20A0
6	6NO	CR463M60**A20A0
7	7NO	CR463M70**A20A0
8	7NO-1NC	CR463M71**A20A0
8	8NO	CR463M80**A20A0
9	9NO	CR463M90**A20A0
10	9NO-1NC	CR463M91**A20A0
10	10NO	CR463MB0**A20A0
11	11NO	CR463MC0**A20A0
12	12NO	CR463MD0**A20A0

Enclosed NEMA Type 4/4X

No. of poles	Contact configuration	Product number
2	1NO-1NC	CR463M11**A40A0
2	2NO	CR463M20**A40A0
3	3NO	CR463M30**A40A0
4	3NO-1NC	CR463M31**A40A0
4	4NO	CR463M40**A40A0
5	5NO	CR463M50**A40A0
6	5NO-1NC	CR463M51**A40A0
6	6NO	CR463M60**A40A0
7	7NO	CR463M70**A40A0
8	7NO-1NC	CR463M71**A40A0
8	8NO	CR463M80**A40A0
9	9NO	CR463M90**A40A0
10	9NO-1NC	CR463M91**A40A0
10	10NO	CR463MB0**A40A0
11	11NO	CR463MC0**A40A0
12	12NO	CR463MD0**A40A0

Enclosed NEMA Type 12/3R (oversize)¹

No. of poles	Contact configuration	Product number
2	1NO-1NC	CR463M11**A20AA
2	2NO	CR463M20**A20AA
3	3NO	CR463M30**A20AA
4	3NO-1NC	CR463M31**A20AA
4	4NO	CR463M40**A20AA
5	5NO	CR463M50**A20AA
6	5NO-1NC	CR463M51**A20AA
6	6NO	CR463M60**A20AA
7	7NO	CR463M70**A20AA
8	7NO-1NC	CR463M71**A20AA
8	8NO	CR463M80**A20AA
9	9NO	CR463M90**A20AA
10	9NO-1NC	CR463M91**A20
10	10NO	CR463MB0**A20AA
11	11NO	CR463MC0**A20AA
12	12NO	CR463MD0**A20AA

Insert control circuit rating digits in place of the ** in digit 9 and 10 of product number.

Control circuit rating

Product no. digits by coil voltage (60Hz) ²			
Control	Control module input	115-120 Vac	277 Vac
2 wire	110-120 Vac	CJ	CN
	200-277 Vac	DJ	DN
3 wire	110-120 Vac	NJ	NN
	200-277 Vac	PJ	PN

¹Oversize enclosures required for field installed pilot devices, pilot lights and control power transformers.

²For 50Hz coil ratings see coil table, page 3-9.

CR463M

Modified assembled forms - mechanically held

CR463M Mechanically held contactors

Follow the diagram and tables below to select the options and corresponding product number digits for your modified contactor.



1: NO power pole contact configuration

0	7
1	8
2	9
3	10 (B) ¹
4	11 (C) ¹
5	12 (D) ¹
6	

¹For digit 1 with 10 NO contacts use B; for 11 NO contacts, use C; for 12 NO contacts, use D.

2: NC power pole contact configuration

0	4
1	5
2	6
3	7
4	8

3 & 4: Control circuit

Control	Control module input	Digits 3 & 4 by coil voltage (60Hz) ²				
		24 VAC	115-120 VAC	200-208 VAC	230-240 VAC	277 VAC
2 wire	24 VAC	BC	BJ	BL	BS	BN
	110-120 VAC	CC	CJ	CL	CS	CN
	200-277 VAC	DC	DJ	DL	DS	DN
	12-28 VDC	EC	EJ	EL	ES	EN
3 wire	24 VAC	MC	MJ	ML	MS	MN
	110-120 VAC	NC	NJ	NL	NS	NN
	200-277 VAC	PC	PJ	PL	PS	PN
	12-28 VDC	RC	RJ	RL	RS	RN

²For 50Hz coil ratings see coil table, page 3-9.

If coil supply voltage is greater than 277V, use CPT.

5: Additional auxiliary contacts

Additional (field use) auxiliary contacts	Digit 5	2-wire control (when Digit 3 = B, C, D, E)					3-wire control (when Digit 3 = M, N, P, R)				
		Open type	Enclosed (when Digit 7 = 0, 2, 4, 5, 6, 7, 8)				Open type	Enclosed (when Digit 7 = 1, 2, 3)			
			No pilot lights Digit 8=A	ON light thru NO contact Digit 8=B,D	OFF light thru NC contact Digit 8=C,E	ON light thru NO contact and OFF light thru NC contact Digit 8=F,G		No pilot devices or pilot lights Digit 8=A	ON light thru NO contact Digit 8=B,D	OFF light thru NC contact Digit 8=C,E	ON light thru NO contact and OFF light thru NC contact Digit 8=F,G
None	A	•	•	•	•	•	•	•	•	•	
1NO	B	•	•	•	•	•	•	-	•	-	
1NC	C	•	•	•	-	•	•	-	-	-	
1NO-1NC	D	•	•	•	-	•	•	-	-	-	
2NO	E	•	•	-	•	-	-	-	-	-	

Each side of the contactor base will accept one single- or double-pole auxiliary contact block, for a maximum of 2NO-2NC contacts. The 2-wire control module uses 1NC contact and the 3-wire uses 1NO-1NC for feedback and control. The table above indicates the additional auxiliary contacts available for customer or field use when factory-assembled forms are supplied. For open forms, this is the final digit.

CR463M

Modified assembled forms - mechanically held (continued)

CR463M Mechanically held contactors

Follow the diagram and tables below to select the options and corresponding product number digits for your modified contactor.



6: Enclosures

Enclosure type	Digit 6
Type 1 surface for 2-4 pole contactors	1
Type 1 surface for 5-12 pole contactors	1
Type 1 flush	8
Type 12/3R	2
Type 4/4X	4

7: Pilot devices

Pilot device	Control module		Digit 7
	2-wire	3 wire	
None	-	-	0
ON/OFF push button (momentary)	-	•	1
ON/OFF selector switch (maintained)	•	•	2
ON/OFF selector switch, spring return to center (momentary)	-	•	3
H-O-A selector switch (maintained)	•	-	4
ON/OFF/AUTO keyed selector switch (removal all positions) (maintained)	•	-	5
H-O-A keyed selector switch (removal all positions) (maintained)	•	-	6
OFF/AUTO selector switch (maintained)	•	-	7
ON/OFF/AUTO selector switch (maintained)	•	-	8

Heavy-duty, 30mm pilot devices. Oversize enclosure required for field installed pilot devices, pilot lights and control power transformers. Not available in Type 1 flush enclosure.

8: Pilot lights

Type	Pilot light(s) ³	Digit 8
-	None	A
Standard	ON	B
	OFF	C
	ON and OFF	F
Push-to-test	ON	D
	OFF	E
	ON and OFF	G

³Contactors supplied in oversize enclosure with these options. ON is through NO contact; OFF is through NC contact. Auxiliary contacts are included in pilot light digit.

Heavy-duty 30mm pilot lights with interchangeable red and green lenses. See the additional auxiliary contacts table above for contact limitations. OFF light includes extra auxiliary contact. Not available in Type 1 flush enclosure.

9: Control circuit fuses/control power transformers

Contactor type	Description	Digit 9
-	None	0
Without CPT	Control circuit fuses	1
	CPT primary volts	
	208	
	220-240	
	277	
	440-480	
With 100VA CPT ⁴	CPT secondary volts	24
	120	
	208	
	220-240	
	277	
	440-480	
	600	

⁴Oversize enclosure required for field installed pilot devices, pilot lights and control power transformers.

CPT secondary voltage must match control voltage. Not available in Type 1 flush enclosure.

CR460, CR463

Technical data

Main power pole ratings

Maximum AC voltage and amp ratings

Load type	Amps continuous	Poles	
		1 phase	3 phase
Ballast	30	347 VAC	600 VAC
Tungsten	20	277 VAC	480 VAC
General use/AC resistive	30	600 VAC	600 VAC
LED driver/ Electronic ballast	10	120 Vac	-
	3	277 Vac	-

Maximum horsepower rating (normal starting duty)

	1 pole, single phase			3 poles, three phase		
Volts	110-120V	220-240V	200-208V	220-240V	440-480V	550-600V
HP	1	2	3	5	10	15

Short circuit current ratings

For 463 series contactors available amps (RMS) symmetrical

Circuit breakers inverse trip type	Enclosure type CR460X*B			Enclosure type CR460X*D or larger			
	AC service voltage	Breaker size	TEY/ THHQB	All other inverse trip breakers	THHQB	TEY	SE
240	30	22,000	14,000	22,000	65,000	100,000	22,000
	40	14,000	10,000	22,000	65,000	100,000	22,000
277	30	14,000 ¹	10,000	N/A	14,000	30,000	14,000
	40	14,000 ¹	5,000	N/A	14,000	30,000	14,000
480	40	N/A	5,000	N/A	N/A	30,000	14,000
600	40	N/A	5,000	N/A	N/A	14,000	10,000

¹TEY only

Withstand current ratings

For 463 series contactors - available amps (RMS) symmetrical fuses

AC service voltage	Fuse size	Enclosure type CR460X*B		Enclosure type CR460X*D or larger		
		Fuse type J	RK1	Fuse type J/ RK1/RKS	K	H
600 and below	30	100,000	50,000	100,000	50,000	10,000

Control circuit characteristics

Coil

Inrush	340 VA
Sealed	45 VA

Control module

Input voltage	Steady state current @ rated voltage (mA)	Maximum VA
12-28 VDC	42	2
24 VAC	80	5
115-120 VAC	83	12
200-277 VAC	91	30

Minimum pulse duration (3-wire control module)	250ms
Maximum allowable leakage current	1.8mA
EMI	35V/m
Surge transient peak	6kV
Frequency range	40-70Hz

Auxiliary contacts rating

A600, 10A, 600 VAC

Wire size ratings

Component	Number of cables	Wire range (AWG) (Solid or stranded)	Wire temp.
Power poles	1	#14-8	75°C Cu
Power poles	2	#14-8 ²	75°C Cu
Coil	1 or 2	#18-14	60°/75°C Cu
Control module	1 or 2	#22-12	60°/75°C Cu
Auxiliary contacts	1 or 2	#22-12	60°/75°C Cu

²#8 AWG stranded only.

Standards and listings

UL508 file, E1811 Vol 19, cUL, CE

Ambient operating temperature

-25° to 40°C

Reference publications

Instructions	DEH-40460
--------------	-----------

Wiring diagrams

Wiring diagrams and outline drawings	Reference page
CR463L electrically held	3-23
CR463M mechanically held	3-23
55-217114P01	3-24
55-217069 (CR460XE1B)	3-25
55-217105 (CR460XE1D)	3-25
55-217108 (CR460XE8B)	3-25
55-217109 (CR460XE2B)	3-26
55-217106 (CR460XE2D)	3-26
55-217107 (CR460XE4D)	3-26

CR463L, CR463M
Wiring diagrams

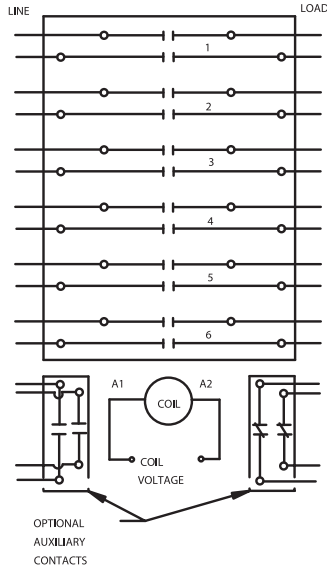

CR463L Electrically held

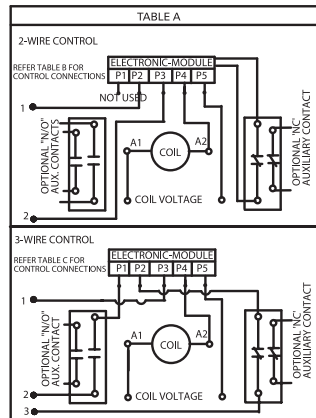
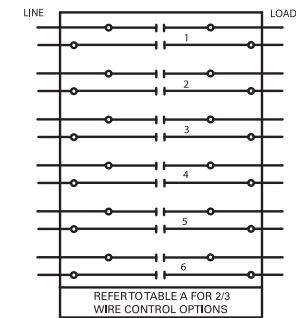
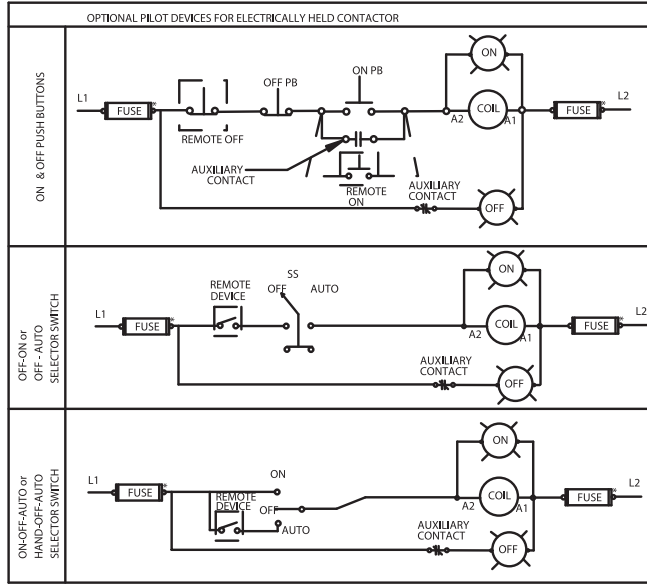

CR463M Mechanically held

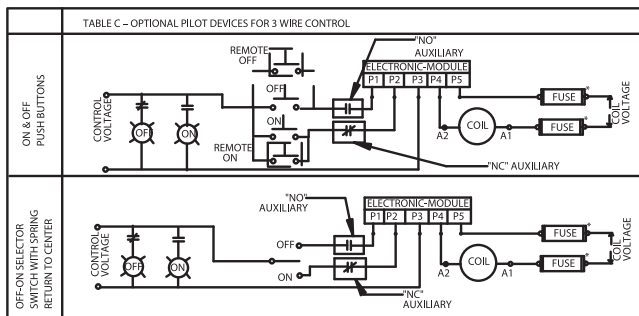
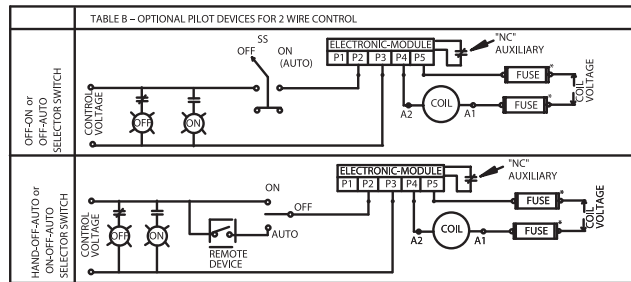

CR463L, CR463M

Outlines and dimensions ($\frac{\text{in.}}{\text{mm}}$) for estimating only

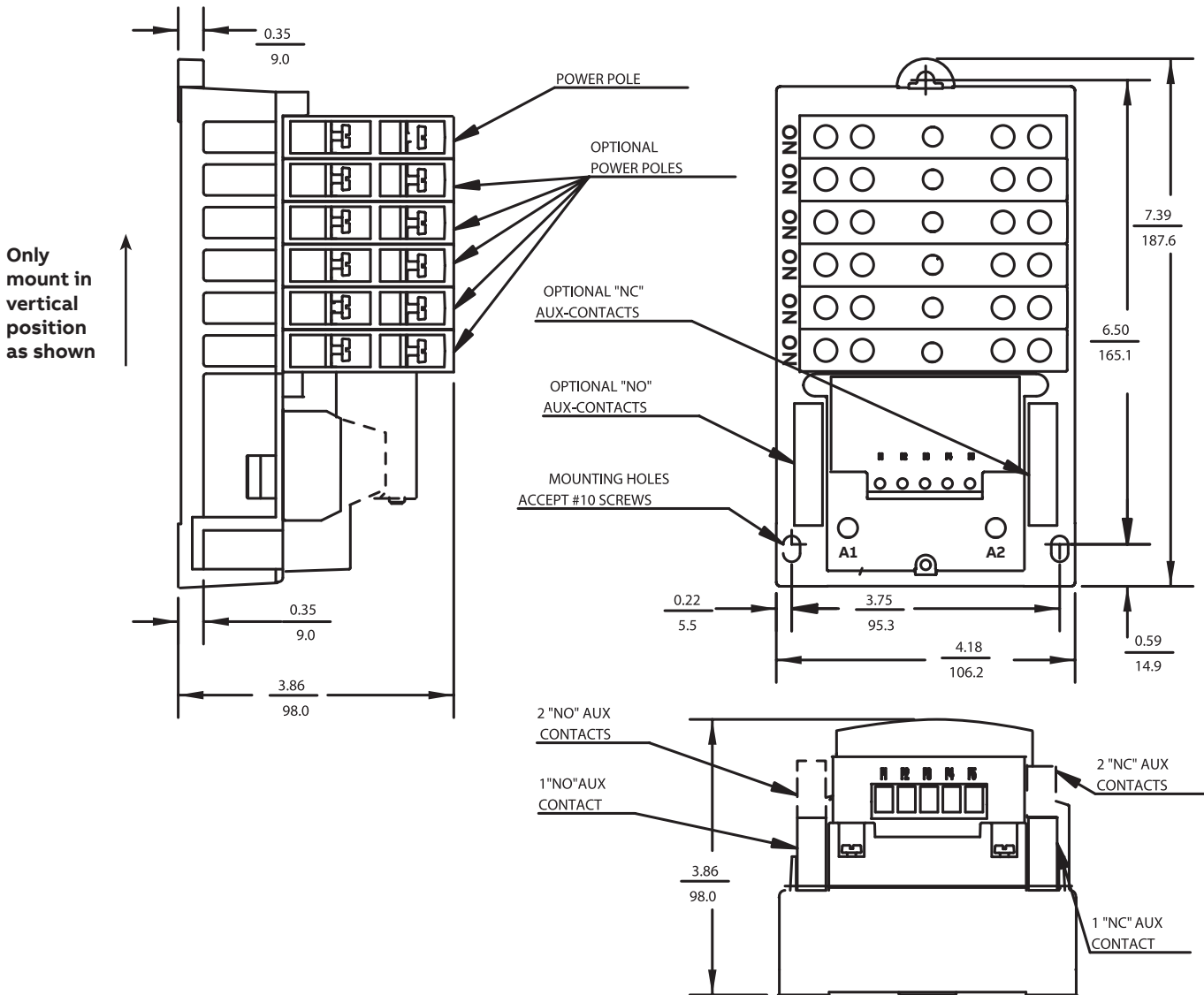

Contactor CR463L and CR463M, drawing #55-217114P01

Features:

1. Mounting dimensions remain the same for 1 to 12 poles
2. Line and load terminals are interchangeable
3. Up to 2NO and 2NC auxiliary contacts can be added onto the base product
4. Same power pole can be configured as NO type or NC tpe in pole positions 1-4; NO type only in positions 5-6.

CR463L, CR463M

Outlines and dimensions ($\frac{\text{in.}}{\text{mm}}$) for estimating only

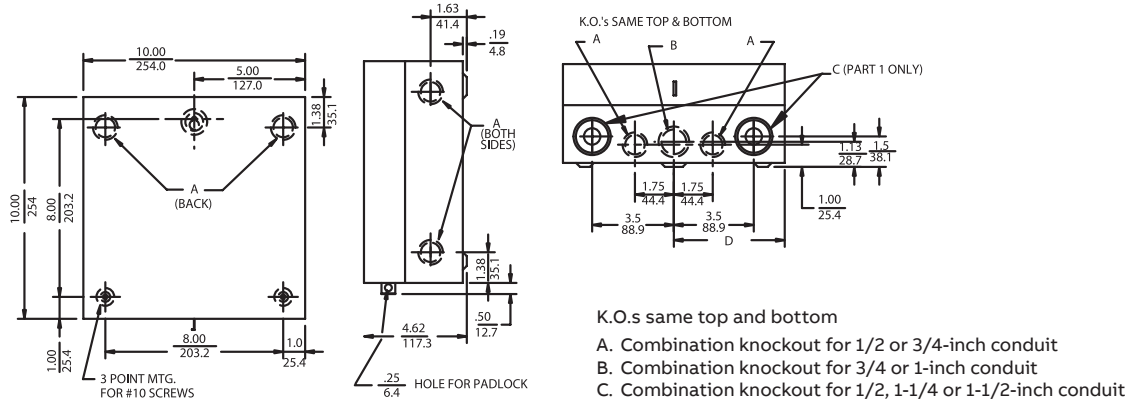

NEMA Type 1 with no CPT, pilot devices or pilot lights, drawing #55-217069 (CR460XE1B)

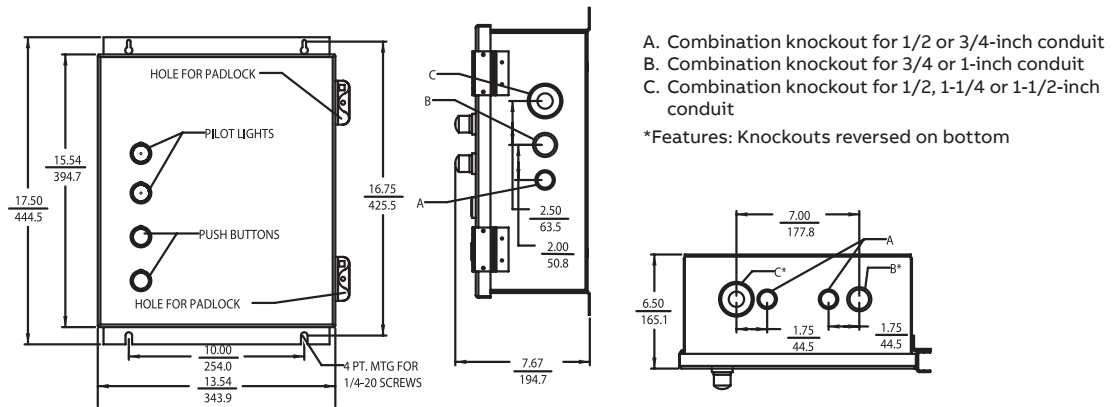

NEMA Type 1 oversized or with provision for CPT and/or pilot device/pilot lights, drawing #55-217105 (CR460XE1D)

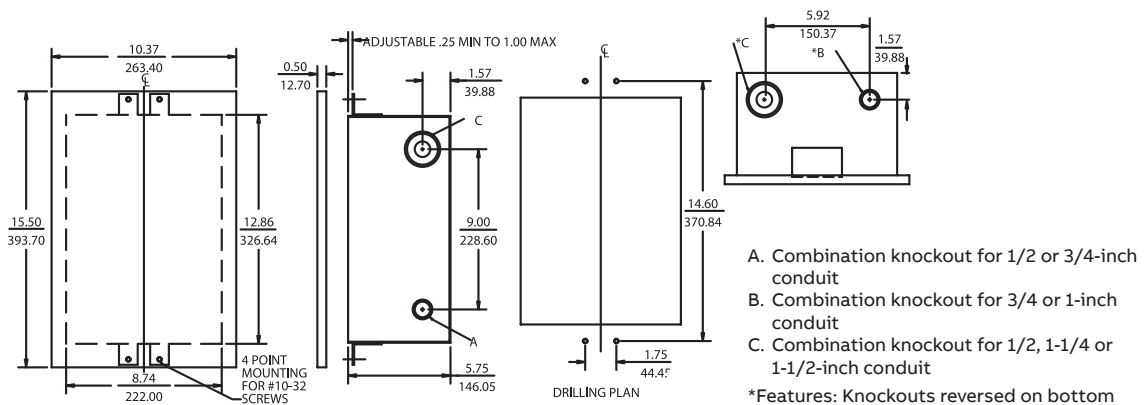

NEMA Type 1 flush, drawing #55-217108 (CR460XE8B)

CR463L, CR463M

Outlines and dimensions ($\frac{\text{in.}}{\text{mm}}$) for estimating only

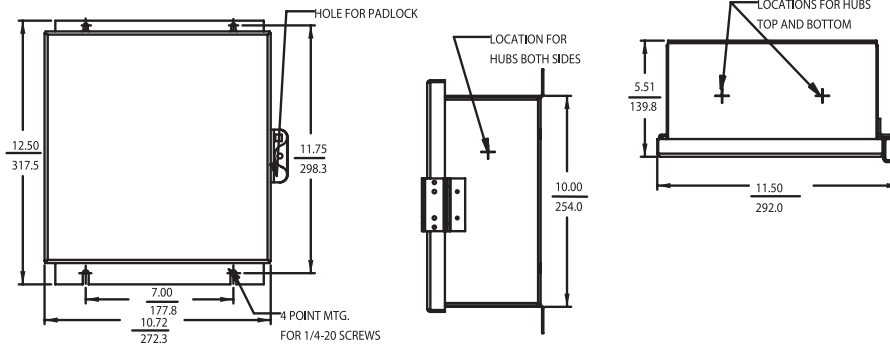

NEMA Type 12/3R with no CPT, pilot device or pilot lights, drawing #55-217109 (CR460XE2B)

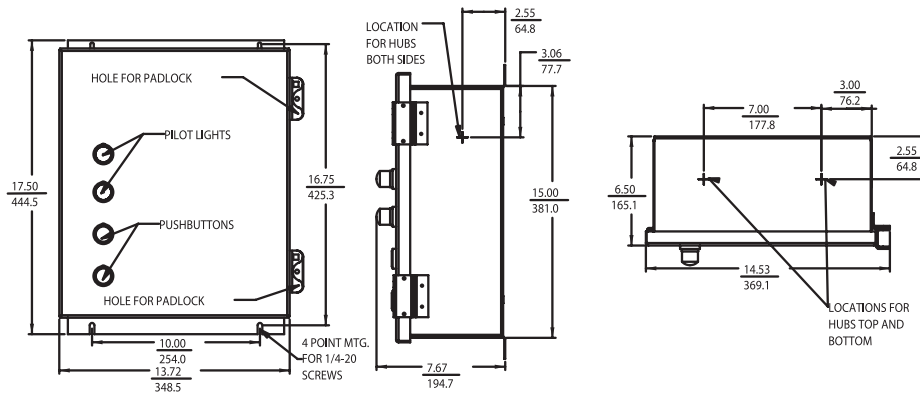

NEMA Type 12/3R oversized with provision for CPT and/or pilot device/pilot lights, drawing #55-217106 (CR460XE2D)

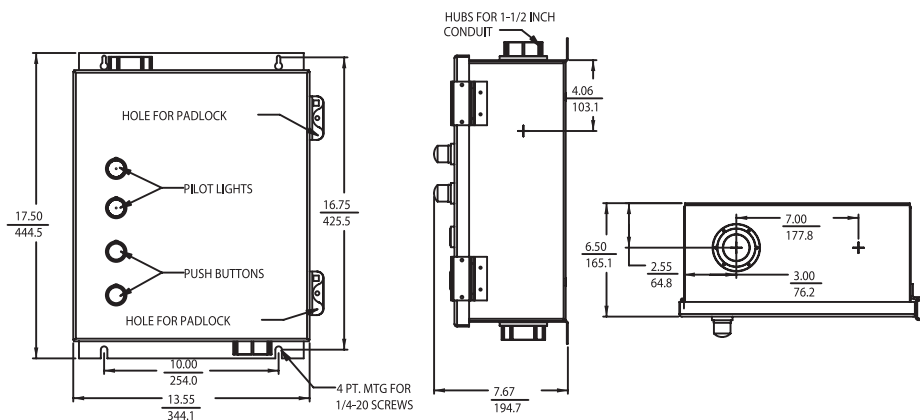

NEMA Type 4/4X oversized with provision for CPT and/or pilot devices/pilot lights, drawing #55-217107 (CR460XE4D)

CR360L

Electrically held contactors

CR360L - 30A - 300A (2, 3 & 4 pole)



Open 60-amp electrically held lighting contactor

Application information

ABB's CR360L series lighting contactors are electrically held, and offer solutions for applications between 30 and 300 amps. This is accomplished in five frame sizes, all built on the successful, and long established NEMA starters. The ratings are established for fluorescent, mercury arc, tungsten and sodium lamp loads, covering a wide spectrum of industrial and commercial applications.

The CR360L contactors offer a wide range of features that include:

- NEMA Type 1, Type 12, Type 3R, and Type 4 stainless steel enclosures
- A full selection of pilot devices, including pushbuttons, selector switches, and multi-colored indicating lights wired in needed configurations
- Main contactors with 2, 3 and 4 power poles
- Generous offering of auxiliary contacts
- Complete list of renewal parts for field installation
- Stock or quick delivery on the majority of products
- UL listing and CSA certification
- Order by complete product number
- Coils will be connected line-to-line unless otherwise specified
- Complete product number must contain 15 digits

CR360L

Electrically held contactors

CR360L - 30A - 300A (2, 3 & 4 pole) (continued)



1: Select size, number of poles, and enclosure

Open

Continuous amp rating	No. of poles	Product number
30A	2	CR360L302
30A	3	CR360L303
30A	4	CR360L304
60A	2	CR360L402
60A	3	CR360L403
60A	4	CR360L404
100A	2	CR360L502
100A	3	CR360L503
100A	4	CR360L504
200A	2	CR360L602
200A	3	CR360L603
200A	4	CR360L604
300A	2	CR360L702
300A	3	CR360L703
300A	4	CR360L704

Enclosed NEMA Type 1

Continuous amp rating	No. of poles	Product number
30A	2	CR360L312
30A	3	CR360L313
30A	4	CR360L314
60A	2	CR360L412
60A	3	CR360L413
60A	4	CR360L414
100A	2	CR360L512
100A	3	CR360L513
100A	4	CR360L514
200A	2	CR360L612
200A	3	CR360L613
200A	4	CR360L614
300A	2	CR360L712
300A	3	CR360L713
300A	4	CR360L714

Enclosed NEMA Type 12

Continuous amp rating	No. of poles	Product number
30A	2	CR360L322
30A	3	CR360L323
30A	4	CR360L324
60A	2	CR360L422
60A	3	CR360L423
60A	4	CR360L424
100A	2	CR360L522
100A	3	CR360L523
100A	4	CR360L524
200A	2	CR360L622
200A	3	CR360L623
200A	4	CR360L624
300A	2	CR360L722
300A	3	CR360L723
300A	4	CR360L724

Enclosed NEMA Type 3R

Continuous amp rating	No. of poles	Product number
30A	2	CR360L362
30A	3	CR360L363
30A	4	CR360L364
60A	2	CR360L462
60A	3	CR360L463
60A	4	CR360L464
100A	2	CR360L562
100A	3	CR360L563
100A	4	CR360L564
200A	2	CR360L662
200A	3	CR360L663
200A	4	CR360L664
300A	2	CR360L762
300A	3	CR360L763
300A	4	CR360L764

Enclosed NEMA Type 4, SS

Continuous amp rating	No. of poles	Product number
30A	2	CR360L322
30A	3	CR360L323
30A	4	CR360L324
60A	2	CR360L422
60A	3	CR360L423
60A	4	CR360L424
100A	2	CR360L522
100A	3	CR360L523
100A	4	CR360L524
200A	2	CR360L622
200A	3	CR360L623
200A	4	CR360L624
300A	2	CR360L722
300A	3	CR360L723
300A	4	CR360L724

CR360L

Electrically held contactors

CR360L - 30A - 300A (2, 3 & 4 pole) (continued)



2: Select coil voltage and control circuit type (following available only with enclosure)

Continuous ampere rating						
Control circuit options	Coil voltage	30A	60A	100A	200A	300A
		Product number digits	Product number digits	Product number digits	Product number digits	Product number digits
None	24	24A	24A	24A	24A	24A
	120	02A	02A	02A	02A	02A
	208 ¹	23A	23A	23A	23A	23A
	240 ¹	03A	03A	03A	03A	03A
	277 ¹	13A	13A	13A	13A	13A
	480 ¹	04A	04A	04A	04A	04A
2 control circuit fuses	24	24D	24D	24D	24D	24D
	120	02D	02D	02D	02D	02D
	208	23D	23D	23D	23D	23D
	240	03D	03D	03D	03D	03D
	277	13D	13D	13D	13D	13D
	480	04D	04D	04D	04D	04D
CPT w/ 120V secondary, includes 2 primary, 1 secondary fuse	CPT primary volts					
	208	82T	82T	62T	48T	40T
	240	03T	03T	03T	03T	03T
	277	61T	61T	61T	61T	61T
	480	04T	04T	04T	04T	04T

¹Control circuit fuses required for 200 and 300 amp forms if pilot devices selected in steps 3 or 4.

3: Select push buttons or selector switch

Push button, selector switch options	NEMA Type 1 only standard-duty	Any enclosure heavy-duty
	Product no. digit	Product no. digit
None	A	A
On-off push button	C ²	K
Hand-off-auto selector switch	D	L
Off-on selector switch	E	M
Hand-off-auto selector switch with key	-	N
On-off-auto selector switch	F	P

²Add holding interlock with this modification

5: Select auxiliary contacts

	Product no. digit
None	Z
Holding interlock	A
Holding interlock plus 1NO	B
Holding interlock plus 1NC	C
Holding interlock plus 1NO, 1NC	D
Holding interlock plus 2NO	E
Holding interlock plus 2NC	F
Holding interlock plus 2NO, 1NC	G

4: Select indicating lights

Light option	NEMA Type 1 only standard-duty	Any enclosure heavy-duty
	Product no. digit	Product no. digit
None	A	A
Red across coil	B	J
Green across coil	-	K

CR360L

Electrically held contactors

CR360L - 30A - 300A (2, 3 & 4 pole)

Technical data

For your convenience, examples of possible wiring schemes are provided on this page. Please review the ratings tables below and use the quick step-by-step selection guide provided, to choose the exact product required for your application.

Ratings

Open or enclosed ratings are 30-, 60-, 100-, 200-, and 300-ampere, ac full-load current.

Maximum AC voltage rating

Lighting load	Line	Load
Tungsten	480	480
Ballast: fluorescent, mercury, sodium, e.g.	600	600

DC tungsten rating

Contactor size, continuous ampere rating	No. poles in series for:	
	125V maximum	250V maximum
30	2	3
60	2	4
100-300	2	2

Reference publications

Instructions

Continuous ampere rating	CR360L contactors
30	GEH-5099
60	GEH-5100
100	GEH-5101
200	GEH-5102
300	GEH-5103

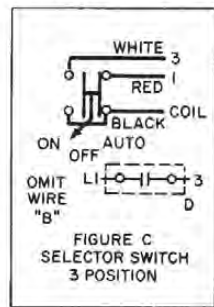
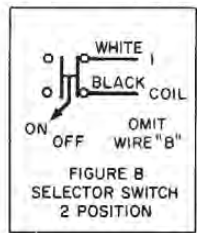
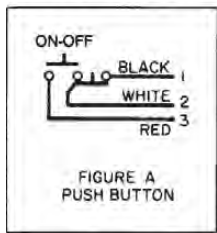
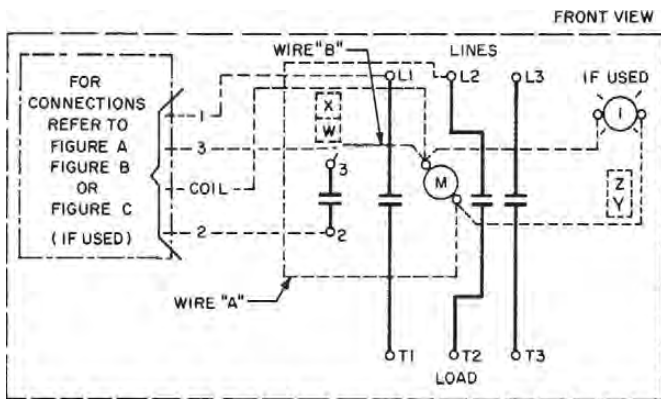

M - LINE CONTACTOR
 I - INDICATING LIGHT
 D - MAINTAINING CONTACT PILOT DEVICE

Typical schematic diagram for CR360L lighting contactor

CR360L

Electrically held contactors

Outlines, dimensions in.(mm) and weights (for estimating only)

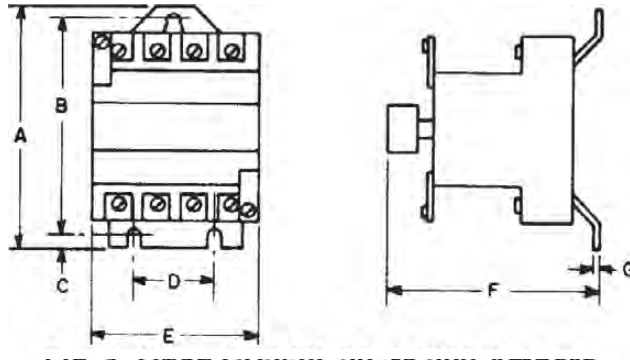

Fig. 1, Open CR360L 30- to 300-ampere, 2- and 3-pole forms

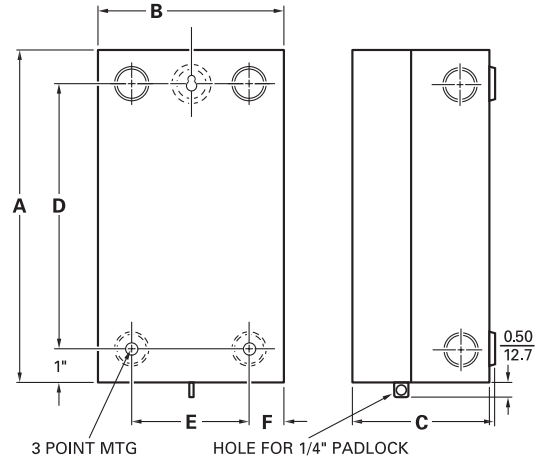

Fig. 2, Enclosed CR360L Type 1, 30-100A w/ standard pilot devices

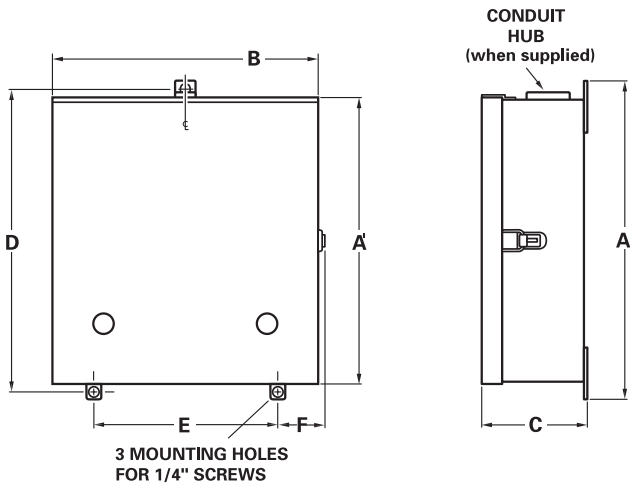

Fig. 3, Enclosed CR360L Type 12, 3R, 4/4X 3-point mounting

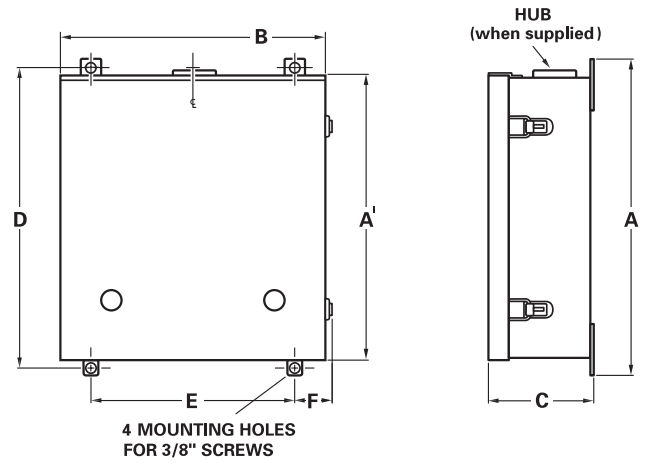

Fig. 4, Enclosed CR360L Type 1, 12, 3R, 4/4X 4-point mounting

Open CR360L - 30A - 300A (2, 3 & 4 pole)

Product number	Figure no.	Dimension in.(mm)							Approx. shipping wt. (lbs)
		A	B	C	D	E	F	G	
CR360L302	1	4.50 (114.3)	4.00 (101.6)	0.25 (6.4)	1.50 (38.1)	3.06 (77.7)	3.81 (96.7)	0.06 (1.5)	2.8
CR360L402	1	6.63 (168.4)	6.00 (152.4)	0.31 (7.8)	2.00 (50.8)	3.75 (95.2)	5.38 (136.6)	0.09 (2.2)	7
CR360L502	1	8.75 (222.2)	7.75 (196.8)	0.63 (16.0)	4.50 (114.3)	5.75 (146.0)	6.50 (165.1)	-	17.5
CR360L602	1	12.00 (304.8)	10.88 (276.4)	0.63 (16.0)	3.00 (76.2)	11.50 (292.1)	9.00 (228.6)	0.12 (3.0)	48
CR360L702	1	12.00 (304.8)	10.88 (276.4)	0.63 (16.0)	3.00 (76.2)	11.50 (292.1)	9.00 (228.6)	0.12 (3.0)	50

CR360L

Electrically held contactors

Outlines, dimensions in.(mm) and weights (for estimating only)

Enclosed CR360L NEMA Type 1

Device	Fig. no.	Hub size	Dimension in.(mm)							Approx. shipping wt. (lbs)
			A	A'	B	C	D	E	F	
(30A) w/o CPT	2	-	10 (254)	-	6 (152.4)	4.63 (117.6)	8 (203.2)	4 (101.6)	1 (25.4)	6
(30A) w/ CPT	2	-	10 (254)	-	10 (254)	4.63 (117.6)	8 (203.2)	8 (203.2)	1 (25.4)	10
(30A) w/ heavy duty pilot devices	4	-	17.4 (442)	14.75 (374.7)	13 (330.2)	5.14 (130.6)	16.4 (416.6)	8 (203.2)	3.25 (82.6)	18
(60A) w/o CPT, 2-to 3-pole	2	-	13.25 (336.6)	-	7.38 (187.5)	6.13 (155.7)	11 (279.4)	5 (127)	1.19 (30.2)	13
(60A) w/ CPT	2	-	13.25 (336.6)	-	12 (304.8)	6.13 (155.7)	11 (279.4)	9 (228.6)	1.5 (38.1)	18
(60A) w/ heavy duty pilot devices	4	-	19.4 (492.8)	16.68 (423.7)	15 (381)	6.62 (168.1)	18.4 (467.4)	10 (254)	3.25 (82.6)	27
(100A) w/o CPT, 2-to 3-pole	2	-	20.25 (514.4)	-	8.75 (222.3)	7.31 (185.7)	17 (431.8)	5.75 (146.1)	1.5 (38.1)	35
(100A) all other	2	-	24.2 (614.7)	21.62 (549.1)	18 (457.2)	8.4 (213.4)	23.2 (589.3)	13 (330.2)	3.25 (82.6)	50
(200A) w/o CPT, 2-to 3-pole	4	-	45.5 (1155.7)	42.75 (1085.9)	17 (431.8)	10.75 (273.1)	44.5 (1130.3)	12 (304.8)	2.5 (63.5)	38
(200A) all other	4	-	45.5 (1155.7)	42.75 (1085.9)	23 (584.2)	10.75 (273.1)	44.5 (1130.3)	18 (457.2)	2.5 (63.5)	55
(300A) w/o CPT, 2-to 3-pole	4	-	45.5 (1155.7)	42.75 (1085.9)	17 (431.8)	10.75 (273.1)	44.5 (1130.3)	12 (304.8)	2.5 (63.5)	130
(300A) all other	4	-	45.5 (1155.7)	42.75 (1085.9)	23 (584.2)	10.75 (273.1)	44.5 (1130.3)	18 (457.2)	2.5 (63.5)	140

Enclosed CR360L NEMA Type 12

Device	Fig. no.	Hub size	Dimension in.(mm)							Approx. shipping wt. (lbs)
			A	A'	B	C	D	E	F	
(30A) w/o CPT	3	-	15.62 (396.7)	14.25 (362)	6.28 (159.5)	5.5 (139.7)	15 (381)	3 (76.2)	2.26 (57.4)	16
(30A) all other	3	-	15.62 (396.7)	14.25 (362)	14.25 (362)	5.5 (139.7)	15 (381)	11 (279.4)	2.26 (57.4)	20
(60A) w/o CPT, 2-to 3-pole	3	-	17.62 (447.5)	16.25 (412.8)	7.63 (193.8)	6.25 (158.8)	17 (431.8)	4.38 (111.3)	2.26 (57.4)	29
(60A) all other	3	-	17.62 (447.5)	16.25 (412.8)	12.25 (311.2)	6.25 (158.8)	17 (431.8)	9 (228.6)	2.26 (57.4)	38
(100A) w/o CPT, 2-to 3-pole	4	-	30 (762)	27.25 (692.2)	10.5 (266.7)	7.25 (184.2)	29 (736.6)	5.75 (146.1)	3.25 (82.6)	40
(100A) all other	4	-	24 (609.6)	21.38 (543.1)	18 (457.2)	7.88 (200.2)	23 (584.2)	13 (330.2)	3.25 (82.6)	55
(200A) w/o CPT, 2-to 3-pole	4	-	45.5 (1155.7)	42.75 (1085.9)	17 (431.8)	10.25 (260.4)	44.5 (1130.3)	12 (304.8)	3.25 (82.6)	44
(200A) all other	4	-	45.5 (1155.7)	42.75 (1085.9)	23 (584.2)	10.25 (260.4)	44.5 (1130.3)	18 (457.2)	3.25 (82.6)	60
(300A) w/o CPT, 2-to 3-pole	4	-	45.5 (1155.7)	42.75 (1085.9)	17 (431.8)	10.25 (260.4)	44.5 (1130.3)	12 (304.8)	3.25 (82.6)	140
(300A) all other	4	-	45.5 (1155.7)	42.75 (1085.9)	23 (584.2)	10.25 (260.4)	44.5 (1130.3)	18 (457.2)	3.25 (82.6)	150

CR360L

Electrically held contactors

Outlines, dimensions in.(mm) and weights (for estimating only)

Enclosed CR360L NEMA Type 3R

Device	Fig. no.	Hub size	Dimension in.(mm)							Approx. shipping wt. (lbs)
			A	A'	B	C	D	E	F	
(30A) w/o CPT	3	1"	15.62 (396.7)	14.5 (368.3)	6.88 (174.8)	5.5 (139.7)	15 (381)	3 (76.2)	2.31 (58.7)	16
(30A) all other	3	1"	15.62 (396.7)	14.5 (368.3)	10.38 (263.7)	5.5 (139.7)	15 (381)	7 (177.8)	2.31 (58.7)	20
(60A) w/o CPT	3	1.5"	17.62 (447.5)	16.5 (419.1)	7.84 (199.1)	6.5 (165.1)	17 (431.8)	4.38 (111.3)	2.32 (58.9)	29
(60A) all other	3	1.5"	17.62 (447.5)	16.5 (419.1)	12.5 (317.5)	6.5 (165.1)	17 (431.8)	8 (203.2)	2.88 (73.2)	38
(100A) all	4	2"	24.5 (622.3)	22 (558.8)	17.2 (436.9)	7.25 (184.2)	23.5 (596.9)	11 (279.4)	3.62 (91.9)	55
(200A) all	4	3"	44.5 (1130.3)	41.5 (1054.1)	22 (558.8)	10.25 (260.4)	43.5 (1104.9)	16 (406.4)	3.62 (91.9)	60
(300A) all	4	3"	44.5 (1130.3)	42 (1066.8)	22 (558.8)	10.25 (260.4)	43.5 (1104.9)	16 (406.4)	3.62 (91.9)	150

Enclosed CR360L NEMA Type 4/4X

Device	Fig. no.	Hub size	Dimension in.(mm)							Approx. shipping wt. (lbs)
			A	A'	B	C	D	E	F	
(30A) w/o CPT	3	1"	15.62 (396.7)	14.5 (368.3)	6.38 (162.1)	5.5 (139.7)	15 (381)	3 (76.2)	1.69 (42.9)	16
(30A) all other	3	1"	15.52 (394.2)	14.5 (368.3)	10.38 (263.7)	5.5 (139.7)	15 (381)	7 (177.8)	1.69 (42.9)	20
(60A) w/o CPT	3	1.5"	17.62 (447.5)	16.5 (419.1)	7.75 (196.9)	6.5 (165.1)	17 (431.8)	4.38 (111.3)	1.69 (42.9)	29
(60A) all other	3	1.5"	17.62 (447.5)	16.5 (419.1)	12.5 (317.5)	6.25 (158.8)	17 (431.8)	8 (203.2)	2.25 (57.2)	38
(100A) all	4	2"	24.5 (622.3)	22 (558.8)	17 (431.8)	7.25 (184.2)	23.5 (596.9)	11 (279.4)	3 (76.2)	55
(200A) all	4	3.5"	44.5 (1130.3)	41.5 (1054.1)	22 (558.8)	10.25 (260.4)	43.5 (1104.9)	16 (406.4)	3 (76.2)	60
(300A) all	4	3.5"	44.5 (1130.3)	41.5 (1054.1)	22 (558.8)	10.25 (260.4)	43.5 (1104.9)	16 (406.4)	3 (76.2)	150

CR160MC

Mechanically held contactors

CR160MC shallow mount 30A - 225A (2 & 3 pole)



CR160MC lighting contactor
for bus mounting

Application information

The CR160MC mechanically held lighting contactors are designed for control of lighting loads such as tungsten, fluorescent, mercury, and sodium, as well as for general noninductive loads. The shallow-type design makes these contactors particularly adaptable for wall-cavity mounting applications.

The silver cadmium oxide main contacts and silver tungsten arcing contacts give the devices capability of handling a wide variety of lighting loads. Built-in clearing interlocks allow control from either momentary or maintained pilot devices.

Features

- Can be mounted in enclosures that fit six-inch thick walls.
- Device is listed by Underwriters Laboratories, Inc.
- Front connected - for convenient wiring.
- Manually operated - by screwdriver or similar tool which reduces chances of tampering.
- Direct bus-mounted forms - for space savings, reduced mounting and wiring costs.
- Withstand current rating - 22,000 amperes rms symmetrical at 480 volts ac maximum and when used with molded case circuit breaker.

CR160MC

Modified assembled forms - mechanically held
 Product number selection instructions
 Order by complete product number

CR160MC Mechanically held contactors

Follow the diagram below and tables on pages 3-36 through 3-38 to select the options and corresponding product number digits for your modified contactor.

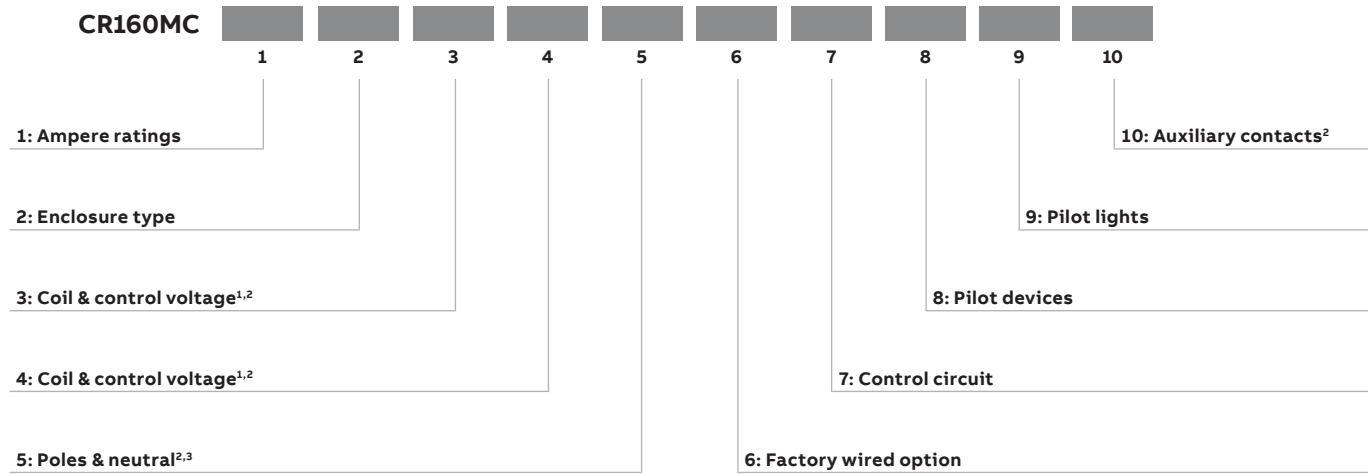

¹Separate control voltages may be ordered.

²When no auxiliary contacts are needed with an Open Bus Mounting and Open Sub-Panel device, the 12 digit product number must be ordered. If auxiliary contacts are required, digits 13 through 16 must be "ACAA" and digit 17 should reflect the needed contacts.

³Replace digits 2 or A for 2 or 3 poles with correct digit if a neutral terminal board is required. Neutral terminal board is not available with flush mount or sub panel with baseplate controllers.

CR160MC

Mechanically held contactors

CR160MC shallow mount 30A - 225A (2 & 3 pole)

1, 2 & 5a: Select ampere rating, enclosure type and number of poles

Continuous amp rating	Enclosure type	No. of poles	1, 2 & 5a: Product number ^{1,2}
30A	Enclosed NEMA Type 1	2	CR160MC32**2
30A	Enclosed NEMA Type 1	3	CR160MC32**A
30A	Enclosed NEMA Type 1 flush mount	2	CR160MC3G**2
30A	Enclosed NEMA Type 1 flush mount	3	CR160MC3G**A
30A	Enclosed NEMA Type 12/3R	2	CR160MC3E**2
30A	Enclosed NEMA Type 12/3R	3	CR160MC3E**A
30A	Enclosed NEMA Type 4/4X	2	CR160MC3F**2
30A	Enclosed NEMA Type 4/4X	3	CR160MC3F**A
30A	Open bus mounting	2	CR160MC35**2
30A	Open bus mounting	3	CR160MC35**A
30A	Open sub panel	2	CR160MC31**2
30A	Open sub panel	3	CR160MC31**A
30A	Sub panel w/ baseplate	2	CR160MC3H**2
30A	Sub panel w/ baseplate	3	CR160MC3H**A
60A	Enclosed NEMA Type 1	2	CR160MC42**2
60A	Enclosed NEMA Type 1	3	CR160MC42**A
60A	Enclosed NEMA Type 1 flush mount	2	CR160MC4G**2
60A	Enclosed NEMA Type 1 flush mount	3	CR160MC4G**A
60A	Enclosed NEMA Type 12/3R	2	CR160MC4E**2
60A	Enclosed NEMA Type 12/3R	3	CR160MC4E**A
60A	Enclosed NEMA Type 4/4X	2	CR160MC4F**2
60A	Enclosed NEMA Type 4/4X	3	CR160MC4F**A
60A	Open bus mounting	2	CR160MC45**2
60A	Open bus mounting	3	CR160MC45**A
60A	Open sub panel	2	CR160MC41**2
60A	Open sub panel	3	CR160MC41**A
60A	Sub panel w/ baseplate	2	CR160MC4H**2
60A	Sub panel w/ baseplate	3	CR160MC4H**A
75A	Enclosed NEMA Type 1	2	CR160MC82**2
75A	Enclosed NEMA Type 1	3	CR160MC82**A
75A	Enclosed NEMA Type 1 flush mount	2	CR160MC8G**2
75A	Enclosed NEMA Type 1 flush mount	3	CR160MC8G**A
75A	Enclosed NEMA Type 12/3R	2	CR160MC8E**2
75A	Enclosed NEMA Type 12/3R	3	CR160MC8E**A
75A	Enclosed NEMA Type 4/4X	2	CR160MC8F**2
75A	Enclosed NEMA Type 4/4X	3	CR160MC8F**A
75A	Open bus mounting	2	CR160MC85**2
75A	Open bus mounting	3	CR160MC85**A
75A	Open sub panel	2	CR160MC81**2
75A	Open sub panel	3	CR160MC81**A
75A	Sub panel w/ baseplate	2	CR160MC8H**2
75A	Sub panel w/ baseplate	3	CR160MC8H**A
100A	Enclosed NEMA Type 1	2	CR160MC52**2
100A	Enclosed NEMA Type 1	3	CR160MC52**A
100A	Enclosed NEMA Type 1 flush mount	2	CR160MC5G**2
100A	Enclosed NEMA Type 1 flush mount	3	CR160MC5G**A
100A	Enclosed NEMA Type 12/3R	2	CR160MC5E**2
100A	Enclosed NEMA Type 12/3R	3	CR160MC5E**A
100A	Enclosed NEMA Type 4/4X	2	CR160MC5F**2
100A	Enclosed NEMA Type 4/4X	3	CR160MC5F**A
100A	Open bus mounting	2	CR160MC55**2
100A	Open bus mounting	3	CR160MC55**A
100A	Open sub panel	2	CR160MC51**2
100A	Open sub panel	3	CR160MC51**A
100A	Sub panel w/ baseplate	2	CR160MC5H**2
100A	Sub panel w/ baseplate	3	CR160MC5H**A
150A	Enclosed NEMA Type 1	2	CR160MC62**2
150A	Enclosed NEMA Type 1	3	CR160MC62**A
150A	Enclosed NEMA Type 1 flush mount	2	CR160MC6G**2

Continuous amp rating	Enclosure type	No. of poles	1, 2 & 5a: Product number ^{1,2}
150A	Enclosed NEMA Type 1 flush mount	3	CR160MC6G**A
150A	Enclosed NEMA Type 12/3R	2	CR160MC6E**2
150A	Enclosed NEMA Type 12/3R	3	CR160MC6E**A
150A	Enclosed NEMA Type 4/4X	2	CR160MC6F**2
150A	Enclosed NEMA Type 4/4X	3	CR160MC6F**A
150A	Open bus mounting	2	CR160MC65**2
150A	Open bus mounting	3	CR160MC65**A
150A	Open sub panel	2	CR160MC61**2
150A	Open sub panel	3	CR160MC61**A
150A	Sub panel w/ baseplate	2	CR160MC6H**2
150A	Sub panel w/ baseplate	3	CR160MC6H**A
200A	Enclosed NEMA Type 1	2	CR160MC72**2
200A	Enclosed NEMA Type 1	3	CR160MC72**A
200A	Enclosed NEMA Type 1 flush mount	2	CR160MC7G**2
200A	Enclosed NEMA Type 1 flush mount	3	CR160MC7G**A
200A	Enclosed NEMA Type 12/3R	2	CR160MC7E**2
200A	Enclosed NEMA Type 12/3R	3	CR160MC7E**A
200A	Enclosed NEMA Type 4/4X	2	CR160MC7F**2
200A	Enclosed NEMA Type 4/4X	3	CR160MC7F**A
200A	Open bus mounting	2	CR160MC75**2
200A	Open bus mounting	3	CR160MC75**A
200A	Open sub panel	2	CR160MC71**2
200A	Open sub panel	3	CR160MC71**A
200A	Sub panel w/ baseplate	2	CR160MC7H**2
200A	Sub panel w/ baseplate	3	CR160MC7H**A
225A	Enclosed NEMA Type 1	2	CR160MC92**2
225A	Enclosed NEMA Type 1	3	CR160MC92**A
225A	Enclosed NEMA Type 1 flush mount	2	CR160MC9G**2
225A	Enclosed NEMA Type 1 flush mount	3	CR160MC9G**A
225A	Enclosed NEMA Type 12/3R	2	CR160MC9E**2
225A	Enclosed NEMA Type 12/3R	3	CR160MC9E**A
225A	Enclosed NEMA Type 4/4X	2	CR160MC9F**2
225A	Enclosed NEMA Type 4/4X	3	CR160MC9F**A
225A	Open bus mounting	2	CR160MC95**2
225A	Open bus mounting	3	CR160MC95**A
225A	Open sub panel	2	CR160MC91**2
225A	Open sub panel	3	CR160MC91**A
225A	Sub panel w/ baseplate	2	CR160MC9H**2
225A	Sub panel w/ baseplate	3	CR160MC9H**A

¹Replace ** with coil and control voltages selection.

²Replace digits 2 or A for 2 or 3 poles with correct digit if a neutral terminal board is required. Neutral terminal board is not available with flush mount or sub panel with baseplate controllers.

5b: Neutral terminal option

Use in place of the last 2 or A for 2 or 3 poles if a neutral terminal board is required. Only available on enclosed products except flush mount or sub panel with baseplate controllers.

Description	5b: Product no. digit
30 to 100 amps, 2-pole	7
30 to 100 amps, 3-pole	8
150 to 225 amps, 2-pole	7
150 to 225 amps, 3-pole	8

CR160MC

Mechanically held contactors

CR160MC shallow mount 30A - 225A (2 & 3 pole)

3 & 4: Select contactor, coil, control module and relay voltages^{1,2}

Contactor and coil voltage ^{3,4}	Control module and relay voltage ^{2,3,5}	3 & 4: Product no. digits	Enclosure type	Factory wiring	CPT and fusing
115-120V 60Hz	115-120V 60Hz	02	Open or enclosed	No	No CPT or fusing
200-208V 60Hz	200-208V 60Hz	23	Open or enclosed	No	No CPT or fusing
230-240V 60Hz	230-240V 60Hz	03	Open or enclosed	No	No CPT or fusing
265-277V 60Hz	265-277V 60Hz	82	Open or enclosed	No	No CPT or fusing
460-480V 60Hz	460-480V 60Hz	04	Open or enclosed	No	No CPT or fusing
115-120V 60Hz	24V 60Hz	30	Enclosed only	Yes	No CPT, 2 fuses for coil circuit & user supplied control voltage
200-208V 60Hz	24V 60Hz	32	Enclosed only	Yes	No CPT, 2 fuses for coil circuit & user supplied control voltage
230-240V 60Hz	24V 60Hz	34	Enclosed only	Yes	No CPT, 2 fuses for coil circuit & user supplied control voltage
265-277V 60Hz	24V 60Hz	36	Enclosed only	Yes	No CPT, 2 fuses for coil circuit & user supplied control voltage
460-480V 60Hz	24V 60Hz	38	Enclosed only	Yes	No CPT, 2 fuses for coil circuit & user supplied control voltage
115-120V 60Hz	24V DC	40	Enclosed only	Yes	No CPT, 2 fuses for coil circuit & user supplied control voltage
200-208V 60Hz	24V DC	42	Enclosed only	Yes	No CPT, 2 fuses for coil circuit & user supplied control voltage
230-240V 60Hz	24V DC	44	Enclosed only	Yes	No CPT, 2 fuses for coil circuit & user supplied control voltage
265-277V 60Hz	24V DC	46	Enclosed only	Yes	No CPT, 2 fuses for coil circuit & user supplied control voltage
460-480V 60Hz	24V DC	48	Enclosed only	Yes	No CPT, 2 fuses for coil circuit & user supplied control voltage
200-208V 60Hz	120V 60Hz	52	Enclosed only	Yes	No CPT, 2 fuses for coil circuit & user supplied control voltage
230-240V 60Hz	120V 60Hz	54	Enclosed only	Yes	No CPT, 2 fuses for coil circuit & user supplied control voltage
265-277V 60Hz	120V 60Hz	56	Enclosed only	Yes	No CPT, 2 fuses for coil circuit & user supplied control voltage
460-480V 60Hz	120V 60Hz	58	Enclosed only	Yes	No CPT, 2 fuses for coil circuit & user supplied control voltage
115-120V 60Hz	24V 60Hz	60	Enclosed only	Yes	CPT with 2 primary & 1 secondary fuse & 2 coil circuit fuses
200-208V 60Hz	24V 60Hz	62	Enclosed only	Yes	CPT with 2 primary & 1 secondary fuse & 2 coil circuit fuses
230-240V 60Hz	24V 60Hz	64	Enclosed only	Yes	CPT with 2 primary & 1 secondary fuse & 2 coil circuit fuses
265-277V 60Hz	24V 60Hz	66	Enclosed only	Yes	CPT with 2 primary & 1 secondary fuse & 2 coil circuit fuses
460-480V 60Hz	24V 60Hz	68	Enclosed only	Yes	CPT with 2 primary & 1 secondary fuse & 2 coil circuit fuses
200-208V 60Hz	120V 60Hz	92	Enclosed only	Yes	CPT with 2 primary & 1 secondary fuse & 2 coil circuit fuses
230-240V 60Hz	120V 60Hz	94	Enclosed only	Yes	CPT with 2 primary & 1 secondary fuse & 2 coil circuit fuses
265-277V 60Hz	120V 60Hz	96	Enclosed only	Yes	CPT with 2 primary & 1 secondary fuse & 2 coil circuit fuses
460-480V 60Hz	120V 60Hz	98	Enclosed only	Yes	CPT with 2 primary & 1 secondary fuse & 2 coil circuit fuses

¹For open bus mounting and open sub-panel devices, no other selections are needed unless auxiliary contacts are required. If auxiliary contacts are not needed, the 12 digit product number must be ordered.

²For products where factory wiring is provided, an interposing relay is supplied. The relay energizes contactor and has a coil voltage equal to the selected control voltage. See wiring diagrams for details.

³Contacts used to operate the device's coil and control module must have a B600 rating as a minimum.

⁴For applications where the coil is energized independently the source must be able to switch 3000VA.

⁵For applications where the control module will be independently energized, the source must be able to switch 26VA inrush and 4VA holding (AC circuits) or 3VA inrush and holding (DC circuits).

6: Select factory wiring

Factory control wiring	6: Product no. digit	Enclosure type
No	A	Open or enclosed
Yes	B	Enclosed

Note: Factory wiring must be "B" when coil and control voltages are different, or if pilot devices or pilot lights are required.

7: Select control circuit type⁶

Control circuit	7: Product no. digit	Enclosure type
2 wire control	B	Enclosed only
3 wire control	C	Open or enclosed

⁶Devices with factory wiring "A" are only available with 3 wire control circuits.

8: Select enclosure mounted pilot devices⁷ (Available only when there is an enclosure.)

Heavy duty, 30mm operators	8: Product no. digit
None	A
On-off push buttons ⁸	B
Off-on selector switch ^{8,9}	C
On-off-auto selector switch ⁹	D
Hand-off-auto selector switch ⁹	E
Off-auto selector switch ^{8,9}	F
Off-on selector switch with spring return to center ⁸	G
On-off-auto keyed selector switch ^{9,10}	H
Hand-off-auto keyed selector switch ^{9,10}	J

⁷Not available in flush mount or sub panel with baseplate controllers.

⁸Momentary operation of pilot device to control contactor. Available with 3 wire control.

⁹Maintained operation of pilot device to control contactor. Available with 2 wire control.

¹⁰Key removable in all positions.

CR160MC

Mechanically held contactors

CR160MC shallow mount 30A - 225A (2 & 3 pole)

9: Select enclosure mounted pilot lights^{11,12}

(Available only when there is an enclosure.)

Heavy duty, 30mm pilot lights with interchangeable red and green lenses	Type	9: Product no. digit
None	-	A
Red/green light ("on")	Standard	B
Red/green light ("off")	Standard	C
Red/green ("on") & red/green ("off") lights	Standard	F
Red/green light ("on")	Push-to-test	D
Red/green light ("off")	Push-to-test	E
Red/green ("on") & red/green ("off") lights	Push-to-test	G

¹¹Not available in flush mount or sub panel with baseplate controllers.

¹²"On" pilot lights use the NO auxiliary contact; for off lights use the NC auxiliary contact.

10: Select auxiliary contacts

Description	10: Product no. digit
None	A
1NO extra	B
1NC extra	C
1NO and 1NC extra	D

Note: "On" pilot lights use a NO auxiliary contact. "Off" pilot lights use a NC auxiliary contact.

CR160MC

Mechanically held contactors

CR160MC shallow mount 30A - 225A (2 & 3 pole)

Technical data

Maximum AC voltage ratings

Maximum AC volts			
Type of load	Line	Load	Load
Tungsten	480	277	480
Ballast	600	277	600
General use	600	277	600

Control line wiring

Control lines extending several hundred feet from the voltage source and pilot device(s) to the lighting contactor may require special consideration. Select a wire size adequate to provide not less than 85% of rated coil voltage at the coil, for pickup, while passing inrush current through the control circuit. Suggested wire sizes, for use with a “stiff” source of control voltage, are listed below. Interposing control relays are available for greater distances, and for use with pilot devices having ratings lower than those required for direct operation of the contactor coils.

Contactor size	Wire size	Approx. resistance of single conductor copper wire ohms/1000 ft	Max. control line distance ¹	
			115V-60Hz	230V-60Hz
30-225A	10	1	500 ft	1500 ft
30-225A	12	1.6	315 ft	950 ft
30-225A	14	2.5	200 ft	600 ft

¹The use of two contactors on one remote control station would reduce the maximum control line distance to 1/2 the specified table value, etc.

Coil inrush current and recommended control circuit fuse size

Voltage 60Hz	Inrush (amperes)	NEC fuse size (amperes)
	CR160MC	CR160MC
115	26	8
230	13	4
277 ²	10	3
460 ²	7	2

²Breaking all lines

Note: Use of energy management systems, multiple control stations, or signals require prime control logic or use of a 2-wire control relay/module, to assure that on and off signals are never applied simultaneously to a mechanically held contactor.

Control transformer data

When the lighting contactor is used on the secondary of a transformer, the transformer must be sized to provide the required inrush current with 90% voltage applied to the transformer primary. As an alternative, utilize an interposing relay with a lower VA CPT. Connect the circuit with the line voltage driving the coil and the control voltage driving the relay coil.

Reference publications

Instructions	GEH-3202
--------------	----------

CR160MC

Mechanically held contactors

Outlines, dimensions and weights (for estimating only)

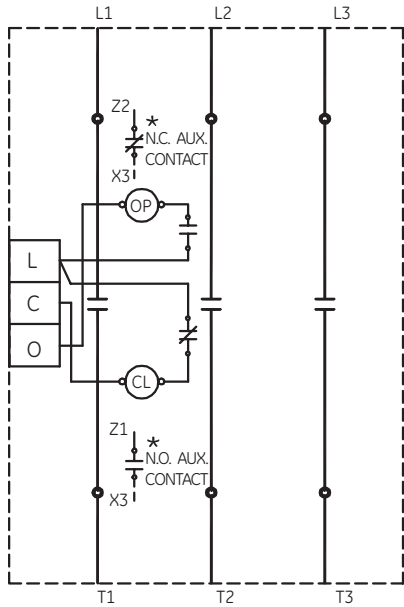

Open wiring example

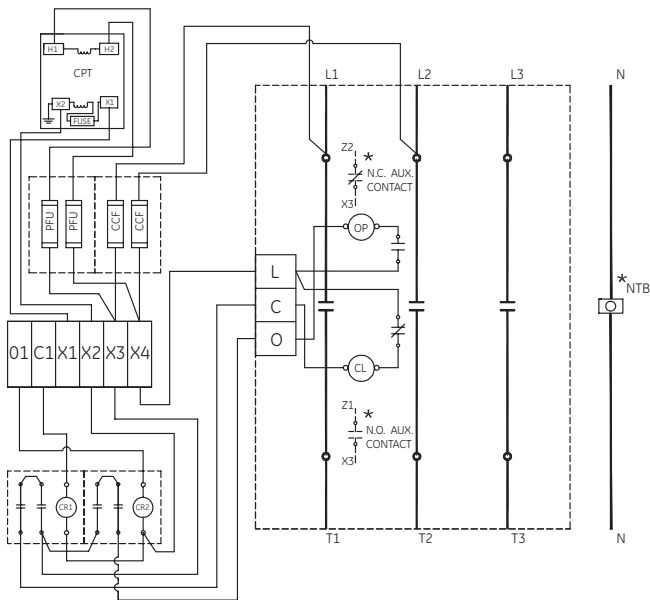

Enclosed wiring example

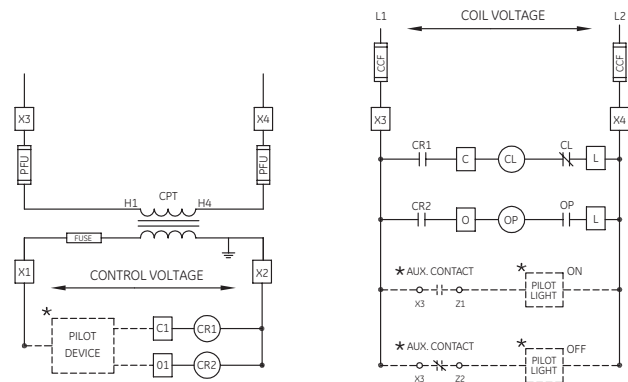

CR160MC

Mechanically held contactors

Outlines, dimensions and weights (for estimating only)

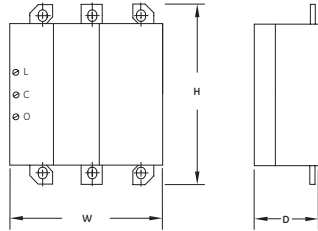

Open bus mounting contactor
30, 60, 75 and 100 amp

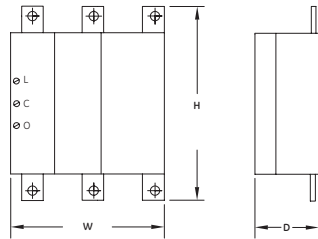

Open bus mounting contactor
150, 200 and 225 amp

Open bus mounting contactor

Amp rating	Weight (lbs)	Weight (kgs)	H x W x D (in)	H x W x D (mm)	Drawing no.
30, 60, 75 & 100	9.0	4.1	8.31 x 7.13 x 3.13	211.0 x 181.1 x 79.5	55-172305
150, 200 & 225	10.0	4.5	9.50 x 7.13 x 3.13	241.3 x 181.1 x 79.5	55-172305

Type 1 enclosures

Amp rating	Weight (lbs)	Weight (kgs)	H x W x D (in)	H x W x D (mm)	Drawing no.
30, 60, 75 & 100	62.0	28.10	25.0 x 15.9 x 6.5	635.0 x 404.4 x 165.9	55-217830
150, 200 & 225	92.0	41.70	42.6 x 18.3 x 6.6	1081.0 x 463.3 x 167.9	55-217831

Open sub panel contactor

Amp rating	Weight (lbs)	Weight (kgs)	H x W x D (in)	H x W x D (mm)	Drawing no.
30	13.0	5.9	10.5 x 7.5 x 3.8	266.7 x 190.5 x 95.3	55-172306
60, 75 & 100	14.0	6.4	11.4 x 7.8 x 3.8	289.1 x 196.8 x 95.3	55-172306
150	16.5	7.5	13.3 x 9.0 x 3.8	336.6 x 228.3 x 95.3	55-172306
220 & 225	16.5	7.5	14.0 x 9.0 x 3.8	355.6 x 228.6 x 95.3	55-172306

Open sub panel contactor with baseplate

Amp rating	Weight (lbs)	Weight (kgs)	H x W x D (in)	H x W x D (mm)	Drawing no.
30, 60, 75, 100, 150, 200 & 225	32.0	14.5	20.5 x 13.0 x 4.6	519.2 x 330.2 x 116.0	55-217838

Type 1 flush mount enclosures

Amp rating	Weight (lbs)	Weight (kgs)	H x W x D (in)	H x W x D (mm)	Drawing no.
30, 60, 75 & 100	62.0	28.10	21.6 x 14.5 x 5.0	549.1 x 368.3 x 127.0	55-217836
150, 200 & 225	92.0	41.70	39.2 x 14.5 x 5.0	999.5 x 368.3 x 127.0	55-217837

Type 12/3R enclosures

Amp rating	Weight (lbs)	Weight (kgs)	H x W x D (in)	H x W x D (mm)	Drawing no.
30, 60, 75 & 100	62.0	28.10	28.2 x 17.8 x 7.7	715.8 x 452.1 x 194.2	55-217832
150, 200 & 225	92.0	41.70	45.7 x 21.2 x 7.7	1161.8 x 537.7 x 194.2	55-217833

Type 4/4X enclosures

Amp rating	Weight (lbs)	Weight (kgs)	H x W x D (in)	H x W x D (mm)	Drawing no.
30, 60, 75 & 100	62.0	28.10	25.0 x 15.9 x 6.5	635.0 x 404.4 x 165.9	55-217834
150, 200 & 225	92.0	41.70	42.6 x 18.3 x 6.5	1081.0 x 463.3 x 165.9	55-217835

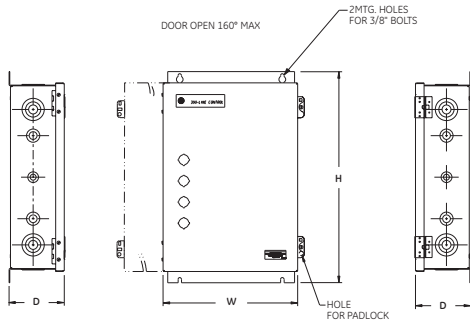

Type 1 enclosure

Wiring diagrams

Control circuit	Enclosure type	Drawing no.
3 wire	Open	55-686607
2 wire, no CPT, control & coil voltage same	Enclosed	55-686608
3 wire, no CPT, control & coil voltage same	Enclosed	55-686609
2 wire, no CPT, control & coil voltage different	Enclosed	55-686610
3 wire, no CPT, control & coil voltage different	Enclosed	55-686611
2 wire, CPT	Enclosed	55-686612
3 wire, CPT	Enclosed	55-686613