

hammond
POWER SOLUTIONS



LEGACY CONTROL MOLDED STYLE



hammondpowersolutions.com

energizing our world

Distributed by Gross Automation | +1 (262) 252-1600 | sales@grossautomation.com

Legacy Control Molded Style

Innovative Design

The HPS legacy control molded style transformer is a unique innovative and compact design that provides the ideal solution for any industrial control application.

The HPS Imperator's unique terminal block design allows for the quick and easy installation of standard secondary or optional primary 13/32" x 1 1/2" midget/type CC fuse clips on every unit. This is the simplest and most inexpensive fusing installation provided on any industrial control transformer in the market today.

The windings and internal terminations of the HPS Imperator are encapsulated which protects them from moisture, dirt and other airborne contaminants. The custom molded coil covers, with their unique 'fin shaped' design, combine superior transformer cooling properties with a clean bold look.

The HPS Imperator utilizes custom serrated terminals, in combination with standard SEMS washer screws, making connections quicker to install; and provides superior connection strength when connecting with bare, solid or stranded wire. It also allows for ring or spade termination connectors.

The Perfect Solution

The HPS legacy control molded style transformer are specifically designed to meet the high inrush current levels where electromagnetic components such as relays, solenoids and magnetic motor starters are used.

With 11 standard voltage groups, a VA range from 50VA to 1500VA and available with standard secondary and optional primary fuse kits, the HPS legacy control molded style transformer provides the perfect solution for any application.

Superior Quality & Value

The HPS legacy control molded style transformer design, utilizing superior insulation systems and being constructed with high quality silicon steel laminations for optimum performance, meet or exceed UL, CSA and CE standards.

Backed by an industry leading LIFETIME warranty, the HPS Imperator industrial control transformer line offers superior performance, quality and value.

Applications



Process Controls



Panel Shops



Machine Automation



Control Boards



HVAC Panels



Power Timers, Solenoids, and Controllers

Industries



Paper Mills



Printing



Automotive



Packaging Systems



Process Automation

Approvals

- UL Listed (Approved for U.S. and Canada)
- CE Mark standard on all units
- RoHS Compliant





Features and Benefits

- 600V class, rated industrial control transformers
- 11 standard multi primary and secondary voltage groups available¹
- 50/60 Hertz (60Hz on PH***AJ & PH***AR)
- VA range from 50 up to 1500¹
- Robust insulation system:
 - › 50-150VA, temperature rise 55°C, insulation class 130°C
 - › 250-1500VA, temperature rise 80°C, insulation class 130°C
- Constructed with high quality silicon steel laminations that provide optimum performance and reliability
- Encapsulated coils encased in a custom injection molded cover, protect coils and terminations from moisture, dirt and other industrial airborne contaminants
- Mounting Feet: made of heavy steel and welded or bolted to the core, these mounting feet provide superior strength in a compact design
- Termination: combination slot/Phillips #6 screw, complete with SEMS washer (suitable for 18 AWG to 14 AWG solid or 14 AWG stranded wire)
- Standard SEMS washers - supplied on all units²
- Standard secondary fuse kits -utilizing 13/32" x 1 1/2" [10.3 x 38.1 mm] midget/type CC fuse clips (supplied with all units)
- Optional primary fuse kits available utilizing 13/32" x 1 1/2" [10.3 x 38.1 mm] midget/type CC fuse clips
- Optional finger safe terminal covers available on all units
- LIFETIME Warranty (Limited)

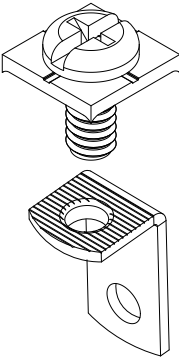

¹ Special voltages and VA sizes available upon request
² Excluding PH750PG, PH1000PG, PH750MLI, PH1000MLI

Terminal connection numbers molded into terminal block and correspond to nameplate and wiring diagrams, make connecting the HPS Imperator quick and simple.

Innovative terminal block design provides for easy hook-up and installation of fuse clips.

Optional removable finger safe terminal covers available on all standard units.

SEMS washer allows for easy connection of supply or load wires with or without terminal connectors

Standard secondary and optional primary fuse kits utilizing 13/32" x 1 1/2" [10.3 x 38.1 mm] midget/type CC fuse clips provide an economical solution to your fusing requirements (fuses not supplied).

Made of heavy steel and welded or bolted to the core, these mounting feet provide superior strength in a compact design.

Custom injection molded coil cover with its unique "fin shaped" design combine superior cooling properties with a clean, bold look.

SELECTION TABLES

HPS LEGACY CONTROL MOLDED STYLE

GROUP A

PRIMARY VOLTAGE:				600	575	550	60 HZ						
SECONDARY VOLTAGE:				120 X 240	115 X 230	110 X 220							
VA Rating	Catalog Number	Mtg. Fig.	Output Amps	Overall Dimensions*			Mounting Centers*		Mounting Slot*	Height with Finger Guard*	Depth with Finger Guard*	Approx. Ship Weight Lbs.*	Opt. Pri. Fuse Kit P/N
				A	B	C	D	E	G X H				
50	PH50AJ	A	0.42/0.21	3.00 [72.20]	3.81 [96.78]	3.19 [81.03]	2.50 [63.50]	2.25 [57.15]	0.22 x 0.44 [5.59 x 11.18]	4.00 [101.60]	5.25 [133.35]	2.7 [1.3]	PFK1
75	PH75AJ	A	0.63/0.31	3.25 [82.55]	3.69 [93.73]	3.56 [90.43]	2.63 [66.81]	2.50 [63.50]	0.22 x 0.44 [5.59 x 11.18]	4.37 [111.00]	5.13 [130.31]	2.8 [1.3]	PFK1
100	PH100AJ	A	0.83/0.42	3.25 [82.55]	4.06 [103.13]	3.63 [92.21]	2.63 [66.81]	2.63 [66.81]	0.22 x 0.44 [5.59 x 11.18]	4.44 [112.78]	5.50 [139.70]	4.1 [1.9]	PFK1
150	PH150AJ	B	1.25/0.63	4.00 [101.60]	4.63 [117.61]	3.81 [96.78]	3.38 [85.86]	2.75 [69.85]	0.22 x 0.75 [5.59 x 19.05]	4.50 [114.30]	6.13 [155.71]	4.9 [2.3]	PFK2
250	PH250AJ	B	2.08/1.04	4.50 [114.30]	5.25 [133.35]	3.81 [96.78]	3.75 [95.25]	3.13 [79.51]	0.22 x 0.75 [5.59 x 19.05]	4.50 [114.30]	6.75 [171.45]	7.0 [3.2]	PFK2
350	PH350AJ	B	2.92/1.46	4.50 [114.30]	4.88 [123.96]	4.44 [112.78]	3.75 [95.25]	3.75 [95.25]	0.22 x 0.75 [5.59 x 19.05]	5.18 [131.58]	6.38 [162.06]	8.3 [3.8]	PFK3
500	PH500AJ	B	4.17/2.08	4.75 [120.65]	5.56 [141.23]	4.31 [109.48]	4.06 [103.13]	3.44 [87.38]	0.31 x 0.94 [7.88 x 23.88]	5.13 [130.31]	7.06 [179.33]	11.6 [5.3]	PFK3
750	PH750AJ	B	6.25/3.13	5.13 [130.31]	6.38 [162.06]	4.31 [109.48]	4.38 [111.26]	4.00 [101.60]	0.31 x 0.81 [7.88 x 20.58]	5.13 [130.31]	7.88 [200.16]	16.6 [7.5]	PFK3
1000	PH1000AJ	B	8.33/4.17	5.25 [133.35]	6.50 [165.10]	4.94 [125.48]	4.50 [114.30]	4.09 [103.89]	0.31 x 0.81 [7.88 x 20.58]	5.56 [141.23]	8.00 [203.20]	21.0 [9.5]	PFK3
1500	PH1500AJ	B	12.5/6.25	5.25 [133.35]	7.56 [192.03]	4.94 [125.48]	4.50 [114.30]	5.44 [138.18]	0.38 x 1.00 [9.66 x 25.4]	5.56 [141.23]	9.06 [230.13]	30.0 [13.5]	PFK3

*Secondary fuse clips, fuse clip mounting screws and primary and secondary voltage links/jumpers supplied standard with transformers.
Please refer to page 11 for dimensional drawings. Special voltages and VA sizes available upon request.

*Dimensions in Inches [mm]
Weight in Lbs. [kg]

GROUP B

PRIMARY VOLTAGE:				600	575	550	60 HZ						
SECONDARY VOLTAGE:				12 X 24	11.5 X 23	11 X 22							
VA Rating	Catalog Number	Mtg. Fig.	Output Amps	Overall Dimensions*			Mounting Centers*		Mounting Slot*	Height with Finger Guard*	Depth with Finger Guard*	Approx. Ship Weight Lbs.*	Opt. Pri. Fuse Kit P/N
				A	B	C	D	E	G X H				
50	PH50AR	A	4.17/2.08	3.00 [76.20]	3.81 [96.78]	3.19 [81.03]	2.50 [63.50]	2.25 [57.15]	0.22 x 0.44 [5.59 x 11.18]	4.00 [101.60]	5.25 [133.35]	2.7 [1.3]	PFK1
75	PH75AR	A	6.25/3.13	3.25 [82.55]	3.69 [93.73]	3.56 [90.43]	2.63 [66.81]	2.50 [63.50]	0.22 x 0.44 [5.59 x 11.18]	4.37 [111.00]	5.13 [130.31]	2.8 [1.3]	PFK1
100	PH100AR	A	8.33/4.17	3.25 [82.55]	4.19 [106.43]	3.63 [92.21]	2.63 [66.81]	2.63 [66.81]	0.22 x 0.44 [5.59 x 11.18]	4.50 [114.30]	5.63 [143.01]	4.5 [2.1]	PFK1
150	PH150AR	B	12.5/6.25	4.00 [101.60]	4.94 [125.48]	3.81 [96.78]	3.38 [85.86]	2.75 [69.85]	0.22 x 0.75 [5.59 x 19.05]	4.50 [114.30]	6.44 [163.58]	5.7 [2.6]	PFK2
250	PH250AR	B	20.8/10.4	4.50 [114.30]	5.44 [138.18]	3.81 [96.78]	3.75 [95.25]	3.13 [79.51]	0.22 x 0.75 [5.59 x 19.05]	4.50 [114.30]	6.94 [176.28]	7.5 [3.4]	PFK2
350	PH350AR	B	29.2/14.6	4.50 [114.30]	4.88 [123.96]	4.44 [112.78]	3.75 [95.25]	3.75 [95.25]	0.22 x 0.75 [5.59 x 19.05]	5.18 [131.58]	6.38 [162.06]	8.3 [3.8]	PFK3
500	PH500AR	B	41.7/20.8	4.75 [120.65]	5.56 [141.23]	4.31 [109.48]	4.06 [103.13]	3.44 [87.38]	0.31 x 0.94 [7.88 x 23.88]	5.13 [130.31]	7.06 [179.33]	11.6 [5.3]	PFK3

*Secondary fuse clips, fuse clip mounting screws and primary and secondary voltage links/jumpers supplied with transformers.
Please refer to page 11 for dimensional drawings. Special voltages and VA sizes available upon request.

*Dimensions in Inches [mm]
Weight in Lbs. [kg]

SELECTION TABLES

HPS LEGACY CONTROL MOLDED STYLE

GROUP C

PRIMARY VOLTAGE:				240 X 480	230 X 460	220 X 440	50/60 HZ						
SECONDARY VOLTAGE:				120 X 240	115 X 230	110 X 220							
VA Rating	Catalog Number	Mtg. Fig.	Output Amps	Overall Dimensions*			Mounting Centers*		Mounting Slot*	Height with Finger Guard*	Depth with Finger Guard*	Approx. Ship Weight Lbs.*	Opt. Pri. Fuse Kit P/N
				A	B	C	D	E	G X H				
50	PH50MQMJ	A	0.42/0.21	3.00 [76.20]	4.38 [111.26]	3.19 [81.03]	2.50 [63.50]	2.25 [57.15]	0.22 x 0.44 [5.59 x 11.18]	4.00 [101.60]	5.82 [147.83]	3.5 [1.6]	PFK1
75	PH75MQMJ	A	0.63/0.31	3.25 [82.55]	3.88 [98.56]	3.56 [90.43]	2.63 [66.81]	2.50 [63.50]	0.22 x 0.44 [5.59 x 11.18]	4.37 [111.00]	5.32 [135.13]	3.5 [1.6]	PFK1
100	PH100MQMJ	A	0.83/0.42	3.25 [82.55]	4.19 [106.43]	3.63 [92.21]	2.63 [66.81]	2.63 [66.81]	0.22 x 0.44 [5.59 x 11.18]	4.50 [114.30]	5.63 [143.01]	4.5 [2.1]	PFK1
150	PH150MQMJ	B	1.25/0.63	4.00 [101.60]	4.94 [125.48]	3.81 [96.78]	3.38 [85.86]	2.75 [69.85]	0.22 x 0.75 [5.59 x 19.05]	4.50 [114.30]	6.44 [163.58]	5.7 [2.6]	PFK2
250	PH250MQMJ	B	2.08/1.04	4.50 [114.30]	5.44 [138.18]	3.81 [96.78]	3.75 [95.25]	3.13 [79.51]	0.22 x 0.75 [5.59 x 19.05]	4.50 [114.30]	6.94 [176.28]	7.5 [3.4]	PFK2
350	PH350MQMJ	B	2.92/1.46	4.50 [114.30]	5.19 [131.83]	4.44 [112.78]	3.75 [95.25]	3.75 [95.25]	0.22 x 0.75 [5.59 x 19.05]	5.18 [131.58]	6.69 [169.93]	10.1 [4.6]	PFK3
500	PH500MQMJ	B	4.17/2.08	4.75 [120.65]	5.94 [150.88]	4.31 [109.48]	4.06 [103.13]	3.81 [96.78]	0.31 x 0.94 [7.88 x 23.88]	5.13 [130.31]	7.44 [188.98]	14.2 [6.4]	PFK3
750	PH750MQMJ	B	6.25/3.13	5.13 [130.31]	6.69 [169.93]	4.31 [109.48]	4.38 [111.26]	4.31 [109.48]	0.31 x 0.81 [7.88 x 20.58]	5.13 [130.31]	8.19 [208.03]	16.6 [7.5]	PFK3
1000	PH1000MQMJ	B	8.33/4.17	5.25 [133.35]	6.81 [172.98]	4.94 [125.48]	4.50 [114.30]	4.44 [112.78]	0.31 x 0.81 [7.88 x 20.58]	5.56 [141.23]	8.31 [211.08]	23.6 [10.7]	PFK3
1500	PH1500MQMJ	B	12.5/6.25	5.25 [133.35]	8.19 [208.03]	4.94 [125.48]	4.50 [114.30]	6.06 [153.93]	0.38 x 1.00 [9.66 x 25.4]	5.56 [141.23]	9.69 [246.13]	32.0 [14.4]	PFK3

*Secondary fuse clips, fuse clip mounting screws and primary and secondary voltage links/jumpers supplied standard with transformers.

*Dimensions in Inches [mm]
Weight in Lbs. [kg]

Please refer to page 11 for dimensional drawings. Special voltages and VA sizes available upon request.

GROUP D

PRIMARY VOLTAGE:				240 X 480	230 X 460	220 X 440	50/60 HZ						
SECONDARY VOLTAGE:				12 X 24	11.5 X 23	11 X 22							
VA Rating	Catalog Number	Mtg. Fig.	Output Amps	Overall Dimensions*			Mounting Centers*		Mounting Slot*	Height with Finger Guard*	Depth with Finger Guard*	Approx. Ship Weight Lbs.*	Opt. Pri. Fuse Kit P/N
				A	B	C	D	E	G X H				
50	PH50QR	A	4.17/2.08	3.00 [76.20]	4.38 [111.26]	3.19 [81.03]	2.50 [63.50]	2.25 [57.15]	0.22 x 0.44 [5.59 x 11.18]	4.00 [101.60]	5.82 [147.83]	3.5 [1.6]	PFK1
75	PH75QR	A	6.25/3.13	3.25 [82.55]	3.88 [98.56]	3.56 [90.43]	2.63 [66.81]	2.50 [63.50]	0.22 x 0.44 [5.59 x 11.18]	4.37 [111.00]	5.32 [135.13]	3.5 [1.6]	PFK1
100	PH100QR	A	8.33/4.17	3.25 [82.55]	4.19 [106.43]	3.63 [92.21]	2.63 [66.81]	2.63 [66.81]	0.22 x 0.44 [5.59 x 11.18]	4.44 [112.78]	5.63 [143.01]	4.5 [2.1]	PFK1
150	PH150QR	B	12.5/6.25	4.00 [101.60]	4.94 [125.48]	3.81 [96.78]	3.38 [85.86]	2.75 [69.85]	0.22 x 0.75 [5.59 x 19.05]	4.50 [114.30]	6.44 [163.58]	5.7 [2.6]	PFK2
250	PH250QR	B	20.8/10.4	4.50 [114.30]	5.44 [138.18]	3.81 [96.78]	3.75 [95.25]	3.13 [79.51]	0.22 x 0.75 [5.59 x 19.05]	4.50 [114.30]	6.94 [176.28]	7.5 [3.4]	PFK2
350	PH350QR	B	29.2/14.6	4.50 [114.30]	5.19 [131.83]	4.44 [112.78]	3.75 [95.25]	3.75 [95.25]	0.22 x 0.75 [5.59 x 19.05]	5.18 [131.58]	6.69 [169.93]	10.1 [4.6]	PFK3
500	PH500QR	B	41.7/20.8	4.75 [120.65]	5.94 [150.88]	4.31 [109.48]	4.06 [103.13]	3.81 [96.78]	0.31 x 0.94 [7.88 x 23.88]	5.13 [130.31]	7.44 [188.98]	14.2 [6.4]	PFK3

*Secondary fuse clips, fuse clip mounting screws and primary and secondary voltage links/jumpers supplied with transformers.
Please refer to page 11 for dimensional drawings. Special voltages and VA sizes available upon request.

*Dimensions in Inches [mm]
Weight in Lbs. [kg]

SELECTION TABLES

HPS LEGACY CONTROL MOLDED STYLE

GROUP E

PRIMARY VOLTAGE: **208 X 416** 200 X 400 190 X 380 50/60 HZ
 SECONDARY VOLTAGE: **120 X 240** 115 X 230 110 X 220

VA Rating	Catalog Number	Mtg. Fig.	Output Amps	Overall Dimensions*			Mounting Centers*		Mounting Slot*	Height with Finger Guard*	Depth with Finger Guard*	Approx. Ship Weight Lbs.*	Opt. Pri. Fuse Kit P/N
				A	B	C	D	E	G X H				
50	PH50SP	A	0.42/0.21	3.00 [76.20]	4.38 [111.26]	3.19 [81.03]	2.50 [63.50]	2.25 [57.15]	0.22 x 0.44 [5.59 x 11.18]	4.00 [101.60]	5.82 [147.83]	3.5 [1.6]	PFK1
75	PH75SP	A	0.63/0.31	3.25 [82.55]	3.88 [98.56]	3.56 [90.43]	2.63 [66.81]	2.50 [63.50]	0.22 x 0.44 [5.59 x 11.18]	4.37 [111.00]	5.32 [135.13]	3.5 [1.6]	PFK1
100	PH100SP	A	0.83/0.42	3.25 [82.55]	4.19 [106.43]	3.63 [92.21]	2.63 [66.81]	2.63 [66.81]	0.22 x 0.44 [5.59 x 11.18]	4.50 [114.30]	5.63 [143.01]	4.5 [2.1]	PFK1
150	PH150SP	B	1.25/0.63	4.00 [101.60]	4.94 [125.48]	3.81 [96.78]	3.38 [85.86]	2.75 [69.85]	0.22 x 0.75 [5.59 x 19.05]	4.50 [114.30]	6.44 [163.58]	5.7 [2.6]	PFK2
250	PH250SP	B	2.08/1.04	4.50 [114.30]	5.44 [138.18]	3.81 [96.78]	3.75 [95.25]	3.13 [79.51]	0.22 x 0.75 [5.59 x 19.05]	4.50 [114.30]	6.94 [176.28]	7.5 [3.4]	PFK2
350	PH350SP	B	2.92/1.46	4.50 [114.30]	5.19 [131.83]	4.44 [112.78]	3.75 [95.25]	3.75 [95.25]	0.22 x 0.75 [5.59 x 19.05]	5.18 [131.58]	6.69 [169.93]	10.1 [4.6]	PFK3
500	PH500SP	B	4.17/2.08	4.75 [120.65]	5.94 [150.88]	4.31 [109.48]	4.06 [103.13]	3.81 [96.78]	0.31 x 0.94 [7.88 x 23.88]	5.13 [130.31]	7.44 [188.98]	14.2 [6.4]	PFK3
750	PH750SP	B	6.25/3.13	5.13 [130.31]	6.69 [169.93]	4.31 [109.48]	4.38 [111.26]	4.31 [109.48]	0.31 x 0.81 [7.88 x 20.58]	5.01 [127.34]	8.19 [208.03]	16.6 [7.5]	PFK3
1000	PH1000SP	B	8.33/4.17	5.25 [133.35]	6.81 [172.98]	4.94 [125.48]	4.50 [114.30]	4.44 [112.78]	0.31 x 0.81 [7.88 x 20.58]	5.56 [141.23]	8.31 [211.08]	23.6 [10.7]	PFK3

*Secondary fuse clips, fuse clip mounting screws and primary and secondary voltage links/jumpers supplied standard with transformers.

*Dimensions in Inches [mm]
Weight in Lbs. [kg]

Please refer to page 11 for dimensional drawings. Special voltages and VA sizes available upon request.

GROUP F

PRIMARY VOLTAGE: **120 X 240** 115 X 230 110 X 220 50/60 HZ
 SECONDARY VOLTAGE: **120 X 240** 115 X 230 110 X 220

VA Rating	Catalog Number	Mtg. Fig.	Output Amps	Overall Dimensions*			Mounting Centers*		Mounting Slot*	Height with Finger Guard*	Depth with Finger Guard*	Approx. Ship Weight Lbs.*	Opt. Pri. Fuse Kit P/N
				A	B	C	D	E	G X H				
50	PH50PP	A	0.42/0.21	3.00 [76.20]	4.38 [111.26]	3.19 [81.03]	2.50 [63.50]	2.25 [57.15]	0.22 x 0.44 [5.59 x 11.18]	4.00 [101.60]	5.82 [147.83]	3.5 [1.6]	PFK1
75	PH75PP	A	0.63/0.31	3.25 [82.55]	3.88 [98.56]	3.56 [90.43]	2.63 [66.81]	2.50 [63.50]	0.22 x 0.44 [5.59 x 11.18]	4.37 [111.00]	5.32 [135.13]	3.5 [1.6]	PFK1
100	PH100PP	A	0.83/0.42	3.25 [82.55]	4.19 [106.43]	3.63 [92.21]	2.63 [66.81]	2.63 [66.81]	0.22 x 0.44 [5.59 x 11.18]	4.50 [114.30]	5.63 [143.01]	4.5 [2.1]	PFK1
150	PH150PP	B	1.25/0.63	4.00 [101.60]	4.94 [125.48]	3.81 [96.78]	3.38 [85.86]	2.75 [69.85]	0.22 x 0.75 [5.59 x 19.05]	4.50 [114.30]	6.44 [163.58]	5.7 [2.6]	PFK2
250	PH250PP	B	2.08/1.04	4.50 [114.30]	5.44 [138.18]	3.81 [96.78]	3.75 [95.25]	3.13 [79.51]	0.22 x 0.75 [5.59 x 19.05]	4.50 [114.30]	6.94 [176.28]	7.5 [3.4]	PFK2
350	PH350PP	B	2.92/1.46	4.50 [114.30]	5.19 [131.83]	4.44 [112.78]	3.75 [95.25]	3.75 [95.25]	0.22 x 0.75 [5.59 x 19.05]	5.18 [131.58]	6.69 [169.93]	10.1 [4.6]	PFK3
500	PH500PP	B	4.17/2.08	4.75 [120.65]	5.94 [150.88]	4.31 [109.48]	4.06 [103.13]	3.81 [96.78]	0.31 x 0.94 [7.88 x 23.88]	5.13 [130.31]	7.44 [188.98]	14.2 [6.4]	PFK3
750	PH750PP	B	6.25/3.13	5.13 [130.31]	6.69 [169.93]	4.31 [109.48]	4.38 [111.26]	4.31 [109.48]	0.31 x 0.81 [7.88 x 20.58]	5.01 [130.31]	8.19 [208.03]	16.6 [7.5]	PFK3
1000	PH1000PP	B	8.33/4.17	5.25 [133.35]	6.81 [172.98]	4.94 [125.48]	4.50 [114.30]	4.44 [112.78]	0.31 x 0.81 [7.88 x 20.58]	5.56 [141.23]	8.31 [211.08]	23.6 [10.7]	PFK3
1500	PH1500PP	B	12.5/6.25	5.25 [133.35]	8.19 [208.03]	4.94 [125.48]	4.50 [114.30]	6.06 [153.93]	0.38 x 1.0 [9.66 x 25.4]	5.56 [141.23]	9.69 [246.13]	32.0 [14.4]	PFK3

*Secondary fuse clips, fuse clip mounting screws and primary and secondary voltage links/jumpers supplied with transformers.
Please refer to page 11 for dimensional drawings. Special voltages and VA sizes available upon request.

*Dimensions in Inches [mm]
Weight in Lbs. [kg]

SELECTION TABLES

HPS LEGACY CONTROL MOLDED STYLE

GROUP G

PRIMARY VOLTAGE: **120 X 240** 115 X 230 110 X 220 50/60 HZ
 SECONDARY VOLTAGE: **12 X 24** 11.5 X 23 11 X 22

VA Rating	Catalog Number	Mtg. Fig.	Output Amps	Overall Dimensions*			Mounting Centers*		Mounting Slot*	Height with Finger Guard*	Depth with Finger Guard*	Approx. Ship Weight Lbs.*	Opt. Pri. Fuse Kit P/N
				A	B	C	D	E	G X H				
50	PH50PG	A	4.17/2.08	3.00 [76.20]	4.38 [111.26]	3.19 [81.03]	2.50 [63.50]	2.25 [57.15]	0.22 x 0.44 [5.59 x 11.18]	4.00 [101.60]	5.82 [147.83]	3.5 [1.6]	PFK1
75	PH75PG	A	6.25/3.13	3.25 [82.55]	3.88 [98.56]	3.56 [90.43]	2.63 [66.81]	2.50 [63.50]	0.22 x 0.44 [5.59 x 11.18]	4.37 [111.00]	5.32 [135.13]	3.5 [1.6]	PFK1
100	PH100PG	A	8.33/4.17	3.25 [82.55]	4.19 [106.43]	3.63 [92.21]	2.63 [66.81]	2.63 [66.81]	0.22 x 0.44 [5.59 x 11.18]	4.44 [112.78]	5.63 [143.01]	4.5 [2.1]	PFK1
150	PH150PG	B	12.5/6.25	4.00 [101.60]	4.94 [125.48]	3.81 [96.78]	3.38 [85.86]	2.75 [69.85]	0.22 x 0.75 [5.59 x 19.05]	4.50 [114.30]	6.44 [163.58]	5.7 [2.6]	PFK2
250	PH250PG	B	20.8/10.4	4.50 [114.30]	5.44 [138.18]	3.81 [96.78]	3.75 [95.25]	3.13 [79.51]	0.22 x 0.75 [5.59 x 19.05]	4.50 [114.30]	6.94 [176.28]	7.5 [3.4]	PFK2
350	PH350PG	B	29.2/14.6	4.50 [114.30]	5.19 [131.83]	4.44 [112.78]	3.75 [95.25]	3.75 [95.25]	0.22 x 0.75 [5.59 x 19.05]	5.18 [131.58]	6.69 [169.93]	10.1 [4.6]	PFK3
500	PH500PG	B	41.7/20.8	4.75 [120.65]	5.94 [150.88]	4.31 [109.48]	4.06 [103.13]	3.81 [96.78]	0.31 x 0.94 [7.88 x 23.88]	5.13 [130.31]	7.44 [188.98]	14.2 [6.4]	PFK3
750	PH750PG	C	62.5/31.3	5.25 [133.35]	6.25 [158.75]	4.94 [125.48]	4.38 [111.26]	4.31 [109.48]	0.31 x 0.81 [7.88 x 20.58]	5.56 [141.23]	7.88 [200.16]	16.6 [7.5]	PFK3
1000	PH1000PG	C	83.3/41.7	5.25 [133.35]	6.81 [172.98]	4.94 [125.48]	4.50 [114.30]	4.44 [112.78]	0.31 x 0.81 [7.88 x 20.58]	5.56 [141.23]	8.31 [211.08]	23.6 [10.7]	PFK3

*Secondary fuse clips, fuse clip mounting screws and primary and secondary voltage links/jumpers supplied standard with transformers.

*Dimensions in Inches [mm]
Weight in Lbs. [kg]

Please refer to page 11 for dimensional drawings. Special voltages and VA sizes available upon request.

GROUP H

PRIMARY VOLTAGE: **600/480/240** **575/460/230** 550/440/220 50/60 HZ
 SECONDARY VOLTAGE: **120/100** **115/95** 110/90

VA Rating	Catalog Number	Mtg. Fig.	Output Amps	Overall Dimensions*			Mounting Centers*		Mounting Slot*	Height with Finger Guard*	Depth with Finger Guard*	Approx. Ship Weight Lbs.*	Opt. Pri. Fuse Kit P/N
				A	B	C	D	E	G X H				
50	PH50MBMH	A	0.43	3.25 [82.55]	4.06 [103.13]	3.63 [92.21]	2.63 [66.81]	2.63 [66.81]	0.22 x 0.44 [5.59 x 11.18]	4.50 [114.30]	5.50 [139.70]	4.1 [1.9]	PFK5
75	PH75MBMH	A	0.65	3.25 [82.55]	4.19 [106.43]	3.63 [92.21]	2.63 [66.81]	2.63 [66.81]	0.22 x 0.44 [5.59 x 11.18]	4.50 [114.30]	5.63 [143.01]	4.5 [2.1]	PFK5
100	PH100MBMH	B	0.87	4.00 [101.60]	4.63 [117.61]	3.81 [96.78]	3.38 [85.86]	2.75 [69.85]	0.22 x 0.75 [5.59 x 19.05]	4.50 [114.30]	6.25 [158.75]	4.9 [2.3]	PFK6
150	PH150MBMH	B	1.30	4.00 [101.60]	5.44 [138.18]	3.81 [96.78]	3.38 [85.86]	2.75 [69.85]	0.22 x 0.75 [5.59 x 19.05]	4.50 [114.30]	6.94 [176.28]	7.6 [3.5]	PFK6
250	PH250MBMH	B	2.17	4.50 [114.30]	5.19 [131.83]	4.44 [112.78]	3.75 [95.25]	3.75 [95.25]	0.22 x 0.75 [5.59 x 19.05]	5.18 [131.58]	6.69 [169.93]	10.1 [4.6]	PFK6
350	PH350MBMH	B	3.04	4.50 [114.30]	5.56 [141.23]	4.44 [112.78]	3.75 [95.25]	3.75 [95.25]	0.22 x 0.75 [5.59 x 19.05]	5.18 [131.58]	7.06 [179.33]	11.0 [5.0]	PFK7
500	PH500MBMH	B	4.35	4.75 [120.65]	6.69 [169.93]	4.31 [109.48]	4.06 [103.13]	4.50 [114.30]	0.31 x 0.94 [7.88 x 23.88]	5.13 [130.31]	8.19 [208.03]	16.3 [7.4]	PFK7
750	PH750MBMH	B	6.52	5.25 [133.35]	6.81 [172.98]	4.94 [125.48]	4.50 [114.30]	4.44 [112.78]	0.31 x 0.81 [7.88 x 20.58]	5.56 [141.23]	8.31 [211.08]	23.6 [10.7]	PFK7
1000	PH1000MBMH	B	8.70	5.30 [134.62]	7.80 [198.12]	4.90 [124.46]	4.50 [114.30]	6.11 [155.20]	0.38 x 1.0 [9.66 x 25.4]	5.60 [142.24]	9.70 [246.38]	31.2 [14.1]	PFK7
1500	PH1500MBMH	B	13.0	5.30 [134.62]	8.19 [208.03]	4.94 [125.48]	4.50 [114.30]	6.06 [153.93]	0.38 x 1.0 [9.66 x 25.4]	5.56 [141.23]	9.69 [246.13]	32.0 [14.4]	PFK7

*Secondary fuse clips, fuse clip mounting screws and primary and secondary voltage links/jumpers supplied with transformers.
Please refer to page 11 for dimensional drawings. Special voltages and VA sizes available upon request.

*Dimensions in Inches [mm]
Weight in Lbs. [kg]

SELECTION TABLES

HPS LEGACY CONTROL MOLDED STYLE

GROUP I

PRIMARY VOLTAGE: 480/240 460/230/208 440/220/220 50/60 HZ
 SECONDARY VOLTAGE: 120/25 115/24 110/23

VA Rating	Catalog Number	Mtg. Fig.	Output Amps	Overall Dimensions*			Mounting Centers*		Mounting Slot*	Height with Finger Guard*	Depth with Finger Guard*	Approx. Ship Weight Lbs.*	Opt. Pri. Fuse Kit P/N
				A	B	C	D	E					
50	PH50MLI	A	0.43/2.08	3.25 [82.55]	4.06 [103.13]	3.56 [90.43]	2.63 [66.81]	2.50 [63.50]	0.22 x 0.44 [5.59 x 11.18]	4.37 [111.00]	5.50 [139.70]	4.0 [1.8]	PFK5
75	PH75MLI	A	0.65/3.13	3.25 [82.55]	4.25 [107.95]	3.56 [90.43]	2.63 [66.81]	2.50 [63.50]	0.22 x 0.44 [5.59 x 11.18]	4.37 [111.00]	5.69 [144.53]	4.6 [2.1]	PFK5
100	PH100MLI	A	0.87/4.17	3.25 [82.55]	4.69 [119.13]	3.63 [92.21]	2.63 [66.81]	2.63 [66.81]	0.22 x 0.44 [5.59 x 11.18]	4.50 [114.30]	6.25 [158.75]	5.2 [2.4]	PFK5
150	PH150MLI	B	1.30/6.25	4.00 [101.60]	5.44 [138.18]	3.81 [96.78]	3.38 [85.86]	2.75 [69.85]	0.22 x 0.75 [5.59 x 19.05]	4.50 [114.30]	6.94 [176.28]	7.6 [3.5]	PFK6
250	PH250MLI	B	2.17/10.42	4.50 [114.30]	5.19 [131.83]	4.44 [112.78]	3.75 [95.25]	3.75 [95.25]	0.22 x 0.75 [5.59 x 19.05]	5.18 [131.58]	6.69 [169.93]	10.1 [4.6]	PFK6
350	PH350MLI	B	3.04/14.58	4.50 [114.30]	5.56 [141.23]	4.44 [112.78]	3.75 [95.25]	3.75 [95.25]	0.22 x 0.75 [5.59 x 19.05]	5.18 [131.58]	7.06 [179.33]	11.0 [5.0]	PFK7
500	PH500MLI	B	4.35/20.83	4.75 [120.65]	6.69 [169.93]	4.31 [109.48]	4.06 [103.13]	4.50 [114.30]	0.31 x 0.94 [7.88 x 23.88]	5.13 [130.31]	8.19 [208.03]	16.3 [7.4]	PFK7
750	PH750MLI	C	6.52/31.25	5.25 [133.35]	6.50 [165.10]	4.94 [125.48]	4.50 [114.30]	4.13 [104.91]	0.31 x 0.81 [7.88 x 20.58]	5.56 [141.23]	8.31 [211.08]	21.0 [9.5]	PFK7
1000	PH1000MLI	C	8.70/41.67	5.25 [133.35]	8.19 [208.03]	4.94 [125.48]	4.50 [114.30]	5.81 [147.58]	0.31 x 0.81 [7.88 x 20.58]	5.56 [141.23]	9.69 [246.13]	31.2 [14.1]	PFK7

*Secondary fuse clips, fuse clip mounting screws and primary and secondary voltage links/jumpers supplied standard with transformers.

*Dimensions in Inches [mm]
Weight in Lbs. [kg]

Please refer to page 11 for dimensional drawings. Special voltages and VA sizes available upon request.

GROUP J

PRIMARY VOLTAGE: 415/400/380 50/60 HZ
 SECONDARY VOLTAGE: 110 X 220

VA Rating	Catalog Number	Mtg. Fig.	Output Amps	Overall Dimensions*			Mounting Centers*		Mounting Slot*	Height with Finger Guard*	Depth with Finger Guard*	Approx. Ship Weight Lbs.*	Opt. Pri. Fuse Kit P/N
				A	B	C	D	E					
50	PH50MEMX	A	0.45/0.23	3.00 [76.20]	4.38 [111.26]	3.19 [81.03]	2.50 [63.50]	2.25 [57.15]	0.22 x 0.44 [5.59 x 11.18]	4.00 [101.60]	5.82 [147.83]	3.5 [1.6]	PFK4
75	PH75MEMX	A	0.68/0.34	3.25 [82.55]	4.06 [103.13]	3.63 [92.21]	2.63 [66.81]	2.63 [66.81]	0.22 x 0.44 [5.59 x 11.18]	4.44 [112.78]	5.50 [139.70]	4.1 [1.9]	PFK5
100	PH100MEMX	A	0.91/0.45	3.25 [82.55]	4.19 [106.43]	3.63 [92.21]	2.63 [66.81]	2.63 [66.81]	0.22 x 0.44 [5.59 x 11.18]	4.44 [112.78]	5.63 [143.01]	4.5 [2.1]	PFK5
150	PH150MEMX	B	1.36/0.68	4.00 [101.60]	4.94 [125.48]	3.81 [96.78]	3.38 [85.86]	2.75 [69.85]	0.22 x 0.75 [5.59 x 19.05]	4.50 [114.30]	6.44 [163.58]	5.7 [2.6]	PFK6
250	PH250MEMX	B	2.27/1.14	4.50 [114.30]	5.44 [138.18]	3.81 [96.78]	3.75 [95.25]	3.13 [79.51]	0.22 x 0.75 [5.59 x 19.05]	4.50 [114.30]	6.94 [176.28]	7.5 [3.4]	PFK6
350	PH350MEMX	B	3.18/1.59	4.50 [114.30]	5.19 [131.83]	4.44 [112.78]	3.75 [95.25]	3.75 [95.25]	0.22 x 0.75 [5.59 x 19.05]	5.18 [131.58]	6.69 [169.93]	10.1 [4.6]	PFK7
500	PH500MEMX	B	4.55/2.27	4.75 [120.65]	5.94 [150.88]	4.31 [109.48]	4.06 [103.13]	3.81 [96.78]	0.31 x 0.94 [7.88 x 23.88]	5.13 [130.31]	7.44 [188.98]	14.2 [6.4]	PFK7
750	PH750MEMX	B	6.82/3.41	5.25 [133.35]	6.50 [165.10]	4.94 [125.48]	4.50 [114.30]	4.13 [104.91]	0.31 x 0.81 [7.88 x 20.58]	5.56 [141.23]	8.00 [203.20]	21.0 [9.5]	PFK7
1000	PH1000MEMX	B	9.09/4.55	5.25 [133.35]	6.81 [172.98]	4.94 [125.48]	4.50 [114.30]	4.44 [112.78]	0.31 x 0.81 [7.88 x 20.58]	5.56 [141.23]	8.31 [211.08]	23.6 [10.7]	PFK7

*Secondary fuse clips, fuse clip mounting screws and primary and secondary voltage links/jumpers supplied with transformers. Please refer to page 11 for dimensional drawings. Special voltages and VA sizes available upon request.

*Dimensions in Inches [mm]
Weight in Lbs. [kg]

SELECTION TABLES

HPS LEGACY CONTROL MOLDED STYLE

GROUP K

PRIMARY VOLTAGE: **380/277/208**
 SECONDARY VOLTAGE: **120 X 240**

50/60 HZ

VA Rating	Catalog Number	Mtg. Fig.	Output Amps	Overall Dimensions*			Mounting Centers*		Mounting Slot*	Height with Finger Guard*	Depth with Finger Guard*	Approx. Ship Weight Lbs.*	Opt. Pri. Fuse Kit P/N
				A	B	C	D	E	G X H				
50	PH50MGJ	A	0.42/0.21	3.25 [82.55]	3.88 [98.56]	3.56 [90.43]	2.63 [66.81]	2.50 [63.50]	0.22 x 0.44 [5.59 x 11.18]	4.37 [111.00]	5.32 [135.13]	3.5 [1.6]	PFK5
75	PH75MGJ	A	0.63/0.31	3.25 [82.55]	4.19 [106.43]	3.63 [92.21]	2.63 [66.81]	2.63 [66.81]	0.22 x 0.44 [5.59 x 11.18]	4.44 [112.78]	5.63 [143.01]	4.5 [2.1]	PFK5
100	PH100MGJ	A	0.83/0.42	3.25 [82.55]	4.69 [119.13]	3.63 [92.21]	2.63 [66.81]	2.63 [66.81]	0.22 x 0.44 [5.59 x 11.18]	4.50 [114.30]	6.13 [155.71]	5.2 [2.4]	PFK5
150	PH150MGJ	B	1.25/0.63	4.00 [101.60]	5.44 [138.18]	3.81 [96.78]	3.38 [85.86]	2.75 [69.85]	0.22 x 0.75 [5.59 x 19.05]	4.50 [114.30]	6.94 [176.28]	7.6 [3.5]	PFK6
250	PH250MGJ	B	2.08/1.04	4.50 [114.30]	4.88 [123.96]	4.44 [112.78]	3.75 [95.25]	3.75 [95.25]	0.22 x 0.75 [5.59 x 19.05]	5.18 [131.58]	6.38 [162.06]	8.3 [3.8]	PFK6
350	PH350MGJ	B	2.92/1.46	4.50 [114.30]	5.56 [141.23]	4.44 [112.78]	3.75 [95.25]	3.75 [95.25]	0.22 x 0.75 [5.59 x 19.05]	5.18 [131.58]	7.06 [179.33]	11.0 [5.0]	PFK7
500	PH500MGJ	B	4.17/2.08	4.75 [120.65]	6.69 [169.93]	4.31 [109.48]	4.06 [103.13]	4.50 [114.30]	0.31 x 0.94 [7.88 x 23.88]	5.13 [130.31]	8.19 [208.03]	16.3 [7.4]	PFK7
750	PH750MGJ	B	6.25/3.13	5.25 [133.35]	6.81 [172.98]	4.94 [125.48]	4.50 [114.30]	4.44 [112.78]	0.31 x 0.81 [7.88 x 20.58]	5.56 [141.23]	8.31 [211.08]	23.6 [10.7]	PFK7
1000	PH1000MGJ	B	8.33/4.17	5.25 [133.35]	7.25 [184.15]	4.94 [125.48]	4.50 [114.30]	4.83 [122.69]	0.31 x 0.81 [7.88 x 20.58]	5.44 [138.18]	8.75 [222.25]	25.5 [11.5]	PFK7

*Secondary fuse clips, fuse clip mounting screws and primary and secondary voltage links/jumpers supplied standard with transformers.

*Dimensions in Inches [mm]
Weight in Lbs. [kg]

Please refer to page 11 for dimensional drawings. Special voltages and VA sizes available upon request.

Accessory Kits Available

Standard Secondary Fuse Kits

All HPS legacy control molded style transformers are supplied with standard secondary fuse kits which include: 13/32" x 1/2" midget/ type CC fuse clips, fuse clip mounting screws, primary and secondary voltage links and the PHAK1 instruction sheet (note: secondary fuse clips and fuse clip mounting screws not supplied on the PH750PG, PH1000PG, PH750MLI and PH1000MLI). Please consult the HPS Transformer Products catalog for additional details.

Optional Primary Fuse Kits

Kit Part Number	Transformer Part Number Suffix's	VA Sizes	Parts Included in Kit
PFK1	Refer to Specification Tables on pages 4 to 7	Refer to Specification Tables on pages 4 to 7	4 fuse clips, 4 mtg. screws, PHAK1 instruction sheet
PFK2			4 fuse clips, 4 mtg. screws, PHAK1 instruction sheet
PFK3			4 fuse clips, 4 mtg. screws, PHAK1 instruction sheet
PFK4			4 fuse clips, 4 mtg. screws, 1 jumper, 1 finger guard, PHAK1 instruction sheet
PFK5			4 fuse clips, 4 mtg. screws, 1 jumper, 1 finger guard, PHAK1 instruction sheet
PFK6			4 fuse clips, 4 mtg. screws, 1 jumper wire, PHAK1 instruction sheet
PFK7			4 fuse clips, 4 mtg. screws, 1 jumper wire, PHAK1 instruction sheet

Note: Maximum allowable current rating on all primary and secondary fuse kits is 30 amps.

Legacy Control Molded Style

Factory Installed Primary and Secondary Fuse Kits

HPS now stocks some HPS legacy control molded style voltage groups with FACTORY INSTALLED primary and secondary fuse clips. To order, just add the suffix “-FK” to the end of the standard part number.

Factory installed primary and secondary fuse clips are only available on the following voltage groups:

Group C (p/n: PH*MQMJ-FK) | Group G (p/n: PH***PG-FK) | Group I (p/n: PH***MLI-FK)**

On PH750PG-FK, PH1000PG-FK, PH750MLI-FK, and PH1000MLI-FK, only primary fuse clips are included on factory installed units. Secondary fuse clips are not included or available on these units.

Note: All factory installed fuse kits are pre-wired at the transformers highest primary voltage and the lowest secondary voltage. To hook up at a different primary or secondary voltage, please refer to the wiring instruction sheet included with the transformer.

Optional Unfused Finger Guard Kits

Kit Part Number	Transformer Part Number Suffix's	VA Sizes	Parts Included in Kit
FG1	AJ, AR, MQMJ, MEMX, QR, SP, PG, PP	50	1 finger guard (unfused), PHAK1 instruction sheet
FG2	MBMH, MGJ, MLI	50	1 finger guard (unfused), PHAK1 instruction sheet
FG2	All	75	1 finger guard (unfused), PHAK1 instruction sheet
FG2	All (excluding PH100MBMH)	100	1 finger guard (unfused), PHAK1 instruction sheet
	Refer to FG3, FG4 or FG5 below	150 to 1500	

Optional Fused Finger Guard Kits

Kit Part Number	Transformer Part Number Suffix's	VA Sizes	Parts Included in Kit
FGF1	AJ, AR, MQMJ, MEMX, QR, SP, PG, PP	50	1 finger guard (fused), PHAK1 instruction sheet
FGF2	MBMH, MGJ, MLI	50	1 finger guard (fused), PHAK1 instruction sheet
FGF2	All	75	1 finger guard (fused), PHAK1 instruction sheet
FGF2	All (excluding PH100MBMH)	100	1 finger guard (fused), PHAK1 instruction sheet
FG3	MBMH	100	1 finger guard, PHAK1 instruction sheet
FG3	All	150	1 finger guard, PHAK1 instruction sheet
FG3	AJ, AR, MQMJ, MEMX, QR, SP, PG, PP	250	1 finger guard, PHAK1 instruction sheet
FG4	MBMH, MGJ, MLI	250	1 finger guard, PHAK1 instruction sheet
FG4	All	350, 500	1 finger guard, PHAK1 instruction sheet
FG4	AJ, AR, MQMJ, QR, SP, PP	750	1 finger guard, PHAK1 instruction sheet
FG5	MBMH, MEMX, MGJ, MLI, PG	750	1 finger guard, PHAK1 instruction sheet
FG5	All	1000, 1500	1 finger guard, PHAK1 instruction sheet



Sample Accessory Drawings

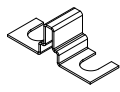

Voltage Link

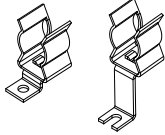

Fuse Clips
(For 50, 75 and 100VA)

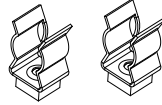

Fuse Clips
(For 150VA to 1500VA)

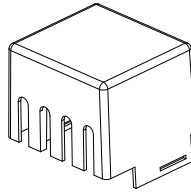

Fused & Unfused Finger Guard
(For 50, 75 and 100VA)

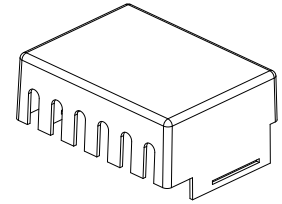
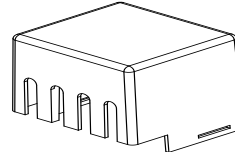

Finger Guard
(For 150VA to 1500VA)

Sample Accessory Assembly Drawings

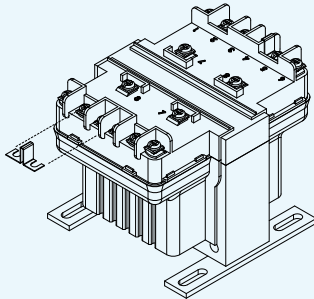

**Sample Assembly Drawing for
Voltage Link Installation**

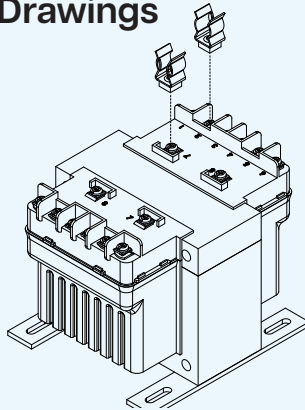

**Sample Assembly Drawing for
Secondary Fuse Clip Installation**
(For 150VA to 1500VA)

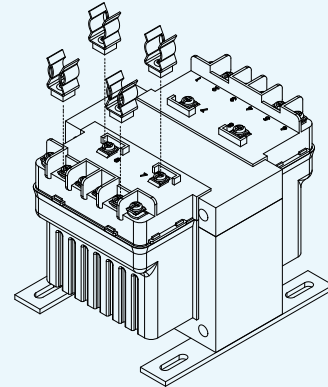

**Sample Assembly Drawing for
Primary Fuse Clip Installation**
(For 150VA to 1500VA)

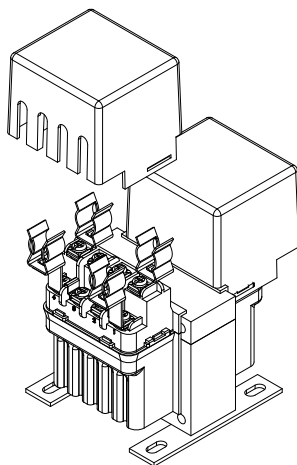

**Sample Assembly Drawing for
Finger Guard Installation**
(For 50, 75 and 100VA)

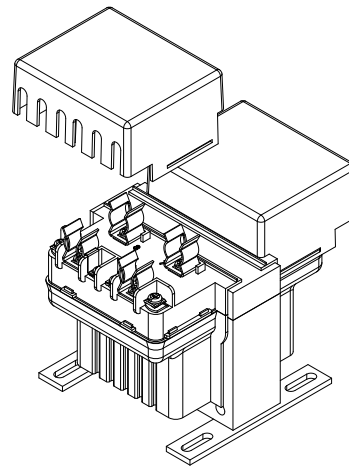

**Sample Assembly Drawing for
Finger Guard Installation**
(For 150VA to 1500VA)

Legacy Control Molded Style

Overcurrent Protection

Secondary

The overcurrent protection listed below, in amperes, is 125% of the rated current of the transformer. Choose the next higher fuse rating if these numbers do not correspond with standard fuse selections.

Sec. Voltage	VA Rating															
	25	50	75	100	150	200	250	300	350	500	750	1000	1500	2000	3000	5000
12	2.7	5.3	7.9	11	16	21	27	-	-	-	-	-	-	-	-	-
24	1.4	2.7	4.0	5.3	7.9	11	14	16	19	27	-	-	-	-	-	-
90	0.4	0.7	1.1	1.4	2.1	2.8	3.5	4.2	4.9	7.0	11	14	21	28	-	-
95	0.4	0.7	1.0	1.4	2.0	2.7	3.3	4.0	4.7	6.6	9.9	14	20	27	-	-
100	0.4	0.7	1.0	1.3	1.9	2.5	3.2	3.8	4.4	6.3	9.4	13	19	25	-	-
110	0.3	0.6	0.9	1.2	1.8	2.3	2.9	3.5	4.0	5.7	8.6	12	18	23	-	-
115	0.3	0.6	0.9	1.1	1.7	2.2	2.8	3.3	3.9	5.5	8.2	11	17	22	-	-
120	0.3	0.6	0.8	1.1	1.6	2.1	2.7	3.2	3.7	5.3	7.9	11	16	21	-	-
220	0.15	0.3	0.5	0.6	0.9	1.2	1.5	1.8	2.0	2.9	4.3	5.7	8.6	12	18	29
230	0.14	0.3	0.5	0.6	0.9	1.1	1.4	1.7	2.0	2.8	4.1	5.5	8.2	11	17	28
240	0.14	0.3	0.4	0.6	0.8	1.1	1.4	1.6	1.9	2.7	4.0	5.3	7.9	11	16	27

Primary

To assist in the selection of fuses, the following chart suggests the maximum primary fuse rating in amperes. The number shown is the maximum overcurrent protection when the primary current is less than 2 amps and the overcurrent protection device is rated for 300%. Choose the next higher fuse rating if these numbers do not correspond with standard fuse selections.

Pri. Voltage	VA Rating																
	25	50	75	100	150	200	250	300	350	500	750	1000	1500	2000	3000	5000	7500
115	0.6	1.25	1.8	2.5	3.5	5	4	5	5	8	10	15	20	25	-	-	-
120	0.6	1.25	1.8	2.25	3.5	5	4	5	5	8	10	15	15	20	-	-	-
200	0.3	0.75	1.125	1.5	2.25	3	3.5	4.5	5	4.5	7	9	15	15	20	-	-
208	0.3	0.6	1	1.4	2	2.8	3.5	4	5	4	6	8	12	15	20	30	-
220	0.3	0.6	1	1.25	2	2.5	3.2	4	4.5	4	6	8	12	15	20	30	-
230	0.3	0.6	0.8	1.25	1.8	2.5	3.2	3.5	4.5	4	6	8	10	15	20	30	-
240	0.3	0.6	0.8	1.25	1.8	2.25	3	3.5	4	3.5	5	7	10	15	15	30	-
277	0.25	0.5	0.8	1	1.6	2	2.5	3.2	3.5	5	5	6	9	12	15	25	-
347	0.25	0.5	0.8	1	1.6	2	2.5	3.2	3.5	5	6.25	5	7.5	10	15	20	30
380	0.1875	0.3	0.5	0.75	1.125	1.5	1.8	2.25	2.5	3.5	5.6	4.5	6.25	9	15	20	25
400	0.1875	0.3	0.5	0.75	1.125	1.5	1.8	2.25	2.5	3.5	5.6	4.5	6.25	9	12	15	20
416	0.15	0.3	0.5	0.6	1	1.4	1.8	2	2.5	3.5	5	4	6	8	12	15	20
440	0.15	0.3	0.5	0.6	1	1.25	1.6	2	2.25	3.2	5	4	6	8	12	15	20
460	0.15	0.3	0.4	0.6	0.8	1.25	1.6	1.8	2.25	3.2	4.5	3.5	6	8	12	15	20
480	0.15	0.3	0.4	0.6	0.8	1.25	1.5	1.8	2	3	4.5	3.5	5	7	10	15	20
550	0.125	0.25	0.4	0.5	0.8	1	1.25	1.6	1.8	2.5	4	5	4.5	6	9	15	15
575	0.125	0.25	0.3	0.5	0.75	1	1.25	1.5	1.8	2.5	3.5	5	4.5	6	9	15	15
600	0.125	0.2	0.3	0.5	0.75	0.8	1.25	1.5	1.6	2.25	3.5	5	4	6	9	15	15



Dimensional Drawings

Some actual transformer units may differ from dimensional drawings shown below.

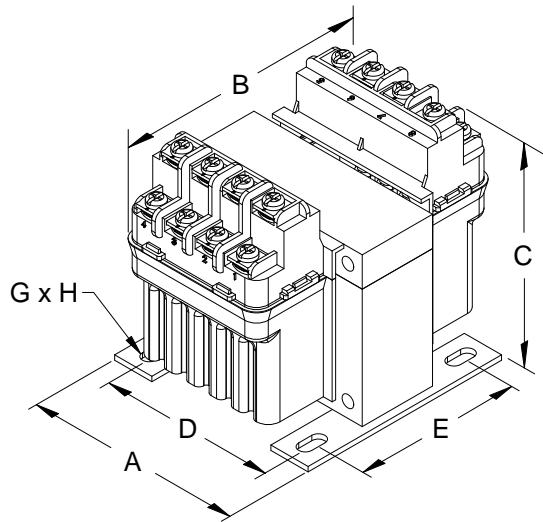

FIGURE A (100 VA and less)

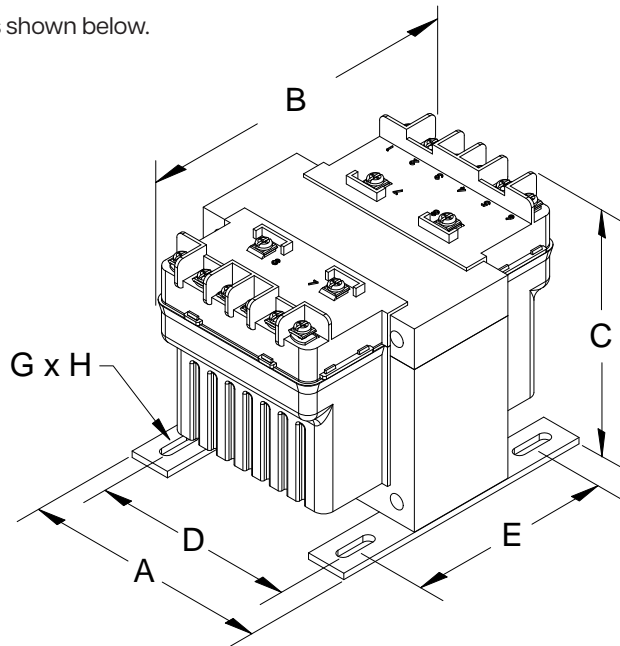

FIGURE B (150 VA to 1500 VA)

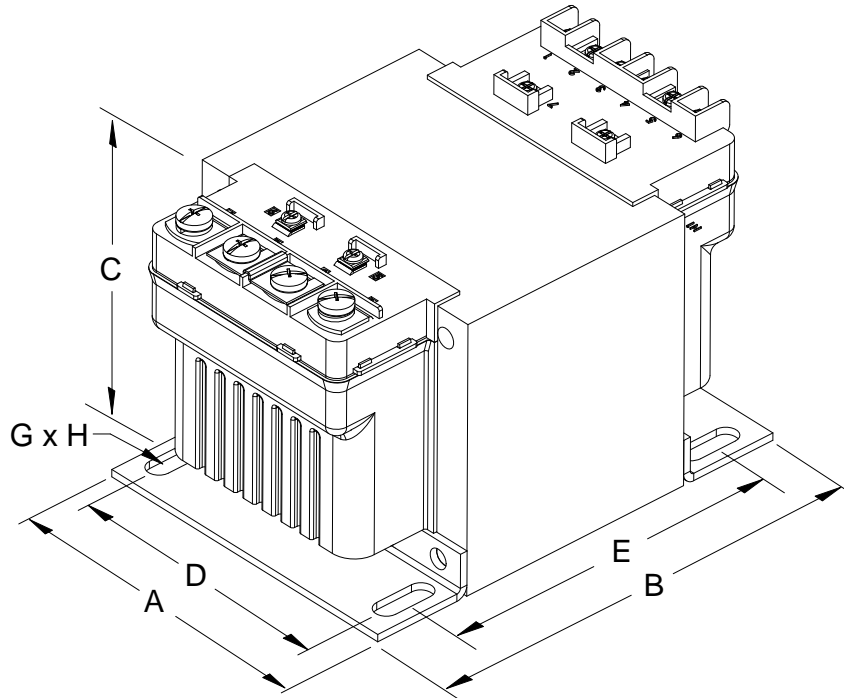

FIGURE C (For PH750PG, PH1000PG, PH750MLI & PH1000MLI)

OTHER DRIVE SOLUTIONS



HPS TruWave™ Active Harmonic Filter

HPS TruWave™ Active Harmonic Filter (AHF) is a comprehensive and flexible solution for harmonic mitigation. It provides advanced control and proven reliability that your facility needs to solve harmonic problems generated by non-linear loads such as variable frequency drives.

The AHF monitors load current and quickly responds to power system distortion as it develops. The AHF injects a corrective current to effectively cancel out harmonics produced by three phase non-linear loads. The result is a reduction in harmonic distortion to below 5%, complying with the IEEE-519 recommendations.



HPS Centurion™ P Passive Harmonic Filter

HPS Centurion™ P passive harmonic filter is specifically engineered to mitigate harmonic currents created by non-linear loads. It is currently available from 5 to 500 horsepower and it improves power quality by simultaneously reducing harmonics and improving true power factor. The advanced HPS design delivers superior performance compared to a traditional harmonic filter by reducing harmonic current distortion to less than 5%, corrects true power factor to over 95%, and meets IEEE 519 harmonic requirements.

HPS Centurion P consists of reactors and capacitors in an LCL arrangement designed to reduce a broad range of harmonics associated with variable frequency drives and other three phase rectifiers.

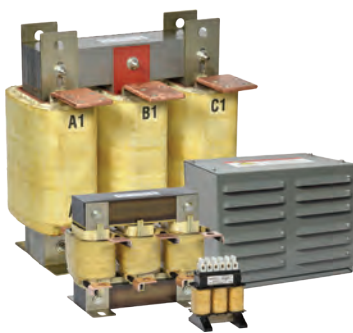

HPS Centurion™ R Reactor

The HPS Centurion™ R reactor provides a U.L. listed solution to many common drive issues.

Line reactor benefits:

- › Minimizes harmonic current
- › Attenuates voltage and current harmonics to reduce voltage notching
- › Improves True Power Factor by reducing overall current distortion
- › Mitigates drive nuisance tripping by attenuating voltage transients from sources such as PFCC, utility switching and lightning

When coordinated with a HPS TruWave Active Harmonic Filter, the system can reduce harmonics from variable frequency drives to under 5% THD.

Load reactor benefits:

- › Reduces the motor's operating temperature & audible noise
- › Mitigates motor bearing failures and insulation damage as a result of the reflected wave phenomenon
- › Enhances the overall performance and life expectancy of the motor





dV/dT Filter

The HPS dV/dT filter provides protection for motors by slowing the rate of voltage increase and minimizing the peak voltage that occurs at the motor's terminals and along the cables feeding the motor.

It does this by combining the harmonic current limiting ability of an AC line reactor plus a resistive capacitance circuit that forms a damped, low pass filter.

HPS dV/dT filters are specifically designed for drive/motor applications with long lead lengths (usually where the motor cable length is 100 feet and greater).



Energy Efficient Drive Isolation Transformers

HPS Tribune™ drive isolation transformers are suitable for both AC and DC variable speed drives. They are sized to match standard motor horsepower and voltage ratings.

Standard features include:

- › Meets NRCAN 2019
- › Three phase ratings from 7 kVA to 660 kVA
- › Available in aluminum, copper and optional shield
- › UL Listed and CSA Certified
- › Type 3R enclosure (optional Type 4, 12 or stainless)



HPS Multi-Pulse Transformer

Multi-Pulse transformers are designed specifically for harmonics, voltage distortion and other unique characteristics associated with individual manufacturer's drive systems. They provide the required supply voltage with the desired phase angle between secondary voltages for VFD systems/converters.

- › HPS has significant experience with 18, 24, 36, 48 pulse drive/inverter duty transformers and auto-transformers in both low and medium voltage applications.

Typical Drive Current Waveforms

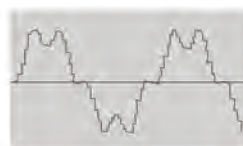

6 Pulse Rectifier



18 Pulse Rectifier

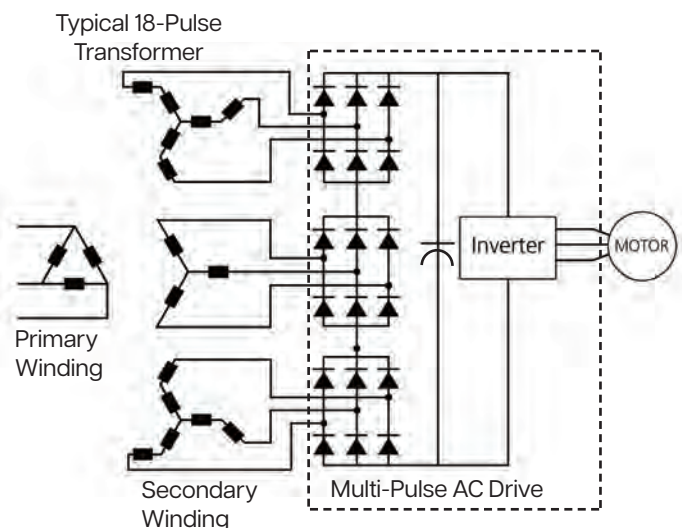



CANADA

Hammond Power Solutions

595 Southgate Drive
Guelph, Ontario N1G 3W6
Tel: (519) 822-2441 | Fax: (519) 822-9701
Toll Free: 1-888-798-8882

sales@hammondpowersolutions.com



UNITED STATES

Hammond Power Solutions

1100 Lake Street
Baraboo, Wisconsin 53913-2866
Tel: (608) 356-3921 | Fax: (608) 355-7623
Toll Free: 1-866-705-4684

sales@hammondpowersolutions.com



MEXICO

Hammond Power Solutions Latin America S.

Av. No. 800,
Parque Industrial Guadalupe
Guadalupe, NL, Mexico, C.P. 67190.
Tel: (819) 690-8000

sales@hammondpowersolutions.com



ASIA

Hammond Power Solutions Pvt. Ltd.

Plot No 6A, Phase -1, IDA,
Pashamylaram, Patancheru (M)
Sangareddy, 502 307, India
Tel: +91-994-995-0009

marketing-india@hammondpowersolutions.com

EMEA (SALES OFFICE)

Hammond Power Solutions SpA

Tel: +49 (152) 08800468

sales-emea@hammondpowersolutions.com



hammondpowersolutions.com



IMPESP-BBH2-EN
July 2023