

hammond  
POWER SOLUTIONS



# HPS RC-SERIES

dV/dT Filters



[hammondpowersolutions.com](http://hammondpowersolutions.com)

energizing our world

Distributed by Gross Automation | +1 (262) 252-1600 | [sales@grossautomation.com](mailto:sales@grossautomation.com)



## HPS RC-Series dV/dT Filters

The HPS RC series dV/dT filters combine appropriate values of inductance, capacitance and resistance to form a filter which reduces dV/dT and peak voltages from the PWM voltage waveform. When combined with a 3% impedance reactor that will reduce motor heating harmonics, the life of the motor will significantly increase.

The advent of pulse width modulated (PWM) inverters with IGBT high speed transistors has resulted in smaller more cost effective drives and increased switching speeds. A waveform with increased harmonics at higher frequencies is the result of these much faster switching devices, usually at frequencies of 10,000 to 20,000 Hertz.

Drives and motors often need to be separated by significant distances. For deep wells or mines, the motors are usually controlled on the surface. As a result, the distance between the drive and the motor creates long motor lead lengths. In some plant applications, the motors can withstand the harsh environment, but the sensitive variable frequency drive cannot.

dV/dT is explained as the steep-front voltage pulses that travel down these long leads in the circuit to the motor and subsequently reverted back in a “reflective wave”. When the conductors are long enough, usually 20 feet or more, the time for reflection matches the time for transmission resulting in a high amplitude ‘standing wave’ on the circuit. Voltage spikes of up to 2100 volts are frequently experienced for 600 volt systems and motor winding failures are the result. Long lead length motor drive applications can experience motor terminal peak voltage spikes twice the DC bus voltage, and higher. Therefore motor terminal voltage peaks of 1200 volts for 480V drives and 1600 volts for 600V drives are not uncommon. The highest peak voltages will typically occur in lower HP applications.

A dV/dT filter, combines the current limiting ability of an AC line reactor plus a resistive capacitance circuit that forms a damped, low pass filter. It provides protection for the motor by slowing the rate of voltage increase and minimizing the peak voltage that occurs at the motor terminals.

The cost of a dV/dT Filter is a little more than the cost of the reactor and can be mounted next to the drive, or inside the PWM enclosure.

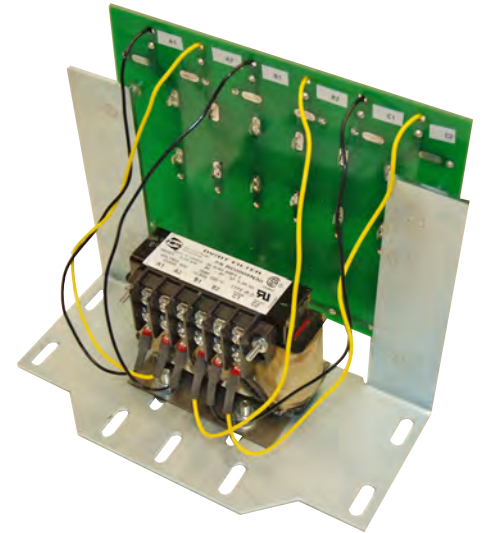

## Applications

The HPS RC series dV/dT filters are specifically designed for drive/motor applications with long lead lengths (usually where the motor cable length is 20 feet or greater). They should always be installed next to the IGBT variable frequency drive.

Typical applications include:



Production Process Lines



Drives



Data Centers



Deep Wells

# SPECIFICATIONS

## Typical Performance



<b>Ratings:</b>	Nominal Inductance +/- 10% @ rated current 95% of nominal inductance @ 150% rated current 50% of nominal inductance @ 350% of rated current	<b>Cooling Method:</b>	Natural convection
<b>UL Listed:</b>	File: E61431	<b>System Voltage:</b>	600 Volts Maximum
<b>CSA Certified:</b>	File: LR3902	<b>Sound Level:</b>	2 to 18 amps: 58 dBA 25 to 100 amps: 64 dBA 130 to 320 amps: 70 dBA 400 to 600 amps: 75 dBA
<b>Frequency:</b>	60 Hz Fundamental Current Maximum	<b>Enclosure (when specified):</b>	Type 2 or Type 3R
<b>Insulation System:</b>	200° C (115° C rise) up to 160 amps (40° C ambient) 220° C (115° C rise) over 160 amps (60° C ambient)	<b>Harmonic Withstand:</b>	HPS dV/dT filters are designed to withstand harmonics associated with the output side of variable speed drives including IGBT type inverters.
		<b>Switching Frequency:</b>	2.5 KHz up to 20 KHz
		<b>Warranty:</b>	10 years

# dV/dT Filter Part Number Guide

### Example

Product Line						Rated Current						Inductance Letter	Inductance Value	Enclosure	Further suffix to follow
R	C	0	0	0	2							M	12	E	*
Product Line: RC - dV/dT Filter												Inductance Letter: 'M' XX. mH 'N' X.X mH 'P' 0.XX mH 'U' .0XX mH or XX.0 uH		Enclosure: E - Enclosed	
Rated Current: Current rating												Inductance Value: Inductance Value			

**Note:** As all characters of the P/N represent performance values of the reactor, P/N's are not completely sequential. They are sorted by current rating.



## Selection Guidelines

HPS RC filters are current rated devices. Therefore, to properly size and select the correct unit for your application, it is necessary to know the total motor load on the inverter. All HPS RC filters are designed to be located next to the output terminals of the drive with symmetrical configured three phase cable used to connect the RC filter to the motor. Placement of these filters anywhere else will negatively impact the units performance.

The dV/dT filters have had the reactor selected in such a manner that the 3% impedance is approximately maintained at both the 600 and 480 system voltage level. Utilizing a 3% reactor provides optimum performance and protection for the motor. Using smaller impedance reactors will not protect against the same current peaks and motor performance would therefore be diminished.

### 600V or 480V, 3% Impedance, 60 Hz

Current (Amps)	Part Number	Inductance	Watts Loss	Approx. Dimensions Inches [mm]					Mtg Slot/ Hole Size	Dim. Fig. #	Encl. Fig. #	Weight Lbs. [Kg]	Enclosed Weight Lbs. [Kg]
				Width	Depth	Height	Mtg. W	Mtg. D					
2	RC0002M12	12.0	62	9.00 [228.60]	6.18 [156.98]	7.40 [187.96]	8.25 [209.55]	2.00 [50.80]	.28 x .88 [7.12 x 22.36]	1	N1	4.0 [1.8]	11.0 [5.0]
4	RC0004N65	6.50	68	9.00 [228.60]	6.18 [156.98]	7.40 [187.96]	8.25 [209.55]	2.00 [50.80]	.28 x .88 [7.12 x 22.36]	1	N1	5.0 [2.3]	12.0 [5.4]
8	RC0008N30	3.00	80	9.00 [228.60]	6.18 [156.98]	7.40 [187.96]	8.25 [209.55]	2.00 [50.80]	.28 x .88 [7.12 x 22.36]	1	N1	5.0 [2.3]	12.0 [5.4]
12	RC0012N25	2.50	81	9.00 [228.60]	6.18 [156.98]	7.40 [187.96]	8.25 [209.55]	2.00 [50.80]	.28 x .88 [7.12 x 22.36]	2	N1	10.0 [4.5]	17.0 [7.7]
18	RC0018N15	1.50	84	9.00 [228.60]	6.18 [156.98]	7.40 [187.96]	8.25 [209.55]	2.00 [50.80]	.28 x .88 [7.12 x 22.36]	2	N1	11.0 [5.0]	18.0 [8.1]
25	RC0025N12	1.20	99	9.00 [228.60]	6.18 [156.98]	7.40 [187.96]	8.25 [209.55]	2.00 [50.80]	.28 x .88 [7.12 x 22.36]	2	N1	12.0 [5.4]	19.0 [8.6]
35	RC0035P80	0.80	106	9.00 [228.60]	6.18 [156.98]	7.40 [187.96]	8.25 [209.55]	2.00 [50.80]	.28 x .88 [7.12 x 22.36]	3	N2	19.0 [8.6]	36.0 [16.2]
45	RC0045P70	0.70	119	9.00 [228.60]	6.42 [163.07]	7.40 [187.96]	8.25 [209.55]	2.00 [50.80]	.28 x .88 [7.12 x 22.36]	3	N2	24.0 [10.8]	41.0 [18.5]
55	RC0055P50	0.50	130	9.00 [228.60]	6.27 [159.26]	7.40 [187.96]	8.25 [209.55]	2.00 [50.80]	.28 x .88 [7.12 x 22.36]	4	N2	28.0 [12.6]	45.0 [20.3]
80	RC0080P40	0.40	193	9.00 [228.60]	7.83 [198.89]	7.40 [187.96]	8.25 [209.55]	2.00 [50.80]	.28 x .88 [7.12 x 22.36]	4	N2	38.0 [17.1]	55.0 [24.8]
110	RC0110P30	0.30	423	14.00 [355.60]	8.70 [220.98]	11.62 [295.15]	3.6/4.8 [91.44/121.92]	4.20 [106.68]	.44 X 1.25 [11.18 x 31.75]	5	NH5	55.0 [24.8]	95.0 [42.8]
130	RC0130P20	0.20	415	14.00 [355.60]	8.20 [208.28]	11.62 [295.15]	3.6/4.8 [91.44/121.92]	3.73 [94.75]	.44 X 1.25 [11.18 x 31.75]	5	NH5	44.0 [19.8]	88.0 [39.6]
160	RC0160P15	0.15	429	14.00 [355.60]	8.70 [220.98]	11.62 [295.15]	3.6/4.8 [91.44/121.92]	4.23 [107.45]	.44 X 1.25 [11.18 x 31.75]	5	NH5	49.0 [22.1]	89.0 [40.1]
200	RC0200P11	0.11	414	14.00 [355.60]	9.23 [234.45]	11.62 [295.15]	3.6/4.8 [91.44/121.92]	4.23 [107.45]	.44 X 1.25 [11.18 x 31.75]	5	NH6	55.0 [24.8]	115.0 [52.0]
250	RC0250U90	0.090	431	14.00 [355.60]	9.73 [247.15]	11.62 [295.15]	3.6/4.8 [91.44/121.92]	4.70 [119.38]	.44 X 1.25 [11.18 x 31.75]	5	NH6	68.0 [30.6]	128.0 [58.0]
320	RC0320U75	0.075	484	14.40 [365.76]	9.50 [241.30]	11.43 [290.33]	4.80 [121.92]	5.94 [150.88]	.44 X 1.00 [11.18 x 25.4]	6	NH6	90.0 [40.5]	150.0 [68.0]
400	RC0400U61	0.061	477	14.40 [365.76]	11.50 [292.10]	11.43 [290.33]	4.80 [121.92]	6.44 [163.58]	.44 X 1.00 [11.18 x 25.4]	6	NH6	118.0 [53.0]	178.0 [80.0]
500	RC0500U50	0.05	496	14.40 [365.76]	11.50 [292.10]	11.43 [290.33]	4.80 [121.92]	6.44 [163.58]	.44 X 1.00 [11.18 x 25.4]	6	NH3	154.0 [69.0]	231.0 [104.0]
600	RC0600U40	0.040	523	14.40 [365.76]	12.00 [304.80]	11.43 [290.33]	4.80 [121.92]	6.94 [176.28]	.44 X 1.00 [11.18 x 25.4]	6	NH4	180.0 [81.0]	287.0 [129.0]

Note: Please refer to pages 6 and 7 for enclosure dimensional specifications

# CORE AND COIL REFERENCE DRAWINGS

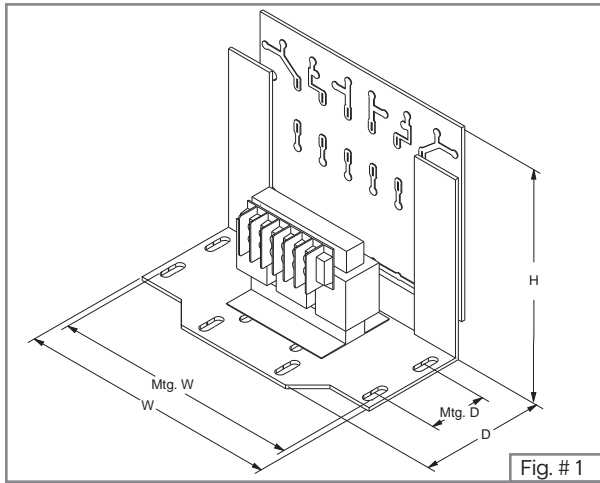

Fig. # 1

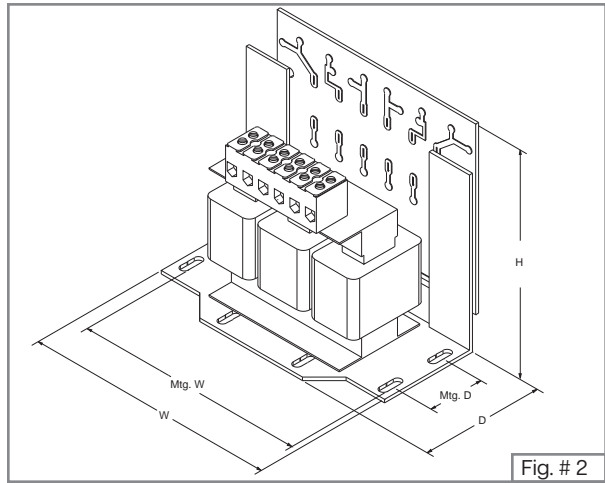

Fig. # 2

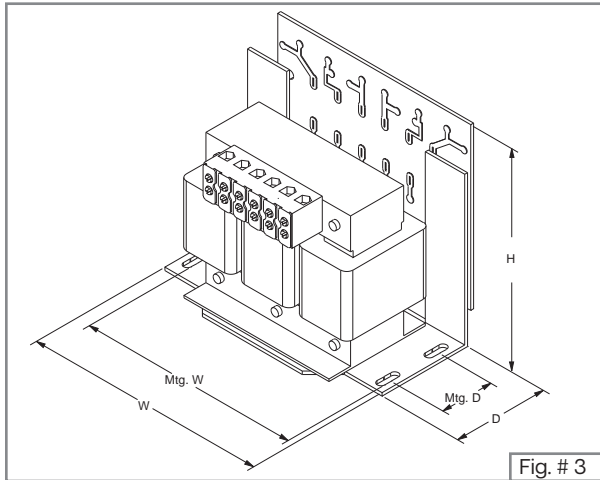

Fig. # 3

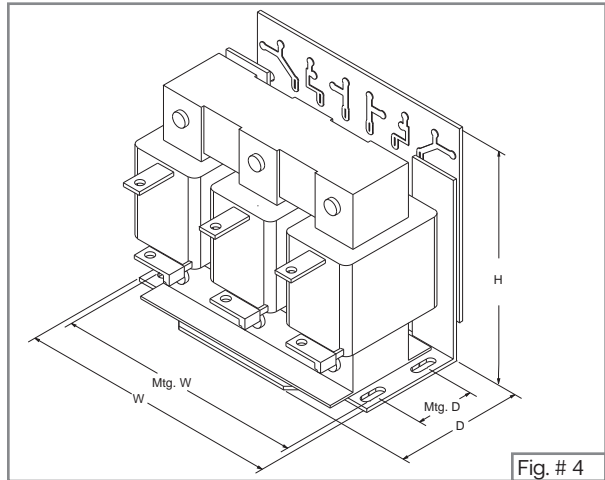

Fig. # 4

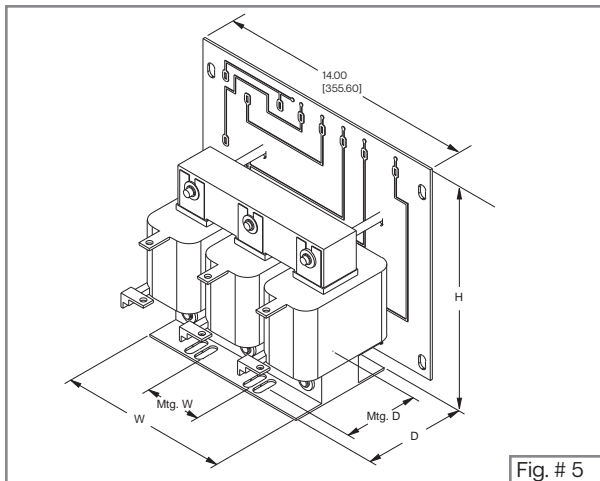

Fig. # 5

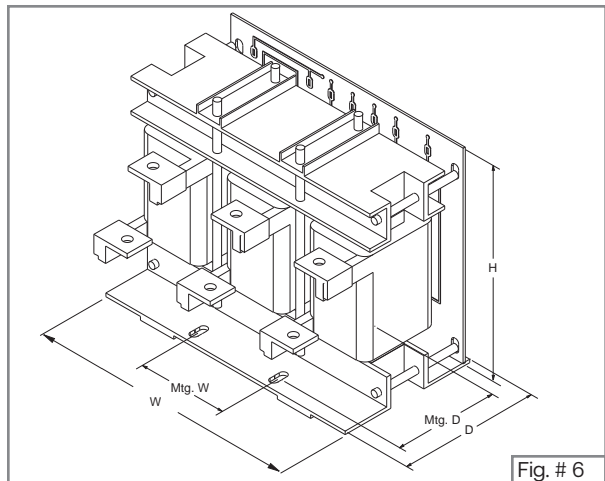
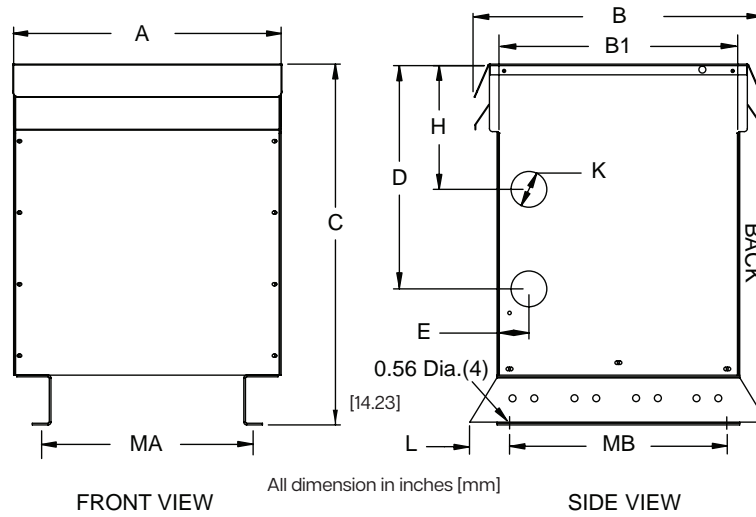

Fig. # 6

## Type 3R Enclosure Dimensional Drawings

### 'NH' SERIES ENCLOSURES



Case Style	Dimensions in Inches [mm]										
	A	B	B <sup>1</sup>	C	D	E	H	K <sup>1</sup>	L	MA	MB
NH3	26.00 [660.40]	25.00 [635.00]	24.00 [609.60]	38.00 [965.20]	24.00 [609.60]	2.50 [63.50]	14.00 [355.60]	2.00 x 3.00 [50.8 x 76.2]	2.50 [63.50]	21.50 [546.10]	19.00 [482.60]
NH4	32.00 [812.80]	29.50 [749.30]	28.50 [723.90]	41.00 [1041.40]	24.00 [609.60]	2.50 [63.50]	12.00 [304.80]	2.00 x 3.00 [50.8 x 76.2]	2.50 [63.50]	23.50 [596.90]	23.50 [596.90]

Note: Mounting hole dimension is 0.56 [14.23] diameter.

<sup>1</sup> Knockout (K) sizes are actual diameters of knockout, not conduit sizes. Refer to table on page 7 for conduit sizes.

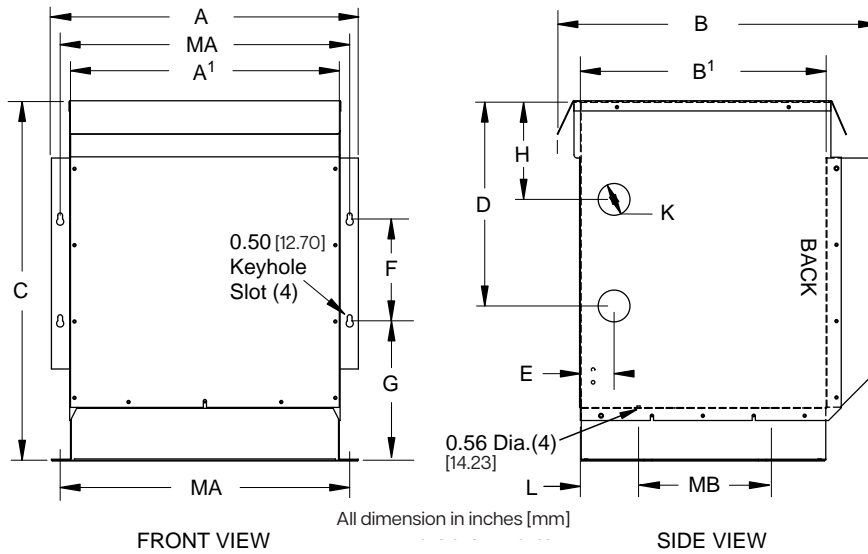

Case Style	Dimensions in Inches [mm]													
	A	A <sup>1</sup>	B	B <sup>1</sup>	C	D	E	F	G	H	K <sup>1</sup>	L	MA	MB
NH5	19.40 [492.76]	16.75 [425.45]	20.20 [513.08]	15.00 [381.00]	21.50 [546.10]	12.00 [304.80]	2.00 [50.80]	7.00 [177.80]	7.81 [198.38]	6.00 [152.40]	1.38 x 1.75 [35.06 x 44.45]	2.80 [71.12]	18.00 [457.20]	9.00 [228.60]
NH6	23.90 [607.06]	21.50 [546.10]	25.00 [635.00]	19.50 [495.30]	28.75 [730.25]	17.00 [431.80]	2.00 [50.80]	8.00 [203.20]	10.29 [261.37]	8.50 [215.90]	1.38 x 2.50 [35.06 x 63.5]	5.20 [132.08]	22.75 [577.85]	9.00 [228.60]

Note: Mounting hole dimension is 0.56 [14.23] diameter.

<sup>1</sup> Knockout (K) sizes are actual diameters of knockout, not conduit sizes. Refer to table on page 7 for conduit sizes.

# Type 2 Enclosure Dimensional Drawings

'N1' SERIES ENCLOSURE

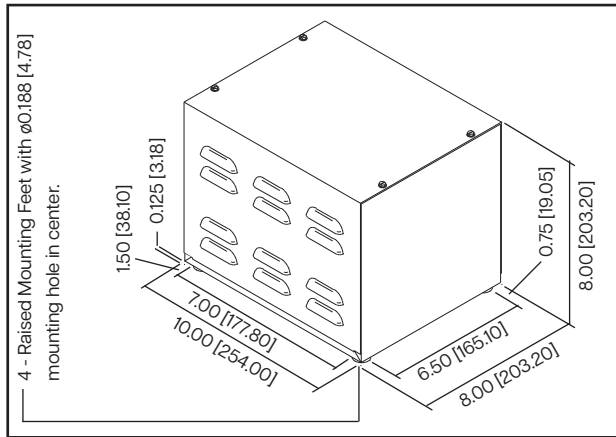

All dimension in inches [mm]

'N2' SERIES ENCLOSURE

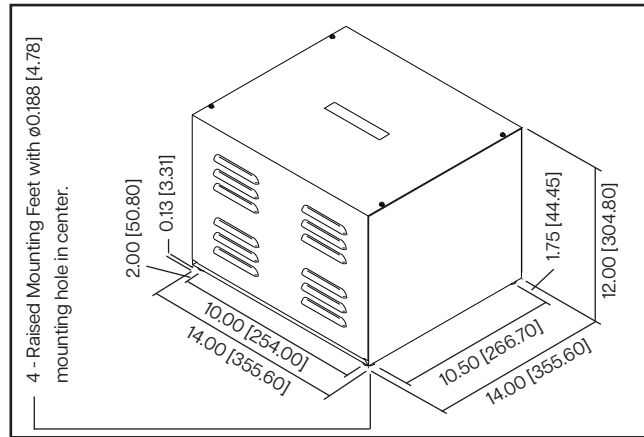

All dimension in inches [mm]

## Conduit Size vs. Actual Knockout Size Reference Table

Standard Conduit Size	Actual Knockout Diameter
0.50 [12.70]	0.88 [22.23]
0.75 [19.05]	1.13 [28.58]
1.00 [25.40]	1.38 [34.93]
1.25 [31.75]	1.75 [44.45]
1.50 [38.10]	2.00 [50.80]
2.00 [50.80]	2.50 [63.50]
2.50 [63.50]	3.00 [76.20]
3.00 [76.20]	3.63 [92.08]
3.50 [88.90]	4.13 [104.78]

Please note the above table is not applicable for Stainless Steel enclosures.  
All dimension in inches [mm]





## CANADA

### Hammond Power Solutions

595 Southgate Drive  
Guelph, Ontario N1G 3W6  
Tel: (519) 822-2441 | Fax: (519) 822-9701  
Toll Free: 1-888-798-8882

[sales@hammondpowersolutions.com](mailto:sales@hammondpowersolutions.com)



## UNITED STATES

### Hammond Power Solutions

1100 Lake Street  
Baraboo, Wisconsin 53913-2866  
Tel: (608) 356-3921 | Fax: (608) 355-7623  
Toll Free: 1-866-705-4684

[sales@hammondpowersolutions.com](mailto:sales@hammondpowersolutions.com)



## MEXICO

### Hammond Power Solutions Latin America S.

Av. No. 800,  
Parque Industrial Guadalupe  
Guadalupe, NL, Mexico, C.P. 67190.  
Tel: (819) 690-8000

[sales@hammondpowersolutions.com](mailto:sales@hammondpowersolutions.com)



## ASIA

### Hammond Power Solutions Pvt. Ltd.

Plot No 6A, Phase -1, IDA,  
Pashamylaram, Patancheru (M)  
Sangareddy, 502 307, India  
Tel: +91-994-995-0009

[marketing-india@hammondpowersolutions.com](mailto:marketing-india@hammondpowersolutions.com)

## EMEA (SALES OFFICE)

### Hammond Power Solutions SpA

Tel: +49 (152) 08800468

[sales-emea@hammondpowersolutions.com](mailto:sales-emea@hammondpowersolutions.com)



[hammondpowersolutions.com](http://hammondpowersolutions.com)



DOENRSEL17  
Feb 2023