

ENERGY EFFICIENT DISTRIBUTION TRANSFORMERS



Energy Efficient Distribution Transformers

TABLE OF CONTENTS

US & Canada Energy Efficiency Regulations	03	Typical Performance Data	26
HPS DOE & NRCAN Compliant Products	03	Typical Impedance & Inrush Current Range	28
Features & Benefits	04	Termination Details	29
Specifications & Accessories	06	Enclosure Dimensional Drawings	30
Part Number Guide	07	Enclosure Mounting Kits	32
Support & Resources	07	Enclosure Wall & Ceiling Mounting Dimensions	33
Selection Tables - General Purpose Distribution Transformers	08	Anti-Vibration Pads & Vibration Isolator Kits	34
Selection Tables - K-Rated Distribution Transformers	18	Enclosure Spare Parts	35
Selection Tables - Harmonic Mitigating Transformers	24	Electrical Schematics & Connection Drawings	36

This catalog contains product information for DOE 2016 & NRCAN 2019 compliant energy efficient low voltage distribution transformers. For product information pertaining to lower efficiency distribution transformers, please refer to the HTP-17 catalog.



Improved Efficiency For a Greener Tomorrow

Transformers have been and remain an essential part of our electrical infrastructure. Everywhere we look there is a transformer supplying power to industrial, commercial, or residential applications.

Improving the energy efficiency of new transformers is a primary goal for both the U.S. Department of Energy (DOE) and Natural Resources Canada (NRCAN). New and more stringent energy efficiency regulations are in effect in the US since January 1st, 2016; regulations for Canada are in effect since April 30th, 2019.

HPS proudly supports the new legislations and the environmental benefits resulting from using higher efficiency transformers.

Environmental Benefits of Increased Energy Efficiency

Upgrading one 75kVA transformer to a new DOE 2016/NRCAN 2019 design translates to one of the following environmental benefits per year*



2.9
additional
acres of
forest in
one year



1.3
tons of
waste sent
to the
landfill



403
gallons
of gasoline
consumed



3,486
pounds
of coal
burned

*Estimated savings based on a pre TP-1 upgrade and a mix of energy sources. Calculations derived from www.epa.gov/cleanenergy/energy-resources/calculator.html

US & Canada Energy Efficiency Regulations

As of January 1st 2016, the US Department of Energy (DOE) introduced new, higher energy efficiency levels for dry-type transformers installed in the USA.

As of April 30th, 2019 Natural Resources Canada (NRCAN) aligned the dry-type transformer energy efficiency requirements to those prescribed by DOE 2016. Ontario was the first province to adopt the new NRCAN efficiency levels effective January 1st 2018.

Low Voltage Dry-Type Distribution:

- › 1PH 15-333kVA, ≤ 10kV BIL
- › 3PH 15-1000kVA, ≤ 10kV BIL

**Non-Ventilated and encapsulated transformers are exempt from these efficiency requirements.*

DOE 2016/NRCAN 2019 Compliant HPS Distribution Transformers

The DOE 2016/NRCAN 2019 product lines have been redesigned based on extensive customer input using industry leading technologies and materials to meet your most demanding applications.

HPS has three lines of low voltage DOE 2016/NRCAN 2019 compliant energy efficient distribution transformers:

General Purpose Distribution Transformers:

Rated for 600 volts and below and are generally used to power appliances, lighting, heating, motorized machine and power loads from the electrical distribution system.

K-Rated Distribution Transformers:

Specifically designed to handle the harmonics generated by non-linear loads such as computer and telecommunication equipment, drives and other power electronics.

Harmonic Mitigating Transformers:

Superior to k-rated transformers, they are designed to treat the harmonics generated by computer equipment and other non-linear, power electronic loads. HMT's combine zero sequence flux cancellation with phase shifting to mitigate 3rd, 5th, 7th, 9th, 15th, 17th, and 19th harmonics within their secondary windings.



New Energy Efficiency Levels

The new energy efficiency levels for low voltage dry-type distribution transformers:

Single Phase		Three Phase	
kVA	Efficiency (%)	kVA	Efficiency (%)
15	97.70	15	97.89
25	98.00	30	98.23
37.5	98.20	45	98.40
50	98.30	75	98.60
75	98.50	112.5	98.74
100	98.60	150	98.83
167	98.70	225	98.94
250	98.80	300	99.02
333	98.90	500	99.14
		750	99.23
		1000	99.28

Note: All efficiency values are at 35% of nominal load.

Energy Efficient Distribution Transformers

Benefits

- HPS energy efficient distribution transformer product lines meet the latest energy efficiency standards outlined by DOE and NRCAN offering significant energy savings to our customers and positive societal/environmental benefits.
- Standard Type 3R enclosure suitable for indoor or outdoor applications.
- **For our customers, higher efficiency translates into:**
 - › Increased profitability due to lower operating costs
 - › Decreased cost of ownership over the lifetime of the transformer
 - › Less air conditioning cost due to lower heat emissions
- Expanded catalog product offer - up to 1500kVA*
- Standard 10kV BIL rating provides increased reliability and protection against critical equipment failure (including voltage spikes and other line transients).
- Standard integral floor and wall mounting brackets up to 50kVA allow for faster installation.
- All units utilize a uniform 220°C insulation system with a 80°C, 115°C, or 150°C temperature rise.
- Industry leading design solutions, technology and materials continue the legacy of quality and reliability in all HPS products.

* Units >1000kVA are exempt from the efficiency standards



Features

Core & Coil Construction:

- Manufactured from quality non-aging, cold rolled, silicon steel laminations using state-of-the-art equipment
- Cores are precision cut to close tolerances which eliminates burrs and improves performance
- Core is coated to prevent the ingress of moisture
- Precision wound with copper or aluminum conductors that are electrically balanced to minimize axial forces during short-circuit conditions
- Robust interface between core & coils for better short circuit performance

Conductor material: Copper or Aluminum

Temperature rise: 150°C typical (low rise options avail.)

Insulation system: 220°C



Standard type 3R enclosure on all low voltage HPS transformers



Integrated wall mounting brackets for added convenience at no extra cost

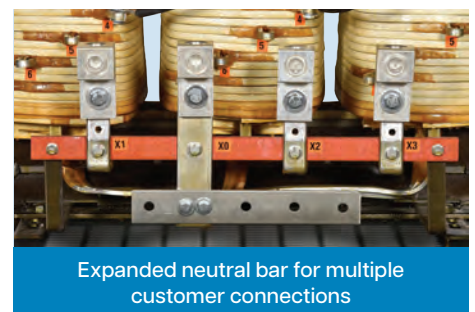

Expanded neutral bar for multiple customer connections

Installation made fast & easy!

Tired of spending extra money on labor and material to install optional transformer features? Purchasing an HPS distribution transformer will save you all these additional costs. HPS distribution transformers have these optional features pre-installed as part of our standard product line.

Testing

All HPS transformers are tested at HPS prior to shipment. They must meet very stringent quality criteria prior to release.

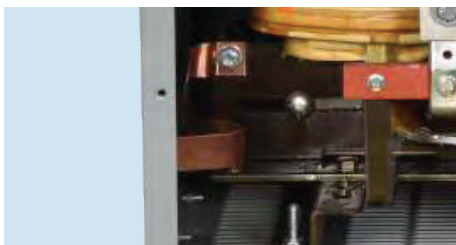
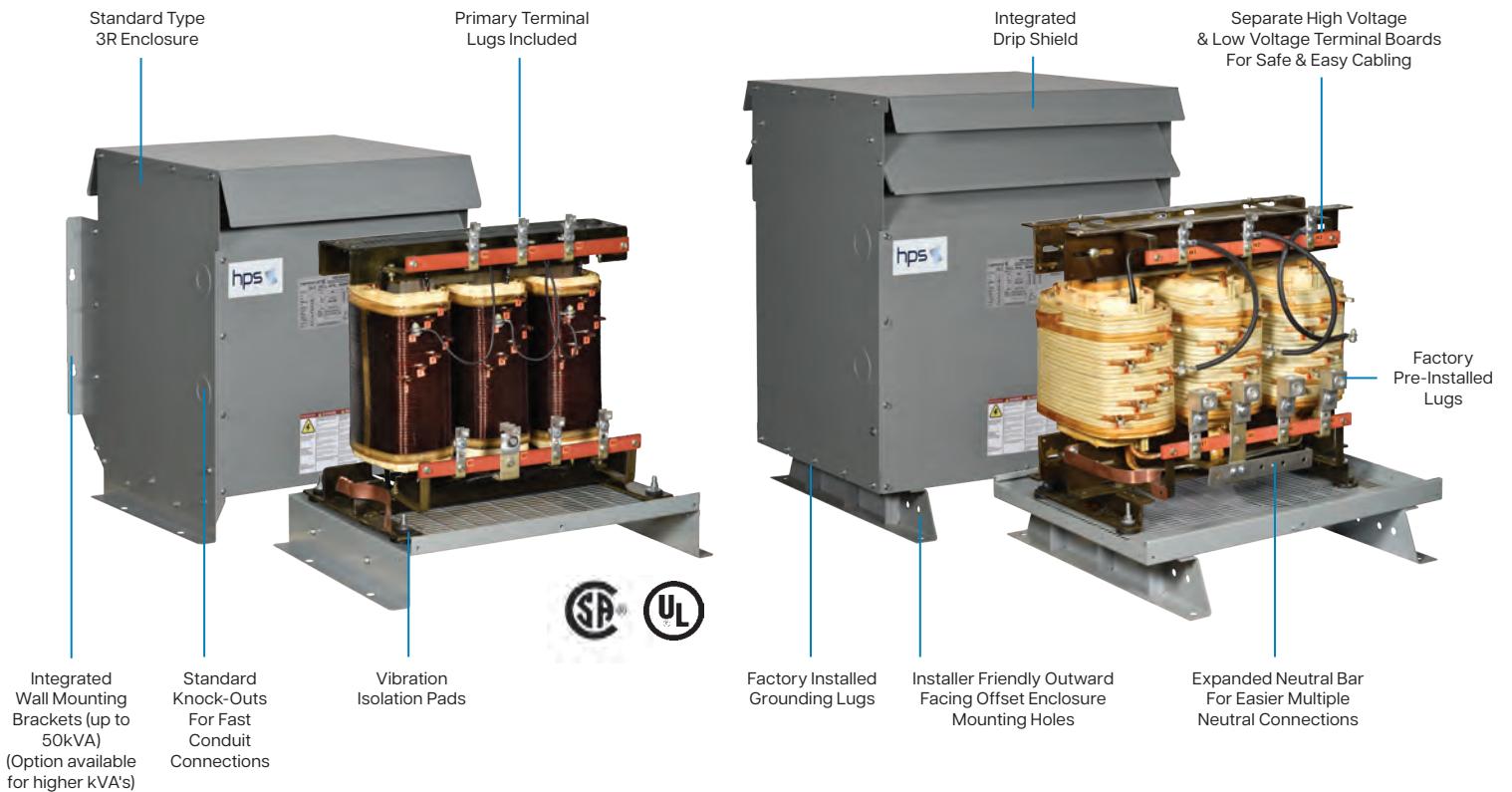

Factory installed main grounding lugs



Bottom cable entry area (where applicable)



Offset outward facing floor installation holes for easy power tool access

Specifications & Accessories - Copper or Aluminum



15 to 45 kVA



75 to 150 kVA



225 to 1000 kVA

Standard Specifications

kVA:	15-1500kVA
UL Listed:	File: E112313
CSA Certified:	File: LR3902
Frequency:	60 Hz (optional 50/60 Hz available)
Insulation System:	220°C (150°C rise) (optional 115°C & 80°C rise available)
BIL Rating:	10 kV
Enclosure Type:	Heavy duty ventilated Type 3R standard [optional Type 4, 4X (stainless steel) & 12 - outside of DOE/NRCan scope]
Enclosure Finish:	ANSI 61 Grey, UL50
Neutral:	Neutral terminal for field connection (on applicable units)
Standard Primary Taps:	Refer to wiring diagrams for details
Termination:	Front accessible separate high and low voltage terminals; connectors suitable for aluminum and copper are provided for easy cable installation (exceptions apply).
Conduit Entry:	Side knock-outs standard on all units; Bottom entry provision (exceptions apply).
Impedance:	Typically 1.8% to 7.5%
Mounting:	Floor or wall/ceiling mounting available. Refer to selection tables for details.
Seismic:	Seismically qualified according to the International Building Code (IBC) 2018, and the American Society of Civil Engineers ASCE 7-16 specifications, with the following design parameters: Spectral acceleration: SDS ≤2.0 g Importance factor: I _p = 1.5 Attachment/Height ratio: z/h = 1.0 (up to and including DH4 enclosure). Attachment/Height ratio: z/h = 0 (for all other enclosures). O.S.H.P.D (optional). Please contact HPS for more information on seismic compliances.
Sound Level:	Meets NEMA ST-20 standards (optional low noise units available)
Warranty:	10 years

HPS Smart Transformers

HPS also offers a line of low voltage Smart Transformers with integrated power monitoring for enhanced energy management and real-time performance insights. These solutions provide critical data for remote monitoring and predictive maintenance, helping maximize uptime and asset management. For more information on HPS Smart Transformers, visit the HPS website.

Optional Accessories:

- Thermal sensing & indication
- Thermocouples
- Thermometers (analog/digital)
- Thermostat alarm / trip (N.O. /N.C. contacts)
- Electrostatic shielding
- Rated to handle current harmonics [K4] [K9] [K13]
- Strip heater (space heater to prevent condensation)
- Surge protection devices
- Rodent Kit
- Type 3R or 4X available in stainless steel
- Type 3R enhanced with baffling for horizontal blowing rain and snow
- Optional infrared windows
- Grounding Kit

HPS Energy Efficient Distribution Transformers Part Number Guide

Example

Family Type	Generation	Phase	kVA				Pri. Volt.	Sec. Volt.	K Rating	Winding Material/ Electrostatic Shield	Temp. Rise & Insul. Class	Enclosure	Sound Level	Special Duty
SG	3	A	0	0	4	5	K	B	0	K	F	K	0	M

Family Type	kVA	K Rating	Sound Level
SG - General Purpose Distribution SK - K-Rated Distribution SH - Harmonic Mitigating	kVA Rating	0 = None* 4 = K4 9 = K9 3 = K13 2 = K20 (max. 300 kVA)	0 = Standard* 3 = -3 dB 5 = -5 dB 8 = -8 dB ⁴
Generation 3 - current designs	Primary Voltage 1PH: B - 208 D - 240 F - 277 3PH: 208D, 208Y/120 240D	Winding Material/Electrostatic Shield A - Aluminum* S - AL + Shield C - Copper K - CU + Shield	Special Duty None = Default D = Land Drilling M = Marine Duty W = IR Window S = Solar Duty ⁵
Phase (Pri-Sec)¹ A - 3PH Delta-Wye-N B - 3PH Wye-N-Delta C - 3PH Delta-Delta/CT ² D - 3PH Delta-Delta Y - 3PH Wye-N-Wye-N T - 3PH Delta Zig Zag 0° PH Shift U - 3PH Wye Zig Zag -30°PH Shift L - 1PH Single-Dual N - 1PH Dual-Dual M - 1PH Multiple-Dual	Secondary Voltage 1PH: B - 208 D - 240 3PH: 208D, 208Y/120 240D, 240D/120CT or 240Y/139 E - 120/240 K - 480 M - P - 600 V - Y - 480D or 480Y/277 440Y/254 600D or 600Y/347 220Y/127 380Y/220V w taps at 400Y, 416Y and 430Y	Temperature Rise at standard 220°C Insulation Class B - 80°C F - 115°C G - 130°C H - 150°C*	
		Enclosure C - Type 3R* D - Type 3RE E - Type 3RX F - Type 4 ³ G - Type 4X (304SS) ³ H - Type 4X (316SS) ³ K - Type 12 ³ X - None (Core & Coil)	

¹ Standard configurations winding vector per UL 1560

² Available standard only with 240D/120CT secondaries

³ Outside of DOE/NRCAn scope - non-energy efficient product provided unless otherwise specified

⁴ 8dB is available only for 75kVA and above

⁵ Solar duty option available with three phase only

Support & Resources

No other transformer company can offer our service and quality in a full range of products.



Transformer Efficiency Calculator

The HPS Efficiency Calculator allows you to determine how much money and energy you can save by switching to a HPS distribution transformer. Visit the "Online Tools" area of the HPS website.



Current Calculator

Calculate the Amps, Volts, or kVA of a transformer. Visit the "Online Tools" area of the HPS website.



Fast On-Site Response

On-site technicians are available to assist with any technical problems or issues that cannot be resolved over the phone.



Extensive Inventory

We carry a complete inventory of Distribution Transformers throughout North America to quickly meet your needs.



Live Telephone Technical Support

Our inside sales team is available to quickly answer your questions. They are technically trained and able to answer most questions right over the phone.



Easy-To-Access Installation Manuals

All transformer installation manuals are conveniently located on our website so you can access them anywhere, anytime.

SELECTION TABLES

GENERAL PURPOSE DISTRIBUTION TRANSFORMERS



Aluminum Wound, Single Phase

208 PRIMARY VOLTS			120/240 SECONDARY VOLTS			60 HZ		
kVA	Catalog Number	Case Style	Approx. Dimensions - Inches [mm]			Approx. Weight Lbs [kg]	Mtg Type W - Wall F - Floor	Wiring Diagram
			Width	Depth	Height			
15	SG3L0015BE	DH1-1	22.30 [566]	23.80 [604]	26.70 [678]	160 [72]	F or W/C*	SCD 6
25	SG3L0025BE	DH1-1	22.30 [566]	23.80 [604]	26.70 [678]	210 [95]	F or W/C*	SCD 6
37.5	SG3L0037BE	DH1-1	22.30 [566]	23.80 [604]	26.70 [678]	270 [122]	F or W/C*	SCD 6
50	SG3L0050BE	DH2	25.75 [654]	23.75 [603]	28.75 [730]	330 [150]	F or W/C*	SCD 6
75	SG3L0075BE	DH3	28.25 [717]	27.00 [686]	36.00 [914]	480 [218]	F (Opt W/C)	SCD 6
100	SG3L0100BE	DH3	28.25 [717]	27.00 [686]	36.00 [914]	540 [245]	F (Opt W/C)	SCD 6
150	SG3L0150BE	DH4	31.50 [800]	29.50 [749]	44.50 [1130]	790 [358]	F	SCD 68

240 X 480 PRIMARY VOLTS			120/240 SECONDARY VOLTS			60 HZ		
kVA	Catalog Number	Case Style	Approx. Dimensions - Inches [mm]			Approx. Weight Lbs [kg]	Mtg Type W - Wall F - Floor	Wiring Diagram
			Width	Depth	Height			
15	SG3N0015LE	DH1-1	22.30 [566]	23.80 [604]	26.70 [678]	160 [72]	F or W/C*	SCD 17
25	SG3N0025LE	DH1-1	22.30 [566]	23.80 [604]	26.70 [678]	210 [95]	F or W/C*	SCD 17
37.5	SG3N0037LE	DH1-1	22.30 [566]	23.80 [604]	26.70 [678]	270 [122]	F or W/C*	SCD 17
50	SG3N0050LE	DH2	25.75 [654]	23.75 [603]	28.75 [730]	330 [150]	F or W/C*	SCD 17
75	SG3N0075LE	DH3	28.25 [717]	27.00 [686]	36.00 [914]	480 [218]	F (Opt W/C)	SCD 17
100	SG3N0100LE	DH3	28.25 [717]	27.00 [686]	36.00 [914]	540 [245]	F (Opt W/C)	SCD 17
150	Available with 480V or 240V single primaries only. Please contact your HPS Sales Representative.							
167	Available with 480V or 240V single primaries only. Please contact your HPS Sales Representative.							

277 PRIMARY VOLTS			120/240 SECONDARY VOLTS			60 HZ		
kVA	Catalog Number	Case Style	Approx. Dimensions - Inches [mm]			Approx. Weight Lbs [kg]	Mtg Type W - Wall F - Floor	Wiring Diagram
			Width	Depth	Height			
15	SG3L0015FE	DH1-1	22.30 [566]	23.80 [604]	26.70 [678]	160 [72]	F or W/C*	SCD 6
25	SG3L0025FE	DH1-1	22.30 [566]	23.80 [604]	26.70 [678]	210 [95]	F or W/C*	SCD 6
37.5	SG3L0037FE	DH1-1	22.30 [566]	23.80 [604]	26.70 [678]	270 [122]	F or W/C*	SCD 6
50	SG3L0050FE	DH2	25.75 [654]	23.75 [603]	28.75 [730]	330 [150]	F or W/C*	SCD 6
75	SG3L0075FE	DH3	28.25 [717]	27.00 [686]	36.00 [914]	480 [218]	F (Opt W/C)	SCD 6
100	SG3L0100FE	DH3	28.25 [717]	27.00 [686]	36.00 [914]	540 [245]	F (Opt W/C)	SCD 6
150	SG3L0150FE	DH4	31.50 [800]	29.50 [749]	44.50 [1130]	790 [358]	F	SCD 68
167	SG3L0167FE	DH4	31.50 [800]	29.50 [749]	44.50 [1130]	880 [399]	F	SCD 68

416 PRIMARY VOLTS			120/240 SECONDARY VOLTS			60 HZ		
kVA	Catalog Number	Case Style	Approx. Dimensions - Inches [mm]			Approx. Weight Lbs [kg]	Mtg Type W - Wall F - Floor	Wiring Diagram
			Width	Depth	Height			
15	SG3L0015HE	DH1-1	22.30 [566]	23.80 [604]	26.70 [678]	160 [72]	F or W/C*	SCD 6
25	SG3L0025HE	DH1-1	22.30 [566]	23.80 [604]	26.70 [678]	210 [95]	F or W/C*	SCD 6
37.5	SG3L0037HE	DH1-1	22.30 [566]	23.80 [604]	26.70 [678]	270 [122]	F or W/C*	SCD 6
50	SG3L0050HE	DH2	25.75 [654]	23.75 [603]	28.75 [730]	330 [150]	F or W/C*	SCD 6
75	SG3L0075HE	DH3	28.25 [717]	27.00 [686]	36.00 [914]	480 [218]	F (Opt W/C)	SCD 6
100	SG3L0100HE	DH3	28.25 [717]	27.00 [686]	36.00 [914]	540 [245]	F (Opt W/C)	SCD 6
150	SG3L0150HE	DH4	31.50 [800]	29.50 [749]	44.50 [1130]	790 [358]	F	SCD 39
167	SG3L0167HE	DH4	31.50 [800]	29.50 [749]	44.50 [1130]	880 [399]	F	SCD 39

*W/C: Built-in Wall Ceiling Mounting Opt W/C: Wall Ceiling Mounting Kit "DW3" Available

SELECTION TABLES

GENERAL PURPOSE DISTRIBUTION TRANSFORMERS



Aluminum Wound, Single Phase

600 PRIMARY VOLTS			120/240 SECONDARY VOLTS			60 HZ		
kVA	Catalog Number	Case Style	Approx. Dimensions - Inches [mm]			Approx. Weight Lbs [kg]	Mtg Type W - Wall F - Floor	Wiring Diagram
			Width	Depth	Height			
15	SG3L0015PE	DH1-1	22.30 [566]	23.80 [604]	26.70 [678]	160 [72]	F or W/C*	SCD 6
25	SG3L0025PE	DH1-1	22.30 [566]	23.80 [604]	26.70 [678]	210 [95]	F or W/C*	SCD 6
37.5	SG3L0037PE	DH1-1	22.30 [566]	23.80 [604]	26.70 [678]	270 [122]	F or W/C*	SCD 6
50	SG3L0050PE	DH2	25.75 [654]	23.75 [603]	28.75 [730]	330 [150]	F or W/C*	SCD 6
75	SG3L0075PE	DH3	28.25 [717]	27.00 [686]	36.00 [914]	480 [218]	F (Opt W/C)	SCD 6
100	SG3L0100PE	DH3	28.25 [717]	27.00 [686]	36.00 [914]	540 [245]	F (Opt W/C)	SCD 6
150	SG3L0150PE	DH4	31.50 [800]	29.50 [749]	44.50 [1130]	790 [358]	F	SCD 39
167	SG3L0167PE	DH4	31.50 [800]	29.50 [749]	44.50 [1130]	880 [399]	F	SCD 39

SINGLE PHASE, EXPORT MODEL

190/200/208/220 X 380/400/416/440 PRIMARY VOLTS			120/240 SECONDARY VOLTS			50/60 HZ**		
kVA	Catalog Number	Case Style	Approx. Dimensions - Inches [mm]			Approx. Weight Lbs [kg]	Mtg Type W - Wall F - Floor	Wiring Diagram
			Width	Depth	Height			
15	SG3M0015XE	DH1-1	22.30 [566]	23.80 [604]	26.70 [678]	160 [72]	F or W/C*	SCD 30
25	SG3M0025XE	DH1-1	22.30 [566]	23.80 [604]	26.70 [678]	210 [95]	F or W/C*	SCD 30
37.5	SG3M0037XE	DH1-1	22.30 [566]	23.80 [604]	26.70 [678]	270 [122]	F or W/C*	SCD 30
50	SG3M0050XE	DH2	25.75 [654]	23.75 [603]	28.75 [730]	330 [150]	F or W/C*	SCD 30
75	SG3M0075XE	DH3	28.25 [717]	27.00 [686]	36.00 [914]	480 [218]	F (Opt W/C)	SCD 30
100	SG3M0100XE	DH3	28.25 [717]	27.00 [686]	36.00 [914]	540 [245]	F (Opt W/C)	SCD 30
150	SG3M0150XE		Please contact your HPS Sales Representative					
167	SG3M0167XE		Please contact your HPS Sales Representative					

*W/C: Built-in Wall Ceiling Mounting Opt W/C: Wall Ceiling Mounting Kit "DW3" Available

**Note: Meets DOE 2016/NRCAN 2019 at 60 Hz.

Copper Wound, Single Phase

208 PRIMARY VOLTS			120/240 SECONDARY VOLTS			60 HZ		
kVA	Catalog Number	Case Style	Approx. Dimensions - Inches [mm]			Approx. Weight Lbs [kg]	Mtg Type W - Wall F - Floor	Wiring Diagram
			Width	Depth	Height			
15	SG3L0015BEOC	DH1-1	22.30 [566]	23.80 [604]	26.70 [678]	175 [79]	F or W/C*	SCD 6
25	SG3L0025BEOC	DH1-1	22.30 [566]	23.80 [604]	26.70 [678]	230 [104]	F or W/C*	SCD 6
37.5	SG3L0037BEOC	DH1-1	22.30 [566]	23.80 [604]	26.70 [678]	300 [136]	F or W/C*	SCD 6
50	SG3L0050BEOC	DH2	25.75 [654]	23.75 [603]	28.75 [730]	350 [159]	F or W/C*	SCD 6
75	SG3L0075BEOC	DH3	28.25 [717]	27.00 [686]	36.00 [914]	520 [236]	F (Opt W/C)	SCD 6
100	SG3L0100BEOC	DH3	28.25 [717]	27.00 [686]	36.00 [914]	630 [286]	F (Opt W/C)	SCD 6
150	SG3L0150BEOC	DH4	31.50 [800]	29.50 [749]	44.50 [1130]	920 [417]	F	SCD 68
167	SG3L0167BEOC	DH4	31.50 [800]	29.50 [749]	44.50 [1130]	980 [444]	F	SCD 68

*W/C: Built-in Wall Ceiling Mounting Opt W/C: Wall Ceiling Mounting Kit "DW3" Available

SELECTION TABLES

GENERAL PURPOSE DISTRIBUTION TRANSFORMERS



Copper Wound, Single Phase

240 X 480 PRIMARY VOLTS

120/240 SECONDARY VOLTS

60 HZ

kVA	Catalog Number	Case Style	Approx. Dimensions - Inches [mm]			Approx. Weight Lbs [kg]	Mtg Type W - Wall F - Floor	Wiring Diagram
			Width	Depth	Height			
15	SG3N0015LEOC	DH1-1	22.30 [566]	23.80 [604]	26.70 [678]	175 [79]	F or W/C*	SCD 17
25	SG3N0025LEOC	DH1-1	22.30 [566]	23.80 [604]	26.70 [678]	230 [104]	F or W/C*	SCD 17
37.5	SG3N0037LEOC	DH1-1	22.30 [566]	23.80 [604]	26.70 [678]	300 [136]	F or W/C*	SCD 17
50	SG3N0050LEOC	DH2	25.75 [654]	23.75 [603]	28.75 [730]	350 [159]	F or W/C*	SCD 17
75	SG3N0075LEOC	DH3	28.25 [717]	27.00 [686]	36.00 [914]	520 [236]	F (Opt W/C)	SCD 17
100	SG3N0100LEOC	DH3	28.25 [717]	27.00 [686]	36.00 [914]	630 [286]	F (Opt W/C)	SCD 17
150	Available with 480V or 240V single primaries only. Please contact your HPS Sales Representative.							
167	Available with 480V or 240V single primaries only. Please contact your HPS Sales Representative.							

277 PRIMARY VOLTS

120/240 SECONDARY VOLTS

60 HZ

kVA	Catalog Number	Case Style	Approx. Dimensions - Inches [mm]			Approx. Weight Lbs [kg]	Mtg Type W - Wall F - Floor	Wiring Diagram
			Width	Depth	Height			
15	SG3L0015FE0C	DH1-1	22.30 [566]	23.80 [604]	26.70 [678]	175 [79]	F or W/C*	SCD 6
25	SG3L0025FE0C	DH1-1	22.30 [566]	23.80 [604]	26.70 [678]	230 [104]	F or W/C*	SCD 6
37.5	SG3L0037FE0C	DH1-1	22.30 [566]	23.80 [604]	26.70 [678]	300 [136]	F or W/C*	SCD 6
50	SG3L0050FE0C	DH2	25.75 [654]	23.75 [603]	28.75 [730]	350 [159]	F or W/C*	SCD 6
75	SG3L0075FE0C	DH3	28.25 [717]	27.00 [686]	36.00 [914]	520 [236]	F (Opt W/C)	SCD 6
100	SG3L0100FE0C	DH3	28.25 [717]	27.00 [686]	36.00 [914]	630 [286]	F (Opt W/C)	SCD 6
150	SG3L0150FE0C	DH4	31.50 [800]	29.50 [749]	44.50 [1130]	920 [417]	F	SCD 68
167	SG3L0167FE0C	DH4	31.50 [800]	29.50 [749]	44.50 [1130]	980 [444]	F	SCD 68

416 PRIMARY VOLTS

120/240 SECONDARY VOLTS

60 HZ

kVA	Catalog Number	Case Style	Approx. Dimensions - Inches [mm]			Approx. Weight Lbs [kg]	Mtg Type W - Wall F - Floor	Wiring Diagram
			Width	Depth	Height			
15	SG3L0015HE0C	DH1-1	22.30 [566]	23.80 [604]	26.70 [678]	175 [79]	F or W/C*	SCD 6
25	SG3L0025HE0C	DH1-1	22.30 [566]	23.80 [604]	26.70 [678]	230 [104]	F or W/C*	SCD 6
37.5	SG3L0037HE0C	DH1-1	22.30 [566]	23.80 [604]	26.70 [678]	300 [136]	F or W/C*	SCD 6
50	SG3L0050HE0C	DH2	25.75 [654]	23.75 [603]	28.75 [730]	350 [159]	F or W/C*	SCD 6
75	SG3L0075HE0C	DH3	28.25 [717]	27.00 [686]	36.00 [914]	520 [236]	F (Opt W/C)	SCD 6
100	SG3L0100HE0C	DH3	28.25 [717]	27.00 [686]	36.00 [914]	630 [286]	F (Opt W/C)	SCD 6
150	SG3L0150HE0C	DH4	31.50 [800]	29.50 [749]	44.50 [1130]	920 [417]	F	SCD 39
167	SG3L0167HE0C	DH4	31.50 [800]	29.50 [749]	44.50 [1130]	980 [444]	F	SCD 39

600 PRIMARY VOLTS

120/240 SECONDARY VOLTS

60 HZ

kVA	Catalog Number	Case Style	Approx. Dimensions - Inches [mm]			Approx. Weight Lbs [kg]	Mtg Type W - Wall F - Floor	Wiring Diagram
			Width	Depth	Height			
15	SG3L0015PE0C	DH1-1	22.30 [566]	23.80 [604]	26.70 [678]	175 [79]	F or W/C*	SCD 6
25	SG3L0025PE0C	DH1-1	22.30 [566]	23.80 [604]	26.70 [678]	230 [104]	F or W/C*	SCD 6
37.5	SG3L0037PE0C	DH1-1	22.30 [566]	23.80 [604]	26.70 [678]	300 [136]	F or W/C*	SCD 6
50	SG3L0050PE0C	DH2	25.75 [654]	23.75 [603]	28.75 [730]	350 [159]	F or W/C*	SCD 6
75	SG3L0075PE0C	DH3	28.25 [717]	27.00 [686]	36.00 [914]	520 [236]	F (Opt W/C)	SCD 6
100	SG3L0100PE0C	DH3	28.25 [717]	27.00 [686]	36.00 [914]	630 [286]	F (Opt W/C)	SCD 6
150	SG3L0150PE0C	DH4	31.50 [800]	29.50 [749]	44.50 [1130]	920 [417]	F	SCD 39
167	SG3L0167PE0C	DH4	31.50 [800]	29.50 [749]	44.50 [1130]	980 [444]	F	SCD 39

*W/C: Built-in Wall Ceiling Mounting Opt W/C: Wall Ceiling Mounting Kit "DW3" Available

SELECTION TABLES

GENERAL PURPOSE DISTRIBUTION TRANSFORMERS

Copper Wound, Single Phase



EXPORT MODEL

190/200/208/220 X 380/400/416/440 PRIMARY VOLTS 120/240 SECONDARY VOLTS

50/60 HZ**

kVA	Catalog Number	Case Style	Approx. Dimensions - Inches [mm]			Approx. Weight Lbs [kg]	Mtg Type W - Wall F - Floor	Wiring Diagram
			Width	Depth	Height			
15	SG3M0015XE0C	DH1-1	22.30 [566]	23.80 [604]	26.70 [678]	175 [79]	F or W/C*	SCD 30
25	SG3M0025XE0C	DH1-1	22.30 [566]	23.80 [604]	26.70 [678]	230 [104]	F or W/C*	SCD 30
37.5	SG3M0037XE0C	DH1-1	22.30 [566]	23.80 [604]	26.70 [678]	300 [136]	F or W/C*	SCD 30
50	SG3M0050XE0C	DH2	25.75 [654]	23.75 [603]	28.75 [730]	350 [159]	F or W/C*	SCD 30
75	SG3M0075XE0C	DH3	28.25 [717]	27.00 [686]	36.00 [914]	520 [286]	F (Opt W/C)	SCD 30
100	SG3M0100XE0C	DH3	28.25 [717]	27.00 [686]	36.00 [914]	630 [286]	F (Opt W/C)	SCD 30
150	SG3M0150XE0C	Please contact your HPS Sales Representative						
167	SG3M0167XE0C	Please contact your HPS Sales Representative						

*W/C: Built-in Wall Ceiling Mounting Opt W/C: Wall Ceiling Mounting Kit "DW3" Available

**Note: Meets DOE 2016/NRCan 2019 at 60 Hz.

Aluminum Wound, Three Phase

208 DELTA PRIMARY VOLTS

208Y/120 SECONDARY VOLTS

60 HZ

kVA	Catalog Number	Case Style	Approx. Dimensions - Inches [mm]			Approx. Weight Lbs [kg]	Mtg Type W - Wall F - Floor	Wiring Diagram
			Width	Depth	Height			
15	SG3A0015BB	DH1	21.5 [546]	20.1 [510]	22.0 [559]	210 [95]	F or W/C*	SCD 19
30	SG3A0030BB	DH2	25.8 [655]	23.8 [604]	28.8 [731]	310 [141]	F or W/C*	SCD 19
45	SG3A0045BB	DH2	25.8 [655]	23.8 [604]	28.8 [731]	380 [172]	F or W/C*	SCD 19
75	SG3A0075BB	DH3	28.3 [719]	27.0 [686]	36.0 [914]	510 [231]	F (Opt W/C)	SCD 19
112.5	SG3A0112BB	DH3	28.3 [719]	27.0 [686]	36.0 [914]	680 [308]	F (Opt W/C)	SCD 19
150	SG3A0150BB	DH4	31.5 [800]	29.5 [749]	44.5 [1130]	870 [395]	F	SCD 19
225	SG3A0225BB	DH5	38.0 [965]	34.0 [864]	52.0 [1321]	1350 [612]	F	SCD 7A
300	SG3A0300BB	DH5	38.0 [965]	34.0 [864]	52.0 [1321]	1800 [816]	F	SCD 7A
500	SG3A0500BB	DH6	49.0 [1245]	42.0 [1067]	64.0 [1627]	2750 [1247]	F	SCD 8
505	SG3A0505BB	DH6	49.0 [1245]	42.0 [1067]	64.0 [1627]	2750 [1247]	F	SCD 8
750	SG3A0750BB	DH7	54.0 [1372]	47.0 [1194]	72.0 [1829]	4100 [1860]	F	SCD 60
1000	SG3A1000BB	DH8	60.0 [1524]	50.0 [1270]	82.0 [2083]	5400 [2449]	F	SCD 60

208 DELTA PRIMARY VOLTS

480Y/277 SECONDARY VOLTS

60 HZ

kVA	Catalog Number	Case Style	Approx. Dimensions - Inches [mm]			Approx. Weight Lbs [kg]	Mtg Type W - Wall F - Floor	Wiring Diagram
			Width	Depth	Height			
15	SG3A0015BK	DH1	21.5 [546]	20.1 [510]	22.0 [559]	210 [95]	F or W/C*	SCD 53
30	SG3A0030BK	DH2	25.8 [655]	23.8 [604]	28.8 [731]	310 [141]	F or W/C*	SCD 53
45	SG3A0045BK	DH2	25.8 [655]	23.8 [604]	28.8 [731]	380 [172]	F or W/C*	SCD 53
75	SG3A0075BK	DH3	28.3 [719]	27.0 [686]	36.0 [914]	510 [231]	F (Opt W/C)	SCD 53
112.5	SG3A0112BK	DH3	28.3 [719]	27.0 [686]	36.0 [914]	680 [308]	F (Opt W/C)	SCD 53
150	SG3A0150BK	DH4	31.5 [800]	29.5 [749]	44.5 [1130]	870 [395]	F	SCD 53
225	SG3A0225BK	DH5	38.0 [965]	34.0 [864]	52.0 [1321]	1350 [612]	F	SCD 56
300	SG3A0300BK	DH5	38.0 [965]	34.0 [864]	52.0 [1321]	1800 [816]	F	SCD 56
500	SG3A0500BK	DH6	49.0 [1245]	42.0 [1067]	64.0 [1627]	2750 [1247]	F	SCD 23A
505	SG3A0505BK	DH6	49.0 [1245]	42.0 [1067]	64.0 [1627]	2750 [1247]	F	SCD 23A
750	SG3A0750BK	DH7	54.0 [1372]	47.0 [1194]	72.0 [1829]	4100 [1860]	F	SCD 61
1000	SG3A1000BK	DH8	60.0 [1524]	50.0 [1270]	82.0 [2083]	5400 [2449]	F	SCD 61

*W/C: Built-in Wall Ceiling Mounting Opt W/C: Wall Ceiling Mounting Kit "DW3" Available

SELECTION TABLES

GENERAL PURPOSE DISTRIBUTION TRANSFORMERS



Aluminum Wound, Three Phase

240 DELTA PRIMARY VOLTS 208Y/120 SECONDARY VOLTS 60 HZ

kVA	Catalog Number	Case Style	Approx. Dimensions - Inches [mm]			Approx. Weight Lbs [kg]	Mtg Type W - Wall F - Floor	Wiring Diagram
			Width	Depth	Height			
15	SG3A0015DB	DH1	21.5 [546]	20.1 [510]	22.0 [559]	210 [95]	F or W/C*	SCD 19
30	SG3A0030DB	DH2	25.8 [655]	23.8 [604]	28.8 [731]	310 [141]	F or W/C*	SCD 19
45	SG3A0045DB	DH2	25.8 [655]	23.8 [604]	28.8 [731]	380 [172]	F or W/C*	SCD 19
75	SG3A0075DB	DH3	28.3 [719]	27.0 [686]	36.0 [914]	510 [231]	F (Opt W/C)	SCD 19
112.5	SG3A0112DB	DH3	28.3 [719]	27.0 [686]	36.0 [914]	680 [308]	F (Opt W/C)	SCD 19
150	SG3A0150DB	DH4	31.5 [800]	29.5 [749]	44.5 [1130]	870 [395]	F	SCD 19
225	SG3A0225DB	DH5	38.0 [965]	34.0 [864]	52.0 [1321]	1350 [612]	F	SCD 7A
300	SG3A0300DB	DH5	38.0 [965]	34.0 [864]	52.0 [1321]	1800 [816]	F	SCD 7A
500	SG3A0500DB	DH6	49.0 [1245]	42.0 [1067]	64.0 [1627]	2750 [1247]	F	SCD 8
505	SG3A0505DB	DH6	49.0 [1245]	42.0 [1067]	64.0 [1627]	2750 [1247]	F	SCD 8
750	SG3A0750DB	DH7	54.0 [1372]	47.0 [1194]	72.0 [1829]	4100 [1860]	F	SCD 60
1000	SG3A1000DB	DH8	60.0 [1524]	50.0 [1270]	82.0 [2083]	5400 [2449]	F	SCD 60

240 DELTA PRIMARY VOLTS 480Y/277 SECONDARY VOLTS 60 HZ

kVA	Catalog Number	Case Style	Approx. Dimensions - Inches [mm]			Approx. Weight Lbs [kg]	Mtg Type W - Wall F - Floor	Wiring Diagram
			Width	Depth	Height			
15	SG3A0015DK	DH1	21.5 [546]	20.1 [510]	22.0 [559]	210 [95]	F or W/C*	SCD 53
30	SG3A0030DK	DH2	25.8 [655]	23.8 [604]	28.8 [731]	310 [141]	F or W/C*	SCD 53
45	SG3A0045DK	DH2	25.8 [655]	23.8 [604]	28.8 [731]	380 [172]	F or W/C*	SCD 53
75	SG3A0075DK	DH3	28.3 [719]	27.0 [686]	36.0 [914]	510 [231]	F (Opt W/C)	SCD 53
112.5	SG3A0112DK	DH3	28.3 [719]	27.0 [686]	36.0 [914]	680 [308]	F (Opt W/C)	SCD 53
150	SG3A0150DK	DH4	31.5 [800]	29.5 [749]	44.5 [1130]	870 [395]	F	SCD 53
225	SG3A0225DK	DH5	38.0 [965]	34.0 [864]	52.0 [1321]	1350 [612]	F	SCD 56
300	SG3A0300DK	DH5	38.0 [965]	34.0 [864]	52.0 [1321]	1800 [816]	F	SCD 56
500	SG3A0500DK	DH6	49.0 [1245]	42.0 [1067]	64.0 [1626]	2750 [1247]	F	SCD 23A
505	SG3A0505DK	DH6	49.0 [1245]	42.0 [1067]	64.0 [1626]	2750 [1247]	F	SCD 23A
750	SG3A0750DK	DH7	54.0 [1372]	47.0 [1194]	72.0 [1829]	4100 [1860]	F	SCD 61
1000	SG3A1000DK	DH8	60.0 [1524]	50.0 [1270]	82.0 [2083]	5400 [2449]	F	SCD 61

480 DELTA PRIMARY VOLTS 208Y/120 SECONDARY VOLTS 60 HZ

kVA	Catalog Number	Case Style	Approx. Dimensions - Inches [mm]			Approx. Weight Lbs [kg]	Mtg Type W - Wall F - Floor	Wiring Diagram
			Width	Depth	Height			
15	SG3A0015KB	DH1	21.5 [546]	20.1 [510]	22.0 [559]	210 [95]	F or W/C*	SCD 19
30	SG3A0030KB	DH2	25.8 [655]	23.8 [604]	28.8 [731]	310 [141]	F or W/C*	SCD 19
45	SG3A0045KB	DH2	25.8 [655]	23.8 [604]	28.8 [731]	380 [172]	F or W/C*	SCD 19
75	SG3A0075KB	DH3	28.3 [719]	27.0 [686]	36.0 [914]	510 [231]	F (Opt W/C)	SCD 19
112.5	SG3A0112KB	DH3	28.3 [719]	27.0 [686]	36.0 [914]	680 [308]	F (Opt W/C)	SCD 19
150	SG3A0150KB	DH4	31.5 [800]	29.5 [749]	44.5 [1130]	870 [395]	F	SCD 19
225	SG3A0225KB	DH5	38.0 [965]	34.0 [864]	52.0 [1321]	1350 [612]	F	SCD 19
300	SG3A0300KB	DH5	38.0 [965]	34.0 [864]	52.0 [1321]	1800 [816]	F	SCD 19
500	SG3A0500KB	DH6	49.0 [1245]	42.0 [1067]	64.0 [1626]	2750 [1247]	F	SCD 20
505	SG3A0505KB	DH6	49.0 [1245]	42.0 [1067]	64.0 [1626]	2750 [1247]	F	SCD 20
750	SG3A0750KB	DH7	54.0 [1372]	47.0 [1194]	72.0 [1829]	4100 [1860]	F	SCD 20
1000	SG3A1000KB	DH8	60.0 [1524]	50.0 [1270]	82.0 [2083]	5400 [2449]	F	SCD 10

*W/C: Built-in Wall Ceiling Mounting Opt W/C: Wall Ceiling Mounting Kit "DW3" Available

GENERAL PURPOSE DISTRIBUTION TRANSFORMERS



Aluminum Wound, Three Phase

480 DELTA PRIMARY VOLTS 240 DELTA/120 CT SECONDARY VOLTS 60 HZ

kVA	Catalog Number	Case Style	Approx. Dimensions - Inches [mm]			Approx. Weight Lbs [kg]	Mtg Type W - Wall F - Floor	Wiring Diagram
			Width	Depth	Height			
15	SG3C0015KD	DH1	21.5 [546]	20.1 [510]	22.0 [559]	210 [95]	F or W/C*	SCD 21
30	SG3C0030KD	DH2	25.8 [655]	23.8 [604]	28.8 [731]	310 [141]	F or W/C*	SCD 21
45	SG3C0045KD	DH2	25.8 [655]	23.8 [604]	28.8 [731]	380 [172]	F or W/C*	SCD 21
75	SG3C0075KD	DH3	28.3 [719]	27.0 [686]	36.0 [914]	510 [231]	F (Opt W/C)	SCD 21
112.5	SG3C0112KD	DH3	28.3 [719]	27.0 [686]	36.0 [914]	680 [308]	F (Opt W/C)	SCD 21
150	SG3C0150KD	DH4	31.5 [800]	29.5 [749]	44.5 [1130]	870 [395]	F	SCD 21
225	SG3C0225KD	DH5	38.0 [965]	34.0 [864]	52.0 [1321]	1350 [612]	F	SCD 21
300	SG3C0300KD	DH5	38.0 [965]	34.0 [864]	52.0 [1321]	1800 [816]	F	SCD 21
500	SG3C0500KD	DH6	49.0 [1245]	42.0 [1067]	64.0 [1626]	2750 [1247]	F	SCD 22
505	SG3C0505KD	DH6	49.0 [1245]	42.0 [1067]	64.0 [1626]	2750 [1247]	F	SCD 22
750	SG3C0750KD	DH7	54.0 [1372]	47.0 [1194]	72.0 [1829]	4100 [1860]	F	SCD 22
1000	SG3C1000KD	DH8	60.0 [1524]	50.0 [1270]	82.0 [2083]	5400 [2449]	F	SCD 59

480 DELTA PRIMARY VOLTS 380Y/220, 400Y/231, 416Y/240, 430Y/248 SECONDARY VOLTS 60 HZ

kVA	Catalog Number	Case Style	Approx. Dimensions - Inches [mm]			Approx. Weight Lbs [kg]	Mtg Type W - Wall F - Floor	Wiring Diagram
			Width	Depth	Height			
15	SG3A0015KY	DH1	21.5 [546]	20.1 [510]	22.0 [559]	210 [95]	F or W/C*	SCD 52
30	SG3A0030KY	DH2	25.8 [655]	23.8 [604]	28.8 [731]	310 [141]	F or W/C*	SCD 52
45	SG3A0045KY	DH2	25.8 [655]	23.8 [604]	28.8 [731]	380 [172]	F or W/C*	SCD 52
75	SG3A0075KY	DH3	28.3 [719]	27.0 [686]	36.0 [914]	510 [231]	F (Opt W/C)	SCD 52
112.5	SG3A0112KY	DH3	28.3 [719]	27.0 [686]	36.0 [914]	680 [308]	F (Opt W/C)	SCD 52
150	SG3A0150KY	DH4	31.5 [800]	29.5 [749]	44.5 [1130]	870 [395]	F	SCD 52
225	SG3A0225KY	DH5	38 [965]	34.0 [864]	52.0 [1321]	1350 [612]	F	SCD 52
300	SG3A0300KY	DH5	38 [965]	34.0 [864]	52.0 [1321]	2100 [952]	F	SCD 52
500	SG3A0500KY	DH7	54.0 [1372]	47 [1194]	72.0 [1829]	3300 [1497]	F	SCD 70
505	SG3A0505KY	DH7	54.0 [1372]	47 [1194]	72.0 [1829]	3300 [1497]	F	SCD 70
750	SG3A0750KY	DH7	54.0 [1372]	47 [1194]	72.0 [1829]	5100 [2313]	F	SCD 70
1000	SG3A1000KY		Please contact your HPS Sales Representative					

480 PRIMARY VOLTS 480Y/277 SECONDARY VOLTS 60 HZ

kVA	Catalog Number	Case Style	Approx. Dimensions - Inches [mm]			Approx. Weight Lbs [kg]	Mtg Type W - Wall F - Floor	Wiring Diagram
			Width	Depth	Height			
15	SG3A0015KK	DH1	21.5 [546]	20.1 [510]	22.0 [559]	210 [95]	F or W/C*	SCD 19
30	SG3A0030KK	DH2	25.8 [655]	23.8 [604]	28.8 [731]	310 [141]	F or W/C*	SCD 19
45	SG3A0045KK	DH2	25.8 [655]	23.8 [604]	28.8 [731]	380 [172]	F or W/C*	SCD 19
75	SG3A0075KK	DH3	28.3 [719]	27.0 [686]	36.0 [914]	510 [231]	F (Opt W/C)	SCD 19
112.5	SG3A0112KK	DH3	28.3 [719]	27.0 [686]	36.0 [914]	680 [308]	F (Opt W/C)	SCD 19
150	SG3A0150KK	DH4	31.5 [800]	29.5 [749]	44.5 [1130]	870 [395]	F	SCD 19
225	SG3A0225KK	DH5	38.0 [965]	34.0 [864]	52.0 [1321]	1350 [612]	F	SCD 19
300	SG3A0300KK	DH5	38.0 [965]	34.0 [864]	52.0 [1321]	1800 [816]	F	SCD 19
500	SG3A0500KK	DH6	49.0 [1245]	42.0 [1067]	64.0 [1626]	2750 [1247]	F	SCD 20
505	SG3A0505KK	DH6	49.0 [1245]	42.0 [1067]	64.0 [1626]	2750 [1247]	F	SCD 20
750	SG3A0750KK	DH7	54.0 [1372]	47.0 [1194]	72.0 [1829]	4100 [1860]	F	SCD 20
1000	SG3A1000KK	DH8	60.0 [1524]	50.0 [1270]	82.0 [2083]	5400 [2449]	F	SCD 10

SELECTION TABLES

GENERAL PURPOSE DISTRIBUTION TRANSFORMERS



Aluminum Wound, Three Phase

600 DELTA PRIMARY VOLTS 208Y/120 SECONDARY VOLTS 60 HZ

kVA	Catalog Number	Case Style	Approx. Dimensions - Inches [mm]			Approx. Weight Lbs [kg]	Mtg Type W - Wall F - Floor	Wiring Diagram
			Width	Depth	Height			
15	SG3A0015PB	DH1	21.5 [546]	20.1 [510]	22.0 [559]	210 [95]	F or W/C*	SCD 19
30	SG3A0030PB	DH2	25.8 [655]	23.8 [604]	28.8 [731]	310 [141]	F or W/C*	SCD 19
45	SG3A0045PB	DH2	25.8 [655]	23.8 [604]	28.8 [731]	380 [172]	F or W/C*	SCD 19
75	SG3A0075PB	DH3	28.3 [719]	27.0 [686]	36.0 [914]	510 [231]	F (Opt W/C)	SCD 19
112.5	SG3A0112PB	DH3	28.3 [719]	27.0 [686]	36.0 [914]	680 [308]	F (Opt W/C)	SCD 19
150	SG3A0150PB	DH4	31.5 [800]	29.5 [749]	44.5 [1130]	870 [395]	F	SCD 19
225	SG3A0225PB	DH5	38.0 [965]	34.0 [864]	52.0 [1321]	1350 [612]	F	SCD 19
300	SG3A0300PB	DH5	38.0 [965]	34.0 [864]	52.0 [1321]	1800 [816]	F	SCD 19
500	SG3A0500PB	DH6	49.0 [1245]	42.0 [1067]	64.0 [1626]	2750 [1247]	F	SCD 20
505	SG3A0505PB	DH6	49.0 [1245]	42.0 [1067]	64.0 [1626]	2750 [1247]	F	SCD 20
750	SG3A0750PB	DH7	54.0 [1372]	47.0 [1194]	72.0 [1829]	4100 [1860]	F	SCD 20
1000	SG3A1000PB	DH8	60.0 [1524]	50.0 [1270]	82.0 [2083]	5400 [2449]	F	SCD 10

600 DELTA PRIMARY VOLTS 480Y/277 SECONDARY VOLTS 60 HZ

kVA	Catalog Number	Case Style	Approx. Dimensions - Inches [mm]			Approx. Weight Lbs [kg]	Mtg Type W - Wall F - Floor	Wiring Diagram
			Width	Depth	Height			
15	SG3A0015PK	DH1	21.5 [546]	20.1 [510]	22.0 [559]	210 [95]	F or W/C*	SCD 19
30	SG3A0030PK	DH2	25.8 [655]	23.8 [604]	28.8 [731]	310 [141]	F or W/C*	SCD 19
45	SG3A0045PK	DH2	25.8 [655]	23.8 [604]	28.8 [731]	380 [172]	F or W/C*	SCD 19
75	SG3A0075PK	DH3	28.3 [719]	27.0 [686]	36.0 [914]	510 [231]	F (Opt W/C)	SCD 19
112.5	SG3A0112PK	DH3	28.3 [719]	27.0 [686]	36.0 [914]	680 [308]	F (Opt W/C)	SCD 19
150	SG3A0150PK	DH4	31.5 [800]	29.5 [749]	44.5 [1130]	870 [395]	F	SCD 19
225	SG3A0225PK	DH5	38.0 [965]	34.0 [864]	52.0 [1321]	1350 [612]	F	SCD 19
300	SG3A0300PK	DH5	38.0 [965]	34.0 [864]	52.0 [1321]	1800 [816]	F	SCD 19
500	SG3A0500PK	DH6	49.0 [1245]	42.0 [1067]	64.0 [1626]	2750 [1247]	F	SCD 20
505	SG3A0505PK	DH6	49.0 [1245]	42.0 [1067]	64.0 [1626]	2750 [1247]	F	SCD 20
750	SG3A0750PK	DH7	54.0 [1372]	47.0 [1194]	72.0 [1829]	4100 [1860]	F	SCD 20
1000	SG3A1000PK	DH8	60.0 [1524]	50.0 [1270]	82.0 [2083]	5400 [2449]	F	SCD 10

Copper Wound, Three Phase

208 DELTA PRIMARY VOLTS 208Y/120 SECONDARY VOLTS 60 HZ

kVA	Catalog Number	Case Style	Approx. Dimensions - Inches [mm]			Approx. Weight Lbs [kg]	Mtg Type W - Wall F - Floor	Wiring Diagram
			Width	Depth	Height			
15	SG3A0015BB0C	DH1	21.5 [546]	20.1 [510]	22.0 [559]	210 [95]	F or W/C*	SCD 19
30	SG3A0030BB0C	DH2	25.8 [655]	23.8 [604]	28.8 [731]	340 [154]	F or W/C*	SCD 19
45	SG3A0045BB0C	DH2	25.8 [655]	23.8 [604]	28.8 [731]	400 [181]	F or W/C*	SCD 19
75	SG3A0075BB0C	DH3	28.3 [719]	27.0 [686]	36.0 [914]	590 [268]	F (Opt W/C)	SCD 19
112.5	SG3A0112BB0C	DH3	28.3 [719]	27.0 [686]	36.0 [914]	740 [336]	F (Opt W/C)	SCD 19
150	SG3A0150BB0C	DH4	31.5 [800]	29.5 [749]	44.5 [1130]	930 [422]	F	SCD 19
225	SG3A0225BB0C	DH4	31.5 [800]	29.5 [749]	44.5 [1130]	1350 [612]	F	SCD 7A
300	SG3A0300BB0C	DH5	38.0 [965]	34.0 [864]	52.0 [1321]	1800 [816]	F	SCD 7A
500	SG3A0500BB0C	DH6	49.0 [1245]	42.0 [1067]	64.0 [1626]	3200 [1451]	F	SCD 8
505	SG3A0505BB0C	DH6	49.0 [1245]	42.0 [1067]	64.0 [1626]	3200 [1451]	F	SCD 8
750	SG3A0750BB0C	DH6	49.0 [1245]	42.0 [1067]	64.0 [1626]	4050 [1837]	F	SCD 60
1000	SG3A1000BB0C	DH7	54.0 [1372]	47.0 [1194]	72.0 [1829]	5200 [2359]	F	SCD 60

*W/C: Built-in Wall Ceiling Mounting Opt W/C: Wall Ceiling Mounting Kit "DW3" Available

GENERAL PURPOSE DISTRIBUTION TRANSFORMERS



Copper Wound, Three Phase

208 DELTA PRIMARY VOLTS 480Y/277 SECONDARY VOLTS 60 HZ

kVA	Catalog Number	Case Style	Approx. Dimensions - Inches [mm]			Approx. Weight Lbs [kg]	Mtg Type W - Wall F - Floor	Wiring Diagram
			Width	Depth	Height			
15	SG3A0015BK0C	DH1	21.5 [546]	20.1 [510]	22.0 [559]	210 [95]	F or W/C*	SCD 53
30	SG3A0030BK0C	DH2	25.8 [655]	23.8 [604]	28.8 [731]	340 [154]	F or W/C*	SCD 53
45	SG3A0045BK0C	DH2	25.8 [655]	23.8 [604]	28.8 [731]	400 [181]	F or W/C*	SCD 53
75	SG3A0075BK0C	DH3	28.3 [719]	27.0 [686]	36.0 [914]	590 [268]	F (Opt W/C)	SCD 53
112.5	SG3A0112BK0C	DH3	28.3 [719]	27.0 [686]	36.0 [914]	740 [336]	F (Opt W/C)	SCD 53
150	SG3A0150BK0C	DH4	31.5 [800]	29.5 [749]	44.5 [1130]	930 [422]	F	SCD 53
225	SG3A0225BK0C	DH4	31.5 [800]	29.5 [749]	44.5 [1130]	1350 [612]	F	SCD 56
300	SG3A0300BK0C	DH5	38.0 [965]	34.0 [864]	52.0 [1321]	1800 [816]	F	SCD 56
500	SG3A0500BK0C	DH6	49.0 [1245]	42.0 [1067]	64.0 [1626]	3200 [1451]	F	SCD 23A
505	SG3A0505BK0C	DH6	49.0 [1245]	42.0 [1067]	64.0 [1626]	3200 [1451]	F	SCD 23A
750	SG3A0750BK0C	DH6	49.0 [1245]	42.0 [1067]	64.0 [1626]	4050 [1837]	F	SCD 61
1000	SG3A1000BK0C	DH7	54.0 [1372]	47.0 [1194]	72.0 [1829]	5200 [2359]	F	SCD 61

240 DELTA PRIMARY VOLTS 208Y/120 SECONDARY VOLTS 60 HZ

kVA	Catalog Number	Case Style	Approx. Dimensions - Inches [mm]			Approx. Weight Lbs [kg]	Mtg Type W - Wall F - Floor	Wiring Diagram
			Width	Depth	Height			
15	SG3A0015DB0C	DH1	21.5 [546]	20.1 [510]	22.0 [559]	210 [95]	F or W/C*	SCD 19
30	SG3A0030DB0C	DH2	25.8 [655]	23.8 [604]	28.8 [731]	340 [154]	F or W/C*	SCD 19
45	SG3A0045DB0C	DH2	25.8 [655]	23.8 [604]	28.8 [731]	400 [181]	F or W/C*	SCD 19
75	SG3A0075DB0C	DH3	28.3 [719]	27.0 [686]	36.0 [914]	590 [268]	F (Opt W/C)	SCD 19
112.5	SG3A0112DB0C	DH3	28.3 [719]	27.0 [686]	36.0 [914]	740 [336]	F (Opt W/C)	SCD 19
150	SG3A0150DB0C	DH4	31.5 [800]	29.5 [749]	44.5 [1130]	930 [422]	F	SCD 19
225	SG3A0225DB0C	DH4	31.5 [800]	29.5 [749]	44.5 [1130]	1350 [612]	F	SCD 7A
300	SG3A0300DB0C	DH5	38.0 [965]	34.0 [864]	52.0 [1321]	1800 [816]	F	SCD 7A
500	SG3A0500DB0C	DH6	49.0 [1245]	42.0 [1067]	64.0 [1626]	3200 [1451]	F	SCD 8
505	SG3A0505DB0C	DH6	49.0 [1245]	42.0 [1067]	64.0 [1626]	3200 [1451]	F	SCD 8
750	SG3A0750DB0C	DH6	49.0 [1245]	42.0 [1067]	64.0 [1626]	4050 [1837]	F	SCD 60
1000	SG3A1000DB0C	DH7	54.0 [1372]	47.0 [1194]	72.0 [1829]	5200 [2359]	F	SCD 60

240 DELTA PRIMARY VOLTS 480Y/277 SECONDARY VOLTS 60 HZ

kVA	Catalog Number	Case Style	Approx. Dimensions - Inches [mm]			Approx. Weight Lbs [kg]	Mtg Type W - Wall F - Floor	Wiring Diagram
			Width	Depth	Height			
15	SG3A0015DK0C	DH1	21.5 [546]	20.1 [510]	22.0 [559]	210 [95]	F or W/C*	SCD 53
30	SG3A0030DK0C	DH2	25.8 [655]	23.8 [604]	28.8 [731]	340 [154]	F or W/C*	SCD 53
45	SG3A0045DK0C	DH2	25.8 [655]	23.8 [604]	28.8 [731]	400 [181]	F or W/C*	SCD 53
75	SG3A0075DK0C	DH3	28.3 [719]	27.0 [686]	36.0 [914]	590 [268]	F (Opt W/C)	SCD 53
112.5	SG3A0112DK0C	DH3	28.3 [719]	27.0 [686]	36.0 [914]	740 [336]	F (Opt W/C)	SCD 53
150	SG3A0150DK0C	DH4	31.5 [800]	29.5 [749]	44.5 [1130]	930 [422]	F	SCD 53
225	SG3A0225DK0C	DH4	31.5 [800]	29.5 [749]	44.5 [1130]	1350 [612]	F	SCD 56
300	SG3A0300DK0C	DH5	38.0 [965]	34.0 [864]	52.0 [1321]	1800 [816]	F	SCD 56
500	SG3A0500DK0C	DH6	49.0 [1245]	42.0 [1067]	64.0 [1626]	3200 [1451]	F	SCD 23A
505	SG3A0505DK0C	DH6	49.0 [1245]	42.0 [1067]	64.0 [1626]	3200 [1451]	F	SCD 23A
750	SG3A0750DK0C	DH6	49.0 [1245]	42.0 [1067]	64.0 [1626]	4050 [1837]	F	SCD 61
1000	SG3A1000DK0C	DH7	54.0 [1372]	47.0 [1194]	72.0 [1829]	5200 [2359]	F	SCD 61

*W/C: Built-in Wall Ceiling Mounting Opt W/C: Wall Ceiling Mounting Kit "DW3" Available

SELECTION TABLES

GENERAL PURPOSE DISTRIBUTION TRANSFORMERS



Copper Wound, Three Phase

480 DELTA PRIMARY VOLTS

208Y/120 SECONDARY VOLTS

60 HZ

kVA	Catalog Number	Case Style	Approx. Dimensions - Inches [mm]			Approx. Weight Lbs [kg]	Mtg Type W - Wall F - Floor	Wiring Diagram
			Width	Depth	Height			
15	SG3A0015KB0C	DH1	21.5 [546]	20.1 [510]	22.0 [559]	210 [95]	F or W/C*	SCD 19
30	SG3A0030KB0C	DH2	25.8 [655]	23.8 [604]	28.8 [731]	340 [154]	F or W/C*	SCD 19
45	SG3A0045KB0C	DH2	25.8 [655]	23.8 [604]	28.8 [731]	400 [181]	F or W/C*	SCD 19
75	SG3A0075KB0C	DH3	28.3 [719]	27.0 [686]	36.0 [914]	590 [268]	F (Opt W/C)	SCD 19
112.5	SG3A0112KB0C	DH3	28.3 [719]	27.0 [686]	36.0 [914]	740 [336]	F (Opt W/C)	SCD 19
150	SG3A0150KB0C	DH4	31.5 [800]	29.5 [749]	44.5 [1130]	930 [422]	F	SCD 19
225	SG3A0225KB0C	DH4	31.5 [800]	29.5 [749]	44.5 [1130]	1350 [612]	F	SCD 19
300	SG3A0300KB0C	DH5	38.0 [965]	34.0 [864]	52.0 [1321]	1800 [816]	F	SCD 19
500	SG3A0500KB0C	DH6	49.0 [1245]	42.0 [1067]	64.0 [1626]	3200 [1451]	F	SCD 20
505	SG3A0505KB0C	DH6	49.0 [1245]	42.0 [1067]	64.0 [1626]	3200 [1451]	F	SCD 20
750	SG3A0750KB0C	DH6	49.0 [1245]	42.0 [1067]	64.0 [1626]	4050 [1837]	F	SCD 20
1000	SG3A1000KB0C	DH7	54.0 [1372]	47.0 [1194]	72.0 [1829]	5200 [2359]	F	SCD 10

480 DELTA PRIMARY VOLTS

240 DELTA/120 CT SECONDARY VOLTS

60 HZ

kVA	Catalog Number	Case Style	Approx. Dimensions - Inches [mm]			Approx. Weight Lbs [kg]	Mtg Type W - Wall F - Floor	Wiring Diagram
			Width	Depth	Height			
15	SG3C0015KD0C	DH1	21.5 [546]	20.1 [510]	22.0 [559]	210 [95]	F or W/C*	SCD 21
30	SG3C0030KD0C	DH2	25.8 [655]	23.8 [604]	28.8 [711]	340 [154]	F or W/C*	SCD 21
45	SG3C0045KD0C	DH2	25.8 [655]	23.8 [604]	28.8 [711]	400 [181]	F or W/C*	SCD 21
75	SG3C0075KD0C	DH3	28.3 [719]	27.0 [686]	36.0 [914]	590 [267]	F (Opt W/C)	SCD 21
112.5	SG3C0112KD0C	DH3	28.3 [719]	27.0 [686]	36.0 [914]	740 [336]	F (Opt W/C)	SCD 21
150	SG3C0150KD0C	DH4	31.5 [800]	29.5 [749]	44.5 [1130]	930 [422]	F	SCD 21
225	SG3C0225KD0C	DH4	31.5 [800]	29.5 [749]	44.5 [1130]	1350 [612]	F	SCD 21
300	SG3C0300KD0C	DH5	38.0 [965]	34.0 [864]	52.0 [1321]	1800 [816]	F	SCD 21
500	SG3C0500KD0C	DH6	49.0 [1245]	42.0 [1067]	64.0 [1626]	3200 [1451]	F	SCD 22
505	SG3C0505KD0C	DH6	49.0 [1245]	42.0 [1067]	64.0 [1626]	3200 [1451]	F	SCD 22
750	SG3C0750KD0C	DH6	49.0 [1245]	42.0 [1067]	64.0 [1626]	4050 [1837]	F	SCD 22
1000	SG3C1000KD0C	DH7	54.0 [1372]	47.0 [1194]	72.0 [1829]	5200 [2359]	F	SCD 59

480 DELTA PRIMARY VOLTS

380Y, 400Y, 416Y, 430Y SECONDARY VOLTS

60 HZ

kVA	Catalog Number	Case Style	Approx. Dimensions - Inches [mm]			Approx. Weight Lbs [kg]	Mtg Type W - Wall F - Floor	Wiring Diagram
			Width	Depth	Height			
15	SG3A0015KY0C	DH1	21.5 [546]	20.1 [510]	22.0 [559]	210 [95]	F or W/C*	SCD 52
30	SG3A0030KY0C	DH2	25.8 [655]	23.8 [604]	28.8 [711]	340 [154]	F or W/C*	SCD 52
45	SG3A0045KY0C	DH2	25.8 [655]	23.8 [604]	28.8 [711]	400 [181]	F or W/C*	SCD 52
75	SG3A0075KY0C	DH3	28.3 [719]	27.0 [686]	36.0 [914]	590 [267]	F (Opt W/C)	SCD 52
112.5	SG3A0112KY0C	DH3	28.3 [719]	27.0 [686]	36.0 [914]	740 [336]	F (Opt W/C)	SCD 52
150	SG3A0150KY0C	DH4	31.5 [800]	29.5 [749]	44.5 [1130]	930 [422]	F	SCD 52
225	SG3A0225KY0C	DH4	31.5 [800]	29.5 [749]	44.5 [1130]	1350 [612]	F	SCD 52
300	SG3A0300KY0C	DH5	38 [965]	34.0 [864]	52.0 [1321]	2100 [952]	F	SCD 52
500	SG3A0500KY0C	DH6	49.0 [1245]	42 [1067]	64.0 [1626]	3500 [1587]	F	SCD 70
505	SG3A0505KY0C	DH6	49.0 [1245]	42 [1067]	64.0 [1626]	3500 [1587]	F	SCD 70
750	SG3A0750KY0C	DH7	54.0 [1372]	47 [1194]	72.0 [1829]	5300 [2404]	F	SCD 70
1000	SG3A1000KY0C		Please contact your HPS Sales Representative					

*W/C: Built-in Wall Ceiling Mounting Opt W/C: Wall Ceiling Mounting Kit "DW3" Available

SELECTION TABLES

GENERAL PURPOSE DISTRIBUTION TRANSFORMERS



Copper Wound, Three Phase

480 DELTA PRIMARY VOLTS

480Y/277 SECONDARY VOLTS

60 HZ

kVA	Catalog Number	Case Style	Approx. Dimensions - Inches [mm]			Approx. Weight Lbs [kg]	Mtg Type W - Wall F - Floor	Wiring Diagram
			Width	Depth	Height			
15	SG3A0015KK0C	DH1	21.5 [546]	20.1 [510]	22.0 [559]	210 [95]	F or W/C*	SCD 19
30	SG3A0030KK0C	DH2	25.8 [655]	23.8 [604]	28.8 [711]	340 [154]	F or W/C*	SCD 19
45	SG3A0045KK0C	DH2	25.8 [655]	23.8 [604]	28.8 [711]	400 [181]	F or W/C*	SCD 19
75	SG3A0075KK0C	DH3	28.3 [719]	27.0 [686]	36.0 [914]	590 [267]	F (Opt W/C)	SCD 19
112.5	SG3A0112KK0C	DH3	28.3 [719]	27.0 [686]	36.0 [914]	740 [336]	F (Opt W/C)	SCD 19
150	SG3A0150KK0C	DH4	31.5 [800]	29.5 [749]	44.5 [1130]	930 [422]	F	SCD 19
225	SG3A0225KK0C	DH4	31.5 [800]	29.5 [749]	44.5 [1130]	1350 [612]	F	SCD 19
300	SG3A0300KK0C	DH5	38.0 [965]	34.0 [864]	52.0 [1321]	1800 [816]	F	SCD 19
500	SG3A0500KK0C	DH6	49.0 [1245]	42.0 [1067]	64.0 [1626]	3200 [1451]	F	SCD 20
505	SG3A0505KK0C	DH6	49.0 [1245]	42.0 [1067]	64.0 [1626]	3200 [1451]	F	SCD 20
750	SG3A0750KK0C	DH6	49.0 [1245]	42.0 [1067]	64.0 [1626]	4050 [1837]	F	SCD 20
1000	SG3A1000KK0C	DH7	54.0 [1372]	47.0 [1194]	72.0 [1829]	5200 [2359]	F	SCD 10

600 DELTA PRIMARY VOLTS

208Y/120 SECONDARY VOLTS

60 HZ

kVA	Catalog Number	Case Style	Approx. Dimensions - Inches [mm]			Approx. Weight Lbs [kg]	Mtg Type W - Wall F - Floor	Wiring Diagram
			Width	Depth	Height			
15	SG3A0015PB0C	DH1	21.5 [546]	20.1 [511]	22 [559]	210 [95]	F or W/C*	SCD 19
30	SG3A0030PB0C	DH2	25.8 [655]	23.8 [605]	28.8 [732]	340 [154]	F or W/C*	SCD 19
45	SG3A0045PB0C	DH2	25.8 [655]	23.8 [605]	28.8 [732]	400 [181]	F or W/C*	SCD 19
75	SG3A0075PB0C	DH3	28.3 [719]	27 [686]	36 [914]	590 [268]	F (Opt W/C)	SCD 19
112.5	SG3A0112PB0C	DH3	28.3 [719]	27 [686]	36 [914]	740 [336]	F (Opt W/C)	SCD 19
150	SG3A0150PB0C	DH4	31.5 [800]	29.5 [749]	44.5 [1130]	930 [422]	F	SCD 19
225	SG3A0225PB0C	DH4	31.5 [800]	29.5 [749]	44.5 [1130]	1350 [612]	F	SCD 19
300	SG3A0300PB0C	DH5	38 [965]	34 [864]	52 [1321]	1800 [816]	F	SCD 19
500	SG3A0500PB0C	DH6	49 [1245]	42 [1067]	64 [1626]	3200 [1451]	F	SCD 20
505	SG3A0505PB0C	DH6	49 [1245]	42 [1067]	64 [1626]	3200 [1451]	F	SCD 20
750	SG3A0750PB0C	DH6	49 [1245]	42 [1067]	64 [1626]	4050 [1837]	F	SCD 20
1000	SG3A1000PB0C	DH7	54 [1372]	47 [1194]	72 [1829]	5200 [2359]	F	SCD 10

600 DELTA PRIMARY VOLTS

480Y/277 SECONDARY VOLTS

60 HZ

kVA	Catalog Number	Case Style	Approx. Dimensions - Inches [mm]			Approx. Weight Lbs [kg]	Mtg Type W - Wall F - Floor	Wiring Diagram
			Width	Depth	Height			
15	SG3A0015PK0C	DH1	21.5 [546]	20.1 [511]	22 [559]	210 [95]	F or W/C*	SCD 19
30	SG3A0030PK0C	DH2	25.8 [655]	23.8 [605]	28.8 [732]	340 [154]	F or W/C*	SCD 19
45	SG3A0045PK0C	DH2	25.8 [655]	23.8 [605]	28.8 [732]	400 [181]	F or W/C*	SCD 19
75	SG3A0075PK0C	DH3	28.3 [719]	27 [686]	36 [914]	590 [268]	F (Opt W/C)	SCD 19
112.5	SG3A0112PK0C	DH3	28.3 [719]	27 [686]	36 [914]	740 [336]	F (Opt W/C)	SCD 19
150	SG3A0150PK0C	DH4	31.5 [800]	29.5 [749]	44.5 [1130]	930 [422]	F	SCD 19
225	SG3A0225PK0C	DH4	31.5 [800]	29.5 [749]	44.5 [1130]	1350 [612]	F	SCD 19
300	SG3A0300PK0C	DH5	38 [965]	34 [864]	52 [1321]	1800 [816]	F	SCD 19
500	SG3A0500PK0C	DH6	49 [1245]	42 [1067]	64 [1626]	3200 [1451]	F	SCD 20
505	SG3A0505PK0C	DH6	49 [1245]	42 [1067]	64 [1626]	3200 [1451]	F	SCD 20
750	SG3A0750PK0C	DH6	49 [1245]	42 [1067]	64 [1626]	4050 [1837]	F	SCD 20
1000	SG3A1000PK0C	DH7	54 [1372]	47 [1194]	72 [1829]	5200 [2359]	F	SCD 10

*W/C: Built-in Wall Ceiling Mounting Opt W/C: Wall Ceiling Mounting Kit "DW3" Available

SELECTION TABLES

K-RATED DISTRIBUTION TRANSFORMERS



K-Factor 4, Aluminum Wound, Shielded, Three Phase

480 DELTA PRIMARY VOLTS

208Y/120 SECONDARY VOLTS

60 HZ

kVA	Catalog Number	Case Style	Approx. Dimensions - Inches [mm]			Approx. Weight Lbs [kg]	Mtg Type W - Wall F - Floor	Wiring Diagram
			Width	Depth	Height			
15	SK3A0015KB4S	DH1	21.5 [546]	20.13 [511]	22 [559]	220 [100]	F or W/C*	SCD 19
30	SK3A0030KB4S	DH2	25.8 [655]	23.8 [605]	28.8 [732]	320 [145]	F or W/C*	SCD 19
45	SK3A0045KB4S	DH2	25.8 [655]	23.8 [605]	28.8 [732]	390 [177]	F or W/C*	SCD 19
75	SK3A0075KB4S	DH3	28.3 [719]	27 [686]	36 [914]	530 [240]	F (Opt W/C)	SCD 19
112.5	SK3A0112KB4S	DH3	28.3 [719]	27 [686]	36 [914]	690 [313]	F (Opt W/C)	SCD 19
150	SK3A0150KB4S	DH4	31.5 [800]	29.5 [749]	44.5 [1130]	900 [408]	F	SCD 19
225	SK3A0225KB4S	DH5	38 [965]	34 [864]	52 [1321]	1380 [626]	F	SCD 19
300	SK3A0300KB4S	DH5	38 [965]	34 [864]	52 [1321]	1830 [830]	F	SCD 19
500	SK3A0500KB4S	DH6	49 [1245]	42 [1067]	64 [1626]	2800 [1270]	F	SCD 20
505	SK3A0505KB4S	DH6	49 [1245]	42 [1067]	64 [1626]	2800 [1270]	F	SCD 20
750	SK3A0750KB4S	DH7	54 [1372]	47 [1194]	72 [1829]	4200 [1905]	F	SCD 20
1000	SK3A1000KB4S	DH8	60 [1524]	50 [1270]	82 [2083]	5500 [2495]	F	SCD 10

480 DELTA PRIMARY VOLTS

480Y/277 SECONDARY VOLTS

60 HZ

kVA	Catalog Number	Case Style	Approx. Dimensions - Inches [mm]			Approx. Weight Lbs [kg]	Mtg Type W - Wall F - Floor	Wiring Diagram
			Width	Depth	Height			
15	SK3A0015KK4S	DH1	21.5 [546]	20.13 [511]	22 [559]	220 [100]	F or W/C*	SCD 19
30	SK3A0030KK4S	DH2	25.8 [655]	23.8 [605]	28.8 [732]	320 [145]	F or W/C*	SCD 19
45	SK3A0045KK4S	DH2	25.8 [655]	23.8 [605]	28.8 [732]	390 [177]	F or W/C*	SCD 19
75	SK3A0075KK4S	DH3	28.3 [719]	27 [686]	36 [914]	530 [240]	F (Opt W/C)	SCD 19
112.5	SK3A0112KK4S	DH3	28.3 [719]	27 [686]	36 [914]	690 [313]	F (Opt W/C)	SCD 19
150	SK3A0150KK4S	DH4	31.5 [800]	29.5 [749]	44.5 [1130]	900 [408]	F	SCD 19
225	SK3A0225KK4S	DH5	38 [965]	34 [864]	52 [1321]	1380 [626]	F	SCD 19
300	SK3A0300KK4S	DH5	38 [965]	34 [864]	52 [1321]	1830 [830]	F	SCD 19
500	SK3A0500KK4S	DH6	49 [1245]	42 [1067]	64 [1626]	2800 [1270]	F	SCD 20
505	SK3A0505KK4S	DH6	49 [1245]	42 [1067]	64 [1626]	2800 [1270]	F	SCD 20
750	SK3A0750KK4S	DH7	54 [1372]	47 [1194]	72 [1829]	4200 [1905]	F	SCD 20
1000	SK3A1000KK4S	DH8	60 [1524]	50 [1270]	82 [2083]	5500 [2495]	F	SCD 10

600 DELTA PRIMARY VOLTS

208Y/120 SECONDARY VOLTS

60 HZ

kVA	Catalog Number	Case Style	Approx. Dimensions - Inches [mm]			Approx. Weight Lbs [kg]	Mtg Type W - Wall F - Floor	Wiring Diagram
			Width	Depth	Height			
15	SK3A0015PB4S	DH1	21.5 [546]	20.13 [511]	22 [559]	220 [100]	F or W/C*	SCD 19
30	SK3A0030PB4S	DH2	25.8 [655]	23.8 [605]	28.8 [732]	320 [145]	F or W/C*	SCD 19
45	SK3A0045PB4S	DH2	25.8 [655]	23.8 [605]	28.8 [732]	390 [177]	F or W/C*	SCD 19
75	SK3A0075PB4S	DH3	28.3 [719]	27 [686]	36 [914]	530 [240]	F (Opt W/C)	SCD 19
112.5	SK3A0112PB4S	DH3	28.3 [719]	27 [686]	36 [914]	690 [313]	F (Opt W/C)	SCD 19
150	SK3A0150PB4S	DH4	31.5 [800]	29.5 [749]	44.5 [1130]	900 [408]	F	SCD 19
225	SK3A0225PB4S	DH5	38 [965]	34 [864]	52 [1321]	1380 [626]	F	SCD 19
300	SK3A0300PB4S	DH5	38 [965]	34 [864]	52 [1321]	1830 [830]	F	SCD 19
500	SK3A0500PB4S	DH6	49 [1245]	42 [1067]	64 [1626]	2800 [1270]	F	SCD 20
505	SK3A0505PB4S	DH6	49 [1245]	42 [1067]	64 [1626]	2800 [1270]	F	SCD 20
750	SK3A0750PB4S	DH7	54 [1372]	47 [1194]	72 [1829]	4200 [1905]	F	SCD 20
1000	SK3A1000PB4S	DH8	60 [1524]	50 [1270]	82 [2083]	5500 [2495]	F	SCD 10

600 DELTA PRIMARY VOLTS

488Y/277 SECONDARY VOLTS

60 HZ

kVA	Catalog Number	Case Style	Approx. Dimensions - Inches [mm]			Approx. Weight Lbs [kg]	Mtg Type W - Wall F - Floor	Wiring Diagram
			Width	Depth	Height			
15	SK3A0015PK4S	DH1	21.5 [546]	20.13 [511]	22 [559]	220 [100]	F or W/C*	SCD 19
30	SK3A0030PK4S	DH2	25.8 [655]	23.8 [605]	28.8 [732]	320 [145]	F or W/C*	SCD 19
45	SK3A0045PK4S	DH2	25.8 [655]	23.8 [605]	28.8 [732]	390 [177]	F or W/C*	SCD 19
75	SK3A0075PK4S	DH3	28.3 [719]	27 [686]	36 [914]	530 [240]	F (Opt W/C)	SCD 19
112.5	SK3A0112PK4S	DH3	28.3 [719]	27 [686]	36 [914]	690 [313]	F (Opt W/C)	SCD 19
150	SK3A0150PK4S	DH4	31.5 [800]	29.5 [749]	44.5 [1130]	900 [408]	F	SCD 19
225	SK3A0225PK4S	DH5	38 [965]	34 [864]	52 [1321]	1380 [626]	F	SCD 19
300	SK3A0300PK4S	DH5	38 [965]	34 [864]	52 [1321]	1830 [830]	F	SCD 19
500	SK3A0500PK4S	DH6	49 [1245]	42 [1067]	64 [1626]	2800 [1270]	F	SCD 20
505	SK3A0505PK4S	DH6	49 [1245]	42 [1067]	64 [1626]	2800 [1270]	F	SCD 20
750	SK3A0750PK4S	DH7	54 [1372]	47 [1194]	72 [1829]	4200 [1905]	F	SCD 20
1000	SK3A1000PK4S	DH8	60 [1524]	50 [1270]	82 [2083]	5500 [2495]	F	SCD 10

*W/C: Built-in Wall Ceiling Mounting Opt W/C: Wall Ceiling Mounting Kit "DW3" Available

SELECTION TABLES

K-RATED DISTRIBUTION TRANSFORMERS



K-Factor 4, Copper Wound, Shielded, Three Phase

480 DELTA PRIMARY VOLTS

208Y/120 SECONDARY VOLTS

60 HZ

kVA	Catalog Number	Case Style	Approx. Dimensions - Inches [mm]			Approx. Weight Lbs [kg]	Mtg Type W - Wall F - Floor	Wiring Diagram
			Width	Depth	Height			
15	SK3A0015KB4K	DH1	21.5[546]	20.13[511]	22[559]	220[100]	F or W/C*	SCD 19
30	SK3A0030KB4K	DH2	25.8[655]	23.8[605]	28.8[732]	350[159]	F or W/C*	SCD 19
45	SK3A0045KB4K	DH2	25.8[655]	23.8[605]	28.8[732]	410[186]	F or W/C*	SCD 19
75	SK3A0075KB4K	DH3	28.3[719]	27[686]	36[914]	600[272]	F (Opt W/C)	SCD 19
112.5	SK3A0112KB4K	DH3	28.3[719]	27[686]	36[914]	760[345]	F (Opt W/C)	SCD 19
150	SK3A0150KB4K	DH4	31.5[800]	29.5[749]	44.5[1130]	950[431]	F	SCD 19
225	SK3A0225KB4K	DH4	31.5[800]	29.5[749]	44.5[1130]	1380[626]	F	SCD 19
300	SK3A0300KB4K	DH5	38[965]	34[864]	52[1321]	1830[830]	F	SCD 19
500	SK3A0500KB4K	DH6	49[1245]	42[1067]	64[1626]	3250[1474]	F	SCD 20
505	SK3A0505KB4K	DH6	49[1245]	42[1067]	64[1626]	3250[1474]	F	SCD 20
750	SK3A0750KB4K	DH6	49[1245]	42[1067]	64[1626]	4100[1860]	F	SCD 20
1000	SK3A1000KB4K	DH7	54[1372]	47[1194]	72[1829]	5300[2404]	F	SCD 10

480 DELTA PRIMARY VOLTS

480Y/277 SECONDARY VOLTS

60 HZ

kVA	Catalog Number	Case Style	Approx. Dimensions - Inches [mm]			Approx. Weight Lbs [kg]	Mtg Type W - Wall F - Floor	Wiring Diagram
			Width	Depth	Height			
15	SK3A0015KK4K	DH1	21.5 [546]	20.13 [511]	22 [559]	220 [100]	F or W/C*	SCD 19
30	SK3A0030KK4K	DH2	25.8 [655]	23.8 [605]	28.8 [732]	350 [159]	F or W/C*	SCD 19
45	SK3A0045KK4K	DH2	25.8 [655]	23.8 [605]	28.8 [732]	410 [186]	F or W/C*	SCD 19
75	SK3A0075KK4K	DH3	28.3 [719]	27 [686]	36 [914]	600 [272]	F (Opt W/C)	SCD 19
112.5	SK3A0112KK4K	DH3	28.3 [719]	27 [686]	36 [914]	760 [345]	F (Opt W/C)	SCD 19
150	SK3A0150KK4K	DH4	31.5 [800]	29.5 [749]	44.5 [1130]	950 [431]	F	SCD 19
225	SK3A0225KK4K	DH4	31.5 [800]	29.5 [749]	44.5 [1130]	1380 [626]	F	SCD 19
300	SK3A0300KK4K	DH5	38 [965]	34 [864]	52 [1321]	1830 [830]	F	SCD 19
500	SK3A0500KK4K	DH6	49 [1245]	42 [1067]	64 [1626]	3250 [1474]	F	SCD 20
505	SK3A0505KK4K	DH6	49 [1245]	42 [1067]	64 [1626]	3250 [1474]	F	SCD 20
750	SK3A0750KK4K	DH6	49 [1245]	42 [1067]	64 [1626]	4100 [1860]	F	SCD 20
1000	SK3A1000KK4K	DH7	54 [1372]	47 [1194]	72 [1829]	5300 [2404]	F	SCD 10

600 DELTA PRIMARY VOLTS

208Y/120 SECONDARY VOLTS

60 HZ

kVA	Catalog Number	Case Style	Approx. Dimensions - Inches [mm]			Approx. Weight Lbs [kg]	Mtg Type W - Wall F - Floor	Wiring Diagram
			Width	Depth	Height			
15	SK3A0015PB4K	DH1	21.5 [546]	20.13 [511]	22 [559]	220 [100]	F or W/C*	SCD 19
30	SK3A0030PB4K	DH2	25.8 [655]	23.8 [605]	28.8 [732]	350 [159]	F or W/C*	SCD 19
45	SK3A0045PB4K	DH2	25.8 [655]	23.8 [605]	28.8 [732]	410 [186]	F or W/C*	SCD 19
75	SK3A0075PB4K	DH3	28.3 [719]	27 [686]	36 [914]	600 [272]	F (Opt W/C)	SCD 19
112.5	SK3A0112PB4K	DH3	28.3 [719]	27 [686]	36 [914]	760 [345]	F (Opt W/C)	SCD 19
150	SK3A0150PB4K	DH4	31.5 [800]	29.5 [749]	44.5 [1130]	950 [431]	F	SCD 19
225	SK3A0225PB4K	DH4	31.5 [800]	29.5 [749]	44.5 [1130]	1380 [626]	F	SCD 19
300	SK3A0300PB4K	DH5	38 [965]	34 [864]	52 [1321]	1830 [830]	F	SCD 19
500	SK3A0500PB4K	DH6	49 [1245]	42 [1067]	64 [1626]	3250 [1474]	F	SCD 20
505	SK3A0505PB4K	DH6	49 [1245]	42 [1067]	64 [1626]	3250 [1474]	F	SCD 20
750	SK3A0750PB4K	DH6	49 [1245]	42 [1067]	64 [1626]	4100 [1860]	F	SCD 20
1000	SK3A1000PB4K	DH7	54 [1372]	47 [1194]	72 [1829]	5300 [2404]	F	SCD 10

600 DELTA PRIMARY VOLTS

480Y/277 SECONDARY VOLTS

60 HZ

kVA	Catalog Number	Case Style	Approx. Dimensions - Inches [mm]			Approx. Weight Lbs [kg]	Mtg Type W - Wall F - Floor	Wiring Diagram
			Width	Depth	Height			
15	SK3A0015PK4K	DH1	21.5 [546]	20.13 [511]	22 [559]	220 [100]	F or W/C*	SCD 19
30	SK3A0030PK4K	DH2	25.8 [655]	23.8 [605]	28.8 [732]	350 [159]	F or W/C*	SCD 19
45	SK3A0045PK4K	DH2	25.8 [655]	23.8 [605]	28.8 [732]	410 [186]	F or W/C*	SCD 19
75	SK3A0075PK4K	DH3	28.3 [719]	27 [686]	36 [914]	600 [272]	F (Opt W/C)	SCD 19
112.5	SK3A0112PK4K	DH3	28.3 [719]	27 [686]	36 [914]	760 [345]	F (Opt W/C)	SCD 19
150	SK3A0150PK4K	DH4	31.5 [800]	29.5 [749]	44.5 [1130]	950 [431]	F	SCD 19
225	SK3A0225PK4K	DH4	31.5 [800]	29.5 [749]	44.5 [1130]	1380 [626]	F	SCD 19
300	SK3A0300PK4K	DH5	38 [965]	34 [864]	52 [1321]	1830 [830]	F	SCD 19
500	SK3A0500PK4K	DH6	49 [1245]	42 [1067]	64 [1626]	3250 [1474]	F	SCD 20
505	SK3A0505PK4K	DH6	49 [1245]	42 [1067]	64 [1626]	3250 [1474]	F	SCD 20
750	SK3A0750PK4K	DH6	49 [1245]	42 [1067]	64 [1626]	4100 [1860]	F	SCD 20
1000	SK3A1000PK4K	DH7	54 [1372]	47 [1194]	72 [1829]	5300 [2404]	F	SCD 10

*W/C: Built-in Wall Ceiling Mounting Opt W/C: Wall Ceiling Mounting Kit "DW3" Available

SELECTION TABLES

K-RATED DISTRIBUTION TRANSFORMERS

K-Factor 9, Aluminum Wound, Shielded, Three Phase



480 DELTA PRIMARY VOLTS

208Y/120 SECONDARY VOLTS

60 HZ

kVA	Catalog Number	Case Style	Approx. Dimensions - Inches [mm]			Approx. Weight Lbs [kg]	Mtg Type W - Wall F - Floor	Wiring Diagram
			Width	Depth	Height			
15	SK3A0015KB9S	DH1	21.5 [546]	20.13 [511]	22 [559]	230 [104]	F or W/C*	SCD 19
30	SK3A0030KB9S	DH2	25.8 [655]	23.8 [605]	28.8 [732]	330 [150]	F or W/C*	SCD 19
45	SK3A0045KB9S	DH2	25.8 [655]	23.8 [605]	28.8 [732]	410 [186]	F or W/C*	SCD 19
75	SK3A0075KB9S	DH3	28.3 [719]	27 [686]	36 [914]	550 [249]	F (Opt W/C)	SCD 19
112.5	SK3A0112KB9S	DH3	28.3 [719]	27 [686]	36 [914]	720 [327]	F (Opt W/C)	SCD 19
150	SK3A0150KB9S	DH4	31.5 [800]	29.5 [749]	44.5 [1130]	1040 [472]	F	SCD 19
225	SK3A0225KB9S	DH5	38 [965]	34 [864]	52 [1321]	1470 [667]	F	SCD 19
300	SK3A0300KB9S	DH5	38 [965]	34 [864]	52 [1321]	1930 [875]	F	SCD 19
500	SK3A0500KB9S	DH6	49 [1245]	42 [1067]	64 [1626]	2850 [1293]	F	SCD 20
505	SK3A0505KB9S	DH6	49 [1245]	42 [1067]	64 [1626]	2850 [1293]	F	SCD 20
750	SK3A0750KB9S	DH7	54 [1372]	47 [1194]	72 [1829]	4250 [1928]	F	SCD 20
1000	SK3A1000KB9S	DH8	60 [1524]	50 [1270]	82 [2083]	5600 [2540]	F	SCD 10

480 DELTA PRIMARY VOLTS

480Y/277 SECONDARY VOLTS

60 HZ

kVA	Catalog Number	Case Style	Approx. Dimensions - Inches [mm]			Approx. Weight Lbs [kg]	Mtg Type W - Wall F - Floor	Wiring Diagram
			Width	Depth	Height			
15	SK3A0015KK9S	DH1	21.5 [546]	20.13 [511]	22 [559]	230 [104]	F or W/C*	SCD 19
30	SK3A0030KK9S	DH2	25.8 [655]	23.8 [605]	28.8 [732]	330 [150]	F or W/C*	SCD 19
45	SK3A0045KK9S	DH2	25.8 [655]	23.8 [605]	28.8 [732]	410 [186]	F or W/C*	SCD 19
75	SK3A0075KK9S	DH3	28.3 [719]	27 [686]	36 [914]	550 [249]	F (Opt W/C)	SCD 19
112.5	SK3A0112KK9S	DH3	28.3 [719]	27 [686]	36 [914]	720 [327]	F (Opt W/C)	SCD 19
150	SK3A0150KK9S	DH4	31.5 [800]	29.5 [749]	44.5 [1130]	1040 [472]	F	SCD 19
225	SK3A0225KK9S	DH5	38 [965]	34 [864]	52 [1321]	1470 [667]	F	SCD 19
300	SK3A0300KK9S	DH5	38 [965]	34 [864]	52 [1321]	1930 [875]	F	SCD 19
500	SK3A0500KK9S	DH6	49 [1245]	42 [1067]	64 [1626]	2850 [1293]	F	SCD 20
505	SK3A0505KK9S	DH6	49 [1245]	42 [1067]	64 [1626]	2850 [1293]	F	SCD 20
750	SK3A0750KK9S	DH7	54 [1372]	47 [1194]	72 [1829]	4250 [1928]	F	SCD 20
1000	SK3A1000KK9S	DH8	60 [1524]	50 [1270]	82 [2083]	5600 [2540]	F	SCD 10

600 DELTA PRIMARY VOLTS

208Y/120 SECONDARY VOLTS

60 HZ

kVA	Catalog Number	Case Style	Approx. Dimensions - Inches [mm]			Approx. Weight Lbs [kg]	Mtg Type W - Wall F - Floor	Wiring Diagram
			Width	Depth	Height			
15	SK3A0015PB9S	DH1	21.5 [546]	20.13 [511]	22 [559]	230 [104]	F or W/C*	SCD 19
30	SK3A0030PB9S	DH2	25.8 [655]	23.8 [605]	28.8 [732]	330 [150]	F or W/C*	SCD 19
45	SK3A0045PB9S	DH2	25.8 [655]	23.8 [605]	28.8 [732]	410 [186]	F or W/C*	SCD 19
75	SK3A0075PB9S	DH3	28.3 [719]	27 [686]	36 [914]	550 [249]	F (Opt W/C)	SCD 19
112.5	SK3A0112PB9S	DH3	28.3 [719]	27 [686]	36 [914]	720 [327]	F (Opt W/C)	SCD 19
150	SK3A0150PB9S	DH4	31.5 [800]	29.5 [749]	44.5 [1130]	1040 [472]	F	SCD 19
225	SK3A0225PB9S	DH5	38 [965]	34 [864]	52 [1321]	1470 [667]	F	SCD 19
300	SK3A0300PB9S	DH5	38 [965]	34 [864]	52 [1321]	1930 [875]	F	SCD 19
500	SK3A0500PB9S	DH6	49 [1245]	42 [1067]	64 [1626]	2850 [1293]	F	SCD 20
505	SK3A0505PB9S	DH6	49 [1245]	42 [1067]	64 [1626]	2850 [1293]	F	SCD 20
750	SK3A0750PB9S	DH7	54 [1372]	47 [1194]	72 [1829]	4250 [1928]	F	SCD 20
1000	SK3A1000PB9S	DH8	60 [1524]	50 [1270]	82 [2083]	5600 [2540]	F	SCD 10

600 DELTA PRIMARY VOLTS

480Y/277 SECONDARY VOLTS

60 HZ

kVA	Catalog Number	Case Style	Approx. Dimensions - Inches [mm]			Approx. Weight Lbs [kg]	Mtg Type W - Wall F - Floor	Wiring Diagram
			Width	Depth	Height			
15	SK3A0015PK9S	DH1	21.5 [546]	20.13 [511]	22 [559]	230 [104]	F or W/C*	SCD 19
30	SK3A0030PK9S	DH2	25.8 [655]	23.8 [605]	28.8 [732]	330 [150]	F or W/C*	SCD 19
45	SK3A0045PK9S	DH2	25.8 [655]	23.8 [605]	28.8 [732]	410 [186]	F or W/C*	SCD 19
75	SK3A0075PK9S	DH3	28.3 [719]	27 [686]	36 [914]	550 [249]	F (Opt W/C)	SCD 19
112.5	SK3A0112PK9S	DH3	28.3 [719]	27 [686]	36 [914]	720 [327]	F (Opt W/C)	SCD 19
150	SK3A0150PK9S	DH4	31.5 [800]	29.5 [749]	44.5 [1130]	1040 [472]	F	SCD 19
225	SK3A0225PK9S	DH5	38 [965]	34 [864]	52 [1321]	1470 [667]	F	SCD 19
300	SK3A0300PK9S	DH5	38 [965]	34 [864]	52 [1321]	1930 [875]	F	SCD 19
500	SK3A0500PK9S	DH6	49 [1245]	42 [1067]	64 [1626]	2850 [1293]	F	SCD 20
505	SK3A0505PK9S	DH6	49 [1245]	42 [1067]	64 [1626]	2850 [1293]	F	SCD 20
750	SK3A0750PK9S	DH7	54 [1372]	47 [1194]	72 [1829]	4250 [1928]	F	SCD 20
1000	SK3A1000PK9S	DH8	60 [1524]	50 [1270]	82 [2083]	5600 [2540]	F	SCD 10

*W/C: Built-in Wall Ceiling Mounting Opt W/C: Wall Ceiling Mounting Kit "DW3" Available

SELECTION TABLES

K-RATED DISTRIBUTION TRANSFORMERS



K-Factor 9, Copper Wound, Shielded, Three Phase

480 DELTA PRIMARY VOLTS

208Y/120 SECONDARY VOLTS

60 HZ

kVA	Catalog Number	Case Style	Approx. Dimensions - Inches [mm]			Approx. Weight Lbs [kg]	Mtg Type W - Wall F - Floor	Wiring Diagram
			Width	Depth	Height			
15	SK3A0015KB9K	DH1	21.5 [546]	20.13 [511]	22 [559]	230 [104]	F or W/C*	SCD 19
30	SK3A0030KB9K	DH2	25.8 [655]	23.8 [605]	28.8 [732]	360 [163]	F or W/C*	SCD 19
45	SK3A0045KB9K	DH2	25.8 [655]	23.8 [605]	28.8 [732]	420 [191]	F or W/C*	SCD 19
75	SK3A0075KB9K	DH3	28.3 [719]	27 [686]	36 [914]	610 [277]	F (Opt W/C)	SCD 19
112.5	SK3A0112KB9K	DH3	28.3 [719]	27 [686]	36 [914]	830 [376]	F (Opt W/C)	SCD 19
150	SK3A0150KB9K	DH4	31.5 [800]	29.5 [749]	44.5 [1130]	1080 [490]	F	SCD 19
225	SK3A0225KB9K	DH4	31.5 [800]	29.5 [749]	44.5 [1130]	1600 [726]	F	SCD 19
300	SK3A0300KB9K	DH5	38 [965]	34 [864]	52 [1321]	2040 [925]	F	SCD 19
500	SK3A0500KB9K	DH6	49 [1245]	42 [1067]	64 [1626]	3300 [1497]	F	SCD 20
505	SK3A0505KB9K	DH6	49 [1245]	42 [1067]	64 [1626]	3300 [1497]	F	SCD 20
750	SK3A0750KB9K	DH6	49 [1245]	42 [1067]	64 [1626]	4400 [1996]	F	SCD 20
1000	SK3A1000KB9K	DH7	54 [1372]	47 [1194]	72 [1829]	5400 [2449]	F	SCD 10

480 DELTA PRIMARY VOLTS

480Y/277 SECONDARY VOLTS

60 HZ

kVA	Catalog Number	Case Style	Approx. Dimensions - Inches [mm]			Approx. Weight Lbs [kg]	Mtg Type W - Wall F - Floor	Wiring Diagram
			Width	Depth	Height			
15	SK3A0015KK9K	DH1	21.5 [546]	20.13 [511]	22 [559]	230 [104]	F or W/C*	SCD 19
30	SK3A0030KK9K	DH2	25.8 [655]	23.8 [605]	28.8 [732]	360 [163]	F or W/C*	SCD 19
45	SK3A0045KK9K	DH2	25.8 [655]	23.8 [605]	28.8 [732]	420 [191]	F or W/C*	SCD 19
75	SK3A0075KK9K	DH3	28.3 [719]	27 [686]	36 [914]	610 [277]	F (Opt W/C)	SCD 19
112.5	SK3A0112KK9K	DH3	28.3 [719]	27 [686]	36 [914]	830 [376]	F (Opt W/C)	SCD 19
150	SK3A0150KK9K	DH4	31.5 [800]	29.5 [749]	44.5 [1130]	1080 [490]	F	SCD 19
225	SK3A0225KK9K	DH4	31.5 [800]	29.5 [749]	44.5 [1130]	1600 [726]	F	SCD 19
300	SK3A0300KK9K	DH5	38 [965]	34 [864]	52 [1321]	2040 [925]	F	SCD 19
500	SK3A0500KK9K	DH6	49 [1245]	42 [1067]	64 [1626]	3300 [1497]	F	SCD 20
505	SK3A0505KK9K	DH6	49 [1245]	42 [1067]	64 [1626]	3300 [1497]	F	SCD 20
750	SK3A0750KK9K	DH6	49 [1245]	42 [1067]	64 [1626]	4400 [1996]	F	SCD 20
1000	SK3A1000KK9K	DH7	54 [1372]	47 [1194]	72 [1829]	5400 [2449]	F	SCD 10

600 DELTA PRIMARY VOLTS

208Y/120 SECONDARY VOLTS

60 HZ

kVA	Catalog Number	Case Style	Approx. Dimensions - Inches [mm]			Approx. Weight Lbs [kg]	Mtg Type W - Wall F - Floor	Wiring Diagram
			Width	Depth	Height			
15	SK3A0015PB9K	DH1	21.5 [546]	20.13 [511]	22 [559]	230 [104]	F or W/C*	SCD 19
30	SK3A0030PB9K	DH2	25.8 [655]	23.8 [605]	28.8 [732]	360 [163]	F or W/C*	SCD 19
45	SK3A0045PB9K	DH2	25.8 [655]	23.8 [605]	28.8 [732]	420 [191]	F or W/C*	SCD 19
75	SK3A0075PB9K	DH3	28.3 [719]	27 [686]	36 [914]	610 [277]	F (Opt W/C)	SCD 19
112.5	SK3A0112PB9K	DH3	28.3 [719]	27 [686]	36 [914]	830 [376]	F (Opt W/C)	SCD 19
150	SK3A0150PB9K	DH4	31.5 [800]	29.5 [749]	44.5 [1130]	1080 [490]	F	SCD 19
225	SK3A0225PB9K	DH4	31.5 [800]	29.5 [749]	44.5 [1130]	1600 [726]	F	SCD 19
300	SK3A0300PB9K	DH5	38 [965]	34 [864]	52 [1321]	2040 [925]	F	SCD 19
500	SK3A0500PB9K	DH6	49 [1245]	42 [1067]	64 [1626]	3300 [1497]	F	SCD 20
505	SK3A0505PB9K	DH6	49 [1245]	42 [1067]	64 [1626]	3300 [1497]	F	SCD 20
750	SK3A0750PB9K	DH6	49 [1245]	42 [1067]	64 [1626]	4400 [1996]	F	SCD 20
1000	SK3A1000PB9K	DH7	54 [1372]	47 [1194]	72 [1829]	5400 [2449]	F	SCD 10

600 DELTA PRIMARY VOLTS

480Y/277 SECONDARY VOLTS

60 HZ

kVA	Catalog Number	Case Style	Approx. Dimensions - Inches [mm]			Approx. Weight Lbs [kg]	Mtg Type W - Wall F - Floor	Wiring Diagram
			Width	Depth	Height			
15	SK3A0015PK9K	DH1	21.5 [546]	20.13 [511]	22 [559]	230 [104]	F or W/C*	SCD 19
30	SK3A0030PK9K	DH2	25.8 [655]	23.8 [605]	28.8 [732]	360 [163]	F or W/C*	SCD 19
45	SK3A0045PK9K	DH2	25.8 [655]	23.8 [605]	28.8 [732]	420 [191]	F or W/C*	SCD 19
75	SK3A0075PK9K	DH3	28.3 [719]	27 [686]	36 [914]	610 [277]	F (Opt W/C)	SCD 19
112.5	SK3A0112PK9K	DH3	28.3 [719]	27 [686]	36 [914]	830 [376]	F (Opt W/C)	SCD 19
150	SK3A0150PK9K	DH4	31.5 [800]	29.5 [749]	44.5 [1130]	1080 [490]	F	SCD 19
225	SK3A0225PK9K	DH4	31.5 [800]	29.5 [749]	44.5 [1130]	1600 [726]	F	SCD 19
300	SK3A0300PK9K	DH5	38 [965]	34 [864]	52 [1321]	2040 [925]	F	SCD 19
500	SK3A0500PK9K	DH6	49 [1245]	42 [1067]	64 [1626]	3300 [1497]	F	SCD 20
505	SK3A0505PK9K	DH6	49 [1245]	42 [1067]	64 [1626]	3300 [1497]	F	SCD 20
750	SK3A0750PK9K	DH6	49 [1245]	42 [1067]	64 [1626]	4400 [1996]	F	SCD 20
1000	SK3A1000PK9K	DH7	54 [1372]	47 [1194]	72 [1829]	5400 [2449]	F	SCD 10

*W/C: Built-in Wall Ceiling Mounting Opt W/C: Wall Ceiling Mounting Kit "DW3" Available

SELECTION TABLES

K-RATED DISTRIBUTION TRANSFORMERS



K-Factor 13, Aluminum Wound, Shielded, Three Phase

480 DELTA PRIMARY VOLTS

208Y/120 SECONDARY VOLTS

60 HZ

kVA	Catalog Number	Case Style	Approx. Dimensions - Inches [mm]			Approx. Weight Lbs [kg]	Mtg Type W - Wall F - Floor	Wiring Diagram
			Width	Depth	Height			
15	SK3A0015KB3S	DH1	21.5 [546]	20.13 [511]	22 [559]	240 [109]	F or W/C*	SCD 19
30	SK3A0030KB3S	DH2	25.8 [655]	23.8 [605]	28.8 [732]	340 [154]	F or W/C*	SCD 19
45	SK3A0045KB3S	DH2	25.8 [655]	23.8 [605]	28.8 [732]	420 [191]	F or W/C*	SCD 19
75	SK3A0075KB3S	DH3	28.3 [719]	27 [686]	36 [914]	560 [254]	F (Opt W/C)	SCD 19
112.5	SK3A0112KB3S	DH3	28.3 [719]	27 [686]	36 [914]	730 [331]	F (Opt W/C)	SCD 19
150	SK3A0150KB3S	DH4	31.5 [800]	29.5 [749]	44.5 [1130]	1070 [485]	F	SCD 19
225	SK3A0225KB3S	DH5	38 [965]	34 [864]	52 [1321]	1500 [680]	F	SCD 19
300	SK3A0300KB3S	DH5	38 [965]	34 [864]	52 [1321]	1950 [885]	F	SCD 19
500	SK3A0500KB3S	DH6	49 [1245]	42 [1067]	64 [1626]	2900 [1315]	F	SCD 20
505	SK3A0505KB3S	DH6	49 [1245]	42 [1067]	64 [1626]	2900 [1315]	F	SCD 20
750	SK3A0750KB3S	DH7	54 [1372]	47 [1194]	72 [1829]	4400 [1996]	F	SCD 20
1000	SK3A1000KB3S	DH8	60 [1524]	50 [1270]	82 [2083]	5700 [2585]	F	SCD 10

480 DELTA PRIMARY VOLTS

480Y/277 SECONDARY VOLTS

60 HZ

kVA	Catalog Number	Case Style	Approx. Dimensions - Inches [mm]			Approx. Weight Lbs [kg]	Mtg Type W - Wall F - Floor	Wiring Diagram
			Width	Depth	Height			
15	SK3A0015KK3S	DH1	21.5 [546]	20.13 [511]	22 [559]	240 [109]	F or W/C*	SCD 19
30	SK3A0030KK3S	DH2	25.8 [655]	23.8 [605]	28.8 [732]	340 [154]	F or W/C*	SCD 19
45	SK3A0045KK3S	DH2	25.8 [655]	23.8 [605]	28.8 [732]	420 [191]	F or W/C*	SCD 19
75	SK3A0075KK3S	DH3	28.3 [719]	27 [686]	36 [914]	560 [254]	F (Opt W/C)	SCD 19
112.5	SK3A0112KK3S	DH3	28.3 [719]	27 [686]	36 [914]	730 [331]	F (Opt W/C)	SCD 19
150	SK3A0150KK3S	DH4	31.5 [800]	29.5 [749]	44.5 [1130]	1070 [485]	F	SCD 19
225	SK3A0225KK3S	DH5	38 [965]	34 [864]	52 [1321]	1500 [680]	F	SCD 19
300	SK3A0300KK3S	DH5	38 [965]	34 [864]	52 [1321]	1950 [885]	F	SCD 19
500	SK3A0500KK3S	DH6	49 [1245]	42 [1067]	64 [1626]	2900 [1315]	F	SCD 20
505	SK3A0505KK3S	DH6	49 [1245]	42 [1067]	64 [1626]	2900 [1315]	F	SCD 20
750	SK3A0750KK3S	DH7	54 [1372]	47 [1194]	72 [1829]	4400 [1996]	F	SCD 20
1000	SK3A1000KK3S	DH8	60 [1524]	50 [1270]	82 [2083]	5700 [2585]	F	SCD 10

600 DELTA PRIMARY VOLTS

208Y/120 SECONDARY VOLTS

60 HZ

kVA	Catalog Number	Case Style	Approx. Dimensions - Inches [mm]			Approx. Weight Lbs [kg]	Mtg Type W - Wall F - Floor	Wiring Diagram
			Width	Depth	Height			
15	SK3A0015PB3S	DH1	21.5 [546]	20.13 [511]	22 [559]	240 [109]	F or W/C*	SCD 19
30	SK3A0030PB3S	DH2	25.8 [655]	23.8 [605]	28.8 [732]	340 [154]	F or W/C*	SCD 19
45	SK3A0045PB3S	DH2	25.8 [655]	23.8 [605]	28.8 [732]	420 [191]	F or W/C*	SCD 19
75	SK3A0075PB3S	DH3	28.3 [719]	27 [686]	36 [914]	560 [254]	F (Opt W/C)	SCD 19
112.5	SK3A0112PB3S	DH3	28.3 [719]	27 [686]	36 [914]	730 [331]	F (Opt W/C)	SCD 19
150	SK3A0150PB3S	DH4	31.5 [800]	29.5 [749]	44.5 [1130]	1070 [485]	F	SCD 19
225	SK3A0225PB3S	DH5	38 [965]	34 [864]	52 [1321]	1500 [680]	F	SCD 19
300	SK3A0300PB3S	DH5	38 [965]	34 [864]	52 [1321]	1950 [885]	F	SCD 19
500	SK3A0500PB3S	DH6	49 [1245]	42 [1067]	64 [1626]	2900 [1315]	F	SCD 20
505	SK3A0505PB3S	DH6	49 [1245]	42 [1067]	64 [1626]	2900 [1315]	F	SCD 20
750	SK3A0750PB3S	DH7	54 [1372]	47 [1194]	72 [1829]	4400 [1996]	F	SCD 20
1000	SK3A1000PB3S	DH8	60 [1524]	50 [1270]	82 [2083]	5700 [2585]	F	SCD 10

600 DELTA PRIMARY VOLTS

480Y/277 SECONDARY VOLTS

60 HZ

kVA	Catalog Number	Case Style	Approx. Dimensions - Inches [mm]			Approx. Weight Lbs [kg]	Mtg Type W - Wall F - Floor	Wiring Diagram
			Width	Depth	Height			
15	SK3A0015PK3S	DH1	21.5 [546]	20.13 [511]	22 [559]	240 [109]	F or W/C*	SCD 19
30	SK3A0030PK3S	DH2	25.8 [655]	23.8 [605]	28.8 [732]	340 [154]	F or W/C*	SCD 19
45	SK3A0045PK3S	DH2	25.8 [655]	23.8 [605]	28.8 [732]	420 [191]	F or W/C*	SCD 19
75	SK3A0075PK3S	DH3	28.3 [719]	27 [686]	36 [914]	560 [254]	F (Opt W/C)	SCD 19
112.5	SK3A0112PK3S	DH3	28.3 [719]	27 [686]	36 [914]	730 [331]	F (Opt W/C)	SCD 19
150	SK3A0150PK3S	DH4	31.5 [800]	29.5 [749]	44.5 [1130]	1070 [485]	F	SCD 19
225	SK3A0225PK3S	DH5	38 [965]	34 [864]	52 [1321]	1500 [680]	F	SCD 19
300	SK3A0300PK3S	DH5	38 [965]	34 [864]	52 [1321]	1950 [885]	F	SCD 19
500	SK3A0500PK3S	DH6	49 [1245]	42 [1067]	64 [1626]	2900 [1315]	F	SCD 20
505	SK3A0505PK3S	DH6	49 [1245]	42 [1067]	64 [1626]	2900 [1315]	F	SCD 20
750	SK3A0750PK3S	DH7	54 [1372]	47 [1194]	72 [1829]	4400 [1996]	F	SCD 20
1000	SK3A1000PK3S	DH8	60 [1524]	50 [1270]	82 [2083]	5700 [2585]	F	SCD 10

*W/C: Built-in Wall Ceiling Mounting Opt W/C: Wall Ceiling Mounting Kit "DW3" Available

SELECTION TABLES

K-RATED DISTRIBUTION TRANSFORMERS

K-Factor 13, Copper Wound, Shielded, Three Phase



480 DELTA PRIMARY VOLTS

208Y/120 SECONDARY VOLTS

60 HZ

kVA	Catalog Number	Case Style	Approx. Dimensions - Inches [mm]			Approx. Weight Lbs [kg]	Mtg Type W - Wall F - Floor	Wiring Diagram
			Width	Depth	Height			
15	SK3A0015KB3K	DH1	21.5 [546]	20.13 [511]	22 [559]	240 [109]	F or W/C*	SCD 19
30	SK3A0030KB3K	DH2	25.8 [655]	23.8 [605]	28.8 [732]	370 [168]	F or W/C*	SCD 19
45	SK3A0045KB3K	DH2	25.8 [655]	23.8 [605]	28.8 [732]	430 [195]	F or W/C*	SCD 19
75	SK3A0075KB3K	DH3	28.3 [719]	27 [686]	36 [914]	620 [281]	F (Opt W/C)	SCD 19
112.5	SK3A0112KB3K	DH3	28.3 [719]	27 [686]	36 [914]	840 [381]	F (Opt W/C)	SCD 19
150	SK3A0150KB3K	DH4	31.5 [800]	29.5 [749]	44.5 [1130]	1100 [499]	F	SCD 19
225	SK3A0225KB3K	DH4	31.5 [800]	29.5 [749]	44.5 [1130]	1620 [735]	F	SCD 19
300	SK3A0300KB3K	DH5	38 [965]	34 [864]	52 [1321]	2060 [934]	F	SCD 19
500	SK3A0500KB3K	DH6	49 [1245]	42 [1067]	64 [1626]	3400 [1542]	F	SCD 20
505	SK3A0505KB3K	DH6	49 [1245]	42 [1067]	64 [1626]	3400 [1542]	F	SCD 20
750	SK3A0750KB3K	DH6	49 [1245]	42 [1067]	64 [1626]	4500 [2041]	F	SCD 20
1000	SK3A1000KB3K	DH7	54 [1372]	47 [1194]	72 [1829]	5700 [2585]	F	SCD 10

480 DELTA PRIMARY VOLTS

480Y/277 SECONDARY VOLTS

60 HZ

kVA	Catalog Number	Case Style	Approx. Dimensions - Inches [mm]			Approx. Weight Lbs [kg]	Mtg Type W - Wall F - Floor	Wiring Diagram
			Width	Depth	Height			
15	SK3A0015KK3K	DH1	21.5 [546]	20.13 [511]	22 [559]	240 [109]	F or W/C*	SCD 19
30	SK3A0030KK3K	DH2	25.8 [655]	23.8 [605]	28.8 [732]	370 [168]	F or W/C*	SCD 19
45	SK3A0045KK3K	DH2	25.8 [655]	23.8 [605]	28.8 [732]	430 [195]	F or W/C*	SCD 19
75	SK3A0075KK3K	DH3	28.3 [719]	27 [686]	36 [914]	620 [281]	F (Opt W/C)	SCD 19
112.5	SK3A0112KK3K	DH3	28.3 [719]	27 [686]	36 [914]	840 [381]	F (Opt W/C)	SCD 19
150	SK3A0150KK3K	DH4	31.5 [800]	29.5 [749]	44.5 [1130]	1100 [499]	F	SCD 19
225	SK3A0225KK3K	DH4	31.5 [800]	29.5 [749]	44.5 [1130]	1620 [735]	F	SCD 19
300	SK3A0300KK3K	DH5	38 [965]	34 [864]	52 [1321]	2060 [934]	F	SCD 19
500	SK3A0500KK3K	DH6	49 [1245]	42 [1067]	64 [1626]	3400 [1542]	F	SCD 20
505	SK3A0505KK3K	DH6	49 [1245]	42 [1067]	64 [1626]	3400 [1542]	F	SCD 20
750	SK3A0750KK3K	DH6	49 [1245]	42 [1067]	64 [1626]	4500 [2041]	F	SCD 20
1000	SK3A1000KK3K	DH7	54 [1372]	47 [1194]	72 [1829]	5700 [2585]	F	SCD 10

600 DELTA PRIMARY VOLTS

208Y/120 SECONDARY VOLTS

60 HZ

kVA	Catalog Number	Case Style	Approx. Dimensions - Inches [mm]			Approx. Weight Lbs [kg]	Mtg Type W - Wall F - Floor	Wiring Diagram
			Width	Depth	Height			
15	SK3A0015PB3K	DH1	21.5 [546]	20.13 [511]	22 [559]	240 [109]	F or W/C*	SCD 19
30	SK3A0030PB3K	DH2	25.8 [655]	23.8 [605]	28.8 [732]	370 [168]	F or W/C*	SCD 19
45	SK3A0045PB3K	DH2	25.8 [655]	23.8 [605]	28.8 [732]	430 [195]	F or W/C*	SCD 19
75	SK3A0075PB3K	DH3	28.3 [719]	27 [686]	36 [914]	620 [281]	F (Opt W/C)	SCD 19
112.5	SK3A0112PB3K	DH3	28.3 [719]	27 [686]	36 [914]	840 [381]	F (Opt W/C)	SCD 19
150	SK3A0150PB3K	DH4	31.5 [800]	29.5 [749]	44.5 [1130]	1100 [499]	F	SCD 19
225	SK3A0225PB3K	DH4	31.5 [800]	29.5 [749]	44.5 [1130]	1620 [735]	F	SCD 19
300	SK3A0300PB3K	DH5	38 [965]	34 [864]	52 [1321]	2060 [934]	F	SCD 19
500	SK3A0500PB3K	DH6	49 [1245]	42 [1067]	64 [1626]	3400 [1542]	F	SCD 20
505	SK3A0505PB3K	DH6	49 [1245]	42 [1067]	64 [1626]	3400 [1542]	F	SCD 20
750	SK3A0750PB3K	DH6	49 [1245]	42 [1067]	64 [1626]	4500 [2041]	F	SCD 20
1000	SK3A1000PB3K	DH7	54 [1372]	47 [1194]	72 [1829]	5700 [2585]	F	SCD 10

600 DELTA PRIMARY VOLTS

480Y/277 SECONDARY VOLTS

60 HZ

kVA	Catalog Number	Case Style	Approx. Dimensions - Inches [mm]			Approx. Weight Lbs [kg]	Mtg Type W - Wall F - Floor	Wiring Diagram
			Width	Depth	Height			
15	SK3A0015PK3K	DH1	21.5 [546]	20.13 [511]	22 [559]	240 [109]	F or W/C*	SCD 19
30	SK3A0030PK3K	DH2	25.8 [655]	23.8 [605]	28.8 [732]	370 [168]	F or W/C*	SCD 19
45	SK3A0045PK3K	DH2	25.8 [655]	23.8 [605]	28.8 [732]	430 [195]	F or W/C*	SCD 19
75	SK3A0075PK3K	DH3	28.3 [719]	27 [686]	36 [914]	620 [281]	F (Opt W/C)	SCD 19
112.5	SK3A0112PK3K	DH3	28.3 [719]	27 [686]	36 [914]	840 [381]	F (Opt W/C)	SCD 19
150	SK3A0150PK3K	DH4	31.5 [800]	29.5 [749]	44.5 [1130]	1100 [499]	F	SCD 19
225	SK3A0225PK3K	DH4	31.5 [800]	29.5 [749]	44.5 [1130]	1620 [735]	F	SCD 19
300	SK3A0300PK3K	DH5	38 [965]	34 [864]	52 [1321]	2060 [934]	F	SCD 19
500	SK3A0500PK3K	DH6	49 [1245]	42 [1067]	64 [1626]	3400 [1542]	F	SCD 20
505	SK3A0505PK3K	DH6	49 [1245]	42 [1067]	64 [1626]	3400 [1542]	F	SCD 20
750	SK3A0750PK3K	DH6	49 [1245]	42 [1067]	64 [1626]	4500 [2041]	F	SCD 20
1000	SK3A1000PK3K	DH7	54 [1372]	47 [1194]	72 [1829]	5700 [2585]	F	SCD 10

*W/C: Built-in Wall Ceiling Mounting Opt W/C: Wall Ceiling Mounting Kit "DW3" Available

SELECTION TABLES

HARMONIC MITIGATING TRANSFORMERS



0° Phase Shift, Aluminum Wound, Shielded, Three Phase

480 DELTA PRIMARY VOLTS

208Y/120 SECONDARY VOLTS

60 HZ

kVA	Catalog Number	Case Style	Approx. Dimensions - Inches [mm]			Approx. Weight Lbs [kg]	Mtg Type W - Wall F - Floor	Wiring Diagram
			Width	Depth	Height			
15	SH3T0015KB3S	DH1	21.5 [546]	20.13 [511]	22 [559]	250 [113]	F or W/C*	SCD62
30	SH3T0030KB3S	DH2	25.8 [655]	23.8 [605]	28.8 [732]	380 [172]	F or W/C*	SCD62
45	SH3T0045KB3S	DH2	25.8 [655]	23.8 [605]	28.8 [732]	450 [204]	F or W/C*	SCD62
75	SH3T0075KB3S	DH3	28.3 [719]	27 [686]	36 [914]	650 [295]	F (Opt W/C)	SCD62
112.5	SH3T0112KB3S	DH3	28.3 [719]	27 [686]	36 [914]	880 [399]	F (Opt W/C)	SCD62
150	SH3T0150KB3S	DH4	31.5 [800]	29.5 [749]	44.5 [1130]	1160 [526]	F	SCD62
225	SH3T0225KB3S	DH5	38 [965]	34 [864]	52 [1321]	1720 [780]	F	SCD62
300	SH3T0300KB3S	DH5	38 [965]	34 [864]	52 [1321]	2150 [975]	F	SCD63
500	SH3T0500KB3S	DH6	49 [1245]	42 [1067]	64 [1626]	3600 [1633]	F	SCD63
505	SH3T0505KB3S	DH6	49 [1245]	42 [1067]	64 [1626]	3600 [1633]	F	SCD63
750	SH3T0750KB3S	DH7	54 [1372]	47 [1194]	72 [1829]	4800 [2177]	F	SCD66
1000	SH3T1000KB3S	DH8	60 [1524]	50 [1270]	82 [2083]	6000 [2722]	F	SCD66

600 DELTA PRIMARY VOLTS

208Y/120 SECONDARY VOLTS

60 HZ

kVA	Catalog Number	Case Style	Approx. Dimensions - Inches [mm]			Approx. Weight Lbs [kg]	Mtg Type W - Wall F - Floor	Wiring Diagram
			Width	Depth	Height			
15	SH3T0015PB3S	DH1	21.5 [546]	20.13 [511]	22 [559]	250 [113]	F or W/C*	SCD62
30	SH3T0030PB3S	DH2	25.8 [655]	23.8 [605]	28.8 [732]	380 [172]	F or W/C*	SCD62
45	SH3T0045PB3S	DH2	25.8 [655]	23.8 [605]	28.8 [732]	450 [204]	F or W/C*	SCD62
75	SH3T0075PB3S	DH3	28.3 [719]	27 [686]	36 [914]	650 [295]	F (Opt W/C)	SCD62
112.5	SH3T0112PB3S	DH3	28.3 [719]	27 [686]	36 [914]	880 [399]	F (Opt W/C)	SCD62
150	SH3T0150PB3S	DH4	31.5 [800]	29.5 [749]	44.5 [1130]	1160 [526]	F	SCD62
225	SH3T0225PB3S	DH5	38 [965]	34 [864]	52 [1321]	1720 [780]	F	SCD62
300	SH3T0300PB3S	DH5	38 [965]	34 [864]	52 [1321]	2150 [975]	F	SCD63
500	SH3T0500PB3S	DH6	49 [1245]	42 [1067]	64 [1626]	3600 [1633]	F	SCD63
505	SH3T0505PB3S	DH6	49 [1245]	42 [1067]	64 [1626]	3600 [1633]	F	SCD63
750	SH3T0750PB3S	DH7	54 [1372]	47 [1194]	72 [1829]	4800 [2177]	F	SCD66
1000	SH3T1000PB3S	DH8	60 [1524]	50 [1270]	82 [2083]	6000 [2722]	F	SCD66

0° Phase Shift, Copper Wound, Shielded, Three Phase

480 DELTA PRIMARY VOLTS

208Y/120 SECONDARY VOLTS

60 HZ

kVA	Catalog Number	Case Style	Approx. Dimensions - Inches [mm]			Approx. Weight Lbs [kg]	Mtg Type W - Wall F - Floor	Wiring Diagram
			Width	Depth	Height			
15	SH3T0015KB3K	DH1	21.5 [546]	20.13 [511]	22 [559]	270 [122]	F or W/C*	SCD62
30	SH3T0030KB3K	DH2	25.8 [655]	23.8 [605]	28.8 [732]	410 [186]	F or W/C*	SCD62
45	SH3T0045KB3K	DH2	25.8 [655]	23.8 [605]	28.8 [732]	480 [218]	F or W/C*	SCD62
75	SH3T0075KB3K	DH3	28.3 [719]	27 [686]	36 [914]	700 [318]	F (Opt W/C)	SCD62
112.5	SH3T0112KB3K	DH3	28.3 [719]	27 [686]	36 [914]	940 [426]	F (Opt W/C)	SCD62
150	SH3T0150KB3K	DH4	31.5 [800]	29.5 [749]	44.5 [1130]	1250 [567]	F	SCD62
225	SH3T0225KB3K	DH4	31.5 [800]	29.5 [749]	44.5 [1130]	1850 [839]	F	SCD62
300	SH3T0300KB3K	DH5	38 [965]	34 [864]	52 [1321]	2300 [1043]	F	SCD63
500	SH3T0500KB3K	DH6	49 [1245]	42 [1067]	64 [1626]	3800 [1724]	F	SCD63
505	SH3T0505KB3K	DH6	49 [1245]	42 [1067]	64 [1626]	3800 [1724]	F	SCD63
750	SH3T0750KB3K	DH6	49 [1245]	42 [1067]	64 [1626]	5100 [2313]	F	SCD66
1000	SH3T1000KB3K	DH7	54 [1372]	47 [1194]	72 [1829]	6400 [2903]	F	SCD66

600 DELTA PRIMARY VOLTS

208Y/120 SECONDARY VOLTS

60 HZ

kVA	Catalog Number	Case Style	Approx. Dimensions - Inches [mm]			Approx. Weight Lbs [kg]	Mtg Type W - Wall F - Floor	Wiring Diagram
			Width	Depth	Height			
15	SH3T0015PB3K	DH1	21.5 [546]	20.13 [511]	22 [559]	270 [122]	F or W/C*	SCD62
30	SH3T0030PB3K	DH2	25.8 [655]	23.8 [605]	28.8 [732]	410 [186]	F or W/C*	SCD62
45	SH3T0045PB3K	DH2	25.8 [655]	23.8 [605]	28.8 [732]	480 [218]	F or W/C*	SCD62
75	SH3T0075PB3K	DH3	28.3 [719]	27 [686]	36 [914]	700 [318]	F (Opt W/C)	SCD62
112.5	SH3T0112PB3K	DH3	28.3 [719]	27 [686]	36 [914]	940 [426]	F (Opt W/C)	SCD62
150	SH3T0150PB3K	DH4	31.5 [800]	29.5 [749]	44.5 [1130]	1250 [567]	F	SCD62
225	SH3T0225PB3K	DH4	31.5 [800]	29.5 [749]	44.5 [1130]	1850 [839]	F	SCD62
300	SH3T0300PB3K	DH5	38 [965]	34 [864]	52 [1321]	2300 [1043]	F	SCD63
500	SH3T0500PB3K	DH6	49 [1245]	42 [1067]	64 [1626]	3800 [1724]	F	SCD63
505	SH3T0505PB3K	DH6	49 [1245]	42 [1067]	64 [1626]	3800 [1724]	F	SCD63
750	SH3T0750PB3K	DH6	49 [1245]	42 [1067]	64 [1626]	5100 [2313]	F	SCD66
1000	SH3T1000PB3K	DH7	54 [1372]	47 [1194]	72 [1829]	6400 [2903]	F	SCD66

*W/C: Built-in Wall Ceiling Mounting Opt W/C: Wall Ceiling Mounting Kit "DW3" Available

HP3 Harmonic Mitigating transformers have a standard K13 load profile
Other K load profiles are available by contacting our sales offices.

SELECTION TABLES

HARMONIC MITIGATING TRANSFORMERS



-30° Phase Shift, Aluminum Wound, Shielded, Three Phase

480Y DELTA PRIMARY VOLTS

208Y/120 SECONDARY VOLTS

60 HZ

kVA	Catalog Number	Case Style	Approx. Dimensions - Inches [mm]			Approx. Weight Lbs [kg]	Mtg Type W - Wall F - Floor	Wiring Diagram
			Width	Depth	Height			
15	SH3U0015KB3S	DH1	21.5 [546]	20.13 [511]	22 [559]	260 [118]	F or W/C*	SCD62
30	SH3U0030KB3S	DH2	25.8 [655]	23.8 [605]	28.8 [732]	400 [181]	F or W/C*	SCD62
45	SH3U0045KB3S	DH2	25.8 [655]	23.8 [605]	28.8 [732]	480 [218]	F or W/C*	SCD62
75	SH3U0075KB3S	DH3	28.3 [719]	27 [686]	36 [914]	690 [313]	F (Opt W/C)	SCD62
112.5	SH3U0112KB3S	DH3	28.3 [719]	27 [686]	36 [914]	930 [422]	F (Opt W/C)	SCD62
150	SH3U0150KB3S	DH4	31.5 [800]	29.5 [749]	44.5 [1130]	1220 [553]	F	SCD62
225	SH3U0225KB3S	DH5	38 [965]	34 [864]	52 [1321]	1800 [816]	F	SCD67
300	SH3U0300KB3S	DH5	38 [965]	34 [864]	52 [1321]	2250 [1021]	F	SCD64
500	SH3U0500KB3S	DH6	49 [1245]	42 [1067]	64 [1626]	3800 [1724]	F	SCD64
505	SH3U0505KB3S	DH6	49 [1245]	42 [1067]	64 [1626]	3800 [1724]	F	SCD64
750	SH3U0750KB3S	DH7	54 [1372]	47 [1194]	72 [1829]	5100 [2313]	F	SCD65
1000	SH3U1000KB3S	DH8	60 [1524]	50 [1270]	82 [2083]	6300 [2858]	F	SCD65

600Y DELTA PRIMARY VOLTS

208Y/120 SECONDARY VOLTS

60 HZ

kVA	Catalog Number	Case Style	Approx. Dimensions - Inches [mm]			Approx. Weight Lbs [kg]	Mtg Type W - Wall F - Floor	Wiring Diagram
			Width	Depth	Height			
15	SH3U0015PB3S	DH1	21.5 [546]	20.13 [511]	22 [559]	260 [118]	F or W/C*	SCD62
30	SH3U0030PB3S	DH2	25.8 [655]	23.8 [605]	28.8 [732]	400 [181]	F or W/C*	SCD62
45	SH3U0045PB3S	DH2	25.8 [655]	23.8 [605]	28.8 [732]	480 [218]	F or W/C*	SCD62
75	SH3U0075PB3S	DH3	28.3 [719]	27 [686]	36 [914]	690 [313]	F (Opt W/C)	SCD62
112.5	SH3U0112PB3S	DH3	28.3 [719]	27 [686]	36 [914]	930 [422]	F (Opt W/C)	SCD62
150	SH3U0150PB3S	DH4	31.5 [800]	29.5 [749]	44.5 [1130]	1220 [553]	F	SCD62
225	SH3U0225PB3S	DH5	38 [965]	34 [864]	52 [1321]	1800 [816]	F	SCD67
300	SH3U0300PB3S	DH5	38 [965]	34 [864]	52 [1321]	2250 [1021]	F	SCD64
500	SH3U0500PB3S	DH6	49 [1245]	42 [1067]	64 [1626]	3800 [1724]	F	SCD64
505	SH3U0505PB3S	DH6	49 [1245]	42 [1067]	64 [1626]	3800 [1724]	F	SCD64
750	SH3U0750PB3S	DH7	54 [1372]	47 [1194]	72 [1829]	5100 [2313]	F	SCD65
1000	SH3U1000PB3S	DH8	60 [1524]	50 [1270]	82 [2083]	6300 [2858]	F	SCD65

-30° Phase Shift, Copper Wound, Shielded, Three Phase

480Y DELTA PRIMARY VOLTS

208Y/120 SECONDARY VOLTS

60 HZ

kVA	Catalog Number	Case Style	Approx. Dimensions - Inches [mm]			Approx. Weight Lbs [kg]	Mtg Type W - Wall F - Floor	Wiring Diagram
			Width	Depth	Height			
15	SH3U0015KB3K	DH1	21.5 [546]	20.13 [511]	22 [559]	270 [122]	F or W/C*	SCD62
30	SH3U0030KB3K	DH2	25.8 [655]	23.8 [605]	28.8 [732]	410 [186]	F or W/C*	SCD62
45	SH3U0045KB3K	DH2	25.8 [655]	23.8 [605]	28.8 [732]	480 [218]	F or W/C*	SCD62
75	SH3U0075KB3K	DH3	28.3 [719]	27 [686]	36 [914]	700 [318]	F (Opt W/C)	SCD62
112.5	SH3U0112KB3K	DH3	28.3 [719]	27 [686]	36 [914]	940 [426]	F (Opt W/C)	SCD62
150	SH3U0150KB3K	DH4	31.5 [800]	29.5 [749]	44.5 [1130]	1250 [567]	F	SCD62
225	SH3U0225KB3K	DH4	31.5 [800]	29.5 [749]	44.5 [1130]	1850 [839]	F	SCD67
300	SH3U0300KB3K	DH5	38 [965]	34 [864]	52 [1321]	2300 [1043]	F	SCD64
500	SH3U0500KB3K	DH6	49 [1245]	42 [1067]	64 [1626]	3800 [1724]	F	SCD64
505	SH3U0505KB3K	DH6	49 [1245]	42 [1067]	64 [1626]	3800 [1724]	F	SCD64
750	SH3U0750KB3K	DH6	49 [1245]	42 [1067]	64 [1626]	5100 [2313]	F	SCD65
1000	SH3U1000KB3K	DH7	54 [1372]	47 [1194]	72 [1829]	6400 [2903]	F	SCD65

600Y DELTA PRIMARY VOLTS

208Y/120 SECONDARY VOLTS

60 HZ

kVA	Catalog Number	Case Style	Approx. Dimensions - Inches [mm]			Approx. Weight Lbs [kg]	Mtg Type W - Wall F - Floor	Wiring Diagram
			Width	Depth	Height			
15	SH3U0015PB3K	DH1	21.5 [546]	20.13 [511]	22 [559]	270 [122]	F or W/C*	SCD62
30	SH3U0030PB3K	DH2	25.8 [655]	23.8 [605]	28.8 [732]	410 [186]	F or W/C*	SCD62
45	SH3U0045PB3K	DH2	25.8 [655]	23.8 [605]	28.8 [732]	480 [218]	F or W/C*	SCD62
75	SH3U0075PB3K	DH3	28.3 [719]	27 [686]	36 [914]	700 [318]	F (Opt W/C)	SCD62
112.5	SH3U0112PB3K	DH3	28.3 [719]	27 [686]	36 [914]	940 [426]	F (Opt W/C)	SCD62
150	SH3U0150PB3K	DH4	31.5 [800]	29.5 [749]	44.5 [1130]	1250 [567]	F	SCD62
225	SH3U0225PB3K	DH4	31.5 [800]	29.5 [749]	44.5 [1130]	1850 [839]	F	SCD67
300	SH3U0300PB3K	DH5	38 [965]	34 [864]	52 [1321]	2300 [1043]	F	SCD64
500	SH3U0500PB3K	DH6	49 [1245]	42 [1067]	64 [1626]	3800 [1724]	F	SCD64
505	SH3U0505PB3K	DH6	49 [1245]	42 [1067]	64 [1626]	3800 [1724]	F	SCD64
750	SH3U0750PB3K	DH6	49 [1245]	42 [1067]	64 [1626]	5100 [2313]	F	SCD65
1000	SH3U1000PB3K	DH7	54 [1372]	47 [1194]	72 [1829]	6400 [2903]	F	SCD65

*W/C: Built-in Wall Ceiling Mounting Opt W/C: Wall Ceiling Mounting Kit "DW3" Available

PMS Harmonic Mitigating transformers have a standard K13 load profile Other K load profiles are available by contacting our sales offices.

TYPICAL PERFORMANCE DATA

GENERAL PURPOSE DISTRIBUTION TRANSFORMERS - SINGLE PHASE

Copper

208V TO 600V PRIMARY, 120/240V SECONDARY, 60 HZ, 150°C

kVA	No Load Losses (W)	Full Load Losses* (W)	Impedance	Regulation				% Efficiency at different % of rated load							
				at 35% load		at 100% load		15%	25%	35%	50%	65%	75%	100%	
				pf=1	pf=0.8	pf=1	pf=0.8								
15	60	550	5.2%	0.99%	1.56%	2.89%	4.47%	97.00%	97.75%	97.92%	97.84%	97.61%	97.42%	96.88%	
25	80	910	5.5%	0.99%	1.65%	2.89%	4.73%	97.51%	98.06%	98.14%	98.00%	97.74%	97.53%	96.97%	
37.5	110	1280	6.0%	0.94%	1.78%	2.76%	5.10%	97.70%	98.20%	98.27%	98.13%	97.88%	97.69%	97.16%	
50	130	1650	6.0%	0.91%	1.77%	2.68%	5.08%	97.93%	98.35%	98.39%	98.24%	97.98%	97.79%	97.27%	
75	190	2150	6.0%	0.80%	1.74%	2.38%	4.99%	98.02%	98.45%	98.52%	98.40%	98.19%	98.02%	97.57%	
100	240	2650	6.0%	0.75%	1.72%	2.23%	4.94%	98.12%	98.54%	98.60%	98.50%	98.30%	98.15%	97.73%	
150	380	3300	4.0%	0.63%	1.20%	1.82%	3.43%	98.08%	98.57%	98.68%	98.63%	98.49%	98.36%	98.02%	
167	410	3600	4.0%	0.62%	1.20%	1.81%	3.44%	98.14%	98.60%	98.70%	98.65%	98.51%	98.39%	98.04%	

*Full load losses & full load efficiencies are at a reference temperature of 170°C in accordance with IEEE Standard C57.12.91
Performance data is subject to change without notice.

Aluminum

208V TO 600V PRIMARY, 120/240V SECONDARY, 60 HZ, 150°C

kVA	No Load Losses (W)	Full Load Losses* (W)	Impedance	Regulation				% Efficiency at different % of rated load							
				at 35% load		at 100% load		15%	25%	35%	50%	65%	75%	100%	
				pf=1	pf=0.8	pf=1	pf=0.8								
15	55	650	6.0%	1.17%	1.80%	3.39%	5.14%	97.14%	97.76%	97.84%	97.67%	97.36%	97.12%	96.46%	
25	88	870	6.0%	0.95%	1.78%	2.79%	5.09%	97.33%	97.97%	98.10%	98.00%	97.77%	97.59%	97.07%	
37.5	90	1500	6.0%	1.09%	1.80%	3.17%	5.15%	97.98%	98.30%	98.27%	98.03%	97.69%	97.45%	96.80%	
50	130	1650	6.0%	0.91%	1.77%	2.67%	5.07%	97.93%	98.35%	98.39%	98.24%	97.99%	97.80%	97.27%	
75	170	2300	6.0%	0.85%	1.75%	2.51%	5.03%	98.17%	98.52%	98.54%	98.39%	98.14%	97.96%	97.46%	
100	212	2990	6.0%	0.83%	1.75%	2.47%	5.03%	98.27%	98.59%	98.60%	98.43%	98.19%	98.00%	97.51%	
150	332	3800	6.0%	0.73%	1.72%	2.17%	4.93%	98.25%	98.63%	98.68%	98.57%	98.37%	98.22%	97.80%	
167	352	4250	6.4%	0.74%	1.82%	2.22%	5.23%	98.32%	98.66%	98.70%	98.57%	98.37%	98.21%	97.79%	

*Full load losses & full load efficiencies are at a reference temperature of 170°C in accordance with IEEE Standard C57.12.91
Performance data is subject to change without notice.

TYPICAL PERFORMANCE DATA

GENERAL PURPOSE DISTRIBUTION TRANSFORMERS - THREE PHASE

Copper

600V CLASS

kVA	No Load Losses (W)	Full Load Losses* (W)	Impedance	Regulation				% Efficiency at different % of rated load						
				at 35% load		at 100% load		15%	25%	35%	50%	65%	75%	100%
				pf=1	pf=0.8	pf=1	pf=0.8							
15	64	400	3.9%	0.93%	1.10%	2.68%	3.15%	96.86%	97.68%	97.89%	97.86%	97.67%	97.50%	97.00%
30	96	760	4.0%	0.89%	1.17%	2.57%	3.35%	97.56%	98.13%	98.23%	98.13%	97.90%	97.72%	97.22%
45	135	990	3.7%	0.77%	1.12%	2.22%	3.20%	97.72%	98.28%	98.40%	98.33%	98.15%	98.00%	97.57%
75	194	1470	3.5%	0.69%	1.05%	1.98%	3.02%	98.02%	98.50%	98.60%	98.53%	98.36%	98.22%	97.84%
112.5	275	1850	3.5%	0.58%	1.04%	1.68%	2.97%	98.16%	98.63%	98.74%	98.70%	98.57%	98.46%	98.14%
150	335	2330	3.8%	0.55%	1.12%	1.61%	3.21%	98.31%	98.73%	98.83%	98.79%	98.66%	98.56%	98.25%
225	440	3300	3.8%	0.52%	1.11%	1.52%	3.18%	98.50%	98.86%	98.94%	98.89%	98.76%	98.66%	98.36%
300	560	3930	4.0%	0.47%	1.14%	1.38%	3.26%	98.58%	98.94%	99.02%	98.98%	98.87%	98.78%	98.53%
500	808	5860	4.5%	0.42%	1.23%	1.26%	3.53%	98.76%	99.07%	99.14%	99.10%	99.00%	98.92%	98.68%
505	808	5860	4.5%	0.42%	1.23%	1.26%	3.53%	98.76%	99.07%	99.14%	99.10%	99.00%	98.92%	98.68%
750	980	8710	5.2%	0.42%	1.37%	1.28%	3.96%	98.97%	99.19%	99.23%	99.16%	99.05%	98.97%	98.72%
1000	1250	10400	5.2%	0.38%	1.36%	1.16%	3.91%	99.02%	99.25%	99.28%	99.24%	99.14%	99.07%	98.86%

*Full load losses & full load efficiencies are at a reference temperature of 170°C in accordance with IEEE Standard C57.12.91
Performance data is subject to change without notice.

Aluminum

600V CLASS

kVA	No Load Losses (W)	Full Load Losses* (W)	Impedance	Regulation				% Efficiency at different % of rated load						
				at 35% load		at 100% load		15%	25%	35%	50%	65%	75%	100%
				pf=1	pf=0.8	pf=1	pf=0.8							
15	62	420	4.0%	0.98%	1.12%	2.81%	3.21%	96.92%	97.70%	97.89%	97.82%	97.61%	97.42%	96.89%
30	86	840	4.1%	0.98%	1.19%	2.82%	3.40%	97.72%	98.19%	98.23%	98.06%	97.79%	97.58%	97.00%
45	120	1110	4.5%	0.87%	1.36%	2.51%	3.89%	97.90%	98.35%	98.40%	98.27%	98.03%	97.84%	97.34%
75	190	1490	5.0%	0.71%	1.46%	2.08%	4.18%	98.05%	98.51%	98.60%	98.52%	98.35%	98.20%	97.81%
112.5	226	2260	5.0%	0.71%	1.46%	2.10%	4.18%	98.38%	98.71%	98.74%	98.61%	98.41%	98.26%	97.84%
150	315	2500	5.0%	0.60%	1.42%	1.77%	4.07%	98.38%	98.76%	98.83%	98.76%	98.61%	98.49%	98.16%
225	405	3580	5.4%	0.57%	1.51%	1.72%	4.33%	98.58%	98.89%	98.94%	98.86%	98.70%	98.59%	98.26%
300	540	4040	4.8%	0.48%	1.32%	1.45%	3.79%	98.62%	98.95%	99.02%	98.98%	98.86%	98.77%	98.50%
500	840	5590	5.2%	0.41%	1.37%	1.24%	3.95%	98.73%	99.06%	99.14%	99.11%	99.02%	98.95%	98.73%
505	840	5590	5.2%	0.41%	1.37%	1.24%	3.95%	98.73%	99.06%	99.14%	99.11%	99.02%	98.95%	98.73%
750	1020	8370	5.8%	0.41%	1.50%	1.27%	4.35%	98.94%	99.18%	99.23%	99.18%	99.07%	98.99%	98.76%
1000	1180	11180	5.8%	0.41%	1.50%	1.28%	4.35%	99.05%	99.25%	99.28%	99.21%	99.10%	99.01%	98.78%

*Full load losses & full load efficiencies are at a reference temperature of 170°C in accordance with IEEE Standard C57.12.91
Performance data is subject to change without notice.

TYPICAL IMPEDANCE & INRUSH CURRENT RANGE

GENERAL PURPOSE



Single Phase

VOLTAGE RANGE 120V TO 600V
80°C TO 150°C TEMP. RISE

kVA	Efficiency at 35% of Rated Load, @75°C	Impedance	Peak Inrush Current Multiple of RMS Current
15	97.70%	3.5-6.5%	12 to 15
25	98.00%		
37.5	98.20%		
50	98.31%		
75	98.50%		
100	98.60%	3.5-7%	7 to 10
150	98.68%		
167	98.70%		
250	98.80%		
333	98.90%		

Three Phase

VOLTAGE RANGE 208V TO 600V
80°C TO 150°C TEMP. RISE

kVA	Efficiency at 35% of Rated Load, @75°C	Impedance	Peak Inrush Current Multiple of RMS Current
15	97.89%	1.8-6%	12 to 15
30	98.23%		
45	98.40%		
75	98.60%	2-6.5%	10 to 12
112.5	98.74%		
150	98.83%		
225	98.94%		
300	99.02%		
500	99.14%	4-7%	8 to 10
505	99.14%		
750	99.23%	4-7.5%	8 to 10
1000	99.28%		

TERMINATION DETAILS - TYPE 3R

FOR STANDARD 150°C TEMPERATURE RISE UNITS

Single Phase, Aluminum and Copper Termination - Lugs or Pads

kVA	Voltage									
	120	120/240	208	240	277	347	380	416	480	600
15	Lugs	Lugs	Lugs	Lugs	Lugs	Lugs	Lugs	Lugs	Lugs	Lugs
25	Lugs	Lugs	Lugs	Lugs	Lugs	Lugs	Lugs	Lugs	Lugs	Lugs
37.5	Dia. 1B	Lugs	Lugs	Lugs	Lugs	Lugs	Lugs	Lugs	Lugs	Lugs
50	Dia. 1B	Lugs	Lugs	Lugs	Lugs	Lugs	Lugs	Lugs	Lugs	Lugs
75	Dia. 2	Dia. 1B	Dia. 1B	Dia. 1B	Dia. 1B	Lugs	Lugs	Lugs	Lugs	Lugs
100	Dia. 2	Dia. 1B	Dia. 1B	Dia. 1B	Dia. 1B	Dia. 1B	Lugs	Lugs	Lugs	Lugs
150	Dia. 3	Dia. 2	Dia. 2	Dia. 2	Dia. 1B	Dia. 1B	Dia. 1B	Dia. 1B	Dia. 1B	Dia. 1B
167	Dia. 3	Dia. 2	Dia. 2	Dia. 2	Dia. 2	Dia. 1B	Dia. 1B	Dia. 1B	Dia. 1B	Dia. 1B

Three Phase, Aluminum and Copper Termination - Lugs or Pads

kVA	Voltage								
	208	230	240	277	380	416	480	600	
15	Lugs (Dia.1A)	Lugs	Lugs (Dia. 1A)	Lugs	Lugs (Dia. 1A)	Lugs	Lugs (Dia. 1A)	Lugs (Dia. 1A)	
30	Lugs (Dia.1A)	Lugs	Lugs (Dia. 1A)	Lugs	Lugs (Dia. 1A)	Lugs	Lugs (Dia. 1A)	Lugs (Dia. 1A)	
45	Lugs (Dia. 1A)	Lugs	Lugs (Dia. 1A)	Lugs	Lugs (Dia. 1A)	Lugs	Lugs (Dia. 1A)	Lugs (Dia. 1A)	
75	Lugs (Dia. 1B)	Lugs	Lugs (Dia. 1A)	Lugs	Lugs (Dia. 1A)	Lugs	Lugs (Dia. 1A)	Lugs (Dia. 1A)	
112.5	Lugs (Dia. 1B)	Dia. 1B	Dia. 1B	Lugs	Lugs (Dia. 1A)	Lugs	Lugs (Dia. 1A)	Lugs (Dia. 1A)	
150	Dia. 1B	Dia. 1B	Dia. 1B	Dia. 1B	Lugs (Dia. 1B)	Lugs	Lugs (Dia. 1B)	Lugs	
225	Dia. 2	Dia. 1B	Dia. 1B	Dia. 1B	Dia. 1B	Dia. 1B	Lugs (Dia. 1B)	Lugs	
300	Dia. 2	Dia. 2	Dia. 2	Dia. 2	Dia. 1B	Dia. 1B	Dia. 1B	Dia. 1B	
500	Dia. 3	Dia. 3	Dia. 3	Dia. 3	Dia. 3	Dia. 2	Dia. 2	Dia. 1B	
505	Dia. 3	Dia. 3	Dia. 3	Dia. 3	Dia. 3	Dia. 2	Dia. 2	Dia. 1B	
750	Dia. 3	Dia. 3	Dia. 3	Dia. 3	Dia. 3	Dia. 3	Dia. 3	Dia. 2	
1000	Dia. 4	Dia. 4	Dia. 4	Dia. 4	Dia. 3	Dia. 3	Dia. 3	Dia. 3	

***Lugs only supplied standard on 600V primary to 208Y/120V secondary units. (Excluding K-Factor transformers)
All other voltages supplied standard with Diagram 1B pads.*

Diagram 1

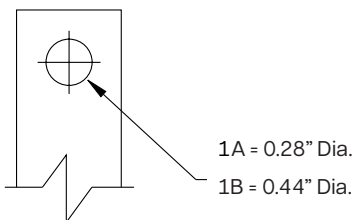

Diagram 2

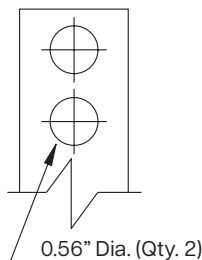

Diagram 3

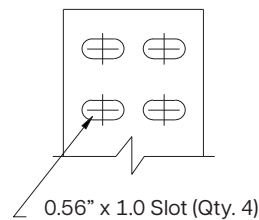
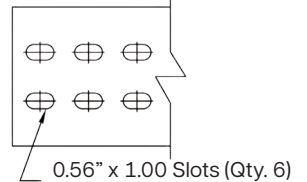
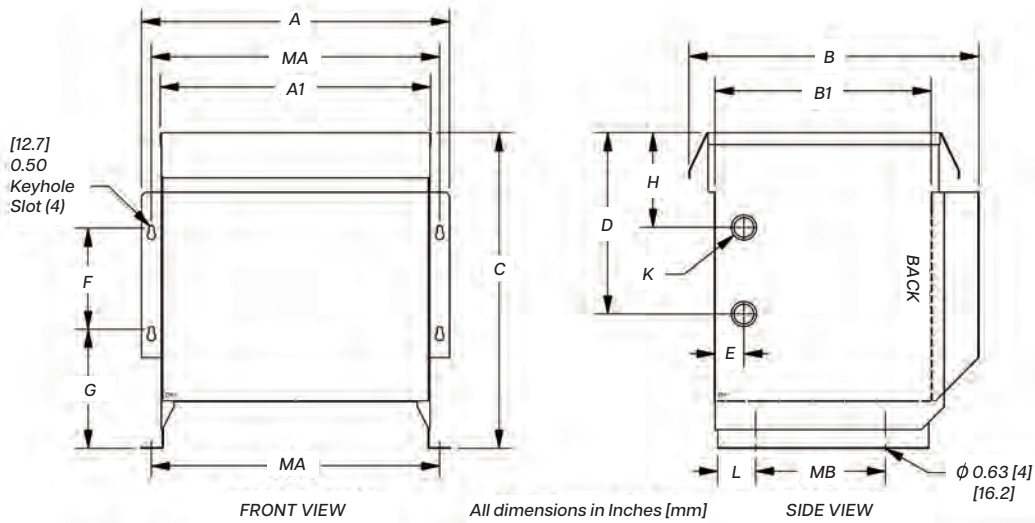

Diagram 4



ENCLOSURE DRAWINGS

DH SERIES



Case Style	Dimensions in Inches [Millimeter]														
	A	A1	B	B1	C	D	E	F	G	H	K	L	MA	MB	
DH1	21.5 [546]	18.8 [477]	20.1 [510]	15 [381]	22 [559]	12.6 [320]	2 [51]	7 [178]	8.3 [211]	6.6 [168]	1.38 X 1.75 K.O. [35 x 44 K.O.]	2.6 [66]	20 [508]	9 [229]	
DH1-1	22.3 [566]	19.8 [503]	23.8 [604]	18 [457]	26.7 [678]	16 [406]	2 [51]	8 [203]	9.2 [234]	8.6 [218]	1.38 X 2.50 K.O. [35 X 63 K.O.]	3.8 [96]	21.1 [536]	9 [229]	
DH2	25.8 [655]	23.3 [592]	23.8 [604]	18 [457]	28.8 [731]	17 [432]	2 [51]	8 [203]	10.3 [262]	8.6 [218]	1.75 X 2.50 K.O. [44 X 63 K.O.]	3.8 [96]	24.6 [625]	9 [229]	

¹ Knockout (K) sizes are actual diameters of knockout, not conduit sizes.

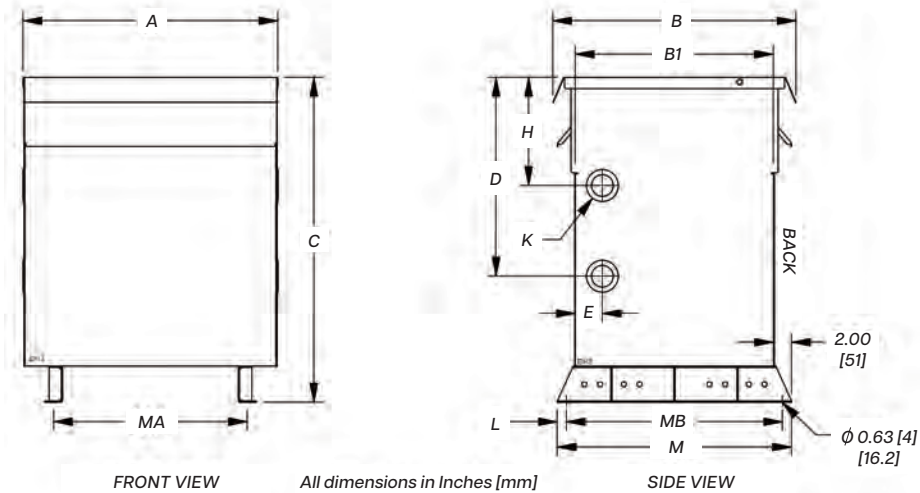

Case Style	Dimensions in Inches [Millimeter]											
	A	B	B1	C	D	E	H	K	L	M	MA	MB
DH3	28.3 [719]	27 [687]	22 [559]	36 [914]	22 [559]	3 [76]	12 [305]	2.00 X 3.00 K.O. [50 X 76 K.O.]	1 [25]	26 [660]	21.5 [546]	24 [610]
DH4	31.5 [800]	29.5 [749]	24.5 [622]	44.5 [1130]	27.5 [698]	3 [76]	14.5 [368]	2.00 X 3.00 K.O. [50 X 76 K.O.]	1 [25]	28.5 [724]	23.5 [597]	26.5 [673]

¹ Knockout (K) sizes are actual diameters of knockout, not conduit sizes.

ENCLOSURE DRAWINGS

DH SERIES

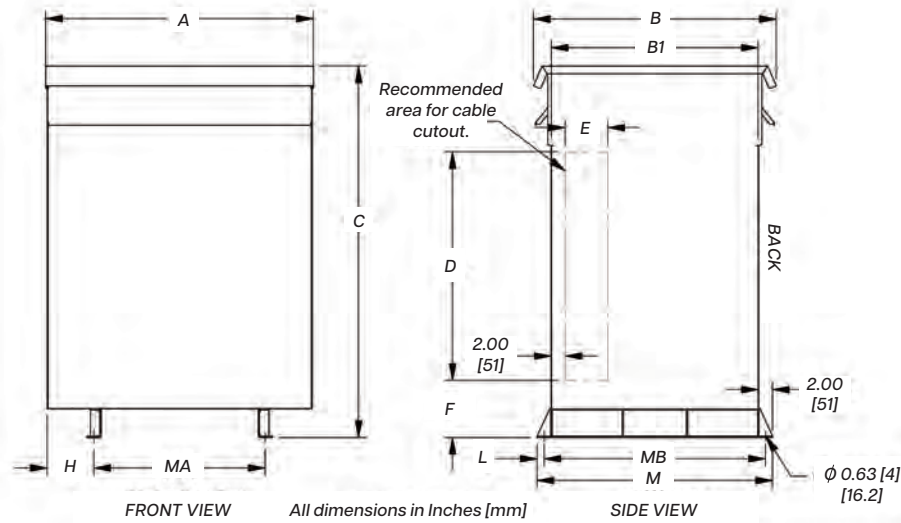

Case Style	Dimensions in Inches [Millimeter]											
	A	B	B1	C	D	E	F	H	L	M	MA	MB
DH5	38 [965]	34 [864]	29 [737]	52 [1321]	32 [813]	6 [152]	8 [203]	6.6 [168]	1 [25]	33 [838]	24 [610]	31 [787]

¹ Knockout (K) sizes are actual diameters of knockout, not conduit sizes.

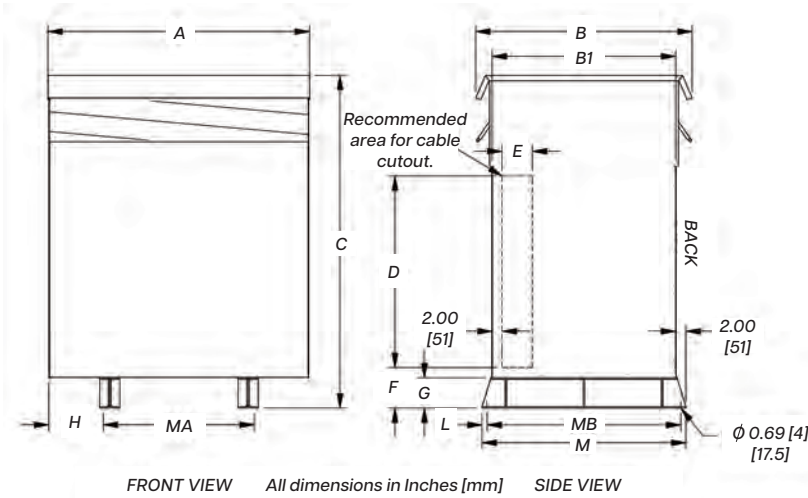

Case Style	Dimensions in Inches [Millimeter]												
	A	B	B1	C	D	E	F	G	H	L	M	MA	MB
DH6	49 [1245]	42 [1067]	35 [889]	64 [1626]	32 [813]	6 [152]	10 [254]	6 [152]	9.3 [236]	1 [25]	39 [991]	30 [762]	37 [940]
DH7	54 [1372]	47 [1194]	40 [1016]	72 [1829]	40 [1016]	8 [203]	10 [254]	6 [152]	8.8 [223]	1 [25]	44 [1117]	36 [914]	42 [1067]
DH8	60 [1524]	50 [1270]	43 [1092]	82 [2083]	50 [1270]	10 [254]	10 [254]	6 [152]	9.8 [249]	1 [25]	47 [1194]	40 [1016]	45 [1143]
DH9	68 [1727]	50 [1270]	43 [1092]	82 [2083]	40 [1016]	10 [254]	10 [254]	6 [152]	11.8 [300]	1 [25]	47 [1194]	44 [1118]	45 [1143]
DH10	78 [1981]	55 [1397]	48 [1219]	86 [2083]	46 [1168]	10 [254]	10 [254]	6 [152]	14.8 [376]	1 [25]	52 [1321]	48 [1219]	50 [1270]

¹ Knockout (K) sizes are actual diameters of knockout, not conduit sizes.

Enclosure Mounting Kits

If wall and/or ceiling mounting is desired for a transformer, optional mounting kits can be ordered separately. These mounting kits are NOT available for all enclosure case styles. Therefore, it is important that you confirm your enclosure case style, then use the selection table to the right to determine if A) a mounting kit is available and B) determine the correct HPS “Mounting Kit” part number that you must order. One kit is required for each transformer.

Note: Some of the mounting kits can be used for both wall and ceiling mount, while others are for wall mounting only. The table indicates which mounting methods are available for each kit. The DW3 wall/ceiling mounting kit also includes a drip plate.

The DW3 wall/ceiling mounting kit is only designed for units up to 1000 pounds (453 kg) maximum.

If it is intended to wall and/or ceiling mount an enclosure that does not have a wall/ceiling mount kit available, considerations must be made to mechanically support the transformer safely and to install per the local building code. A drip plate must be provided beneath the enclosure per UL 1561 and CSA C22.2 No. 47.

DH1DP And DH2DP Wall/Ceiling Mounting Kits

The DH1, DH1-1 and DH2 enclosures are designed with integral wall mounting capabilities. However, when you wall mount them, you must also install the bottom drip plate as shown below. The “MB” dimensions listed in the table below indicate the location for the wall mounting hardware.

For ceiling mounting of the DH1, DH1-1 and DH2, refer to the “MA” dimensions listed in the table below and hang the enclosure using appropriate sized ceiling hanger rods. However, you must be sure to install the bottom drip plate to the bottom of the enclosure, then bring the hanger rod down through both the enclosure bottom mounting holes, through the drip plate mounting holes, and install mounting hardware.

Note: Do not ceiling mount either the DH1, DH1-1 and DH2 enclosures without installing the bottom drip plate. All mounting hardware should be rated Grade 8 or higher.

Enclosure Case Style	Wall Mount Available	Ceiling Mount Available	HPS Mounting Kit P/N
DH1	Yes	Yes	DH1DP
DH1-1	Yes	Yes	DH1-IDP
DH2	Yes	Yes	DH2DP
DH3	Yes	Yes	DW3
DH4	No	No	N/A
DH5	No	No	N/A
DH6	No	No	N/A
DH7	No	No	N/A
DH8	No	No	N/A

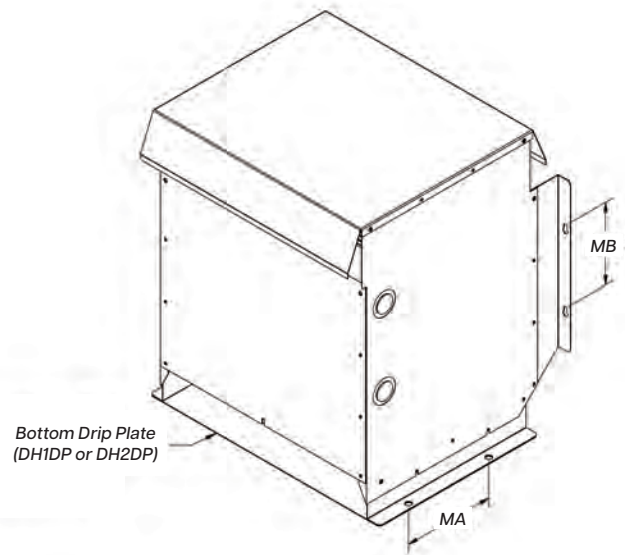

Mounting Kit P/N	Enclosure Style	MA Dimension Inches [mm]	MB Dimension Inches [mm]
DH1DP	DH1	9.00 [229]	7.00 [178]
DH1-IDP	DH1-1	9.00 [229]	8.00 [203]
DH2DP	DH2	9.00 [229]	8.00 [203]

ENCLOSURE WALL MOUNTING DIMENSIONS

DW3 Wall Mounting Kit Dimensions

The following drawings detail the wall mounting dimensions required and method by which the DW3 kit are installed on their respective DH3 enclosures. The DW3 wall mounting kit also includes a drip plate.

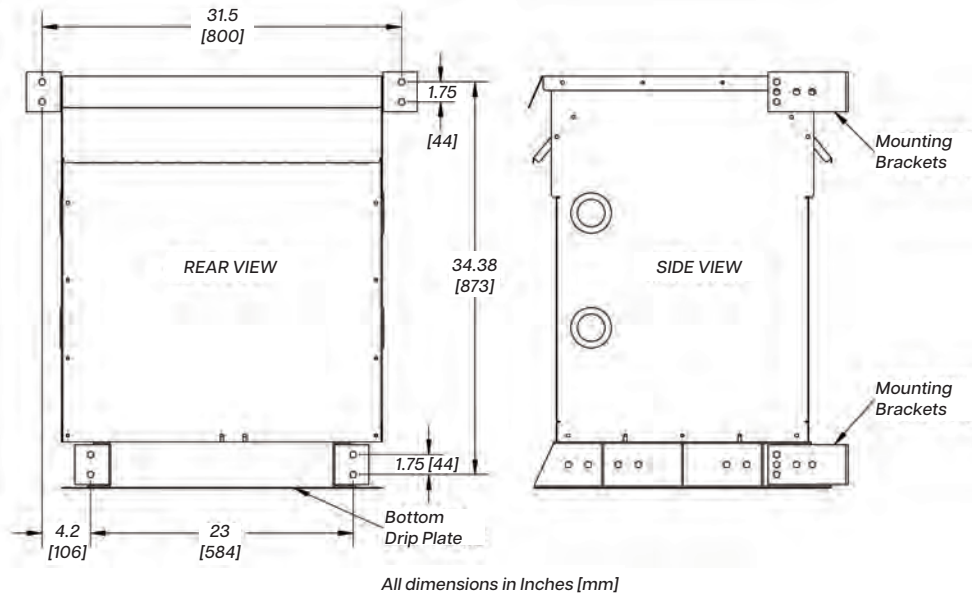

DW3 Wall Mount Dimensions

DW3 Ceiling Mounting Kit Dimensions

The following drawings detail the ceiling mounting dimensions required and method by which the DW3 kit are installed on the DH3 enclosure.

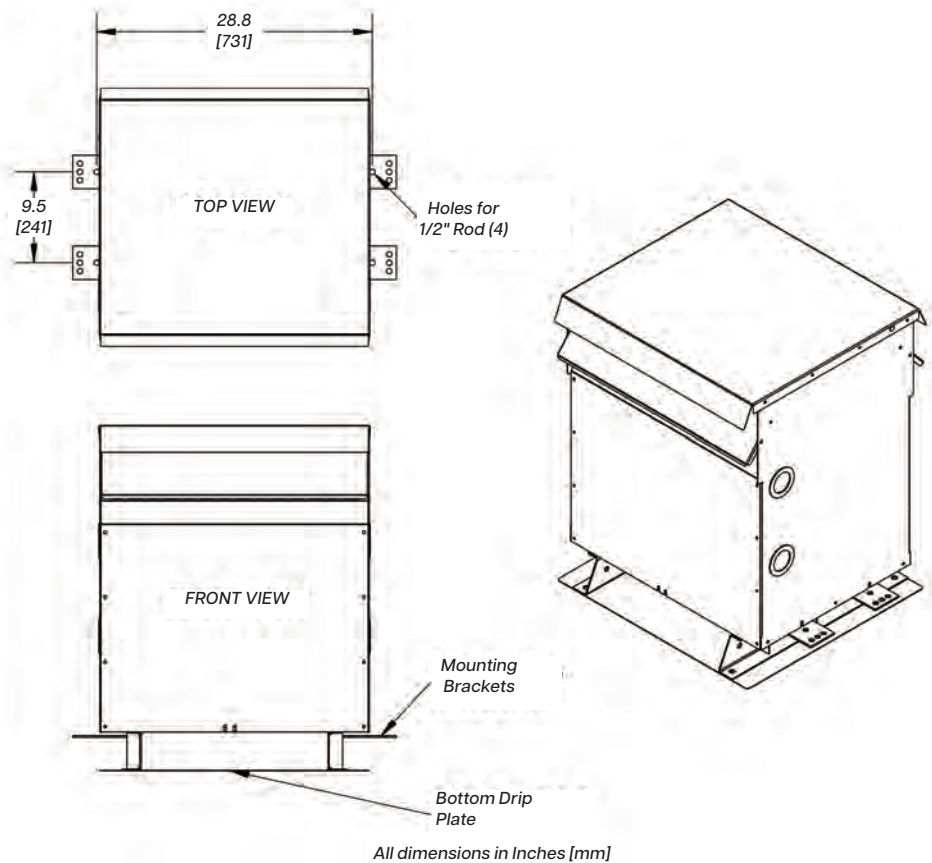

DW3 Ceiling Mount - Mounting Dimensions for DH3 Enclosures

ANTI-VIBRATION PAD & VIBRATION ISOLATOR KITS

Anti-Vibration Pad and Vibration Isolator Kits

All standard transformers come with installed internal vibration absorbing pads to minimize noise during operation. Optional external “anti-vibration” pad and “vibration isolator” (for higher noise dampening) kits can be used to reduce operating noise even further. All pads are resistant to industrial contaminants like oil, acids and alkalines.

ANTI-VIBRATION PAD KITS

Part No.	Case Style	Description
PD1	DH1-DH5	Set of four (4) rubber anti-vibration pads which replace the standard steel enclosure washers.
PD2	DH6-DH8	



All anti-vibration pad kits and vibration isolator kits contain a set of four (4) pads or isolators. Therefore only one kit is required per transformer.

VIBRATION ISOLATOR KITS

Part No.	Transformer Weight Lbs [kg]	Description
NMP1	Up to 340 lbs [154]	Set of four (4) molded neoprene and steel plate assemblies that virtually eliminate vibration noise between the transformer and the mounting surface.
NMP2	341 to 680 lbs [155 to 608]	
NMP3	681 to 1040 lbs [309 to 472]	
NMP4	1041 to 1740 lbs [472 to 789]	
NMP5	1741 to 2330 lbs [790 to 1057]	
NMP6	2331 to 3450 lbs [1057 to 1565]	
NMP7	3451 to 4690 lbs [1565 to 2127]	



All anti-vibration pad kits and vibration isolator kits contain a set of four (4) pads or isolators. Therefore only one kit is required per transformer.

ENCLOSURE SPARE PARTS

Minimum Order Size applies to enclosure spare parts.

Due to technical and certification compliance reasons only selected enclosure parts are offered as spare parts (as per table). For front panel replacements please contact your HPS sales office.



HPS Part No.	Part Description	Qty per Package
DH1001	DH1 Enclosure Top Panel	1
DH1002	DH1 Enclosure Left Side Panel	1
DH1003	DH1 Enclosure Right Side Panel	1
DH1-1001	DH1-1 Enclosure Top Panel	1
DH1-1002	DH1-1 Enclosure Left Side Panel	1
DH1-1003	DH1-1 Enclosure Right Side Panel	1
DH2001	DH2 Enclosure Top Panel	1
DH2002	DH2 Enclosure Left Side Panel	1
DH2003	DH2 Enclosure Right Side Panel	1
DH3001	DH3 Enclosure Top Panel	1
DH3002	DH3 Enclosure Left Side Panel	1
DH3003	DH3 Enclosure Right Side Panel	1
DH3005	DH3 Enclosure Back Panel	1
DH3007	DH3 Enclosure Drip-Shield	1
DH4001	DH4 Enclosure Top Panel	1
DH4002	DH4 Enclosure Left Side Panel	1
DH4003	DH4 Enclosure Right Side Panel	1
DH4005	DH4 Enclosure Back Panel	1
DH4007	DH4 Enclosure Drip-Shield	1
DH5001	DH5 Enclosure Top Panel	1
DH5002	DH5 Enclosure Left Side Panel	1
DH5003	DH5 Enclosure Right Side Panel	1
DH5005	DH5 Enclosure Back Panel	1
DH5007	DH5 Drip-Shield	1
DH5008	DH5 Enclosure Jacking Angle - Front	1
DH5009	DH5 Enclosure Jacking Angle - Back	1

TOUCH-UP PAINT

Please verify part number with HPS Customer Service to determine which shade of paint to use.

Mexico Built Products: **PNT10098**

Canada/US Built Products: **PNT10099**

ELECTRICAL SCHEMATICS & CONNECTION DRAWINGS

SCD 2

Schematic		Connections			
	Primary Volts		Connect lines to	Inter-connect	
	504	440	218	H1, H2	1-2
	492	416	213	H1, H2	2-3
	480	400	208	H1, H2	3-4
	468	380	203	H1, H2	4-5
	456	220	198	H1, H2	5-6
	444	208	192	H1, H2	6-7
	432	200	187	H1, H2	7-8
	240	190		H1, H2	H1-2, H2-1
	228			H1, H2	H1-4, H2-3
	216			H1, H2	H1-6, H2-5
				H1, H2	H1-8, H2-7
	Secondary Volts		Connect lines to		Inter-connect
	240		X1, X4		X2-X3
120		X1, X2		X2-X4, X1-X3	
120/240		X1, X2, X4		X2-X3	

SCD 6

Schematic		Connections					
	% Voltage	Primary Volts			Connect lines to	Inter-connect	
	105.0%	218	291	437	630	H1, H2	1-2
	102.5%	213	284	426	615	H1, H2	2-3
	100.0%	208	277	416	600	H1, H2	3-4
	97.5%	203	270	406	585	H1, H2	4-5
	95.0%	198	263	395	570	H1, H2	5-6
	Secondary Volts		Connect lines to		Inter-connect		
240		X1, X4		X2-X3			
120		X1, X2		X2-X4, X1-X3			
120/240		X1, X2, X4		X2-X3			

SCD 7A

Schematic		Connections									
	% Voltage	Primary Volts								Connect lines to	Inter-connect
	105.0%	218	242	252	437	483	504	604	630	H1, H2, H3	1
	100.0%	208	230	240	416	460	480	575	600	H1, H2, H3	2
	95.0%	198	219	228	395	437	456	546	570	H1, H2, H3	3
Secondary Volts		Connect lines to								Inter-connect	
		208	230	240	380	416	460	480	600	X1, X2, X3	
		120	133	139	220	240	265	277	347	X1, X0 X2, X0 X3, X0	

SCD 7B

Schematic		Connections									
	% Voltage	Primary Volts								Connect lines to	Inter-connect
	100.0%	208 480								H1, H2, H3	1
	95.0%	198 456								H1, H2, H3	2
	90.0%	187 432								H1, H2, H3	3
Secondary Volts		Connect lines to								Inter-connect	
		208	230	240	380	416	460	480	600	X1, X2, X3	
		120	133	139	220	240	265	277	347	X1, X0 X2, X0 X3, X0	

Tap arrangements shown are for catalog products only. May not be applicable for other products.

SCD 8

Schematic		Connections									
	% Voltage	Primary Volts							Connect lines to	Inter-connect	
	105.0%	218	242	252	437	483	504	604	630	H1, H2, H3	1-2
	100.0%	208	230	240	416	460	480	575	600	H1, H2, H3	2-3
	95.0%	198	219	228	395	437	456	546	570	H1, H2, H3	3-4
	Secondary Volts									Connect lines to	Inter-connect
	208	230	240	380	416	460	480	600	X1, X2, X3		
	120	133	139	220	240	265	277	347	X1, X0	X2, X0	X3, X0

SCD 10

Schematic		Connections									
	% Voltage	Primary Volts							Connect lines to	Inter-connect	
	105.0%	218	242	252	437	483	504	604	630	H1, H2, H3	1-2
	102.5%	213	236	246	426	472	492	589	615	H1, H2, H3	2-3
	100.0%	208	230	240	416	460	480	575	600	H1, H2, H3	3-4
	97.5%	203	224	234	406	449	468	561	585	H1, H2, H3	4-5
	95.0%	198	219	228	395	437	456	546	570	H1, H2, H3	5-6
Secondary Volts									Connect lines to	Inter-connect	
	208	380	416	480	600				X1, X2, X3		
	120	220	240	277	347	X1, X0	X2, X0	X3, X0			

SCD 17

Schematic		Connections			
	% Voltage	Primary Volts	Connect lines to	Inter-connect	
	105.0%	252	H1, H2	1-H2, 2-H3, H1-H3, H2-H4	
	100.0%	240	H1, H2	3-H2, 4-H3, H1-H3, H2-H4	
	95.0%	228	H1, H2	5-H2, 6-H3, H1-H3, H2-H4	
	90.0%	216	H1, H2	7-H2, 8-H3, H1-H3, H2-H4	
	105.0%	504	H1, H4	1-H2, 2-H3, H2-H3	
	102.5%	492	H1, H4	3-H2, 2-H3, H2-H3	
	100.0%	480	H1, H4	3-H2, 4-H3, H2-H3	
	97.5%	468	H1, H4	5-H2, 4-H3, H2-H3	
	95.0%	456	H1, H4	5-H2, 6-H3, H2-H3	
	92.5%	444	H1, H4	7-H2, 6-H3, H2-H3	
	90.0%	432	H1, H4	7-H2, 8-H3, H2-H3	
Secondary Volts		Connect lines to		Inter-connect	
	240	X1, X4		X2-X3	
	120	X1, X2		X2-X4, X1-X3	
	120/240	X1, X2, X4		X2-X3	

Tap arrangements shown are for catalog products only. May not be applicable for other products.

ELECTRICAL SCHEMATICS & CONNECTION DRAWINGS

SCD 19

Schematic		Connections					
		% Voltage	Primary Volts		Connect lines to	Inter-connect	
	105.0%	218	252	504	630	H1, H2, H3	1
	102.5%	213	246	492	615	H1, H2, H3	2
	100.0%	208	240	480	600	H1, H2, H3	3
	97.5%	203	234	468	585	H1, H2, H3	4
	95.0%	198	228	456	570	H1, H2, H3	5
	92.5%	193	222	444	556	H1, H2, H3	6
	90.0%	188	216	432	542	H1, H2, H3	7
			Secondary Volts		Connect lines to	Inter-connect	
			208	480	X1, X2, X3		
			120	277	X1, X0	X2, X0 X3, X0	

SCD 20

Schematic		Connections				
		% Voltage	Primary Volts		Connect lines to	Inter-connect
	105.0%	218	504	630	H1, H2, H3	1-2
	102.5%	213	492	615	H1, H2, H3	2-3
	100.0%	208	480	600	H1, H2, H3	3-4
	97.5%	203	468	585	H1, H2, H3	4-5
	95.0%	198	456	570	H1, H2, H3	5-6
	92.5%	193	444	556	H1, H2, H3	6-7
	90.0%	188	432	542	H1, H2, H3	7-8
			Secondary Volts		Connect lines to	Inter-connect
			208	480	X1, X2, X3	
			120	277	X1, X0	X2, X0 X3, X0

SCD 21

Schematic		Connections				
		% Voltage	Primary Volts		Connect lines to	Inter-connect
	105.0%	504			H1, H2, H3	1
	102.5%	492			H1, H2, H3	2
	100.0%	480			H1, H2, H3	3
	97.5%	468			H1, H2, H3	4
	95.0%	456			H1, H2, H3	5
	92.5%	444			H1, H2, H3	6
	90.0%	432			H1, H2, H3	7
			Secondary Volts		Connect lines to	Inter-connect
			240			X1, X2, X3
			120			X1, X6 X3, X6

Tap arrangements shown are for catalog products only. May not be applicable for other products.

SCD 22

Schematic		Connections				
		% Voltage	Primary Volts		Connect lines to	Inter-connect
		105.0%	504		H1, H2, H3	1-2
102.5%	492		H1, H2, H3	2-3		
100.0%	480		H1, H2, H3	3-4		
97.5%	468		H1, H2, H3	4-5		
95.0%	456		H1, H2, H3	5-6		
92.5%	444		H1, H2, H3	6-7		
90.0%	432		H1, H2, H3	7-8		
		Secondary Volts		Connect lines to	Inter-connect	
		240		X1, X2, X3		
		120		X1, X6 X3, X6		

SCD 23A

Schematic		Connections				
		% Voltage	Primary Volts		Connect lines to	Inter-connect
		105.0%	218	252	X1, X2, X3	1-2
100.0%	208	240	X1, X2, X3	2-3		
95.0%	198	228	X1, X2, X3	3-4		
		Secondary Volts		Connect lines to	Inter-connect	
		480		H1, H2, H3		
		277		H1, H0 H2, H0 H3, H0		

SCD 23B

Schematic		Connections				
		% Voltage	Primary Volts		Connect lines to	Inter-connect
		100.0%	208	240	X1, X2, X3	1-2
95.0%	198	228	X1, X2, X3	2-3		
90.0%	188	216	X1, X2, X3	3-4		
		Secondary Volts		Connect lines to	Inter-connect	
		230	260	460	480	H1, H2, H3
		133	139	265	277	H1, H0 H2, H0 H3, H0

SCD 29

Schematic		Connections				
		% Voltage	Primary Volts		Connect lines to	Inter-connect
		105.0%	630	504	H1, H2, H3	1-2
102.5%	615	492	H1, H2, H3	2-3		
100.0%	600	480	H1, H2, H3	3-4		
97.5%	585	468	H1, H2, H3	4-5		
95.0%	570	456	H1, H2, H3	5-6		
		Secondary Volts		Connect lines to	Inter-connect	
		240		X1, X2, X3		

Tap arrangements shown are for catalog products only. May not be applicable for other products.

ELECTRICAL SCHEMATICS & CONNECTION DRAWINGS

SCD 30

Schematic		Connections		
	Primary Volts	Connect lines to	Inter-connect	
	440	H1, H4	1-H2, 2-H3, H2-H3	
	416	H1, H4	3-H2, 4-H3, H2-H3	
	400	H1, H4	5-H2, 6-H3, H2-H3	
	380	H1, H4	7-H2, 8-H3, H2-H3	
	220	H1, H2	1-H2, 2-H3, H1-H3, H2-H4	
	208	H1, H2	3-H2, 4-H3, H1-H3, H2-H4	
	200	H1, H2	5-H2, 6-H3, H1-H3, H2-H4	
	190	H1, H2	7-H2, 8-H3, H1-H3, H2-H4	
	Secondary Volts	Connect lines to	Inter-connect	
	240	X1, X4	X2-X3	
	120	X1, X2	X2-X4, X1-X3	
120/240	X1, X2, X4	X2-X3		

SCD 34

Schematic		Connections		
	% Voltage	Primary Volts	Connect lines to	Inter-connect
	100.0%	240	H1, H4	1-H2, 2-H3, H1-H3, H2-H4
	90.0%	216	H1, H4	3-H2, 4-H3, H1-H3, H2-H4
	100.0%	480	H1, H4	1-H2, 2-H3, H2-H3
	95.0%	456	H1, H4	2-H3, 3-H2, H2-H3
	90.0%	432	H1, H4	3-H2, 4-H3, H2-H3
	Secondary Volts	Connect lines to	Inter-connect	
	240	X1, X4	X2-X3	
	120/240	X1, X2, X4	X2-X3	
	120	X1, X2	X2-X4, X1-X3	

SCD 39

Schematic		Connections		
	% Voltage	Primary Volts	Connect lines to	Inter-connect
	105.0%	437 630	H1, H2	H2-1
	102.5%	426 615	H1, H2	H2-2
	100.0%	416 600	H1, H2	H2-3
	97.5%	406 585	H1, H2	H2-4
	95.0%	395 570	H1, H2	H2-5
	Secondary Volts	Connect lines to	Inter-connect	
	240	X1, X4	X2-X3	
	120	X1, X2	X2-X4, X1-X3	
	120/240	X1, X2, X4	X2-X3	

Tap arrangements shown are for catalog products only. May not be applicable for other products.

SCD 52

Schematic		Connections			
	% Voltage	Primary Volts	Connect lines to		Inter-connect
	105.0%	504	H1, H2, H3		1
	102.5%	492	H1, H2, H3		2
	100.0%	480	H1, H2, H3		3
	97.5%	468	H1, H2, H3		4
	95.0%	456	H1, H2, H3		5
	92.5%	444	H1, H2, H3		6
	90.0%	432	H1, H2, H3		7
	Secondary Volts		Connect lines to		Inter-connect
	107.5%	430	X1, X2, X3		X1-A, X2-A, X3-A
	104.0%	416	X1, X2, X3		X1-B, X2-B, X3-B
	100.0%	400	X1, X2, X3		X1-C, X2-C, X3-C
	95.0%	380	X1, X2, X3		X1-D, X2-D, X3-D
		248	X1, X0	X2, X0	X3, X0
	240	X1, X0	X2, X0	X3, X0	X1-B, X2-B, X3-B
	231	X1, X0	X2, X0	X3, X0	X1-C, X2-C, X3-C
	219	X1, X0	X2, X0	X3, X0	X1-D, X2-D, X3-D

SCD 53

Schematic		Connections			
	% Voltage	Primary Volts	Connect lines to		Inter-connect
	105.0%	218 252	X1, X2, X3		1
	102.5%	213 246	X1, X2, X3		2
	100.0%	208 240	X1, X2, X3		3
	97.5%	203 234	X1, X2, X3		4
	95.0%	198 228	X1, X2, X3		5
	92.5%	192 222	X1, X2, X3		6
	90.0%	187 216	X1, X2, X3		7
	Secondary Volts		Connect lines to		Inter-connect
		480	H1, H2, H3		
		277	H1, H0	H2, H0	H3, H0

SCD 54

Schematic		Connections			
	% Voltage	Primary Volts	Connect lines to		Inter-connect
	105.0%	630	H1, H2, H3		1
	102.5%	615	H1, H2, H3		2
	100.0%	600	H1, H2, H3		3
	97.5%	585	H1, H2, H3		4
	95.0%	570	H1, H2, H3		5
	92.5%	555	H1, H2, H3		6
	90.0%	540	H1, H2, H3		7
	Secondary Volts		Connect lines to		Inter-connect
		240	X1, X2, X3		

Tap arrangements shown are for catalog products only. May not be applicable for other products.

ELECTRICAL SCHEMATICS & CONNECTION DRAWINGS

SCD 56

Schematic		Connections			
	% Voltage	Primary Volts		Connect lines to	Inter-connect
	105.0%	218	252	X1, X2, X3	1
	100.0%	208	240	X1, X2, X3	2
	95.0%	198	228	X1, X2, X3	3
	Secondary Volts		Connect lines to		Inter-connect
		480		H1, H2, H3	
		277		H1, HO H2, HO H3, HO	

SCD 59

Schematic		Connections			
	% Voltage	Primary Volts		Connect lines to	Inter-connect
	105.0%	504		H1, H2, H3	1-2
	102.5%	492		H1, H2, H3	2-3
	100.0%	480		H1, H2, H3	3-4
	97.5%	468		H1, H2, H3	4-5
	95.0%	456		H1, H2, H3	5-6
Secondary Volts		Connect lines to		Inter-connect	
		240		X1, X2, X3	
		120		X1, X6 X3, X6	

SCD 60

Schematic		Connections				
	% Voltage	Primary Volts		Connect lines to	Inter-connect	
	100.0%	208 or 240		H1, H2, H3		
	Secondary Volts		Connect lines to		Inter-connect	
			208		X1, X2, X3	
			120		X1, X0 X2, X0 X3, X0	

Tap arrangements shown are for catalog products only. May not be applicable for other products.

SCD 61

Schematic		Connections			
	% Voltage	Primary Volts		Connect lines to	Inter-connect
	100.0%	208 or 240		X1, X2, X3	
		Secondary Volts		Connect lines to	Inter-connect
		208		H1, H2, H3	
		277		H1, H0 H2, H0 H3, H0	

SCD 62

Schematic		Connections			
	% Voltage	Primary Volts		Connect lines to	Inter-connect
	105.0%	630	504	H1, H2, H3	1
	102.5%	615	492	H1, H2, H3	2
	100.0%	600	480	H1, H2, H3	3
	97.5%	585	468	H1, H2, H3	4
	95.0%	570	456	H1, H2, H3	5
	92.5%	555	444	H1, H2, H3	6
	90.0%	540	432	H1, H2, H3	7
		Secondary Volts		Connect lines to	Inter-connect
		600	480	208	X1, X2, X3
	346	277	120	X0-X1, X0-X2, X0-X3	

SCD 63

Schematic		Connections			
	% Voltage	Primary Volts		Connect lines to	Inter-connect
	105.0%	630	504	H1, H2, H3	1-2
	102.5%	615	492	H1, H2, H3	2-3
	100.0%	600	480	H1, H2, H3	3-4
	97.5%	585	468	H1, H2, H3	4-5
	95.0%	570	456	H1, H2, H3	5-6
	92.5%	555	444	H1, H2, H3	6-7
	90.0%	540	432	H1, H2, H3	7-8
		Secondary Volts		Connect lines to	Inter-connect
		600	480	208	X1, X2, X3
	346	277	120	X0-X1, X0-X2 X0-X3	

Tap arrangements shown are for catalog products only. May not be applicable for other products.

ELECTRICAL SCHEMATICS & CONNECTION DRAWINGS

SCD 64

Schematic		Connections			
	% Voltage	Primary Volts		Connect lines to	Inter-connect
	104.2%	625	500	H1, H2, H3	1
	100.0%	600	480	H1, H2, H3	2
	95.8%	575	468	H1, H2, H3	3
		Secondary Volts		Connect lines to	Inter-connect
		600	480	208	X1, X2, X3
		346	277	120	X0-X1, X0-X2 X0-X3

SCD 65

Schematic		Connections			
	% Voltage	Primary Volts		Connect lines to	Inter-connect
	106.2%	637	510	H1, H2, H3	1-2
	100.0%	600	480	H1, H2, H3	2-3
	93.8%	563	450	H1, H2, H3	3-4
		Secondary Volts		Connect lines to	Inter-connect
		600	480	208	X1, X2, X3
		346	277	120	X0-X1, X0-X2 X0-X3

SCD 66

Schematic		Connections			
	% Voltage	Primary Volts		Connect lines to	Inter-connect
	107.0%	642	514	H1, H2, H3	1-2
	103.5%	621	497	H1, H2, H3	2-3
	100.0%	600	480	H1, H2, H3	3-4
	96.5%	579	463	H1, H2, H3	4-5
	93.0%	558	446	H1, H2, H3	5-6
		Secondary Volts		Connect lines to	Inter-connect
		600	480	208	X1, X2, X3
		346	277	120	X0-X1, X0-X2 X0-X3

Tap arrangements shown are for catalog products only. May not be applicable for other products.

SCD 67

Schematic		Connections				
<p style="text-align: center;">HARMONIC MITIGATING TRANSFORMER</p>	% Voltage	Primary Volts		Connect lines to	Inter-connect	
	107.0%	630	504	H1, H2, H3	1	
	103.5%	615	492	H1, H2, H3	2	
	100.0%	600	480	H1, H2, H3	3	
	96.5%	585	468	H1, H2, H3	4	
	93.0%	570	456	H1, H2, H3	5	
			Secondary Volts		Connect lines to	Inter-connect
		600	480	208	X1, X2, X3	
		346	277	120	X0-X1, X0-X2, X0-X3	

SCD 68

Schematic		Connections				
	% Voltage	Primary Volts		Connect lines to	Inter-connect	
	105.0%	218	291	H1, H2	H2-1	
	100.0%	208	277	H1, H2	H2-2	
	95.0%	198	263	H1, H2	H2-3	
			Secondary Volts		Connect lines to	Inter-connect
			240		X1, X4	X2-X3
			120		X1, X2	X2-X4, X1-X3
			120/240		X1, X2, X4	X2-X3

SCD 69

Schematic		Connections				
	% Voltage	Primary Volts		Connect lines to	Inter-connect	
	105.0%	504		H1, H2	H2-1	
	102.5%	492		H1, H2	H2-2	
	100.0%	480		H1, H2	H2-3	
	97.5%	468		H1, H2	H2-4	
	95.0%	456		H1, H2	H2-5	
	92.5%	444		H1, H3	H2-6	
	90.0%	432		H1, H4	H2-7	
			Secondary Volts		Connect lines to	Inter-connect
			240		X1, X4	X2-X3
		120		X1, X2	X2-X4, X1-X3	
		120/240		X1, X2, X4	X2-X3	

Tap arrangements shown are for catalog products only. May not be applicable for other products.

ELECTRICAL SCHEMATICS & CONNECTION DRAWINGS

SCD 70

Schematic	Connections			
	% Voltage	Primary Volts	Connect lines to	Inter-connect
	105.0%	504	H1, H2, H3	1-2
	102.5%	492	H1, H2, H3	2-3
	100.0%	480	H1, H2, H3	3-4
	97.5%	468	H1, H2, H3	4-5
	95.0%	456	H1, H2, H3	5-6
	92.5%	444	H1, H2, H3	6-7
	90.0%	432	H1, H2, H3	7-8
	Secondary Volts		Connect lines to	Inter-connect
	107.5%	430	X1, X2, X3	A
	104.0%	416	X1, X2, X3	B
	100.0%	400	X1, X2, X3	C
	95.0%	380	X1, X2, X3	D
		248	X1,XO X2,XO X3,XO	A
		240	X1,XO X2,XO X3,XO	B
		231	X1,XO X2,XO X3,XO	C
	219	X1,XO X2,XO X3,XO	D	

Tap arrangements shown are for catalog products only. May not be applicable for other products.



CANADA

Hammond Power Solutions

595 Southgate Drive
Guelph, Ontario N1G 3W6
Tel: (519) 822-2441 | Fax: (519) 822-9701
Toll Free: 1-888-798-8882

sales@hammondpowersolutions.com



UNITED STATES

Hammond Power Solutions

1100 Lake Street
Baraboo, Wisconsin 53913-2866
Tel: (608) 356-3921 | Fax: (608) 355-7623
Toll Free: 1-866-705-4684

sales@hammondpowersolutions.com



MEXICO

Hammond Power Solutions Latin America S.

Av. No. 800,
Parque Industrial Guadalupe
Guadalupe, NL, Mexico, C.P. 67190.
Tel: (819) 690-8000

sales@hammondpowersolutions.com



ASIA

Hammond Power Solutions Pvt. Ltd.

Plot No 6A, Phase -1, IDA,
Pashamylaram, Patancheru (M)
Sangareddy, 502 307, India
Tel: +91-994-995-0009

marketing-india@hammondpowersolutions.com

EMEA (SALES OFFICE)

Hammond Power Solutions SpA

Tel: +49 (152) 08800468

sales-emea@hammondpowersolutions.com



hammondpowersolutions.com



SENTSP-BBH2-EN
March 2025