

HPS TITAN™ SERIES

Encapsulated Transformers
For Hazardous Locations



HPS Titan Series Encapsulated Transformers

HPS Titan series encapsulated transformers offer an innovative design with technological improvements for industrial and hazardous applications.

The transformer core and coil is completely encapsulated in epoxy and silica, providing excellent protection from airborne contaminants and prevents the ingress of moisture.

HPS Titan series three phase design has a removable hinged door and factory installed grounding lugs, reducing installation time and money.



Applications



Petrochemical



Marine



Industrial



Oil & Gas



Mining



Wastewater

Approvals

- ANSI/ISA 12.12.10 - File No. E258346 (Class 1, Division 2, Groups A, B, C, D and Class 1, Zone 2, Group IIC, T3 Hazardous Locations) - T3C/T3A Temperature Classification
- UL 5085-1 and UL5085-2 Listed - File No. E258346
- ABS Type Approval (Marine Duty Service and Offshore Applications)

Titan X only:

CE  II 3G
DEMKO 21 ATEX 2235X

IECEX UL 21.0116X
EX ec IIC t3 Gc



UL21UKEX2340X

Features & Benefits

Single Phase

- Copper winding
- Electrostatic shield
- Standard wall mounting with keyhole mounting slots
- Front accessible hinged door
- Standard Type 3R enclosure suitable for indoor or outdoor applications

Three Phase

- Higher impedance designs lower inrush and short circuit currents, allowing the use of less costly protective devices
- Completely encapsulated in epoxy and silica to prevent the ingress of moisture
- Standard 10kV BIL rating provides increased reliability and protection against critical equipment failure (including voltage spikes and other line transients)
- Copper winding
- Electrostatic shield
- Improved efficiency level that reduces energy costs
- Standard Type 4 enclosure suitable for indoor or outdoor applications
- Removable hinged door allows for easy access to terminations
- Standard integral floor and wall mounting brackets on select kVA's for faster installation
- Optional breather drains ensure that any moisture build-up due to condensation is easily eliminated without compromising Type 4/12 enclosure integrity (standard for HPS Titan X)

Temperature Code* - Titan N:

- Class 1, Zone 2, Group IIC, T3
- T3A (115°C rise units) at 40°C ambient
- T3C (80°C & 95°C rise units) at 40°C ambient
- 80°C and 95°C rise units are suitable for 50°C ambient
80°C rise at 50°C ambient maintains T3C performance
95°C rise at 50°C ambient maintains T3A performance
(95°C rise unit only available in three phase)

* For three phase units only

Installation made fast & easy!

The improved three phase enclosure design allows for quick and easy installation. By simply loosening the screw clips on the side of the enclosure, installers are able to access the terminations. The removable hinged door and front accessible terminations allow for easier cable installation in confined spaces.

Testing

All HPS transformers are tested at HPS prior to shipment. They must meet very stringent quality criteria prior to release.



Three Phase

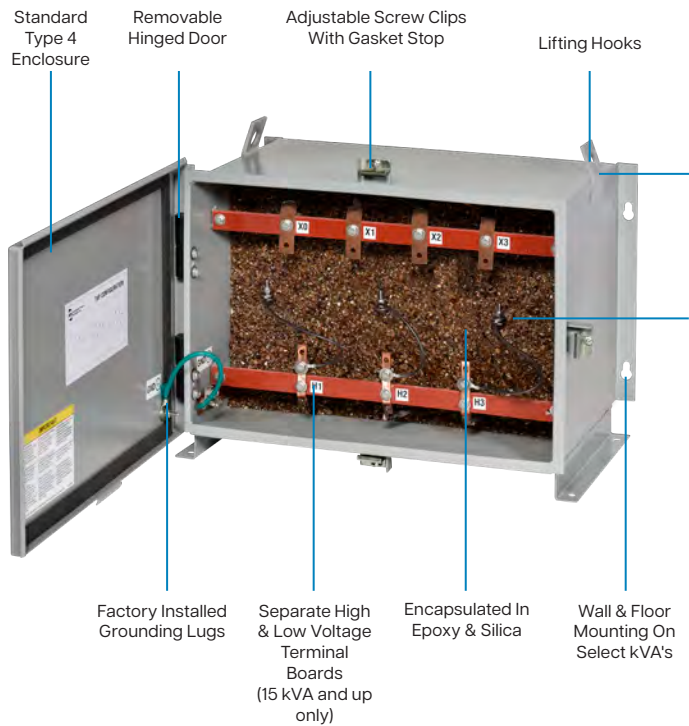

Single Phase

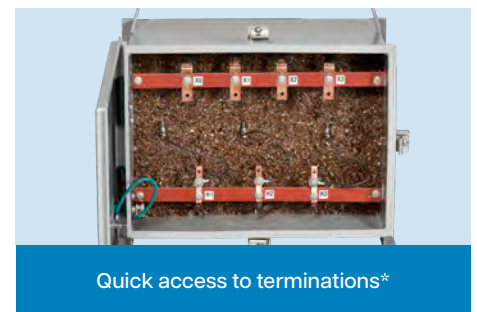
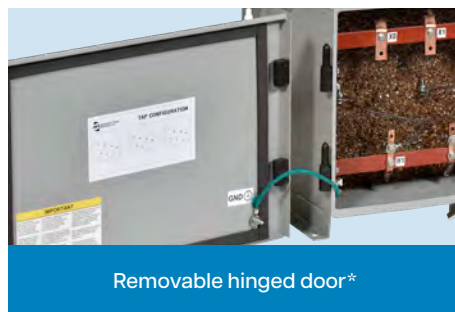
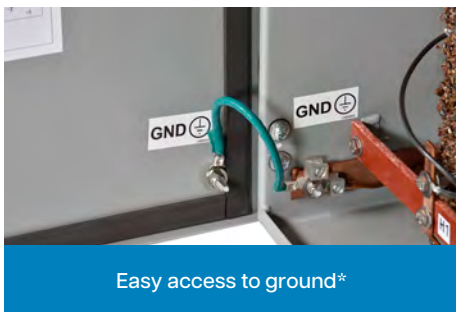

*On three phase units

Specifications & Accessories - Single Phase



Standard Specifications

kVA:	Up to 37.5kVA
UL Listed:	File: E258346
Frequency:	60 Hz (50/60Hz options available)
Insulation System:	130°C (80°C rise) up to 1 kVA 180°C (115°C rise) 1.5 to 37.5 kVA Optional 180°C (80°C rise) 1.5 to 37.5 kVA
Enclosure Type:	Heavy duty enclosed Type 3R standard [Optional Type 4, 12, 4X]
Enclosure Finish:	ANSI 61 Grey
Standard Primary Taps:	Refer to wiring diagrams for details
Termination:	Front accessible separated high and low voltage lead wires or copper tabs
Conduit Entry:	Rear or side entry
Impedance:	Typically 1% to 7%
Seismic:	Seismically qualified according to the International Building Code (IBC) 2018, and the American Society of Civil Engineers ASCE 7-10 specifications, with the following design parameters: Spectral acceleration: $S_{DS} \leq 2.0$ g Importance factor: $I_p = 1.5$ Attachment/height ratio: $z/h = 1.0$ " OSHDPD California Certified
Sound Level:	Meets NEMA ST-20 standards (Optional low noise units available)
Warranty:	10 years

Specifications & Accessories - Three Phase



Standard Specifications - HPS Titan N

kVA:	Up to 150kVA
Frequency:	60 Hz or 50/60 Hz
Insulation System:	80°C rise (130°C class) - 2 & 3 kVA only 115°C rise (180°C class) Optional 80°C & 95°C (180°C class)
Enclosure Type:	Heavy duty enclosed Type 4 standard (also meets Type 12) [Optional Type 4X]
Condensate Valve:	None Valve recommended for environments where condensation may be present
Optional Accessories:	Glass filled Nylon condensate valve Part number: PLG19000
UL Listed:	File: E258346

Standard Specifications - HPS Titan X

kVA:	6-75kVA
Frequency:	60 Hz or 50/60 Hz
Insulation System:	115°C rise (180°C class) Optional 80°C (180°C class)
Enclosure Type:	IP66 (optional IP66X)
Condensate Valve:	Glass filled Nylon
Optional Accessories (Factory Installed):	Stainless steel condensate valve
IECEX Certified:	IECEX UL 20.0021X
ATEX:	DEMKO 20 ATEX 2235X
UKCA:	UL21UKEX2340X

Available for HPS Titan N and HPS Titan X

Enclosure Finish:	ANSI 61 Gray, UL50E textured powdered coating or stainless steels
BIL Rating:	10kV
Neutral:	Neutral Terminal for field connection (on applicable units)
Standard Primary Taps:	Refer to wiring diagram for details
Termination	Front accessible separate high and low voltage terminals on select units
Conduit Entry:	Side or bottom enclosure entry (exceptions apply on bottom entry)
Impedance:	Typically 1.8% to 6.5%
Mounting:	Floor or wall/ceiling mounting available (refer to selection tables for details)
Seismic:	Seismically qualified according to the International Building Code (IBC) 2018, and the American Society of Civil Engineers ASCE 7-10 specifications, with the following design parameters: Spectral acceleration: $S_{DS} \leq 2.0$ g Importance factor: $I_p = 1.5$ Attachment/height ratio: $z/h = 1.0$ " OSHPD California Certified
Sound Level:	Meets NEMA ST-20 standards
Warranty:	10 years

HPS Titan Series Encapsulated Transformers

HPS Titan Single Phase Part Number Guide

Example

Family	kVA			Pri. Volt.	Sec. Volt.	Winding Material/ Electrostatic Shield	Temp. Rise & Insul. Class	Enclosure
Q	0	0	5	L	E	K	B	3

Family	kVA Rating	Primary Voltage	Winding Material:
Q - Titan 1PH	0.5 kVA - C50 0.75 kVA - C75 1.5 kVA - 1C5 2 kVA - 002 3 kVA - 003 5 kVA - 005 7.5 kVA - 007 10 kVA - 010 15 kVA - 015 25 kVA - 025 37.5 kVA - 037 50 kVA - 050	1PH: L - 240X480 J - 347/380 P - 600 Y - 600 X - Export Secondary Voltage 1PH: E - 120/240	C - Copper K - cu + Shield - above 500VA Temperature Rise & Insulation Class B - 80°C ^{1,3} F - 115°C ² Enclosure: 3 - Type 3R* 4 - Type 4 6 - Type 4X (304SS) 7 - Type 4X (316SS) 5 - Type 12



*Default options - ignore if all following characters are default values
¹ 80°C rise is standard on units up to and including 1kVA (130°C insulation class, T3C temperature code)
² 115°C rise is standard on units 1.5kVA and above (180°C insulation class, T3C temperature code)
³ 80°C rise is optional on units 1.5kVA and above (180°C insulation class, T3C temperature code)

HPS Titan N Three Phase Part Number Guide

Example

Family	Appl. Type	Generation	Phase	kVA			Pri. Volt.	Sec. Volt.	Winding Material/ Electrostatic Shield	Temp. Rise & Insul. Class	Frequency	Enclosure	
T	N	2	A	0	0	4	5	K	B	K	B	6	H

Family	kVA Ratings	Primary Voltage	Winding Material
T - Titan	Titan N: 2kVA to 150kVA	3PH G - 380D ¹ H - 400D ¹ J - 415V ¹ K - 480D P - 600D, 600Y Q - 600D, 480D	K - CU + Shield
Type	2 kVA - 0002 3 kVA - 0003 6 kVA - 0006 9 kVA - 0009	Secondary Voltage 3PH B - 208Y/120 C - 230Y/133 D - 240D, 240Y/139, or 240D/120CT G - 380Y/220 H - 400Y/231 K - 480Y/277 P - 600Y/347	Temperature Rise A - 80°C Rise (130°C Class) B - 80°C Rise (180°C Class) C - 95°C Rise (180°C Class) F - 115°C Rise (180°C Class)
Generation	15 kVA - 0015 30 kVA - 0030 45 kVA - 0045		Frequency 5 - 50/60Hz 6 - 60Hz*
2 - current designs	75 kVA - 0075 112.5 kVA - 0112 150 kVA - 0150		Enclosure F - Type 4* ² G - Type 4X (304SS) H - Type 4X (316SS)
Phase (Pri-Sec)			
A - 3PH Delta-Wye-N B - 3PH Wye-N-Delta C - 3PH Delta-Delta/CT D - 3PH Delta-Delta			



¹Units with primary voltage code "G", "H" & "J" come standard as 50/60Hz and are CE marked. All others are 60Hz by default
*Default Options - ignore if all following characters are Default values (applicable to type N only)
²Type 4 enclosure is also Type 12
³Units with primary voltage code "U" only available with type X transformer and come standard as 50/60Hz

HPS Titan X Three Phase Part Number Guide

Example

Family	Appl. Type	Generation	Phase	kVA				Pri. Volt.	Sec. Volt.	Winding Material/ Electrostatic Shield	Temp. Rise & Insul. Class	Frequency	Enclosure
T	X	2	A	0	0	4	5	K	B	K	B	6	H

Family	kVA	Primary Voltage ³	Winding Material/Electrostatic Shield	Frequency
T - Titan	kVA Rating Titan N: 2kVA to 150kVA	3PH G - 380D ¹ H - 400D ¹ J - 415V ¹ K - 480D P - 600D, 600Y Q - 600D, 480D U - 690D	K - CU + Shield	5 - 50/60Hz 6 - 60Hz*
Type			Temperature Rise	Enclosure (IP66/IP66X)
X - Hazardous Location (IECEX & ATEX & ABS Approval)	6 kVA - 0006 9 kVA - 0009 15 kVA - 0015 30 kVA - 0030 45 kVA - 0045 75 kVA - 0075		B - 80°C Rise (180°C Class) F - 115°C Rise (180°C Class)	F - Type 4* ² G - Type 4X (304SS) H - Type 4X (316SS)
Generation		Secondary Voltage³		
2 - current designs		3PH B - 208Y/120 C - 230Y/133 D - 240D, 240Y/139, or 240D/120CT G - 380Y/220 H - 400Y/231 K - 480Y/277 P - 600Y/347 U - 690Y/400		
Phase (Pri-Sec)				
A - 3PH Delta-Wye-N B - 3PH Wye-N-Delta C - 3PH Delta-Delta/CT D - 3PH Delta-Delta				

¹Units with primary voltage code "G", "H", "J" & "U" come standard as 50/60Hz. All others are 60Hz by default

*Default Options

²Type 4 enclosure is also Type 12

³kVA's and/or voltage outside of the scope of standard offering listed are available, however they must fall within the range of 60kVA - 75kVA and/or 208D/Y-690D/Y respectively

Advantages of IECEx Certification*

Available with HPS Titan X



There is an increasing need for installation efficiency and safety in industrial automation and hazardous locations. Equipment, especially electrical, and their use in these areas are covered by a wide range of IEC Standards and are generally highly regulated.

The use of the IECEx Conformity Assessment System and its Schemes offer some key advantages:

Enhanced Safety



Equipment, installations and systems are manufactured, operated and maintained in compliance with IEC International Standards.

Simple Online Verification



All issued IECEx Certificates are available for verification on www.iecex.com or on the IECEx app.

UN Endorsement



The United Nations, via UNECE, has endorsed IECEx as the internationally-recognized certification system for promoting the improved safety of equipment, services and personnel associated with devices, systems and installations used in Ex areas.

Cost Reductions



IECEX certification reduces the need for additional testing and certification which can lower costs and streamline processes.

*Source: <https://www.iecex.com/assets/Uploads/IECEX-brochure-LR-16.pdf>

SELECTION TABLES

HPS TITAN

Encapsulated Transformer



Copper Wound, Single Phase

*208/240/277 PRIMARY VOLTS 120/240 SECONDARY VOLTS 60 HZ

kVA	Catalog Number	Case Style	Approx. Dimensions - Inches [mm]			°C Temp. Rise	Approx. Weight Lbs [kg]	Mtg Type W - Wall F - Floor	Wiring Diagram
			Width	Depth	Height				
0.5	QC50YECB	NQ2	5.06 [128]	4.56 [116]	9.30 [236]	80	19 [9]	W	SCD 3.1
0.75	QC75YEKB	NQ2	5.06 [128]	4.56 [116]	9.30 [236]	80	21 [10]	W	SCD 3.1
1	Q1C0YEKB	NQ3	5.88 [149]	5.19 [132]	10.56 [268]	80	28 [13]	W	SCD 3.1
1.5	Q1C5YEKF	NQ3	5.88 [149]	5.19 [132]	10.56 [268]	115	36 [16]	W	SCD 3.1
2	Q002YEKF	NQ4	7.06 [179]	6.25 [159]	11.75 [298]	115	44 [19.8]	W	SCD 3.1
3	Q003YEKF	NQ4	7.06 [179]	6.25 [159]	11.75 [298]	115	56 [25.2]	W	SCD 3.1
5	Q005YEKF	NQ5	10.00 [254]	7.75 [197]	17.25 [438]	115	134 [61]	W	SCD 3.1
7.5	Q007YEKF	NQ5	10.00 [254]	7.75 [197]	17.25 [438]	115	160 [72]	W	SCD 3.1
10	Q010YEKF	NQ6	12.25 [311]	9.25 [235]	20.88 [530]	115	204 [92]	W	SCD 3.1
15	Q015YEKF	NQ6	12.25 [311]	9.25 [235]	20.88 [530]	115	248 [112]	W	SCD 3.1
25	Q025YEKF	NQ7	14.50 [368]	10.75 [273]	21.38 [543]	115	345 [156]	W	SCD 3.1
37.5	Q037YEKF	NQ8	14.50 [368]	10.75 [273]	27.38 [695]	115	476 [215]	W	SCD 3.1

*347/380 PRIMARY VOLTS 120/240 SECONDARY VOLTS 50/60HZ



kVA	Catalog Number	Case Style	Approx. Dimensions - Inches [mm]			°C Temp. Rise	Approx. Weight Lbs [kg]	Mtg Type W - Wall F - Floor	Wiring Diagram
			Width	Depth	Height				
0.5	QC50FECEB	NQ2	5.06 [128]	4.56 [116]	9.30 [236]	80	19 [9]	W	SCD 5.1
0.75	QC75FECEB	NQ2	5.06 [128]	4.56 [116]	9.30 [236]	80	21 [10]	W	SCD 5.1
1	Q1C0FECEB	NQ3	5.88 [149]	5.19 [132]	10.56 [268]	80	28 [13]	W	SCD 5.1
1.5	Q1C5FEKF	NQ3	5.88 [149]	5.19 [132]	10.56 [268]	115	36 [16]	W	SCD 5.1
2	Q002FEKF	NQ4	7.06 [179]	6.25 [159]	11.75 [298]	115	44 [19.8]	W	SCD 5.1
3	Q003FEKF	NQ5	7.06 [179]	6.25 [159]	11.75 [298]	115	56 [25.2]	W	SCD 5.1
5	Q005FEKF	NQ5	10.00 [254]	7.75 [197]	17.25 [438]	115	134 [61]	W	SCD 5.1
7.5	Q007FEKF	NQ6	10.00 [254]	7.75 [197]	17.25 [438]	115	160 [72]	W	SCD 5.1
10	Q010FEKF	NQ6	12.25 [311]	9.25 [235]	20.88 [530]	115	204 [92]	W	SCD 5.1
15	Q015FEKF	NQ6	12.25 [311]	9.25 [235]	20.88 [530]	115	248 [112]	W	SCD 5.1
25	Q025FEKF	NQ7	14.50 [368]	10.75 [273]	21.38 [543]	115	345 [156]	W	SCD 5.1
37.5	Q037FEKF	NQ8	14.50 [368]	10.75 [273]	27.38 [695]	115	476 [215]	W	SCD 5.1

*240X480 PRIMARY VOLTS 120/240 SECONDARY VOLTS 60 HZ

kVA	Catalog Number	Case Style	Approx. Dimensions - Inches [mm]			°C Temp. Rise	Approx. Weight Lbs [kg]	Mtg Type W - Wall F - Floor	Wiring Diagram
			Width	Depth	Height				
0.5	QC50LECEB	NQ2	5.06 [128]	4.56 [116]	9.30 [236]	80	23 [10.4]	W	SCD 1.1
0.75	QC75LECEB	NQ2	5.06 [128]	4.56 [116]	9.30 [236]	80	24 [10.8]	W	SCD 1.1
1	Q1C0LECEB	NQ3	5.88 [149]	5.19 [132]	10.56 [268]	80	28 [12.6]	W	SCD 1.1
1.5	Q1C5LEKF	NQ3	5.88 [149]	5.19 [132]	10.56 [268]	115	35 [15.8]	W	SCD 1.1
2	Q002LEKF	NQ4	7.06 [179]	6.25 [159]	11.75 [298]	115	47 [21.2]	W	SCD 1.1
3	Q003LEKF	NQ5	7.06 [179]	6.25 [159]	11.75 [298]	115	62 [27.9]	W	SCD 1.1
5	Q005LEKF	NQ5	10.00 [254]	7.75 [197]	17.25 [438]	115	131 [59.0]	W	SCD 1.1
7.5	Q007LEKF	NQ6	10.00 [254]	7.75 [197]	17.25 [438]	115	155 [69.8]	W	SCD 1.1
10	Q010LEKF	NQ6	12.25 [311]	9.25 [235]	20.88 [530]	115	220 [99.0]	W	SCD 1.1
15	Q015LEKF	NQ6	12.25 [311]	9.25 [235]	20.88 [530]	115	248 [112]	W	SCD 1.1
25	Q025LEKF	NQ7	14.50 [368]	10.75 [273]	21.38 [543]	115	345 [156]	W	SCD 1.1
37.5	Q037LEKF	NQ8	14.50 [368]	10.75 [273]	27.38 [695]	115	476 [215]	W	SCD 1.1

SELECTION TABLES

HPS TITAN

Encapsulated Transformer



Copper Wound, Single Phase

*600 PRIMARY VOLTS 120/240 SECONDARY VOLTS 60 HZ

kVA	Catalog Number	Case Style	Approx. Dimensions - Inches [mm]			°C Temp. Rise	Approx. Weight Lbs [kg]	Mtg Type W - Wall F - Floor	Wiring Diagram
			Width	Depth	Height				
0.5	QC50PECB	NQ2	5.06 [128]	4.56 [116]	9.30 [236]	80	15 [6.8]	W	SCD 2.1
0.75	QC75PEKB	NQ2	5.06 [128]	4.56 [116]	9.30 [236]	80	18 [8.1]	W	SCD 2.1
1	Q1C0PEKB	NQ3	5.88 [149]	5.19 [132]	10.56 [268]	80	27 [12.2]	W	SCD 2.1
1.5	Q1C5PEKF	NQ3	5.88 [149]	5.19 [132]	10.56 [268]	115	31 [14.0]	W	SCD 2.1
2	Q002PEKF	NQ4	7.06 [179]	6.25 [159]	11.75 [298]	115	40 [18.0]	W	SCD 2.1
3	Q003PEKF	NQ4	7.06 [179]	6.25 [159]	11.75 [298]	115	52 [23.4]	W	SCD 2.1
5	Q005PEKF	NQ5	10.00 [254]	7.75 [197]	17.25 [438]	115	114 [51.3]	W	SCD 2.1
7.5	Q007PEKF	NQ5	10.00 [254]	7.75 [197]	17.25 [438]	115	129 [58.1]	W	SCD 2.1
10	Q010PEKF	NQ6	12.25 [311]	9.25 [235]	20.88 [530]	115	197 [88.7]	W	SCD 2.1
15	Q015PEKF	NQ6	12.25 [311]	9.25 [235]	20.88 [530]	115	234 [106]	W	SCD 2.1
25	Q025PEKF	NQ7	14.50 [368]	10.75 [273]	21.38 [543]	115	285 [129]	W	SCD 2.1
37.5	Q037PEKF	NQ8	14.50 [368]	10.75 [273]	27.38 [695]	115	454 [205]	W	SCD 2.1



*EXPORT¹ PRIMARY VOLTS 120/240 SECONDARY VOLTS 50/60 HZ

kVA	Catalog Number	Case Style	Approx. Dimensions - Inches [mm]			°C Temp. Rise	Approx. Weight Lbs [kg]	Mtg Type W - Wall F - Floor	Wiring Diagram
			Width	Depth	Height				
0.5	QC50XECEB	NQ2	5.06 [128]	4.56 [116]	9.30 [236]	80	15 [6.8]	W	SCD 4.1
0.75	QC75XECEB	NQ2	5.06 [128]	4.56 [116]	9.30 [236]	80	20 [9.0]	W	SCD 4.1
1	Q1C0XECEB	NQ3	5.88 [149]	5.19 [132]	10.56 [268]	80	32 [14.4]	W	SCD 4.1
1.5	Q1C5XEKEF	NQ3	5.88 [149]	5.19 [132]	10.56 [268]	115	35 [15.8]	W	SCD 4.1
2	Q002XEKEF	NQ4	7.06 [179]	6.25 [159]	11.75 [298]	115	54 [24.3]	W	SCD 4.1
3	Q003XEKEF	NQ5	10.00 [254]	7.75 [197]	17.25 [438]	115	105 [47.3]	W	SCD 4.1
5	Q005XEKEF	NQ5	10.00 [254]	7.75 [197]	17.25 [438]	115	138 [62.1]	W	SCD 4.1
7.5	Q007XEKEF	NQ6	12.25 [311]	9.25 [235]	20.88 [530]	115	189 [85.1]	W	SCD 4.1
10	Q010XEKEF	NQ6	12.25 [311]	9.25 [235]	20.88 [530]	115	222 [99.9]	W	SCD 4.1
15	Q015XEKEF	NQ7	14.50 [368]	10.75 [273]	21.38 [543]	115	300 [135]	W	SCD 4.1
25	Q025XEKEF								Consult HPS
37.5	Q037XEKEF								Consult HPS

¹Export = 190/200/208/220/240² X 380/400/415/440/480² Primary Volts

²The primary voltage ratio of 240 or 480 is available at 60Hz only with secondary voltage of approximately 130/262V.

***Single Phase Notes:**

Units ending with letter "B" are 80°C rise

Units ending with letter "F" are 115°C rise; 80°C rise optional replace end suffix "F" with "B"

80°C rise units are T3C; 115°C rise units are T3A.

For shielded units 0.50kVA, replace the suffix "CB" with a "KB"

Refer to wiring diagrams for tap details

SELECTION TABLES

HPS TITAN N

Encapsulated Transformer



Copper Wound, Three Phase

480D PRIMARY VOLTS 208Y/120 SECONDARY VOLTS 60 HZ

kVA	Catalog Number	Case Style	Approx. Dimensions - Inches [mm]			Full Capacity Taps	°C Temp. Rise	Approx. Weight Lbs [kg]	Mtg Type W - Wall F - Floor	Wiring Diagram
			Width	Depth	Height					
2	TN2A0002KBKA	DQT1	13.13 [333]	9.13 [232]	13.38 [340]	2 - 5% 1FCAN, 1FCBN	80	74 [33.3]	W/F	SCD 1.3
3	TN2A0003KBKA	DQT1	13.13 [333]	9.13 [232]	13.38 [340]	2 - 5% 1FCAN, 1FCBN	80	78 [35.1]	W/F	SCD 1.3
6	TN2A0006KBKF	DQT2	15.88 [403]	9.88 [251]	15.38 [391]	2 - 5% 1FCAN, 1FCBN	115	140 [63]	W/F	SCD 1.3
9	TN2A0009KBKF	DQT3	19.13 [486]	11.88 [302]	14.69 [373]	2 - 5% 1FCAN, 1FCBN	115	200 [90]	W/F	SCD 1.3
15	TN2A0015KBKF	DQT4	22.38 [568]	13.88 [352]	17.25 [438]	6 - 2.5% 2FCAN, 4FCBN	115	310 [140]	W/F	SCD 2.3
30	TN2A0030KBKF	DQT5	25.88 [657]	16.50 [419]	21.88 [556]	6 - 2.5% 2FCAN, 4FCBN	115	510 [230]	F (Opt. W)	SCD 2.3
45	TN2A0045KBKF	DQT6	26.13 [664]	19.75 [502]	21.88 [556]	6 - 2.5% 2FCAN, 4FCBN	115	635 [286]	F (Opt. W)	SCD 2.3
75	TN2A0075KBKF	DQT7	32.38 [822]	22.00 [559]	25.63 [651]	6 - 2.5% 2FCAN, 4FCBN	115	1180 [531]	F	SCD 2.3
112.5	TN2A0112KBKF	DQT9	36.63 [930]	30.75 [781]	25.63 [651]	6 - 2.5% 2FCAN, 4FCBN	115	2000 [900]	F	SCD 2.3
150	TN2A0150KBKF	DQT10	36.63 [930]	30.50 [775]	31.38 [797]	6 - 2.5% 2FCAN, 4FCBN	115	2700 [1215]	F	SCD 2.3

Refer to wiring diagrams for tap details

Opt. W: Wall Mouting Kit " DQTW1 Available

480D PRIMARY VOLTS 240D SECONDARY VOLTS 60 HZ

kVA	Catalog Number	Case Style	Approx. Dimensions - Inches [mm]			Full Capacity Taps	°C Temp. Rise	Approx. Weight Lbs [kg]	Mtg Type W - Wall F - Floor	Wiring Diagram
			Width	Depth	Height					
2	TN2D0002KDKA	DQT1	13.13 [333]	9.13 [232]	13.38 [340]	2 - 5% 1FCAN, 1FCBN	80	74 [33.3]	W/F	SCD 3.3
3	TN2D0003KDKA	DQT1	13.13 [333]	9.13 [232]	13.38 [340]	2 - 5% 1FCAN, 1FCBN	80	78 [35.1]	W/F	SCD 3.3
6	TN2D0006KDKF	DQT2	15.88 [403]	9.88 [251]	15.38 [391]	2 - 5% 1FCAN, 1FCBN	115	140 [63]	W/F	SCD 3.3
9	TN2D0009KDKF	DQT3	19.13 [486]	11.88 [302]	14.69 [373]	2 - 5% 1FCAN, 1FCBN	115	200 [90]	W/F	SCD 3.3
15	TN2D0015KDKF	DQT4	22.38 [568]	13.88 [352]	17.25 [438]	6 - 2.5% 2FCAN, 4FCBN	115	310 [140]	W/F	SCD 4.3
30	TN2D0030KDKF	DQT5	25.88 [657]	16.50 [419]	21.88 [556]	6 - 2.5% 2FCAN, 4FCBN	115	510 [230]	F (Opt. W)	SCD 4.3
45	TN2D0045KDKF	DQT6	26.13 [664]	19.75 [502]	21.88 [556]	6 - 2.5% 2FCAN, 4FCBN	115	635 [286]	F (Opt. W)	SCD 4.3
75	TN2D0075KDKF	DQT7	32.38 [822]	22.00 [559]	25.63 [651]	6 - 2.5% 2FCAN, 4FCBN	115	1180 [531]	F	SCD 4.3
112.5	TN2D0112KDKF	DQT9	36.63 [930]	30.75 [781]	25.63 [651]	6 - 2.5% 2FCAN, 4FCBN	115	2000 [900]	F	SCD 4.3
150	TN2D0150KDKF	DQT10	36.63 [930]	30.50 [775]	31.38 [797]	6 - 2.5% 2FCAN, 4FCBN	115	2700 [1215]	F	SCD 4.3

Refer to wiring diagrams for tap details

Opt. W: Wall Mouting Kit " DQTW1 Available

480D PRIMARY VOLTS 400Y/231 SECONDARY VOLTS 60 HZ

kVA	Catalog Number	Case Style	Approx. Dimensions - Inches [mm]			Full Capacity Taps	°C Temp. Rise	Approx. Weight Lbs [kg]	Mtg Type W - Wall F - Floor	Wiring Diagram
			Width	Depth	Height					
2	TN2A0002KHKA	DQT1	13.13 [333]	9.13 [232]	13.38 [340]	2 - 5% 1FCAN, 1FCBN	80	74 [33.3]	W/F	SCD 1.3
3	TN2A0003KHKA	DQT1	13.13 [333]	9.13 [232]	13.38 [340]	2 - 5% 1FCAN, 1FCBN	80	78 [35.1]	W/F	SCD 1.3
6	TN2A0006KHKF	DQT2	15.88 [403]	9.88 [251]	15.38 [391]	2 - 5% 1FCAN, 1FCBN	115	140 [63]	W/F	SCD 1.3
9	TN2A0009KHKF	DQT3	19.13 [486]	11.88 [302]	14.69 [373]	2 - 5% 1FCAN, 1FCBN	115	200 [90]	W/F	SCD 1.3
15	TN2A0015KHKF	DQT4	22.38 [568]	13.88 [352]	17.25 [438]	6 - 2.5% 2FCAN, 4FCBN	115	310 [140]	W/F	SCD 2.3
30	TN2A0030KHKF	DQT5	25.88 [657]	16.50 [419]	21.88 [556]	6 - 2.5% 2FCAN, 4FCBN	115	510 [230]	F (Opt. W)	SCD 2.3
45	TN2A0045KHKF	DQT6	26.13 [664]	19.75 [502]	21.88 [556]	6 - 2.5% 2FCAN, 4FCBN	115	635 [286]	F (Opt. W)	SCD 2.3
75	TN2A0075KHKF	DQT7	32.38 [822]	22.00 [559]	25.63 [651]	6 - 2.5% 2FCAN, 4FCBN	115	1180 [531]	F	SCD 2.3
112.5	TN2A0112KHKF	DQT9	36.63 [930]	30.75 [781]	25.63 [651]	6 - 2.5% 2FCAN, 4FCBN	115	2000 [900]	F	SCD 2.3
150	TN2A0150KHKF	DQT10	36.63 [930]	30.50 [775]	31.38 [797]	6 - 2.5% 2FCAN, 4FCBN	115	2700 [1215]	F	SCD 2.3

Refer to wiring diagrams for tap details

Opt. W: Wall Mouting Kit " DQTW1 Available

SELECTION TABLES

HPS TITAN N

Encapsulated Transformer



Copper Wound, Three Phase

600D PRIMARY VOLTS			208Y/120 SECONDARY VOLTS					60 HZ		
kVA	Catalog Number	Case Style	Approx. Dimensions - Inches [mm]			Full Capacity Taps	°C Temp. Rise	Approx. Weight Lbs [kg]	Mtg Type W - Wall F - Floor	Wiring Diagram
			Width	Depth	Height					
2	TN2A0002PBKA	DQT1	13.13 [333]	9.13 [232]	13.38 [340]	2 - 5% 1FCAN, 1FCBN	80	74 [33.3]	W/F	SCD 1.3
3	TN2A0003PBKA	DQT1	13.13 [333]	9.13 [232]	13.38 [340]	2 - 5% 1FCAN, 1FCBN	80	78 [35.1]	W/F	SCD 1.3
6	TN2A0006PBKF	DQT2	15.88 [403]	9.88 [251]	15.38 [391]	2 - 5% 1FCAN, 1FCBN	115	140 [63]	W/F	SCD 1.3
9	TN2A0009PBKF	DQT3	19.13[486]	11.88 [302]	14.69 [373]	2 - 5% 1FCAN, 1FCBN	115	200 [90]	W/F	SCD 1.3
15	TN2A0015PBKF	DQT4	22.38 [568]	13.88 [352]	17.25 [438]	6 - 2.5% 2FCAN, 4FCBN	115	310 [140]	W/F	SCD 2.3
30	TN2A0030PBKF	DQT5	25.88 [657]	16.50 [419]	21.88 [556]	6 - 2.5% 2FCAN, 4FCBN	115	510 [230]	F (Opt. W)	SCD 2.3
45	TN2A0045PBKF	DQT6	26.13 [664]	19.75 [502]	21.88 [556]	6 - 2.5% 2FCAN, 4FCBN	115	635 [286]	F (Opt. W)	SCD 2.3
75	TN2A0075PBKF	DQT7	32.38 [822]	22.00 [559]	25.63 [651]	6 - 2.5% 2FCAN, 4FCBN	115	1180 [531]	F	SCD 2.3
112.5	TN2A0112PBKF	DQT9	36.63 [930]	30.75 [781]	25.63 [651]	6 - 2.5% 2FCAN, 4FCBN	115	2000 [900]	F	SCD 2.3
150	TN2A0150PBKF	DQT10	36.63 [930]	30.50 [775]	31.38 [797]	6 - 2.5% 2FCAN, 4FCBN	115	2700 [1215]	F	SCD 2.3

Refer to wiring diagrams for tap details

Opt. W: Wall Mounting Kit "DQTW1 Available

600D, 480D PRIMARY VOLTS			480Y/277 SECONDARY VOLTS					60 HZ		
kVA	Catalog Number	Case Style	Approx. Dimensions - Inches [mm]			Full Capacity Taps	°C Temp. Rise	Approx. Weight Lbs [kg]	Mtg Type W - Wall F - Floor	Wiring Diagram
			Width	Depth	Height					
2	TN2A0002QKKA	DQT1	13.13 [333]	9.13 [232]	13.38 [340]	3 - 5% 1FCAN, 2FCBN	80	74 [33.3]	W/F	SCD 5.3
3	TN2A0003QKKA	DQT1	13.13 [333]	9.13 [232]	13.38 [340]	3 - 5% 1FCAN, 2FCBN	80	78 [35.1]	W/F	SCD 5.3
6	TN2A0006QKKF	DQT2	15.88 [403]	9.88 [251]	15.38 [391]	3 - 5% 1FCAN, 2FCBN	115	140 [63]	W/F	SCD 5.3
9	TN2A0009QKKF	DQT3	19.13[486]	11.88 [302]	14.69 [373]	3 - 5% 1FCAN, 2FCBN	115	200 [90]	W/F	SCD 5.3
15	TN2A0015QKKF	DQT4	22.38 [568]	13.88 [352]	17.25 [438]	3 - 5% 1FCAN, 2FCBN	115	310 [140]	W/F	SCD 6.3
30	TN2A0030QKKF	DQT5	25.88 [657]	16.50 [419]	21.88 [556]	3 - 5% 1FCAN, 2FCBN	115	510 [230]	F (Opt. W)	SCD 6.3
45	TN2A0045QKKF	DQT6	26.13 [664]	19.75 [502]	21.88 [556]	3 - 5% 1FCAN, 2FCBN	115	635 [286]	F (Opt. W)	SCD 6.3
75	TN2A0075QKKF	DQT7	32.38 [822]	22.00 [559]	25.63 [651]	3 - 5% 1FCAN, 2FCBN	115	1180 [531]	F	SCD 6.3
112.5	TN2A0112QKKF	DQT9	36.63 [930]	30.75 [781]	25.63 [651]	3 - 4.5% 1FCAN, 2FCBN	115	2000 [900]	F	SCD 6.3
150	TN2A0150QKKF	DQT10	36.63 [930]	30.50 [775]	31.38 [797]	3 - 4.5% 1FCAN, 2FCBN	115	2700 [1215]	F	SCD 6.3

Refer to wiring diagrams for tap details

Opt. W: Wall Mounting Kit "DQTW1 Available

DQTW1 Wall Mounting Kit

The DQTW1 HPS wall mounting kits are specifically designed for standard and custom HPS Titan® N encapsulated distribution transformers.

The DQTW1 kit is can only be used on any unit up to a maximum of 800 pounds (363 kg) that utilizes an HPS DQT5 or DQT6 enclosure. Generally this would be a 30kVA or 45kVA HPS Titan® N unit.

IMPORTANT

Please ensure your wall mounting location and position meets all local building and fire codes and regulations

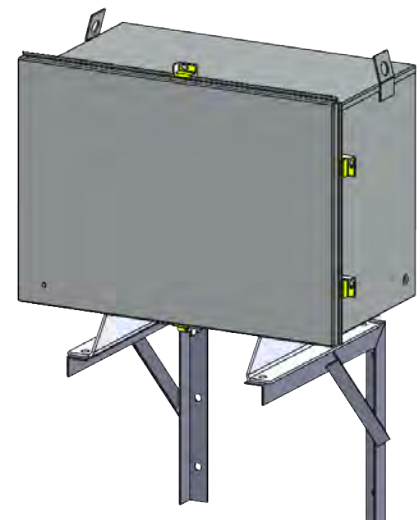

SELECTION TABLES

HPS TITAN

Encapsulated Transformer



IECEX, ATEX & UKEx

480D PRIMARY VOLTS			400Y/231 SECONDARY VOLTS				60 HZ				
kVA	Catalog Number	Case Style	Approx. Dimensions - Inches [mm]			Full Capacity Taps	°C Temp. Rise	Approx. Weight Lbs [kg]	Mtg Type W - Wall F - Floor	Wiring Diagram	
			Width	Depth	Height						
6	TX2A0006KHKF	DQT2	15.88 [403]	9.88 [251]	15.38 [391]	2 - 5% 1FCAN, 1FCBN	115	140 [63.0]	W/F	SCD 1	
9	TX2A0009KHKF	DQT3	13.19 [335]	11.88 [301]	14.69 [373]	2 - 5% 1FCAN, 1FCBN	115	200 [90.0]	W/F	SCD 1	
15	TX2A0015KHKF	DQT4	22.38 [568]	13.88 [352]	17.25 [438]	6 - 2.5% 2FCAN, 4FCBN	115	310 [139.5]	W/F	SCD 2	
30	TX2A0030KHKF	DQT5	25.88 [657]	16.50 [419]	21.88 [556]	6 - 2.5% 2FCAN, 4FCBN	115	510 [229.5]	F (Opt. W)	SCD 2	
45	TX2A0045KHKF	DQT6	26.13 [664]	19.75 [502]	21.88 [556]	6 - 2.5% 2FCAN, 4FCBN	115	635 [285.8]	F (Opt. W)	SCD 2	
75	TX2A0075KHKF	DQT7	32.38 [822]	22.00 [559]	25.63 [651]	6 - 2.5% 2FCAN, 4FCBN	115	1180 [531.0]	F	SCD 2	

Opt. W: Wall Mounting Kit "DQTW1" Available

480D PRIMARY VOLTS			208Y/120 SECONDARY VOLTS				60 HZ				
kVA	Catalog Number	Case Style	Approx. Dimensions - Inches [mm]			Full Capacity Taps	°C Temp. Rise	Approx. Weight Lbs [kg]	Mtg Type W - Wall F - Floor	Wiring Diagram	
			Width	Depth	Height						
6	TX2A0006KBKF	DQT2	15.88 [403]	9.88 [251]	15.38 [391]	2 - 5% 1FCAN, 1FCBN	115	140 [63.0]	W/F	SCD 1	
9	TX2A0009KBKF	DQT3	13.19 [335]	11.88 [301]	14.69 [373]	2 - 5% 1FCAN, 1FCBN	115	200 [90.0]	W/F	SCD 1	
15	TX2A0015KBKF	DQT4	22.38 [568]	13.88 [352]	17.25 [438]	6 - 2.5% 2FCAN, 4FCBN	115	310 [139.5]	W/F	SCD 2	
30	TX2A0030KBKF	DQT5	25.88 [657]	16.50 [419]	21.88 [556]	6 - 2.5% 2FCAN, 4FCBN	115	510 [229.5]	F (Opt. W)	SCD 2	
45	TX2A0045KBKF	DQT6	26.13 [664]	19.75 [502]	21.88 [556]	6 - 2.5% 2FCAN, 4FCBN	115	635 [285.8]	F (Opt. W)	SCD 2	
75	TX2A0075KBKF	DQT7	32.38 [822]	22.00 [559]	25.63 [651]	6 - 2.5% 2FCAN, 4FCBN	115	1180 [531.0]	F	SCD 2	

Opt. W: Wall Mounting Kit "DQTW1" Available

400D PRIMARY VOLTS			230Y/133 SECONDARY VOLTS				50/ 60 HZ				
kVA	Catalog Number	Case Style	Approx. Dimensions - Inches [mm]			Full Capacity Taps	°C Temp. Rise	Approx. Weight Lbs [kg]	Mtg Type W - Wall F - Floor	Wiring Diagram	
			Width	Depth	Height						
6	TX2A0006HCKF5	DQT3	13.19 [335]	11.88 [302]	14.69 [373]	2 - 5% 1FCAN, 1FCBN	115	205 [92.2]	W/F	SCD 1	
9	TX2A0009HCKF5	DQT4	22.38 [568]	13.88 [352]	17.25 [438]	2 - 5% 1FCAN, 1FCBN	115	260 [117]	W/F	SCD 1	
15	TX2A0015HCKF5	DQT5	25.88 [657]	16.5 [419]	21.88 [556]	6 - 2.5% 2FCAN, 4FCBN	115	405 [182.2]	W/F	SCD 2	
30	TX2A0030HCKF5	DQT6	26.13 [664]	19.75 [502]	21.88 [556]	6 - 2.5% 2FCAN, 4FCBN	115	530 [238.5]	F (Opt. W)	SCD 2	
45	TX2A0045HCKF5	DQT7	32.38 [822]	22.00 [559]	25.63 [651]	6 - 2.5% 2FCAN, 4FCBN	115	900 [405]	F (Opt. W)	SCD 2	
75	TX2A0075HCKF5	DQT8	35.13 [892]	26.00 [660]	26.63 [676]	6 - 2.5% 2FCAN, 4FCBN	115	1350 [607.5]	F	SCD 2	

Opt. W: Wall Mounting Kit "DQTW1" Available

600D PRIMARY VOLTS			208Y/120 SECONDARY VOLTS				60 HZ				
kVA	Catalog Number	Case Style	Approx. Dimensions - Inches [mm]			Full Capacity Taps	°C Temp. Rise	Approx. Weight Lbs [kg]	Mtg Type W - Wall F - Floor	Wiring Diagram	
			Width	Depth	Height						
6	TX2A0006PBKF	DQT2	15.88 [403]	9.88 [251]	15.38 [391]	2 - 5% 1FCAN, 1FCBN	115	140 [63.0]	W/F	SCD1	
9	TX2A0009PBKF	DQT3	13.19 [335]	11.88 [302]	14.69 [373]	2 - 5% 1FCAN, 1FCBN	115	200 [90.0]	W/F	SCD1	
15	TX2A0015PBKF	DQT4	22.38 [568]	13.88 [352]	17.25 [438]	6 - 2.5% 2FCAN, 4FCBN	115	310 [139.5]	W/F	SCD 2	
30	TX2A0030PBKF	DQT5	25.88 [657]	16.50 [419]	21.88 [556]	6 - 2.5% 2FCAN, 4FCBN	115	510 [229.5]	F (Opt. W)	SCD 2	
45	TX2A0045PBKF	DQT6	26.13 [664]	19.75 [502]	21.88 [556]	6 - 2.5% 2FCAN, 4FCBN	115	635 [285.8]	F (Opt. W)	SCD 2	
75	TX2A0075PBKF	DQT7	32.38 [822]	22.00 [559]	25.63 [651]	6 - 2.5% 2FCAN, 4FCBN	115	1180 [531.0]	F	SCD 2	

Opt. W: Wall Mounting Kit "DQTW1" Available

TYPICAL PERFORMANCE DATA

GENERAL PURPOSE

Single Phase

VOLTAGE RANGE 120V TO 600V
80°C TO 115°C TEMP. RISE

kVA	Impedance	Peak Inrush Current Multiple of RMS Current	
0.55	4-7%	Consult HPS	
0.75			
1			
1.5			
2			
3	1-2%		
5			
7.5			
10	2-4%		30 to 40
15			
25			
37.5			



Three Phase

VOLTAGE RANGE 120V TO 600V
80°C TO 115°C TEMP. RISE

kVA	Impedance	Peak Inrush Current Multiple of RMS Current
2	3.5-6.5%	15 to 20
3		
6		
9	2-5%	
15		
30	1.8-4%	
45		
75		
112.5	1.8-2.5%	6 to 12
150		

kVA	Efficiency (% rated load)		
	100%	50%	35%
2	95.02%	95.97%	94.37%
3	95.96%	97.44%	96.71%
6	95.24%	95.75%	94.67%
9	97.38%	98.23%	97.93%
15	97.79%	98.41%	98.15%*
30	98.28%	98.85%	98.75%*
45	98.60%	98.97%	98.84%*
75	98.93%	99.03%	98.82%*
112.5	99.08%	99.03%	98.82%
150	99.15%	99.13%	98.96%

- Efficiencies are approximate, and not guaranteed
- All efficiencies are based on 75°C reference temperature
- Applies only to 115°C rise, with the exception of 2 & 3 kVA
- *Items from 15-75kVA meet the current minimum efficiency levels in North America (DOE 2016 & NRCAN 2019) for ventilated transformers. Note that these efficiency levels are not required for this non-ventilated offering.

TERMINATION DETAILS

COPPER TERMINATION, LEADS OR PADS

Single Phase Voltage (Primary or Secondary)

kVA	Voltage							
	208	240	277	347	380	400	480	600
0.5								
0.75								
1								
1.5								
2								
3								
5								
7.5								
10	1A	1A	1A					
15	1A	1A	1A	1A	1A	1A	1A	1A
25	1B	1B	1B	1A	1A	1A	1A	1A
37.5	1D	1C	1C	1C	1C	1C	1C	1B

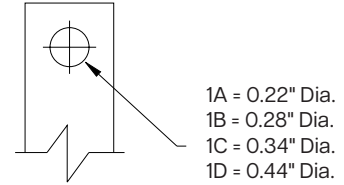

Diagram 1 - Single Phase

HPS Titan N Three Phase Voltages (Primary or Secondary)

kVA	Voltage							
	208	230	240	277	380	400	480	600
2								
3								
6								
9*	1A	1A	1A	1A	1A			
15	1A	1A	1A	1A	1A	1A	1A	1A
30	1A	1A	1A	1A	1A	1A	1A	1A
45	1B	1A	1A	1A	1A	1A	1A	1A
75	1B	1B	1B	1B	1A	1A	1A	1A
112.5	1B	1B	1B	1B	1B	1B	1B	1A
150	1B	1B	1B	1B	1B	1B	1B	1B

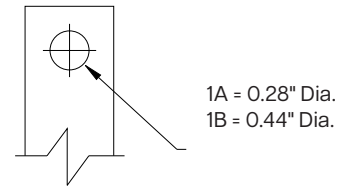

Diagram 1 - Three Phase

* Termination Tab 1A provided on 9 kVA 80°C, and 95°C rise only. Otherwise, 115°C rise have lead wire termination.

HPS Titan X Three Phase Voltages (Primary or Secondary)

kVA	Voltage							
	208	230	240	277	380	400	480	600
6*	1A	1A	1A	1A	1A	1A	1A	1A
9	1A	1A	1A	1A	1A	1A	1A	1A
15	1A	1A	1A	1A	1A	1A	1A	1A
30	1A	1A	1A	1A	1A	1A	1A	1A
15	1A	1A	1A	1A	1A	1A	1A	1A
45	1B	1A	1A	1A	1A	1A	1A	1A
75	1B	1B	1B	1B	1A	1A	1A	1A

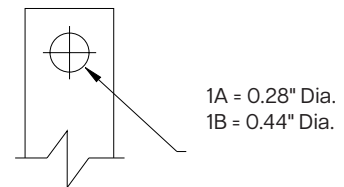

Diagram 1 - Three Phase

* Termination Tab 1A provided on 6 kVA 50Hz or 50/60Hz, 115°C & 80°C rise. For 60Hz 115°C rise, terminal block provided

ENCLOSURE DRAWINGS

DQT SERIES - THREE PHASE

Figure 1

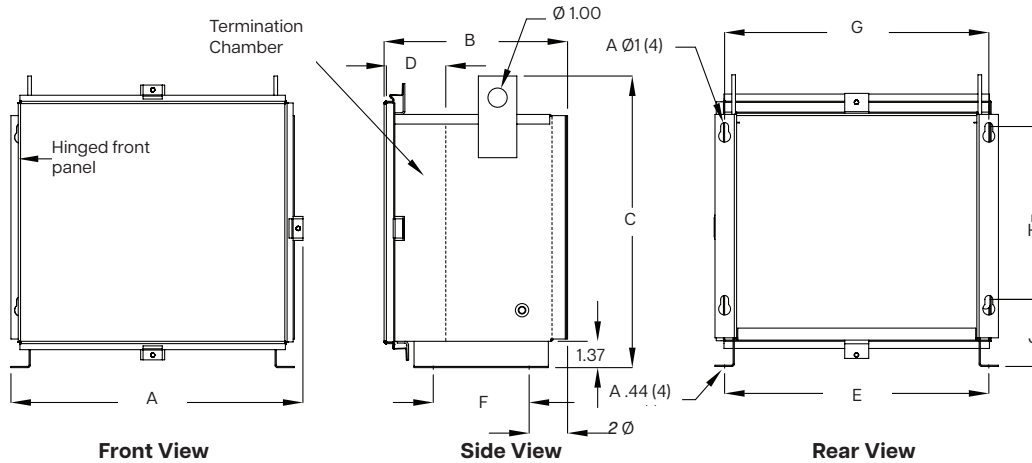
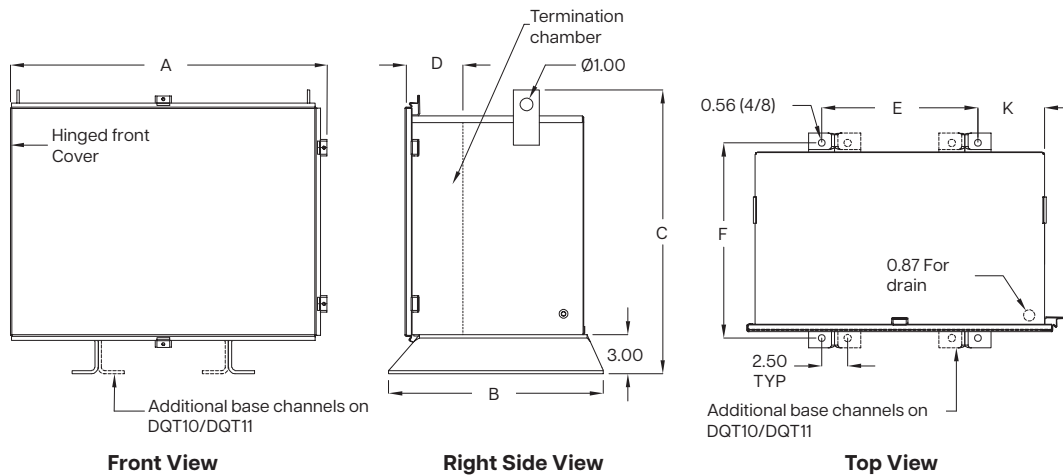

Figure 2



Case Style	Fig. #	Dimensions in Inches [Millimeter]									
		A	B	C	D*	E	F	G	H	J	K
DQT1	1	13.13 [333]	9.13 [232]	13.38 [340]	2.50 [63]	11.50 [292]	5.25 [133]	11.50 [292]	6.50 [165]	3.69 [94]	-
DQT2	1	15.88 [403]	9.88 [251]	15.38 [391]	2.50 [63]	14.25 [362]	6.00 [152]	14.25 [362]	8.00 [203]	3.69 [94]	-
DQT3	1	19.13 [485]	11.88 [302]	14.69 [373]	3.00 [76]	17.50 [444]	8.00 [203]	17.50 [444]	8.00 [203]	3.44 [87]	-
DQT4	1	22.38 [569]	13.88 [352]	17.25 [438]	5.00 [127]	20.75 [527]	10.00 [254]	20.75 [527]	9.00 [229]	3.69 [94]	-
DQT5	2	25.88 [657]	16.50 [419]	21.88 [556]	4.50 [114]	14.00 [356]	15.00 [381]	-	-	-	4.62 [117]
DQT6	2	26.13 [664]	19.75 [501]	21.88 [556]	5.50 [140]	14.00 [356]	18.25 [463]	-	-	-	4.75 [121]
DQT7	2	32.38 [822]	22.00 [559]	25.63 [651]	6.00 [152]	20.00 [508]	20.50 [521]	-	-	-	4.88 [124]
DQT8	2	35.13 [892]	26.00 [660]	26.63 [676]	6.00 [152]	20.00 [508]	24.50 [622]	-	-	-	6.25 [159]
DQT9	2	36.63 [930]	30.75 [781]	25.63 [651]	6.50 [165]	20.00 [508]	29.25 [743]	-	-	-	7.00 [78]
DQT10	2	36.63 [930]	30.50 [775]	31.38 [797]	7.00 [178]	20.50 [521]	29.00 [737]	-	-	-	6.75 [171]
DQT11	2	38.88 [987]	32.25 [819]	33.13 [841]	7.00 [178]	20.50 [521]	30.75 [781]	-	-	-	7.88 [200]

*D represents the typical minimum depth of the termination chamber (conduit fittings should be sized within these limits)

ENCLOSURE DRAWINGS

NQ SERIES - SINGLE PHASE

Figure 1

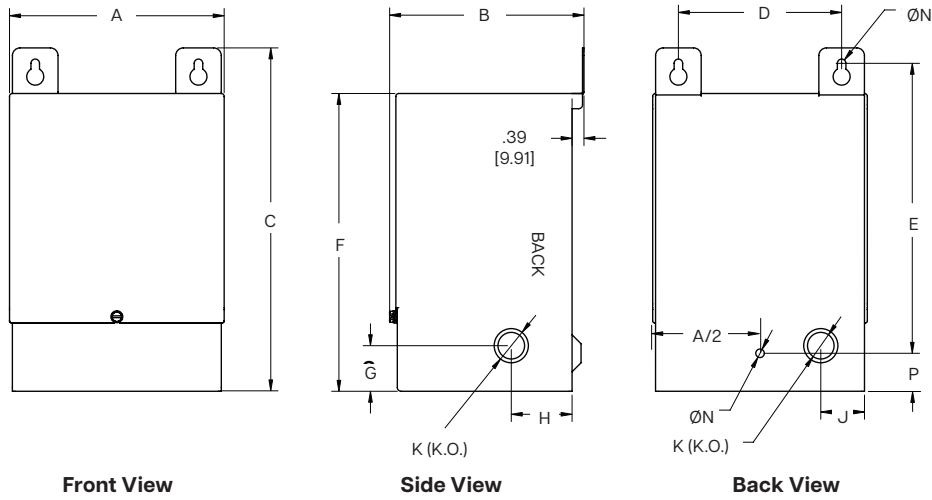
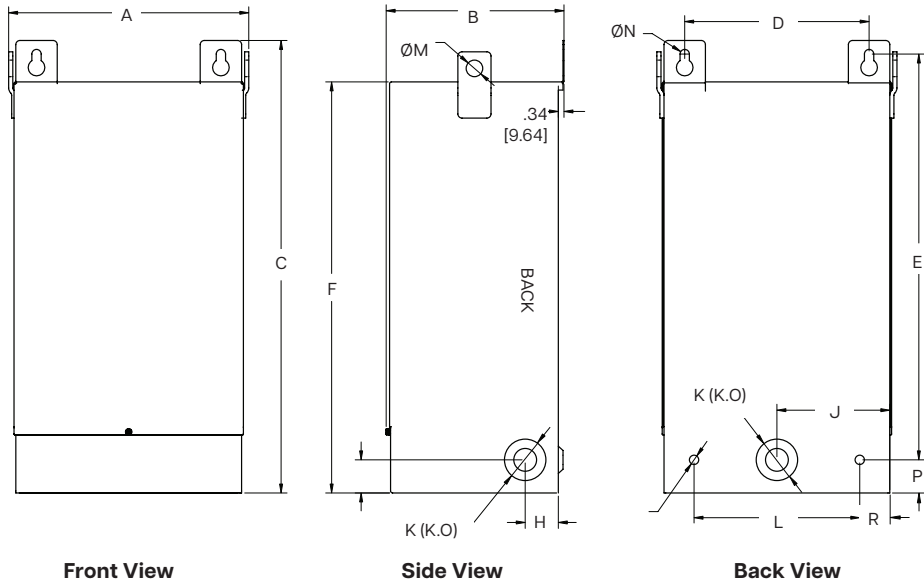

Figure 2



Case Style	Fig #	Dimensions in Inches [Millimeter]														
		A	B	C	D	E	F	G	H	J	K	L	M	N	P	R
NQ0	1	3.69 [93.73]	5.06 [128.53]	7.19 [182.63]	2.50 [63.50]	5.63 [143.01]	6.19 [157.23]	1.50 [38.10]	2.00 [50.80]	--	0.88 [22.36]	--	--	0.22 [5.59]	1.25 [31.75]	--
NQ1	1	4.31 [109.48]	5.56 [141.23]	7.19 [182.63]	3.13 [79.51]	5.63 [143.01]	6.13 [155.71]	1.50 [38.10]	2.00 [50.80]	0.81 [20.58]	0.88 [22.36]	--	--	0.22 [5.59]	1.25 [31.75]	--
NQ2	1	5.06 [128.53]	4.56 [115.83]	9.30 [236.22]	3.88 [98.56]	7.75 [196.85]	8.30 [210.82]	1.50 [38.10]	2.00 [50.80]	1.00 [25.40]	0.88 X 1.13 X 1.38 [22.36 X 28.71 X 35.06]	--	--	0.22 [5.59]	1.25 [31.75]	--
NQ3	1	5.88 [149.36]	5.19 [131.83]	10.56 [268.23]	4.13 [104.91]	8.31 [211.08]	9.06 [230.13]	1.50 [38.10]	2.00 [50.80]	1.25 [31.75]	0.88 X 1.13 X 1.38 [22.36 X 28.71 X 35.07]	--	--	0.28 [7.12]	1.25 [31.75]	--
NQ4	1	7.06 [179.33]	6.25 [158.75]	11.75 [298.45]	5.38 [136.66]	10.00 [254.00]	10.30 [261.62]	1.25 [31.75]	2.00 [50.80]	1.50 [38.10]	0.88 X 1.13 X 1.38 [22.36 X 28.71 X 35.08]	--	--	0.28 [7.12]	1.25 [31.75]	--
NQ5	2	10.00 [254.00]	7.75 [196.85]	17.25 [438.15]	7.38 [187.46]	15.38 [390.66]	15.25 [387.35]	2.38 [60.33]	2.00 [50.80]	4.00 [101.60]	1.13 X 1.38 [28.71 X 35.06]	6.00 [152.40]	0.75 [19.05]	0.44 [11.18]	1.25 [31.75]	1.68 [42.68]
NQ6	2	12.25 [311.15]	9.25 [234.95]	20.88 [530.36]	9.38 [238.26]	18.13 [460.51]	18.88 [479.56]	2.00 [50.80]	2.00 [50.80]	5.00 [127.00]	1.38 X 2.50 [35.06 X 63.5]	8.00 [203.20]	0.75 [19.05]	0.44 [11.18]	2.00 [50.80]	1.68 [42.68]
NQ7	2	14.50 [368.30]	10.75 [273.05]	21.38 [543.06]	11.63 [295.41]	18.63 [473.21]	19.38 [492.26]	2.00 [50.80]	2.00 [50.80]	6.00 [152.40]	1.38 X 2.50 [35.06 X 63.5]	10.00 [254.00]	0.75 [19.05]	0.44 [11.18]	2.00 [50.80]	1.81 [45.98]
NQ8	2	14.50 [368.30]	10.75 [273.05]	27.38 [695.46]	11.13 [282.71]	24.50 [622.30]	24.88 [631.96]	2.00 [50.80]	2.00 [50.80]	6.00 [152.40]	1.38 X 2.50 [35.06 X 63.5]	10.00 [254.00]	0.75 [19.05]	0.56 [14.23]	2.00 [50.80]	1.81 [45.98]

ELECTRICAL SCHEMATICS & CONNECTION DRAWINGS

SCD 1.1

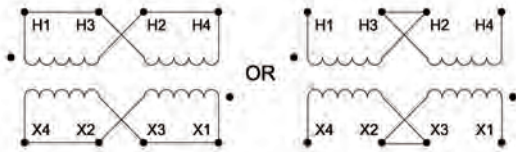

Primary Volts	Connect lines to	Inter-connect
480	H1, H4	1-2
240	H1, H4	2-3
Secondary Volts	Connect lines to	Inter-connect
240	X1, X4	X2-X3
120/240	X1, X2, X4	X2-X3
120	X1, X4	X1-X3, X2-X4

SCD 1.3

Schematic

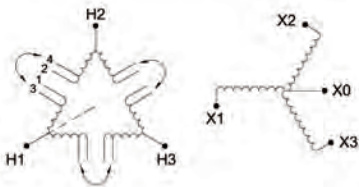

% Voltage	Primary Volts	Connect lines to	Inter-connect
105.0%	504 630	H1, H4	1-2
100.0%	480 600	H1, H2, H3	2-3
95.0%	456 570	H1, H2, H3	3-4
Secondary Volts	Connect lines to	Inter-connect	
208	400	X1, X2, X3	-
120	231	X1, X0 X2, X0 X3, X0	-

SCD 2.1

Schematic

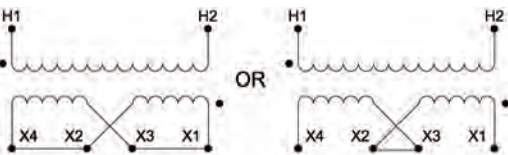

Primary Volts	Connect lines to	Inter-connect
600	H1, H2	-
Secondary Volts	Connect lines to	Inter-connect
240	X1, X4	X2-X3
120/240	X1, X2, X4	X2-X3
120	X1, X4	X1-X3, X2-X4

SCD 2.3

Schematic

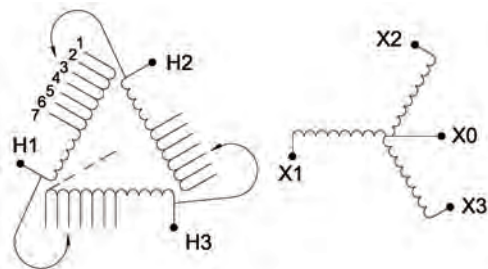

% Voltage	Primary Volts	Connect lines to	Inter-connect
105.0%	504 630	H1, H2, H3	1
102.5%	492 615	H2, H2, H3	2
100.0%	480 600	H1, H2, H3	3
97.5%	468 585	H1, H2, H3	4
95.0%	456 570	H1, H2, H3	5
92.5%	444 556	H1, H2, H3	6
90.0%	432 542	H1, H2, H3	7
Secondary Volts	Connect lines to	Inter-connect	
208	400	X1, X2, X3	-
120	231	X1, X0 X2, X0 X3, X0	-

Tap arrangements shown are for standard products only. May not be applicable for other products.

ELECTRICAL SCHEMATICS & CONNECTION DRAWINGS

SCD 3.1

Schematic

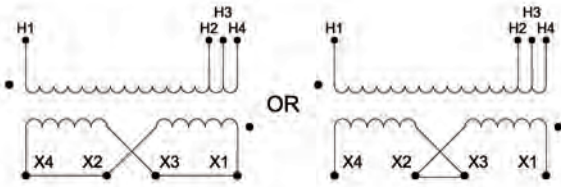

Primary Volts	Connect lines to	Inter-connect
208	H1, H2	-
240	H1, H3	-
277	H1, H4	-
Secondary Volts	Connect lines to	Inter-connect
240	X1, X4	X2-X3
120/240	X1, X2, X4	X2-X3
120	X1, X4	X1-X3, X2-X4

SCD 3.3

Schematic

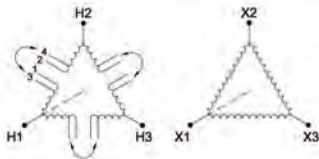

% Voltage	Primary Volts	Connect lines to	Inter-connect
105.0%	504	H1, H2, H3	1-2
100.0%	480	H1, H2, H3	2-3
95.0%	456	H1, H2, H3	3-4
Secondary Volts	Connect lines to	Inter-connect	
240	X1, X2, X3	-	

SCD 4.1

Schematic

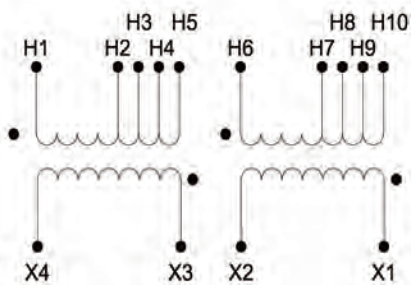

Primary Volts	Connect lines to	Inter-connect
440	H1, H10	H5-H6
416	H1, H9	H4-H6
400	H1, H8	H3-H6
380	H1, H7	H2-H6
220	H1, H10	H1-H6, H5-H10
208	H1, H9	H1-H6, H4-H9
200	H1, H8	H1-H6, H3-H8
190	H1, H7	H1-H6, H2-H7
Secondary Volts	Connect lines to	Inter-connect
240	X1, X4	X2-X3
120/240	X1, X2, X4	X2-X3
120	X1, X4	X2-X4, X1-X3

SCD 4.3

Schematic

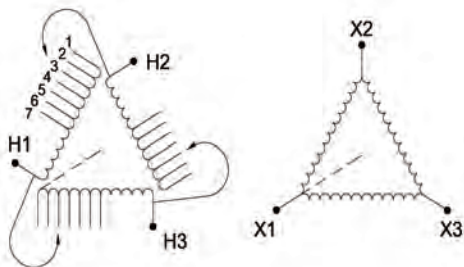

% Voltage	Primary Volts	Connect lines to	Inter-connect
105.0%	504	H1, H2, H3	1
102.5%	492	H1, H2, H3	2
100.0%	480	H1, H2, H3	3
97.5%	468	H1, H2, H3	4
95.0%	456	H1, H2, H3	5
92.5%	444	H1, H2, H3	6
90.0%	432	H1, H2, H3	7
Secondary Volts	Connect lines to	Inter-connect	
240	X1, X2, X3	-	

Tap arrangements shown are for standard products only. May not be applicable for other products.

ELECTRICAL SCHEMATICS & CONNECTION DRAWINGS

SCD 5.1

Schematic

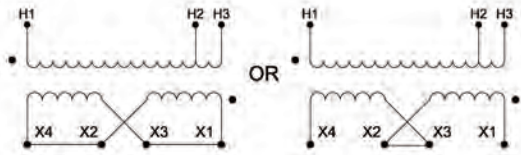

Primary Volts	Connect lines to	Inter-connect
347	H1, H2	-
380	H1, H3	-
Secondary Volts	Connect lines to	Inter-connect
240	X1, X4	X2-X3
120/240	X1, X2, X4	X2-X3
120	X1, X4	X1-X3, X2-X4

SCD 5.3

Schematic

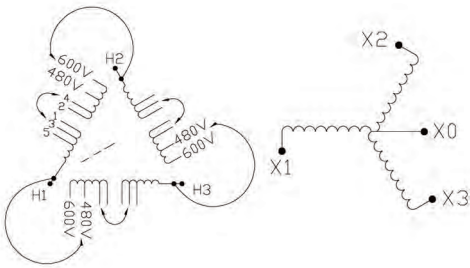

% Voltage	Primary Volts	Connect lines to	Inter-connect
104%	624	600V	1-2 & H1, H2, H3 to 600V
100%	600	600V	2-3 & H1, H2, H3 to 600V
96%	576	600V	3-4 & H1, H2, H3 to 600V
92%	552	600V	4-5 & H1, H2, H3 to 600V
105%	504	480V	1-2 & H1, H2, H3 to 480V
100%	480	480V	2-3 & H1, H2, H3 to 480V
95%	456	480V	3-4 & H1, H2, H3 to 480V
90%	432	480V	4-5 & H1, H2, H3 to 480V
Secondary Volts	Connect lines to	Inter-connect	
480	X1, X2, X3	-	

SCD 6.3

Schematic

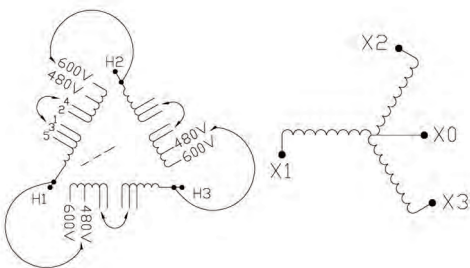

<=75 kVA 115°C, 95°C & 80°C		>=112.5 kVA 115°C, 95°C & 80°C		Connect lines to	Inter-connect
% Voltage	Primary Volts	% Voltage	Primary Volts		
104%	624	103%	624	600V	1-600V
100%	600	100%	600	600V	2-600V
96%	576	96.8%	576	600V	3-600V
92%	552	93.6%	552	600V	4-600V
105%	504	104.5%	504	480V	1-480V
100%	480	100%	480	480V	2-480V
95%	456	95.5%	456	480V	3-480V
90%	432	91.00%	432	480V	4-480V
Secondary Volts	Connect lines to	Inter-connect			
480	X1, X2, X3	-			



CANADA

Hammond Power Solutions

595 Southgate Drive
Guelph, Ontario N1G 3W6
Tel: (519) 822-2441 | Fax: (519) 822-9701
Toll Free: 1-888-798-8882

sales@hammondpowersolutions.com



UNITED STATES

Hammond Power Solutions

1100 Lake Street
Baraboo, Wisconsin 53913-2866
Tel: (608) 356-3921 | Fax: (608) 355-7623
Toll Free: 1-866-705-4684

sales@hammondpowersolutions.com



MEXICO

Hammond Power Solutions Latin America S.

Av. No. 800,
Parque Industrial Guadalupe
Guadalupe, NL, Mexico, C.P. 67190.
Tel: (819) 690-8000

sales@hammondpowersolutions.com



ASIA

Hammond Power Solutions Pvt. Ltd.

Plot No 6A, Phase -1, IDA,
Pashamylaram, Patancheru (M)
Sangareddy, 502 307, India
Tel: +91-994-995-0009

marketing-india@hammondpowersolutions.com

EMEA (SALES OFFICE)

Hammond Power Solutions SpA

Tel: +49 (152) 08800468

sales-emea@hammondpowersolutions.com



hammondpowersolutions.com



TITASP-BBH2-EN
June 2023