



We connect and protect

# Cable Bus Systems

Cost-effective solution with enhanced reliability



CADDY ERICO HOFFMAN ILSCO SCHROFF TRACHTE

[nVent.com](http://nVent.com)

Distributed by Gross Automation | +1 (262) 252-1600 | [sales@grossautomation.com](mailto:sales@grossautomation.com)

## PROVEN TECHNOLOGIES

For over 50 years, nVent has been a trusted leader in the design and manufacture of electrical bus systems. Our cable bus systems provide a reliable, cost-effective alternative to traditional bus duct and cable tray systems—ideal for industrial and commercial power distribution.

Engineered with insulated conductors housed in a rigid, ventilated metal casing, nVent cable bus is built to handle high currents while offering superior ease of installation, low maintenance, and on-site flexibility. It adapts easily to evolving project needs and typically requires less space than multiple runs of tray or conduit.

### Applications

nVent cable bus systems are primarily used for electrical power distribution but can be customized for a range of industries and settings to provide reliable and efficient power delivery:

- Industrial Facilities
- Wastewater Treatment Plants
- Petrochemical Processing
- Oil & Gas Plants
- Pulp & Paper Mills
- Metal Processing Facilities
- Mining Operations
- Data Centers

Whatever your application, nVent delivers tailored solutions to meet your specific power distribution needs.



## PRODUCT BENEFITS

Cable bus is an enclosed power distribution system that uses multiple insulated conductors supported within a rigid enclosure to carry high-capacity electricity. It offers a flexible, cost-effective alternative to traditional bus duct, with advantages in installation, maintenance, and performance.

### Superior Reliability

Each conductor is fully insulated and runs continuously from source to load, minimizing voltage drop and enhancing safety. Housed in a durable enclosure, the conductors are protected while maintaining proper phasing and spacing.

Cable blocks support and separate the conductors, ensuring correct alignment and providing short-circuit protection.

Unlike rigid bus duct, cable bus systems can be easily adjusted in the field to accommodate layout changes or unforeseen obstacles—streamlining installation and reducing labor costs.

With continuous conductors and a robust enclosure, cable bus systems reduce the risk of loose connections and arcing, resulting in lower maintenance requirements.

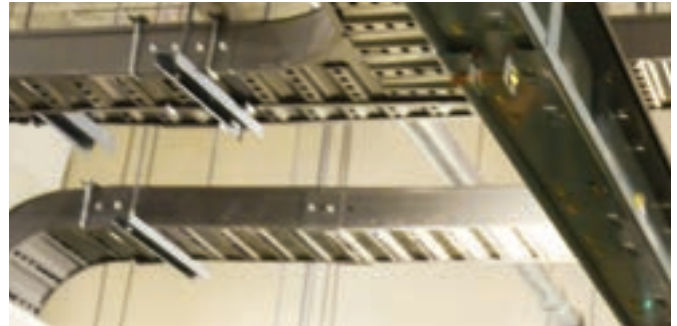

## ENGINEERED CABLE BUS

### System Integration

nVent connect equipment in various configurations—such as switchgear to switchgear, switchgear to transformers, and generators to auxiliary compartments.

To complete the installation, we offer steel supports, fire-rated barriers, bushing boxes, potential transformers, and surge protection cubicles as needed. Along with installation and technical services, nVent provides a completely integrated system from design through installation and commissioning.

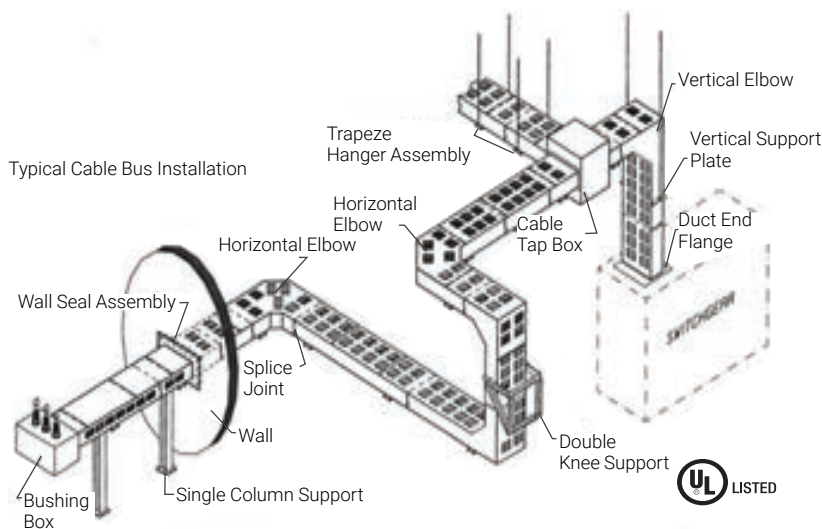

### Integrated System Design

- Rugged Design for Long-Term Reliable Operation
- Low Total Installed Cost
- Complete System Design from the Ground Up
- State-of-the-Art Manufacturing Equipment
- Fluidized Bed Epoxy Insulation System
- Custom Engineered Designs
- Turnkey Projects from Initial Design
- Complete On-Site Service and Parts
- UL Labeled Equipment
- Certified to IEEE and IEC Standards
- Preventative Maintenance Program

## CABLE BUS ELECTRICAL DESIGN

Cable bus is more than just power cable in an enclosure—it's a sophisticated electrical system that can offer cost savings over segregated or non-segregated copper or aluminum bar bus.

1. Supplied with insulated copper or aluminum cable conductors, shielded or unshielded, as required, with or without neutral, and with insulation material per purchaser's requirements. Buses with two or more cables per phase are interleaved for best current balance and lowest impedance.
2. Cable support blocks are molded glass reinforced polyester (fiberglass) for best track resistance, fire resistance and lowest water absorbency. Blocks offer the best weather resistance and dimensional stability.
3. Block sections are bolted together with stainless steel, non-magnetic bolts to provide short circuit strength.
4. Cable support blocks, held in support frames, provide additional short circuit strength. Support blocks and frames, located every 30" along the bus, vary as required by short circuit rating.
5. Bus housing fabricated of extruded aluminum side members (corrosion resistant 6063-T6 alloy) and formed sheet aluminum covers.
6. Indoor bus provided with louvered top and bottom covers. Outdoor bus has louvered side members and bottom covers, with solid top covers. Primed and painted sheet steel housings can be provided if required. Designs are available upon request. Current capacity is approximately 60% of the capacity of the same cables in standard ventilated housing.

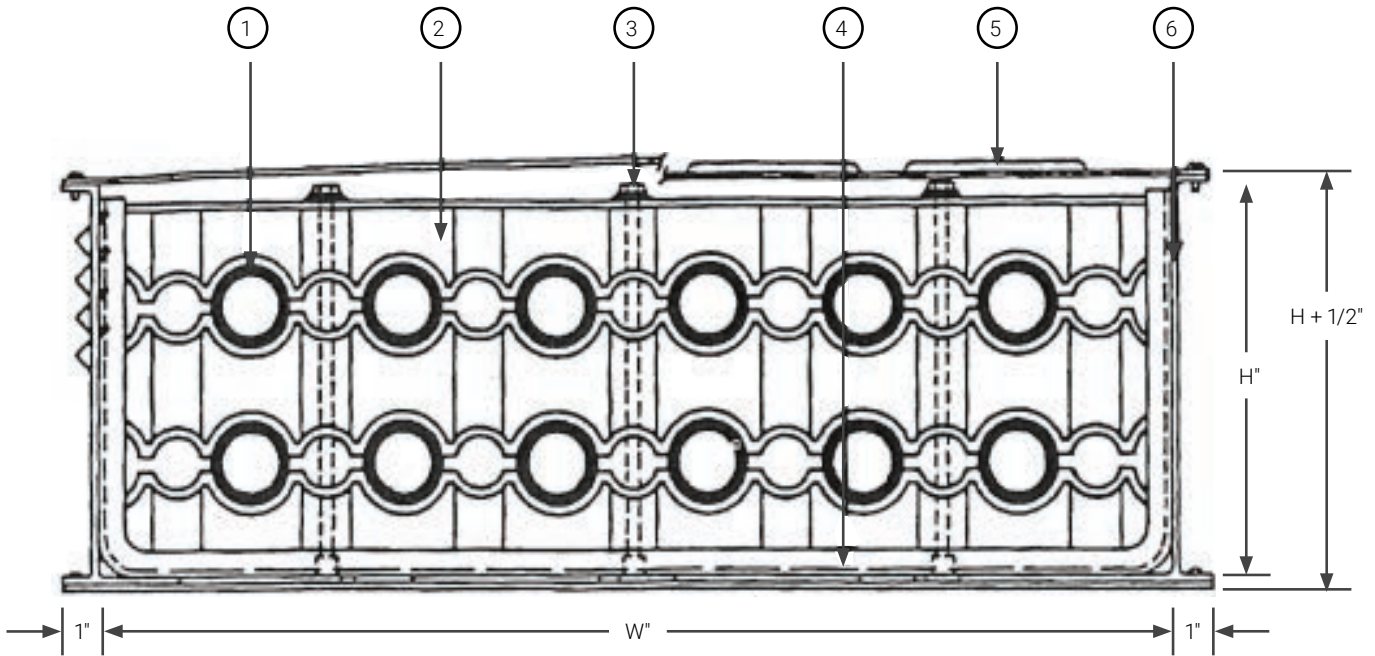

## CABLE RESALE POLICY

nVent supplies cable from various manufacturers based on customer specifications and passes through the manufacturers' sales and warranty policies. nVent will determine the required cable length for each project as follows:

- Overall length is determined by using center line to center line dimensions.
- A 3-foot pigtail is added to each end of the cable to allow for termination assembly and connection to other equipment. The pigtail length can be increased to meet specific customer specification. This will be noted as extra pigtail.
- Depending upon the total cable requirement, various manufacturers have length adjustment policies.
- If the cable is purchased from a cable-stocking distributor, generally there is no special consideration for cut lengths except the charge for cutting and reeling.
- If the cable requirement qualifies for purchase directly from a manufacturer (generally lengths over 2500 feet) then nVent will pass through the manufacturers guaranteed quantity policy. The policy varies from manufacturer to manufacturer, however, for estimating purposes the total requirements may be increased by up to 10%.
- nVent will also delete the cable from the cable bus so the purchaser can provide cable from others sources. In this case, nVent will provide cable interleaving instructions and other relevant engineering data.

- nVent will handle shipping the cable to the job site if we order the cable for the customer. nVent will pass through the shipping policy of the selected manufacturer. Generally, nVent will ship cable directly from the manufacturer to the job site.

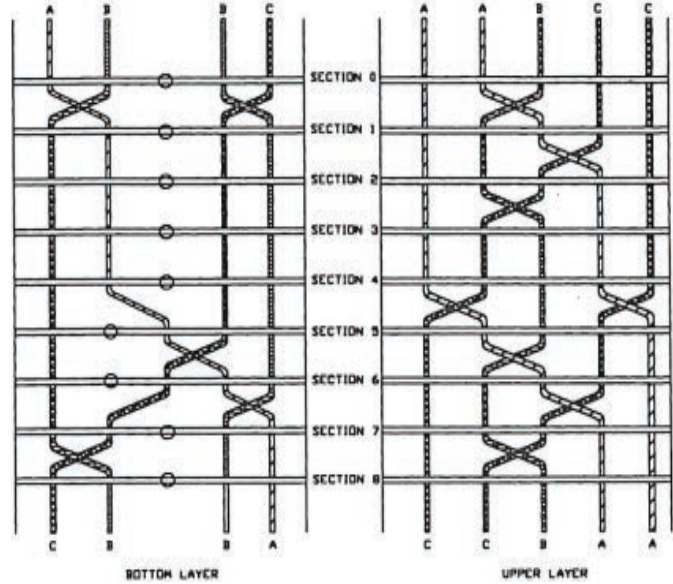

## TECHNICAL INFORMATION

A. Copper conductor, 600 volt, 40°C ambient, 50°C conductor temperature rise, non-shielded, 2 conductors per phase.

**Note:** For outdoor bus, increase the height dimension by 3/4".

Ampacity amperes	ICEA Ampacity amperes	Conductor kcmil	Dimensions H" x W"	Weight lbs.ft
1250	1098	500	6 x 11.5	16
1620	1418	750	8 x 11.5	21
1870	1700	1000	8 x 11.5	17

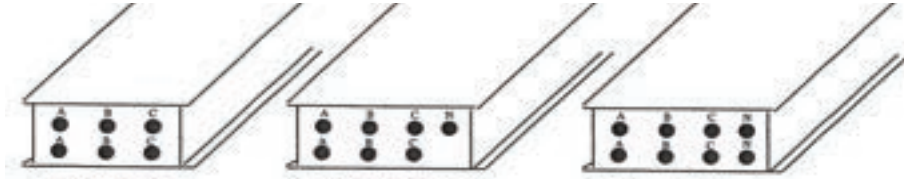

1. 3-Phase, 3-Wire
2. 3-Phase, 4-Wire with 1/2 Neutral
3. 3-Phase, 4-Wire with Full Neutral

B. Copper conductor, 600 volt, 40°C ambient, 50°C conductor temperature rise, non-shielded, 3 conductors per phase.

Ampacity amperes	ICEA Ampacity amperes	Conductor kcmil	Dimensions H" x W"	Weight lbs.ft
2370	2020	750	8 x 19.5	31
2740	2421	1000	8 x 19.5	38

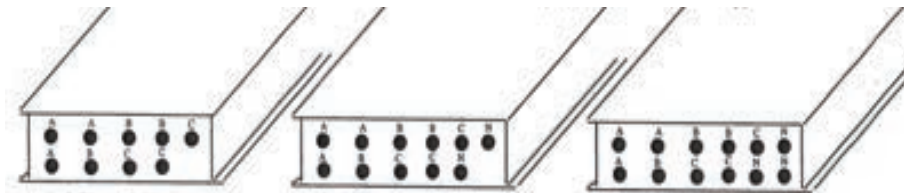

1. 3-Phase, 3-Wire
2. 3-Phase, 4-Wire with 1/2 Neutral
3. 3-Phase, 4-Wire with Full Neutral

C. Copper conductor, 600 volt, 40°C ambient, 50°C conductor temperature rise, non-shielded, 4 conductors per phase.

Ampacity amperes	ICEA Ampacity amperes	Conductor kcmil	Dimensions H" x W"	Weight lbs.ft
3060	2658	750	8 x 23.5	40
3640	3184	1000	8 x 23.5	49

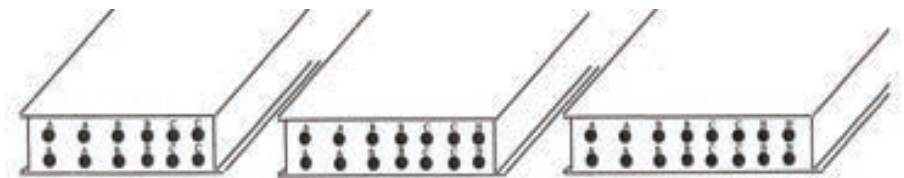

1. 3-Phase, 3-Wire
2. 3-Phase, 4-Wire with 1/2 Neutral
3. 3-Phase, 4-Wire with Full Neutral

D. Copper conductor, 600 volt, 40°C ambient, 50°C conductor temperature rise, non-shielded, 6 conductors per phase.

Ampacity amperes	ICEA Ampacity amperes	Conductor kcmil	Dimensions H" x W"	Weight lbs.ft
4300	3663	750	12 x 24	58
5160	4390	1000	12 x 24	74

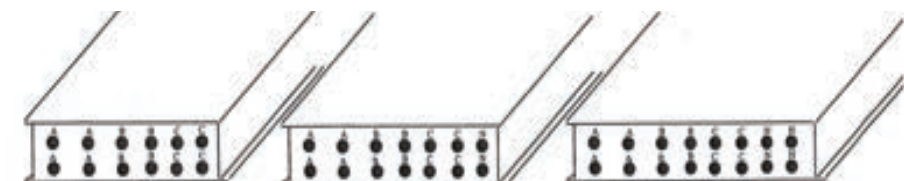

1. 3-Phase, 3-Wire
2. 3-Phase, 4-Wire with 1/2 Neutral
3. 3-Phase, 4-Wire with Full Neutral

E. Copper conductor, 5000 volt, 40°C ambient, 50°C conductor temperature rise, non-shielded, 2 conductors per phase.

Ampacity amperes	ICEA Ampacity amperes	Conductor kcmil	Dimensions H" x W"	Weight lbs.ft
1235	1098	500	8 x 11.5	17
1630	1418	750	8 x 11.5	22
1850	1700	1000	8 x 11.5	28

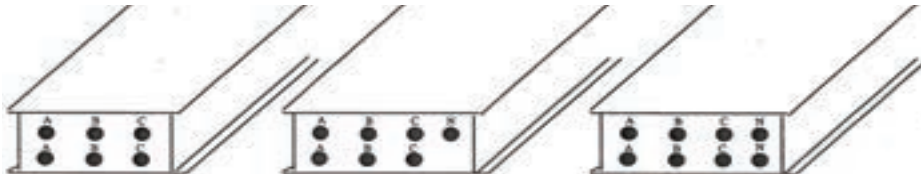

1. 3-Phase, 3-Wire      2. 3-Phase, 4-Wire with 1/2 Neutral      3. 3-Phase, 4-Wire with Full Neutral

F. Copper conductor, 5000 volt, 40°C ambient, 50°C conductor temperature rise, non-shielded, 3 conductors per phase.

Ampacity amperes	ICEA Ampacity amperes	Conductor kcmil	Dimensions H" x W"	Weight lbs.ft
2240	2020	750	8 x 19.5	37
2700	2421	1000	8 x 23.5	41

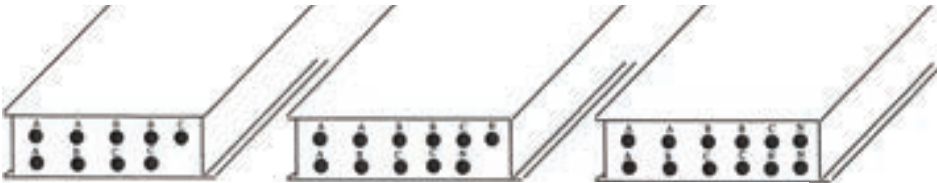

1. 3-Phase, 3-Wire      2. 3-Phase, 4-Wire with 1/2 Neutral      3. 3-Phase, 4-Wire with Full Neutral

G. Copper conductor, 5000 volt, 40°C ambient, 50°C conductor temperature rise, non-shielded, 4 conductors per phase.

Ampacity amperes	ICEA Ampacity amperes	Conductor kcmil	Dimensions H" x W"	Weight lbs.ft
3050	2685	750	8 x 23.5	40
3658	3184	1000	8 x 23.5	49

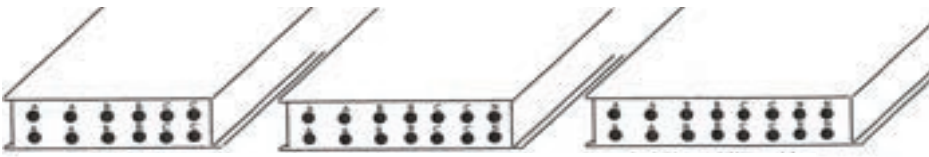

1. 3-Phase, 3-Wire      2. 3-Phase, 4-Wire with 1/2 Neutral      3. 3-Phase, 4-Wire with Full Neutral

H. Copper conductor, 5000 volt, 40°C ambient, 50°C conductor temperature rise, shielded, 2 conductors per phase.

**Note:** Bond shield wires and tie to ground at source end.

Ampacity amperes	ICEA Ampacity amperes	Conductor kcmil	Dimensions H" x W"	Weight lbs.ft
1235	1087	500	8 x 11.5	18
1630	1404	750	8 x 11.5	23
1850	1676	1000	8 x 11.5	28

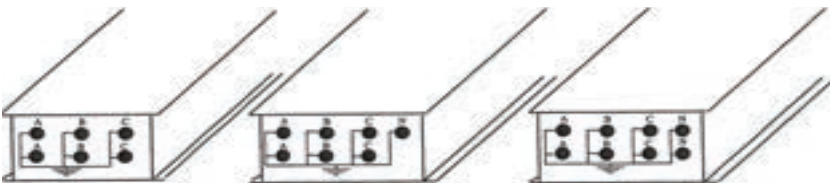

1. 3-Phase, 3-Wire      2. 3-Phase, 4-Wire with 1/2 Neutral      3. 3-Phase, 4-Wire with Full Neutral

- I. Copper conductor, 5000 volt, 40°C ambient, 50°C conductor temperature rise, shielded, 3 conductors per phase.

Ampacity amperes	ICEA Ampacity amperes	Conductor kcmil	Dimensions H" x W"	Weight lbs.ft
2240	2000	750	8 x 19.5	33
2700	2387	1000	8 x 23.5	45

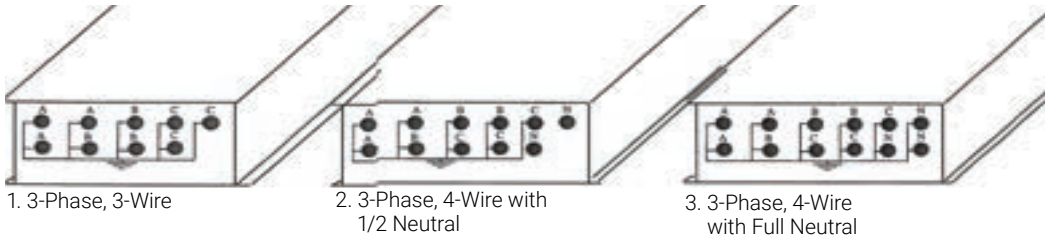

- J. Copper conductor, 5000 volt, 40°C ambient, 50°C conductor temperature rise, shielded, 4 conductors per phase.

Ampacity amperes	ICEA Ampacity amperes	Conductor kcmil	Dimensions H" x W"	Weight lbs.ft
3050	2631	750	8 x 23.5	35
3658	3140	1000	8 x 27.5	59

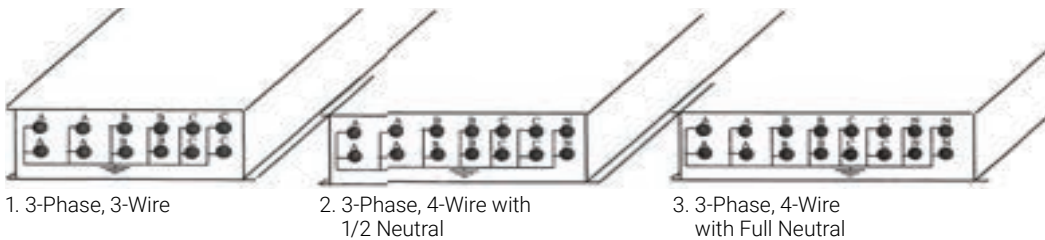

- K. Copper conductor, 15,000 volt, 40°C ambient, 50°C conductor temperature rise, shielded, 2 conductors per phase.

Ampacity amperes	ICEA Ampacity amperes	Conductor kcmil	Dimensions H" x W"	Weight lbs.ft
1220	1071	500	8 x 11.5	20
1600	1377	750	8 x 15.5	26
1820	1643	1000	8 x 15.5	33

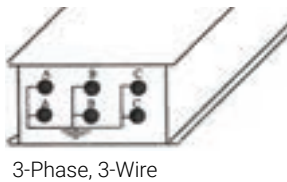

- L. Copper conductor, 15,000 volt, 40°C ambient, 50°C conductor temperature rise, shielded, 3 conductors per phase.

Ampacity amperes	ICEA Ampacity amperes	Conductor kcmil	Dimensions H" x W"	Weight lbs.ft
2200	1962	750	8 x 23.5	37
2650	2340	1000	10 x 28	64

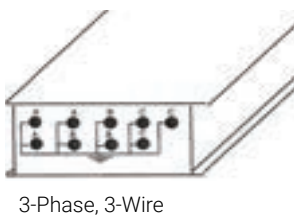

M. Copper conductor, 15,000 volt, 40°C ambient, 50°C conductor temperature rise, shielded, 4 conductors per phase.

Ampacity amperes	ICEA Ampacity amperes	Conductor kcmil	Dimensions H" x W"	Weight lbs.ft
3000	2581	750	8 x 27.5	49
3620	3078	1000	10 x 28	62

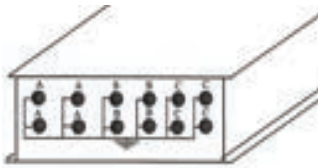

3-Phase, 3-Wire

## ROOF ENTRANCE SEAL

1. After the conductors are threaded through the seal plate and properly secured by the conductor supports, apply a generous amount of Kearney Aqua Seal Compound around each conductor. Be sure to pack compound tightly into the seal plate.
2. This seal may become loose in transit or during installation. After the cable terminals are bolted in place, the seal should be inspected to make sure that the Aqua Seal is properly packed.
3. (Field Applied) Properly mix the sealing kit, (#85 Flexane Compound) furnished by nVent. Pour compound into nest until flush with top 1/2" GPO-3 Fiberglass.

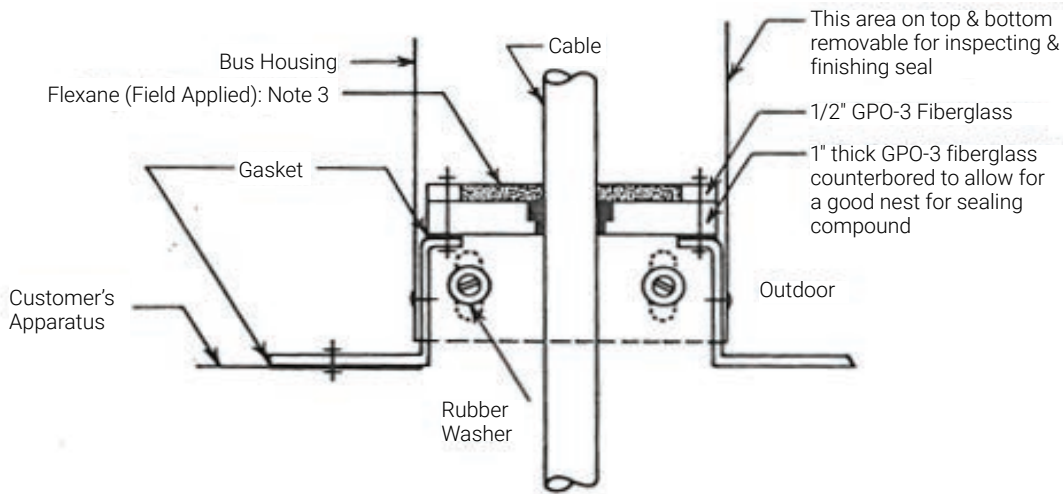

# TYPICAL CABLE TERMINATION DETAILS

## 600 Volt Indoor Termination

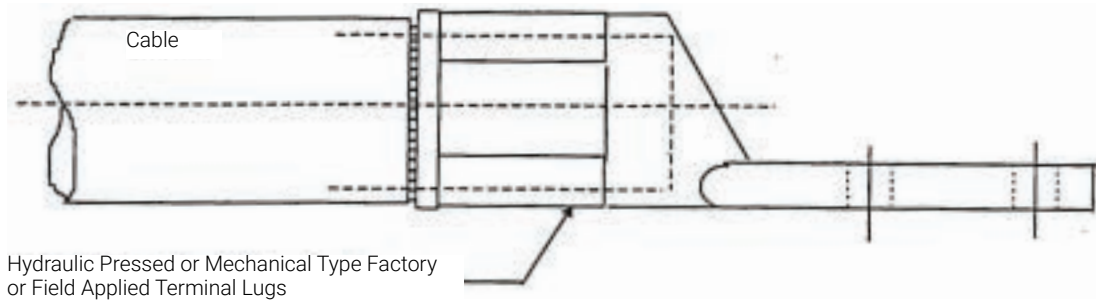

## 600 Volt Outdoor and 5000 Volt Indoor or Outdoor Termination

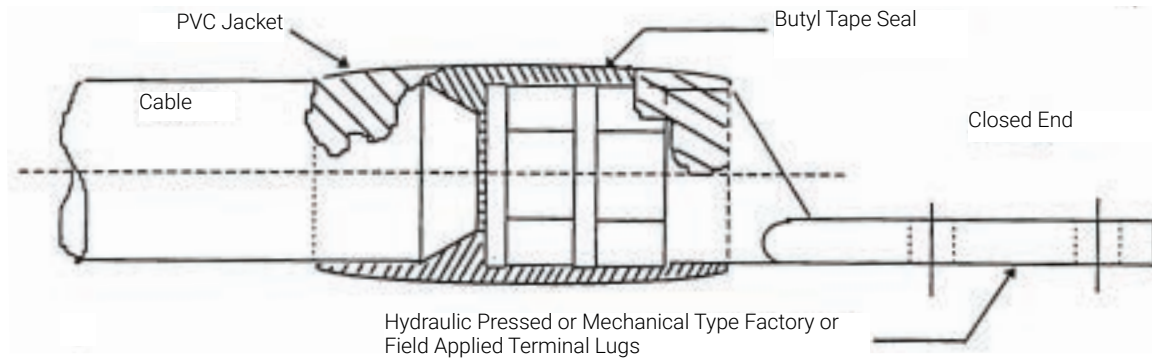

## 15,000 Volt Termination

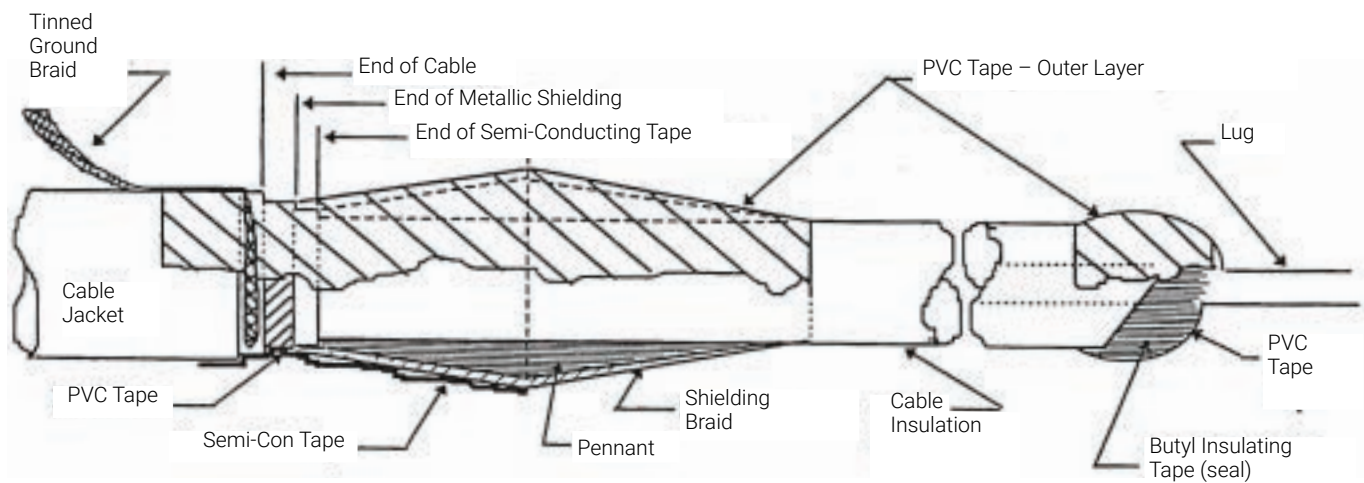

# CABLE BUS WALL SEAL ASSEMBLY

## Choice of Materials

- Wall Throat – 3.5" x 2.5" x 0.25" Angle (Al. or Stl.)
- Wall Plate – 0.1875" Thick Al. or Stl.
- Seal Plate – 1" Thick Benelex or Fiberglass
- Gasketing – Neoprene

A temporary cover plate is supplied for a wall throat when throat is shipped in advance of bus.

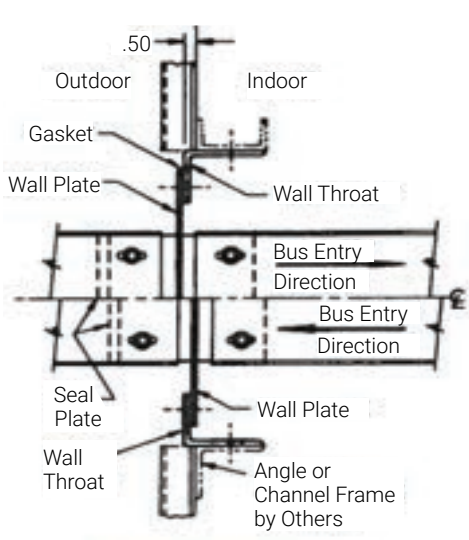
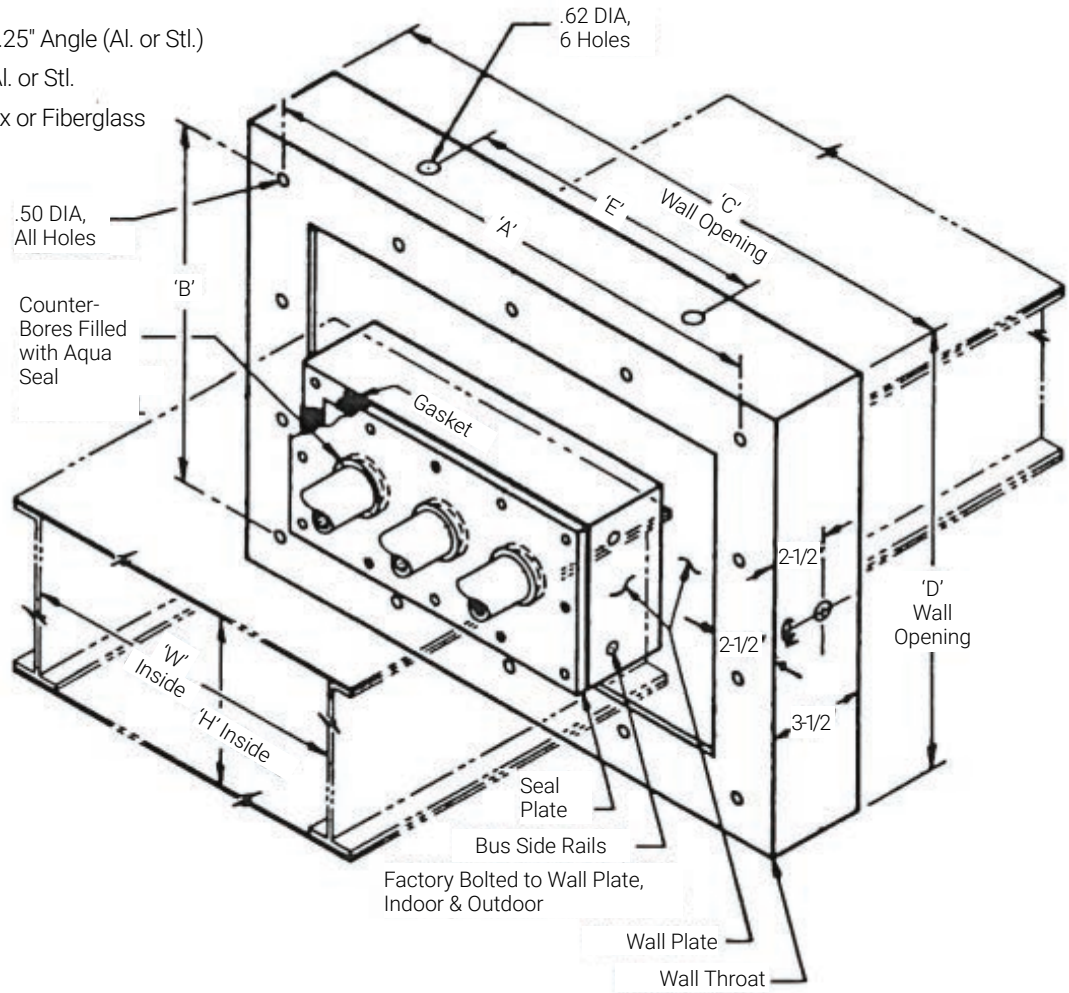

**Corrugated Type Wall**

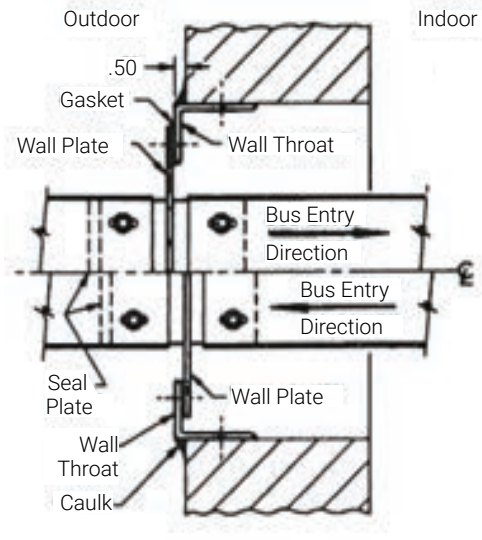

**Masonry Wall**

## NVENT INSTALLATION & SERVICE

### Tap the Industry Experts to Ensure Optimal Performance of Your Bus System

With over 50 years of experience, nVent is a leader in the design and manufacture of isolated phase, segregated phase, and non-segregated phase bus systems. Our deep expertise allows us to service and maintain systems from any manufacturer.

From power generation to industrial and nuclear facilities, nVent ensures your bus system is installed and maintained for peak performance. As your single-source contractor, we manage every step—from initial design through manufacturing to final installation—adhering to owner preferences and all applicable U.S. or international standards.

### Comprehensive Parts Support

Whether you need stock or custom parts, nVent delivers. We supply flexible connectors, fabricated copper and aluminum parts, tapes, insulators, insulating boots, termination kits, hardware, sealants, and more—fast.



### 24/7 Emergency Support

nVent field representatives are on-call around the clock, with response capability within one hour and global on-site support as quickly as travel allows. Most repairs can be completed during the initial visit, with custom or replacement parts typically shipped within 24 hours—and many stock parts available for same-day shipping.

**Contact nVent for all your installation, service, and parts needs.**



Our powerful portfolio of brands:

**CADDY ERICO HOFFMAN ILSCO SCHROFF TRACHTE**