



**CONNECT AND PROTECT**

# Baying and lifting

Whitepaper



**HOFFMAN**



## Table of contents

Introduction .....	4
<b>Enclosures baying</b>	
<b>Floor standing enclosures</b>	
<b>Side to side baying</b> .....	<b>8</b>
Internal baying brackets .....	8
External baying brackets .....	12
Corner baying kit .....	16
Internal separation   Separation plate.....	22
Continuous mounting   Filler plate .....	24
Continuous mounting   Wide mounting plate .....	25
<b>Back to back baying</b> .....	<b>26</b>
Depth baying kit .....	26
Internal separation   Mounting plate.....	30
Internal separation   Partial mounting plate .....	31
<b>Corner baying</b> .....	<b>34</b>
Depth baying kit.....	34
Internal separation   Separation plate.....	38
Internal separation   Side mounting plate .....	39
<b>Wall mounted enclosures</b>	
<b>Side to side baying</b>   Wall mounted combining kit .....	44
<b>Top to bottom baying</b>   Gland plate combining gaskets .....	50
<b>Enclosures lifting</b>	
<b>Floor standing enclosures</b>	
<b>Stand alone enclosures</b> .....	<b>60</b>
Lifting eye bolts .....	60
Lifting kit .....	64
<b>Side to side bayed</b> .....	<b>68</b>
Lifting eye bolts.....	68
Lifting device .....	72
<b>Back to back bayed</b> .....	<b>76</b>
<b>Cornered bayed</b> .....	<b>78</b>
<b>Wall mounted enclosures</b>	
Single enclosure   Lifting eyes .....	80



## Introduction

This white paper has been prepared and created by nVent HOFFMAN to support customers with information on how to lift and bay enclosures. nVent HOFFMAN also want to support customers in being able to make the best buying and lifting choices for enclosures based on their requirements as well as site limitations.

nVent HOFFMAN's wall mounted and floor standing enclosures are continuously changing to meet demanding requirements customers and the engineering industry desire, which includes installation in a wide range of environments, accessory compatibility, ease of installation and to limit damage where possible.

nVent HOFFMAN not only supply high quality enclosures to meet stringent industrial requirements but also offer a wide range in supporting documentation such as this white paper, to provide the technical information needed for supporting customers and to make their job as easy as possible.

nVent HOFFMAN ensure that its enclosures are tested to the strictest of standards by highly recognized independent testing laboratories. Certifications are published on nVent HOFFMAN's websites which provides confidence to customers when using enclosures, peripherals and accessories.

The internationally recognized IEC EN 62208 standard stipulates all of the requirements that need to be met with regards to enclosures that are used in low-voltage switchgear and control gear assemblies. In compliance to the standard nVent HOFFMAN have provided a series of white papers to make all necessary information easily available and interpretable by its direct and in-direct customers.

nVent HOFFMAN's wall mounted and floor standing enclosures are tested for loading and lifting capabilities in accordance with IEC EN 62208. Within this test the enclosures are loaded to a specific weight, lifted and moved several times to ensure that the enclosures are still functional and in good quality.

Enclosure installations are deemed to be as difficult as the installation site permits. Due to the pressures of the industrial market, it is paramount that installations are carried out in an efficient and effective way meaning the installation time is as low as possible while ensuring health and safety is always taken into consideration.

Measurements are displayed in millimeters (mm) and loads are given in Newton's (N) as a display of force. The formula to work out a force is shown below along with a conversion to the kilogram (Kg).

Force (N) = mass (Kg) x acceleration (m/s<sup>2</sup>)

Acceleration due to gravity is measured at 9.8m/s<sup>2</sup> and occurs when an object is falling to the earth.

1 N is a force of 1 with acceleration due to gravity with means from the above formula that the below applies when converting from Force (N) to mass (Kg).

1 Kilo = 9,81 N

To convert the loads in this white paper to kilo: Newton / 9.81.

### General notes

This white paper and all technical descriptions regarding nVent HOFFMAN's enclosures do not represent warranted qualities and therefore nVent HOFFMAN are unable to accept liability with regard to deviations.

nVent HOFFMAN reserves the right to extend or modify this technical documentation at any time.

All of the technical information contained within this white paper is applicable to nVent HOFFMAN's enclosures only.

For any questions or suggestions with regards to this technical white paper please do not hesitate to contact your local sales representative or partner.

# Enclosures baying

nVent HOFFMAN's enclosures can be bayed together to create larger enclosure configurations. nVent HOFFMAN's floor standing enclosures support baying in all directions as well as in two axes for wall mounted enclosures. This is thanks to the innovative profile system.

Bayed enclosure configurations are perfect systems where there is a requirement for multiple operations that require segregation due to ingress protection (i.e. power distribution) or due to the enclosures having both inputs and outputs (i.e. field signals and automation).

nVent HOFFMAN complements all baying configurations with an array of accessories. The required accessories depend on how the enclosures are bayed together, the enclosure's material and the installation environment. Baying accessories should be used to enhance the enclosure's strength, rigidity and to not deteriorate the enclosure's ingress and impact protection ratings.



## Common configurations

### Floor standing enclosures



#### Side to side baying

Conventional baying solution that is deemed very popular in the automotive and processing industries. This configuration is used both for automation and for power distribution. The number of enclosures bayed side to side can be infinite depending on customers' requirements.



#### Back to back baying

Accessible configuration to ensure operators have access to both doors on the enclosures. As the enclosures are usable from both sides, this configuration is very useful when enclosures are mounted in the center of its environment (i.e. data centers and control rooms). Perfect solution for confined spaces.



#### Corner baying

When there is limited installation space, corner baying configurations are ideal. These configurations are often used in mechanical engineering plants.

### Wall mounted enclosures



#### Side to side baying

Conventional baying solution that is deemed very popular in the automotive and processing industries. This configuration is used both for automation and for power distribution. The number of enclosures bayed side to side can be infinite depending on customers' requirements.



#### Top to bottom baying

When there is limited installation space, corner baying configurations are ideal. These configurations are often used in mechanical engineering plants.

## Internal baying brackets | CCI06

### Description:

Internal baying brackets provide a rigid reinforcement of the enclosure assembly. The correct spacing between the enclosures is assured. Internal baying brackets are installed using click-in fixation points dramatically reducing the required installation time. To remove the click-in baying brackets a quarter turn from a cross head screwdriver is required.

### Enclosure compatibility:

Floor standing combinable enclosures:  
MCS, MCD, MCSS, MCDS, ECOM

### Installation:

nVent HOFFMAN's standard side to side enclosure configurations are bayed using six internal baying brackets, three individually spaced down each vertical profile along with an internal corner baying kit.

### Limitations:

Internal baying brackets cannot be used if a separation plate, SPD, is required.

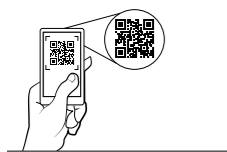

## Mounting instructions

### Mounting

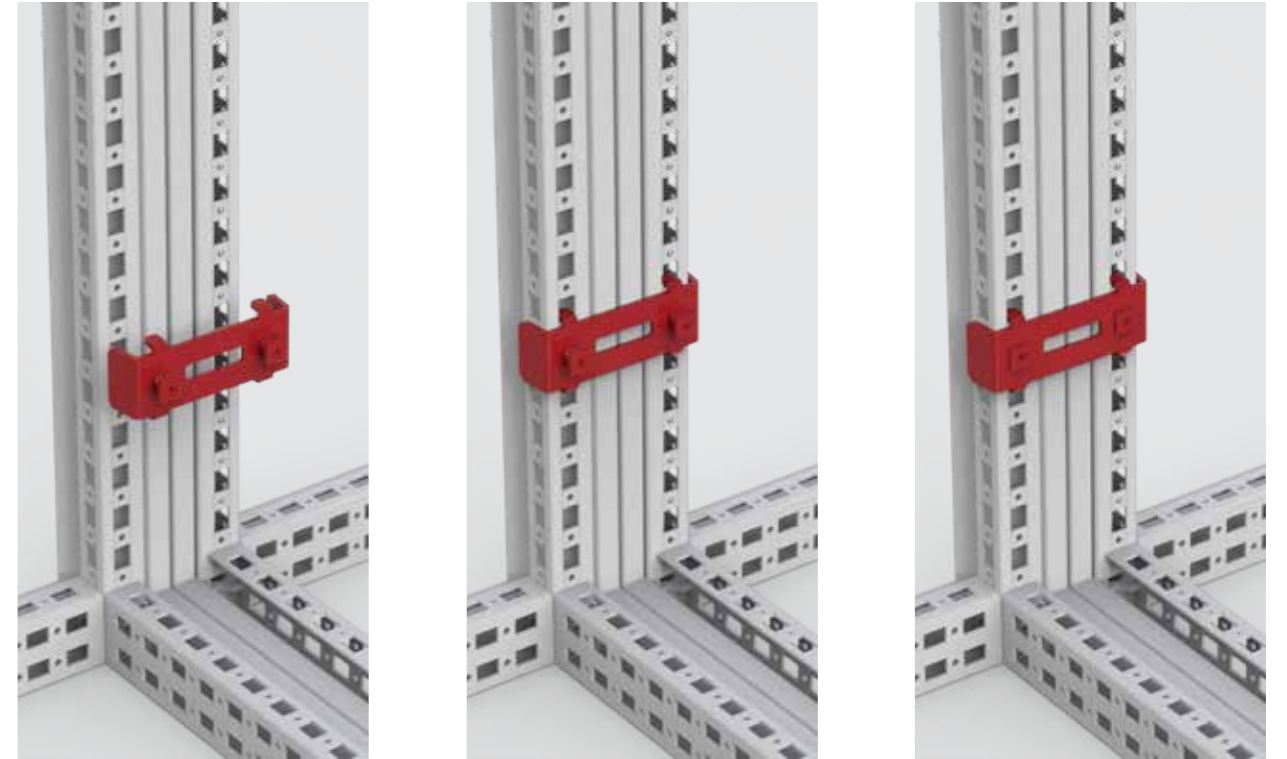

### Demounting

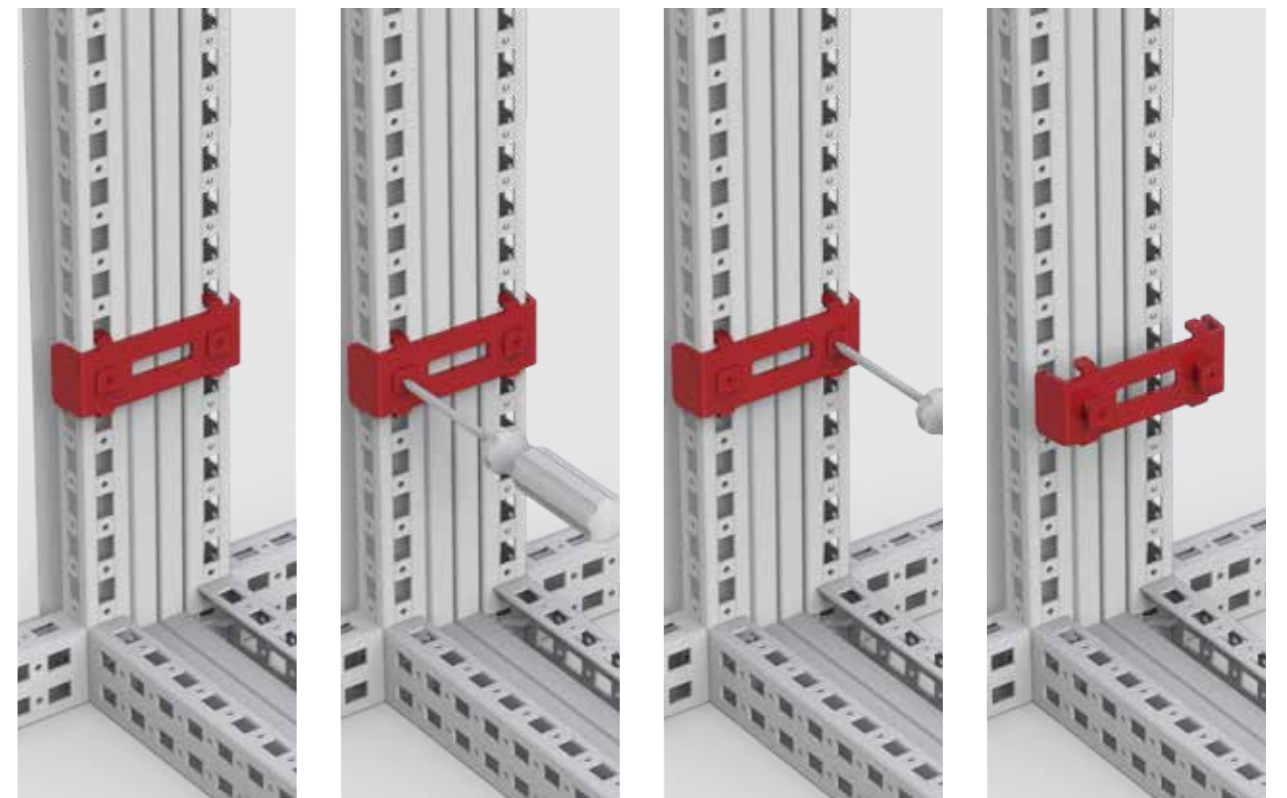

**Application**

Baying brackets should be used when an enclosure needs to be bayed next to another to extend the internal space for the installation of components, switchgear and other electrical devices. As explained, nVent HOFFMAN provides three different types of baying brackets/kits for baying enclosures side to side: internal baying brackets CCI, external baying brackets CCE, and internal corner baying brackets.

The internal baying brackets should be used to bay enclosures side to side to maintain a degree of ingress protection.



## External baying brackets | CCE06

### Description:

External baying brackets are mounted on the outside hole pattern of the frame ensuring strong 3-dimensional alignment of the bayed enclosures with an "auto spacer" function. This method of baying enclosures also has an advantage due to its direct earthing connection between the enclosure frames. Short external baying brackets (CCEH06) are available when small partial doors and/or panels are used.

### Enclosure compatibility:

Floor standing combinable enclosures MCS, MCD Installation: nVent HOFFMAN's standard side to side enclosure configurations can be bayed using six external baying brackets, three individually spaced down each vertical profile.

### Limitations:

External baying brackets cannot be installed on stainless steel enclosures.



## Mounting instructions

### Mounting

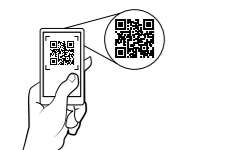

**Application**

Baying brackets should be used when an enclosure needs to be bayed next to another to extend the internal space for the installation of components, switchgear and other electrical devices. As explained, nVent HOFFMAN provides three different types of baying brackets/kits for baying enclosures side to side: internal baying brackets CCI, external baying brackets CCE, and internal corner baying brackets.

External baying brackets will be used when it is not possible to use internal baying brackets, i.e., when a separation plate is installed between bayed enclosures or between small partial doors/panels.



## Corner baying kit | CCM04

### Description:

Internal corner baying brackets provide extra support when bayed enclosures are fully equipped and require lifting. The internal corner baying kit fixes to enclosures using the existing profile hole pattern with snap-lines. Can be installed together with the separation plate, SPD.

### Enclosure compatibility:

Floor standing combinable enclosures  
MCS, MCD, MCSS, MCDS, ECOM

### Installation:

nVent HOFFMAN's standard side to side enclosure configurations are bayed using four internal corner baying brackets, one installed in each corner of the bayed enclosures along with internal baying brackets.

### Limitations:

When the separation plate, SPD, is installed installation access is limited. It is best practice to install the corner baying brackets first.

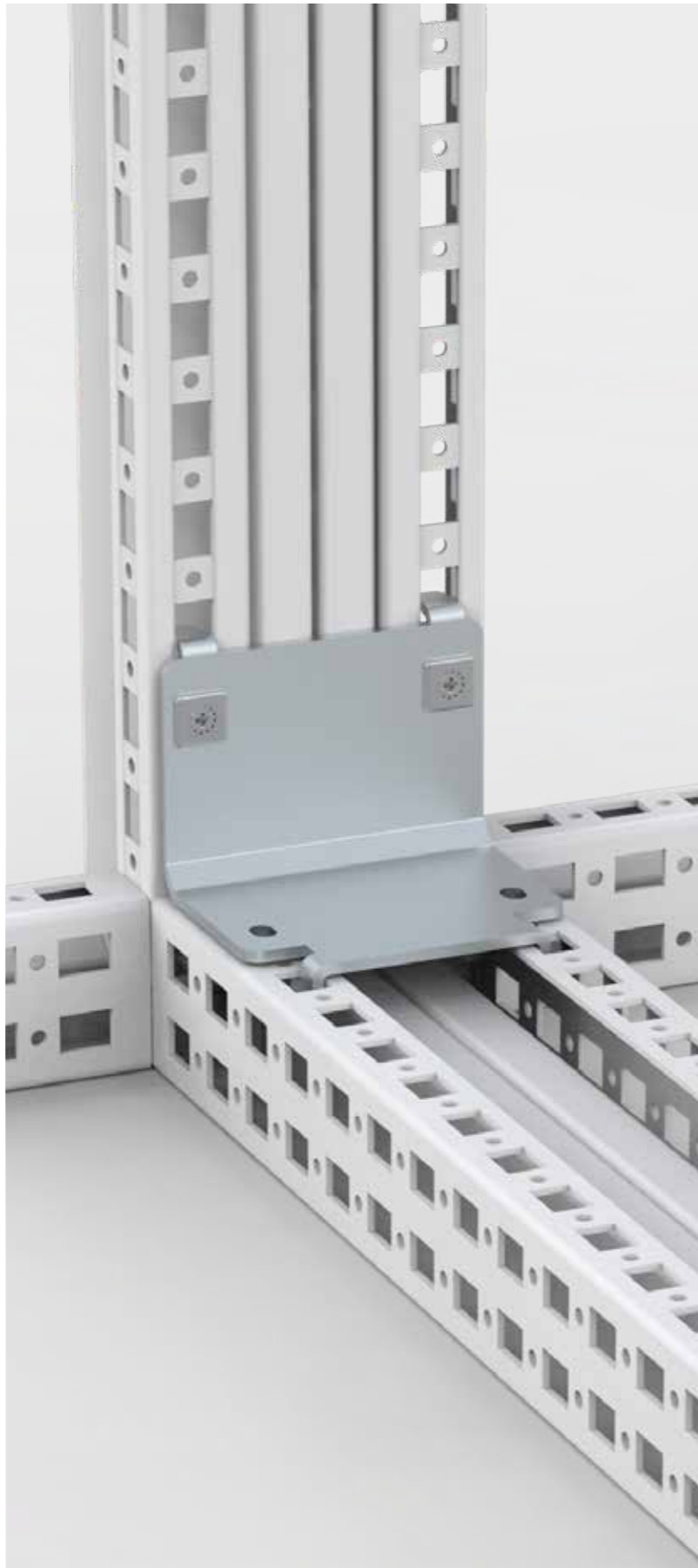

## Mounting instructions

### Mounting

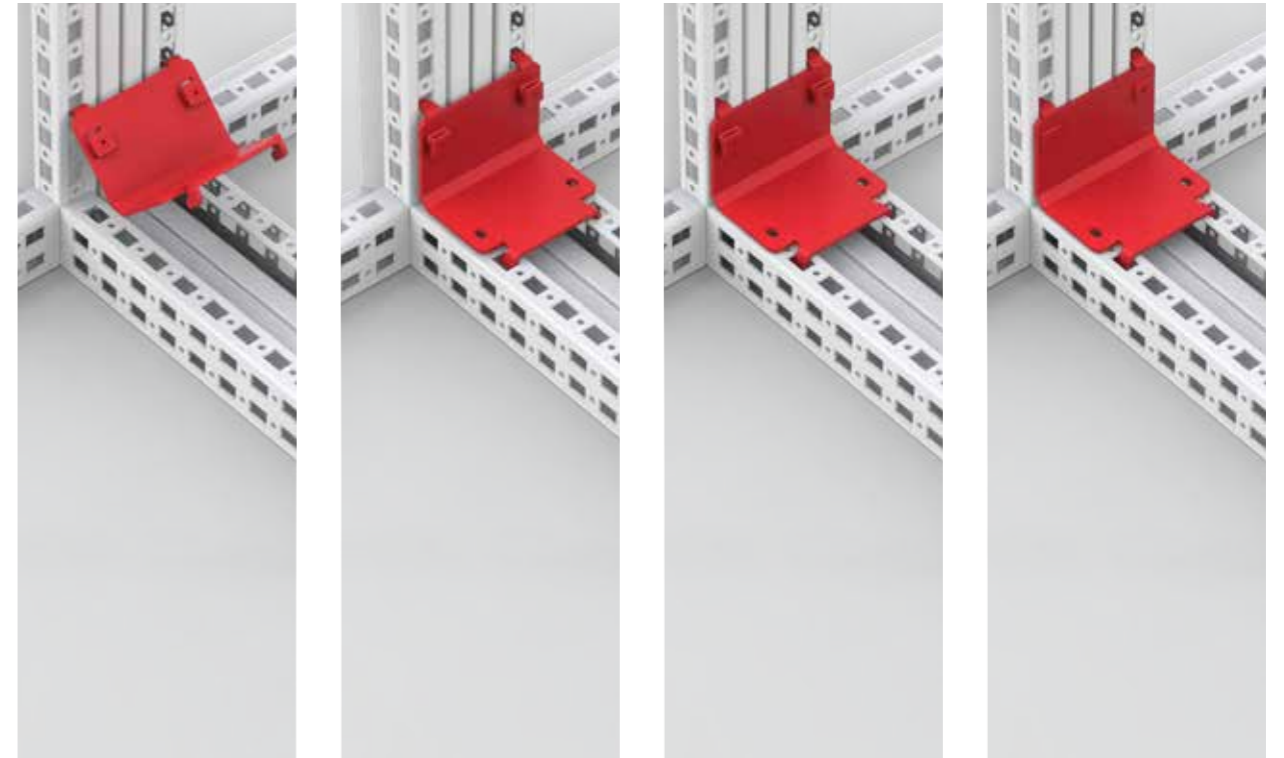

### Demounting

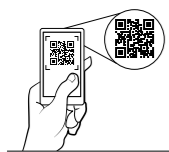
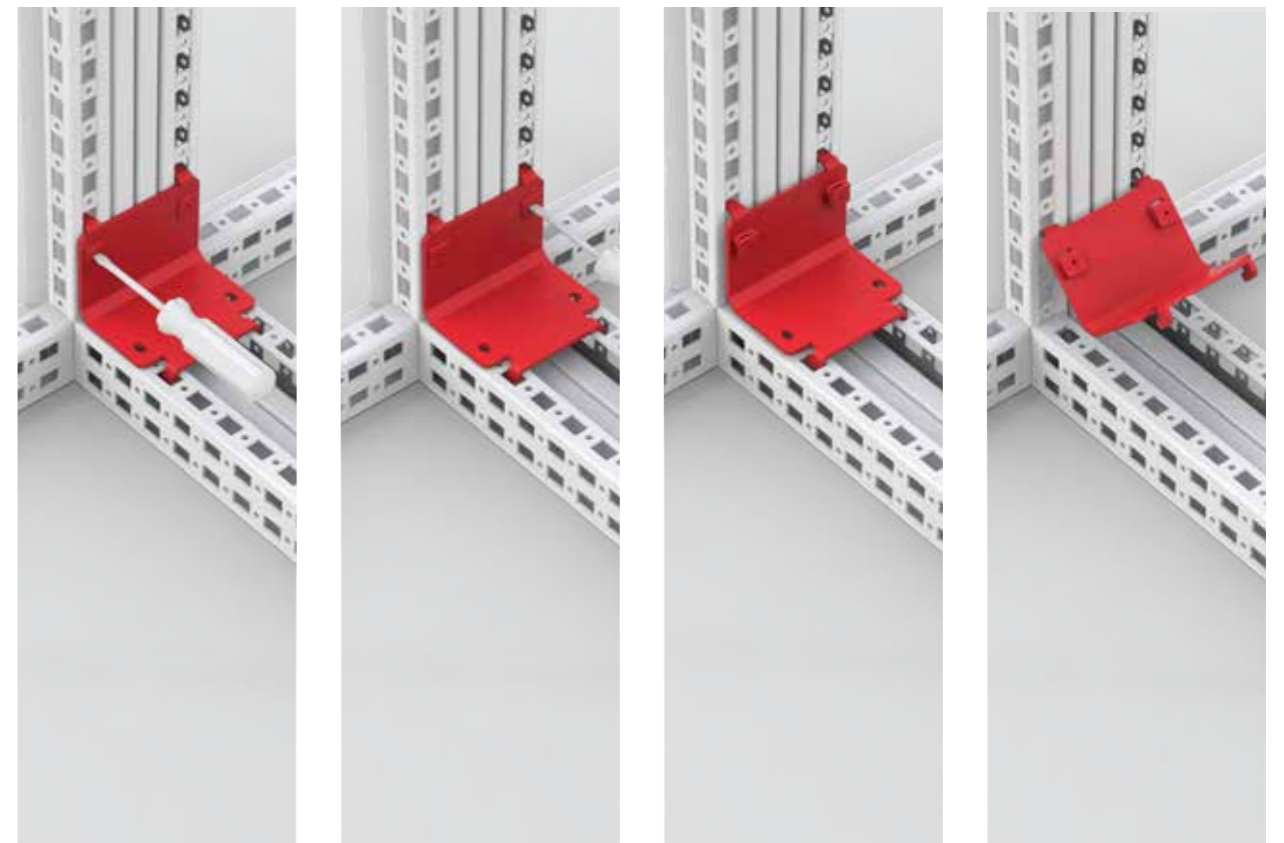

**Application**

Baying brackets should be used when an enclosure needs to be bayed next to another to extend the internal space for the installation of components, switchgear and other electrical devices. As explained, nVent HOFFMAN provides three different types of baying brackets/kits for baying enclosures side to side: (why colon?)

External baying brackets will be used when it is not possible to use internal baying brackets, i.e., when a separation plate is installed between bayed enclosures or between small partial doors/panels.





### Internal separation

## Separation plate | SPD

#### Description:

The internal space of the side to side combined enclosures can be divided using nVent HOFFMAN's internal separation panel, gasket and brackets.

#### Required accessories:

Separation plate brackets, CCJ06

Separation plate gasket, SPDG01  
(To be used if IP43 is required)

Separation plate EMI gasket, SPDEG01 (To be used if EMC shielding is required in place of SPDG01)

#### Limitations:

Cannot be used in conjunction with nVent HOFFMAN's internal baying brackets (CCI). External baying brackets (CCE) and/or a corner baying kit (CCM) should be used instead.

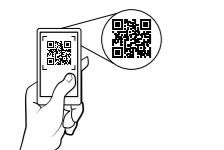
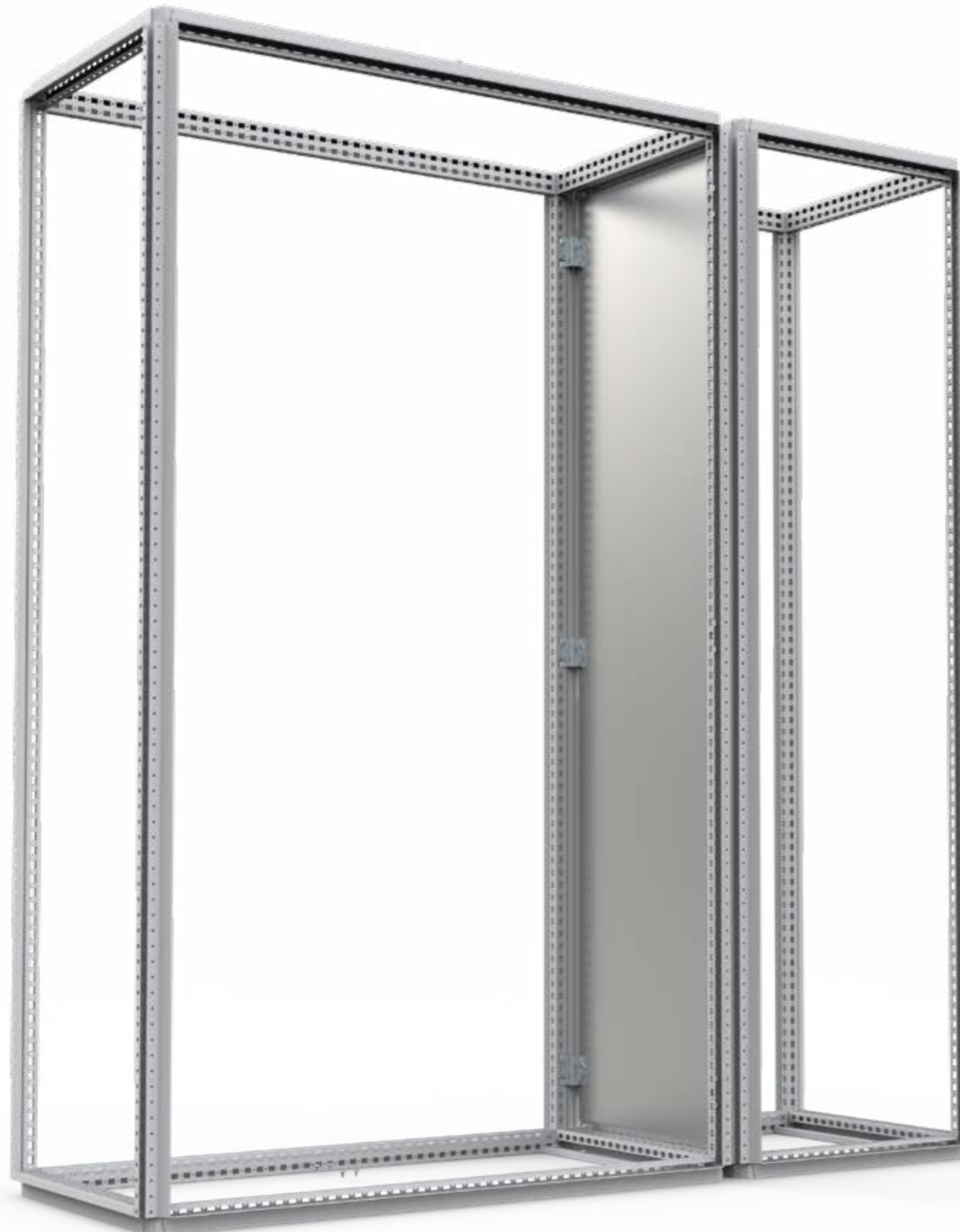

Continuous mounting

Filler plate | MPF

Description:

To maximise the amount of available mounting space on the enclosure's mounting plate when combinable enclosures are bayed, additional and alternative accessories can be used.

Required accessories:

N / A

Limitations:

Mounting plates cannot be installed in the enclosure's rearmost position.

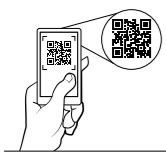

Continuous mounting

Wide mounting plate | MPW

Required accessories:

Transversal sliding profile, MTS.

Limitations:

Mounting plates cannot be installed in the enclosure's rearmost position.



## Depth baying kit | CJDN

### Description:

Depth baying kits allow combinable floor standing enclosures to be bayed back to back. The enclosures' rear profiles provide the correct spacing between the enclosures. The spacing is covered by a plate provided in the baying kit. The baying kit allows for deep components to be installed along with access from both sides. Depth baying kits are delivered with a gasket as well as mounting accessories that maintain an ingress protection rating of 55.

### Enclosure compatibility:

Floor standing combinable enclosures:  
MCS, MCD  
(MCSS, MCDS available on request)

### Installation:

nVent HOFFMAN's standard back to back enclosure configurations are bayed using eight internal baying brackets, three individually spaced down each vertical profile and one in the middle of the bottom/top profiles. A gasket is placed between both enclosures to guarantee the IP rating and the configuration is finished with blanking plates to ensure a continuous smooth surface when side panels (SPM) are installed (side panels are not supplied in the depth baying kit).

### Limitations:

Standard depth baying kit cannot be installed on stainless steel enclosures.



## Mounting instructions



**Application**

Depth baying kits should be used when an enclosure needs to be bayed back to back to another to extend the depth for the installation of components, switchgear and other electrical devices. The depth baying kit can also be used if access to both sides of the enclosure solution is required.

Enclosure configurations should not be transported or lifted using the depth baying kit. To transport or lift enclosures bayed back to back it is essential that they are separated first and transported as individual enclosures



### Internal separation

## Mounting plate | MP

#### Description:

If enclosure segregation is required then a full height mounting plate, MP, with brackets can be used. Partial height mounting plates, MPP, can be installed if segregation is only required in sections of the bayed enclosures. This allows for the combination of installed deep components as well as segregation.

#### Required accessories:

Mounting plate brackets, MPA06

#### Limitations:

The ingress protection rating when using nVent HOFFMAN's floor standing mounting plate to separate back to back combined enclosures has not been defined.

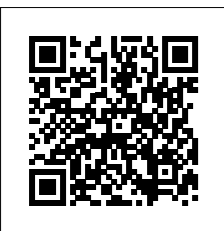

### Internal separation

## Partial mounting plate | MPP

#### Required accessories:

Click-in profile, CLPK

(If heavy equipment will be assembled in the partial mounting plate)

#### Limitations:

The ingress protection rating when using nVent HOFFMAN's floor standing partial mounting plate to separate sections of back to back bayed enclosures has not been defined.



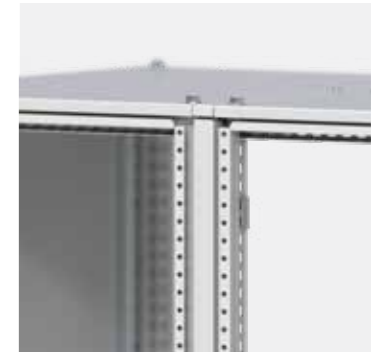
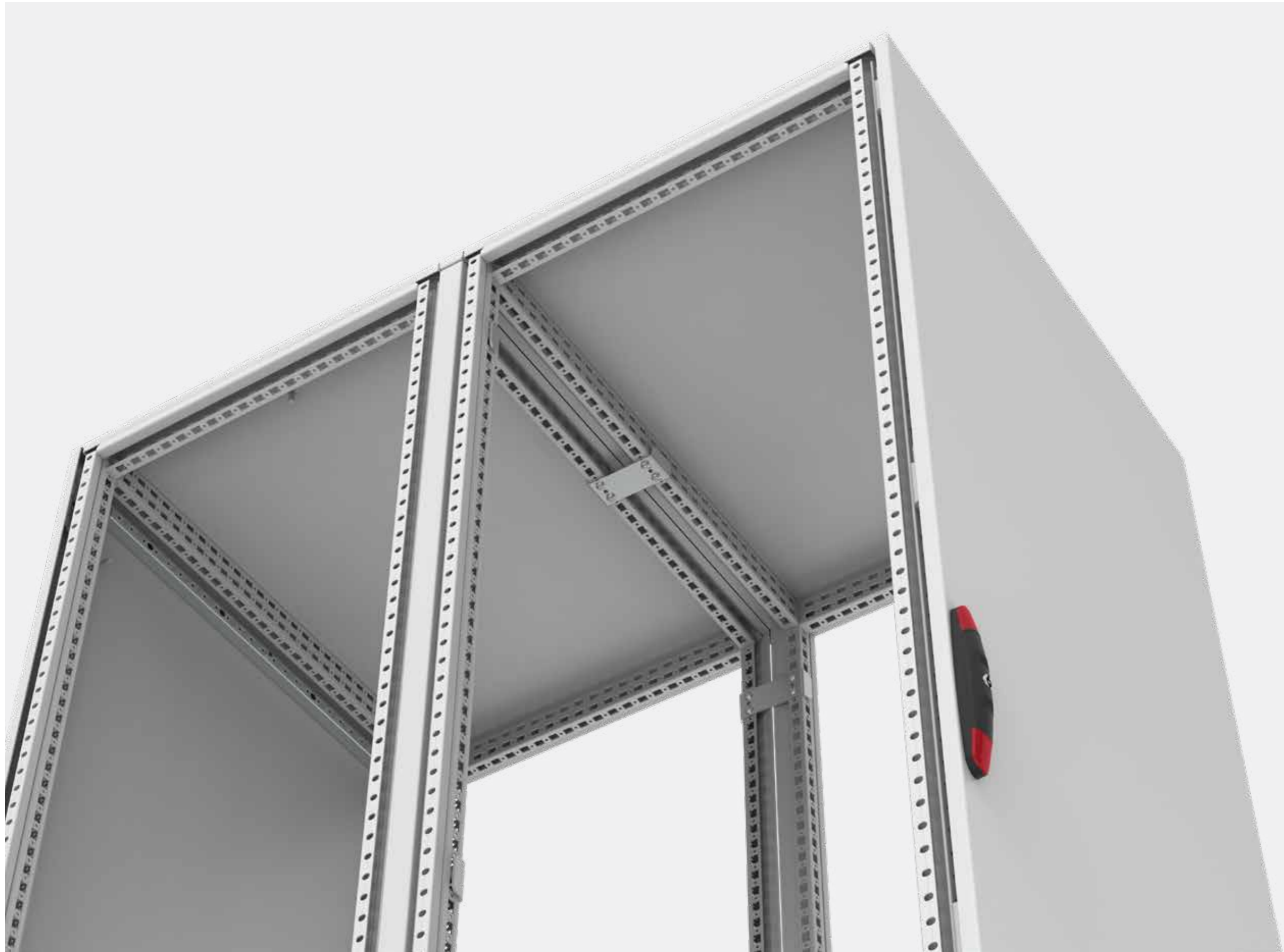

## Depth baying kit | CJDS12

### Description:

Bayed enclosures can fit into a corner using nVent HOFFMAN's corner baying kit. This kind of enclosure configuration uses minimal floor space but offers maximum installation space inside the enclosures. The enclosures can be bayed together side to front or side to side.

### Enclosure compatibility:

Floor standing combinable enclosures:  
MCS, MCD (MCSS, MCDS available on request)

### Installation:

An extra enclosure is required to be placed in the corner that must have dimensions corresponding to the depths of the adjacent enclosures. Twelve internal baying brackets are needed to bay the corner enclosure to its adjacent enclosures. Profiles and gaskets are provided to ensure the ingress protection rating is maintained.

### Limitations:

Door hinges must be facing each other on the adjacent enclosures when the corner baying kit is installed. The standard corner baying kit cannot be installed on stainless steel enclosures.



## Mounting instructions

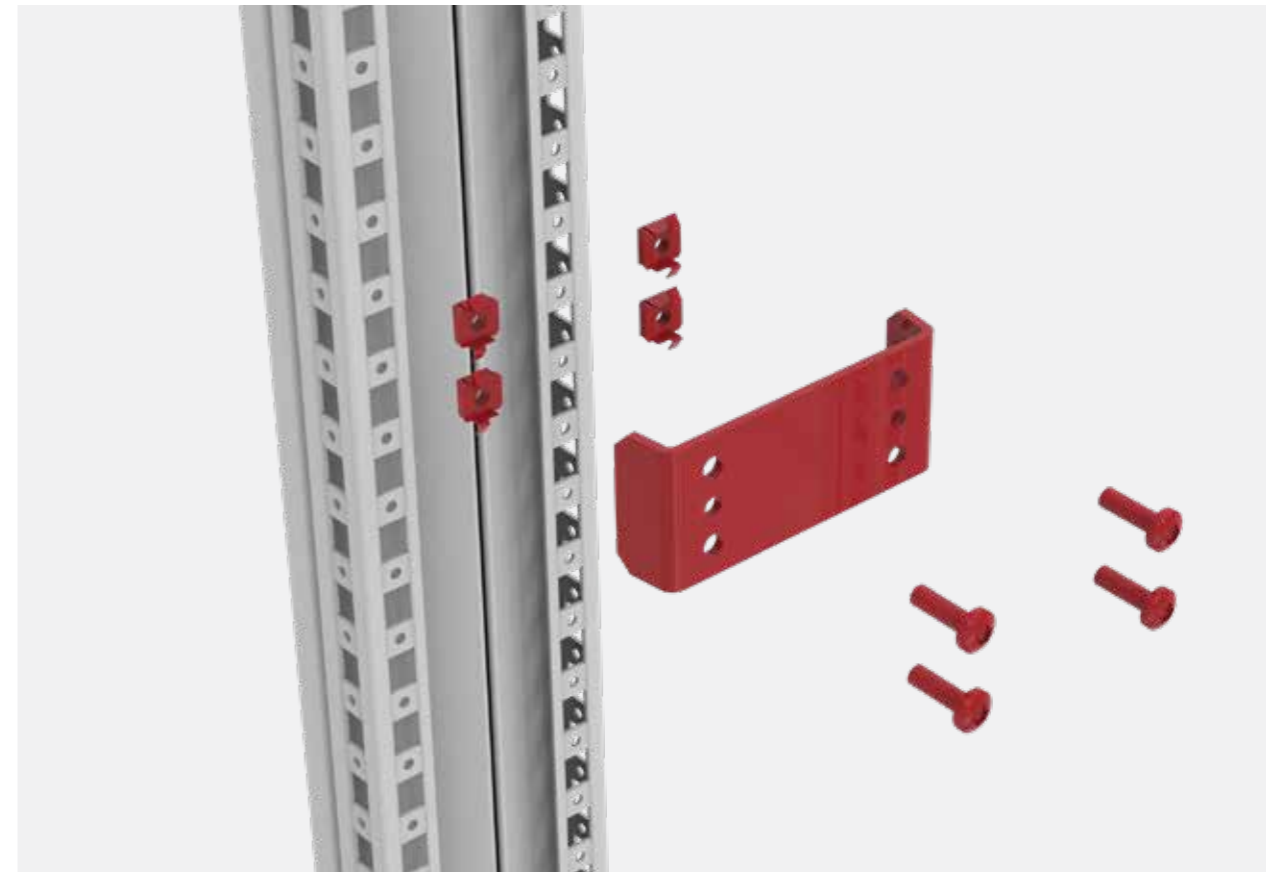
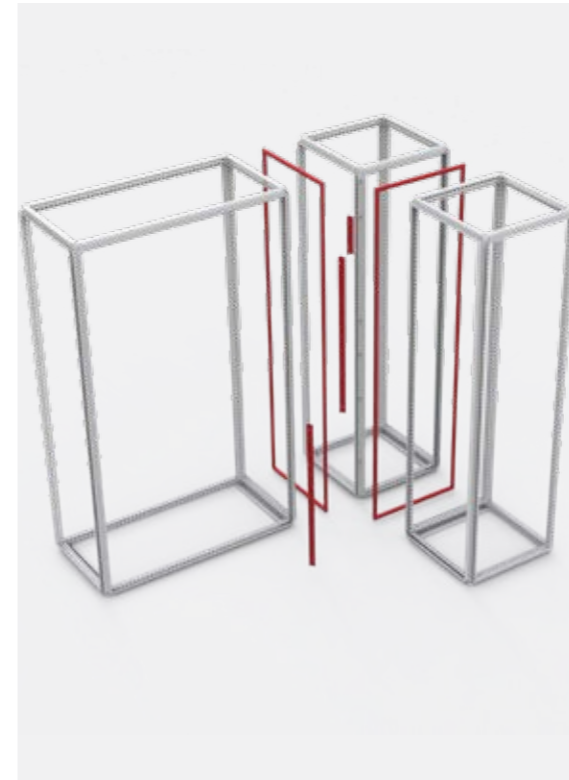

**Application**

Corner baying kits provide the perfect solution when enclosures are to be installed in environments with tight parameters and limited space. Corner baying solutions provide a lot of installation space with great accessibility, requiring less floor space than standard configurations.

Corner enclosure configurations should not be transported or lifted using the depth baying kit. To lift and transport on site, it is recommended to split the enclosure configuration up into only side to side bayed enclosures. These individual enclosure configurations can then be transported normally. The enclosures can be lifted only if internal corner baying brackets (CCM) are installed.

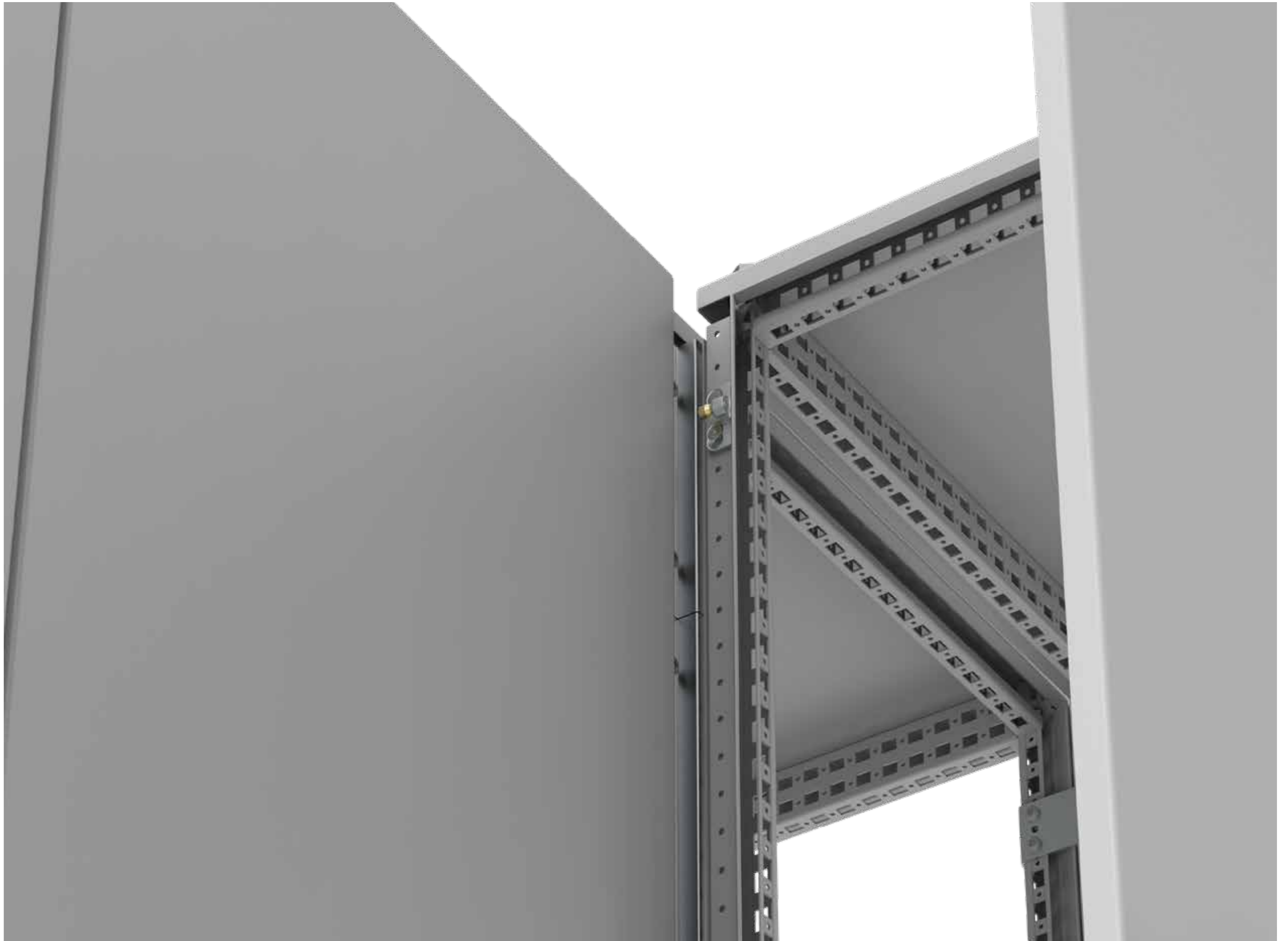

### Internal separation

## Separation plate | SPD

#### Description:

If enclosure segregation is required then a full height mounting plate, MP, with brackets can be used. Partial height mounting plates, MPP, can be installed if segregation is only required in sections of the bayed enclosures. This allows for the combination of installed deep components as well as segregation.

#### Required accessories:

Separation plate brackets, CCJ06

Separation plate gasket, SPDG01  
(To be used if IP43 is required)

Separation plate EMI gasket, SPDEG01  
(To be used if EMC shielding is required in place of SPDG01)

#### Limitations:

Cannot be used in conjunction with nVent HOFFMAN's internal baying brackets (CCI). External baying brackets (CCE) and/or a corner baying kit (CCM) should be used instead.



### Internal separation

## Side mounting plate | MPS

#### Description:

To maximize the amount of available mounting space on the enclosure's mounting plates when combinable enclosures are bayed, additional and alternative accessories can be used. In corner enclosure configurations the way to optimize the available mounting space is to use a full height mounting place installed in the rearmost position in combination with a side mounting plate.

#### Required accessories:

N / A

#### Limitations:

N / A

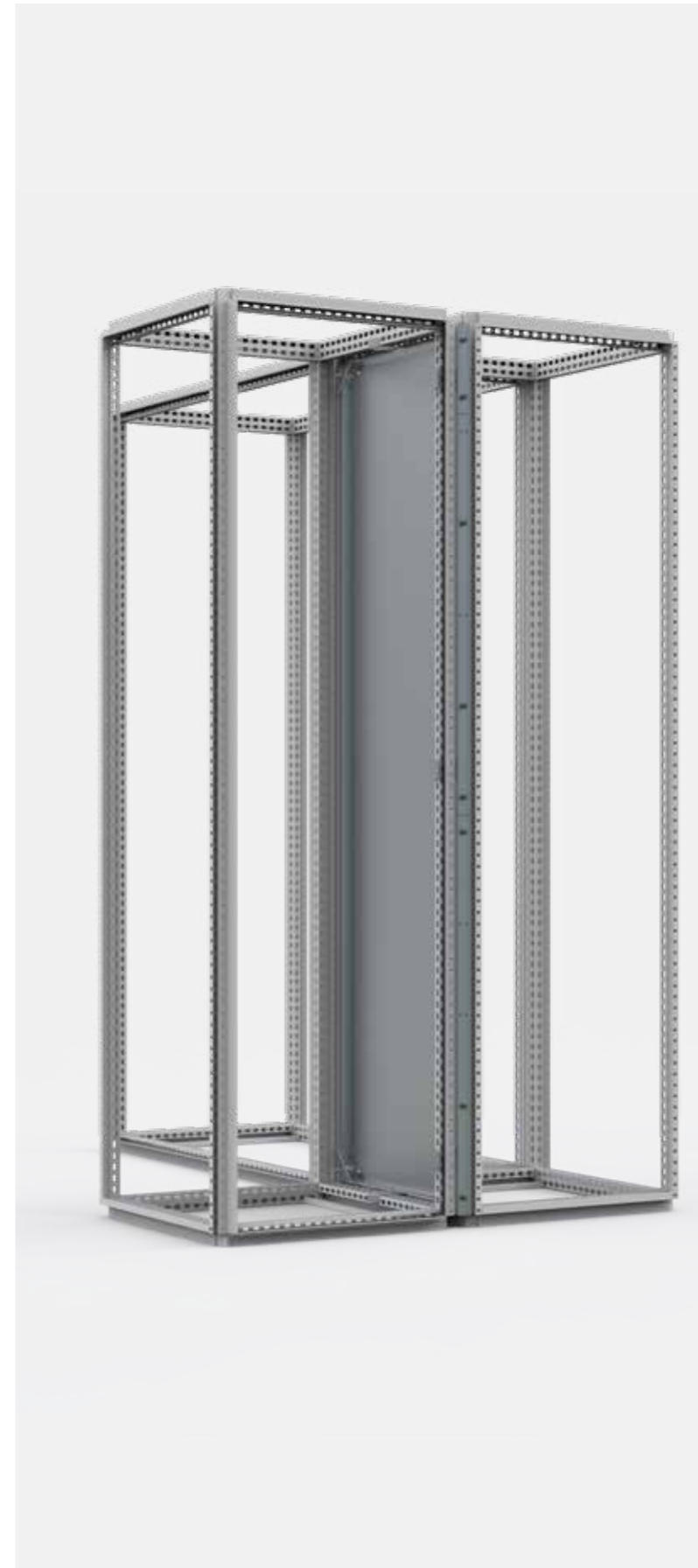

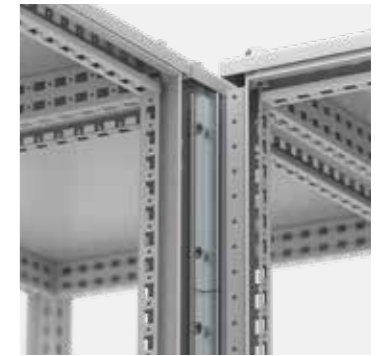



## Wall mounted combining kit | CK01

### Description:

A wall mounted combining kit is to be used for baying two or more wall mounted enclosures together, side by side. This enables customers to create many more enclosure configurations than are available within nVent HOFFMAN's standard offering. As the combining kit is delivered in a puzzle form, the same kit can be used on wall mounted enclosures as small as 300Hx150D up to 1200Hx400D. The combining kit maintains the enclosure's ingress protection rating.

### Enclosure compatibility:

Wall mounted enclosures:  
MAS, MAD, MAP, ASR, ADR

### Installation:

Machining will initially be required to cut the side out of the enclosure to the required size before installing the combining kit. Four bolts will be installed in each corner of the cutout (two additional bolts will be required for larger enclosures). The gasket should be removed from its adhesive backing and placed on the side of the enclosure to be bayed. The enclosures should be placed together and the bolts tightened to compress the gasket.

### Limitations:

Combining gasket should not be used to combine multiple stainless steel enclosures with integrated rainhoods together.

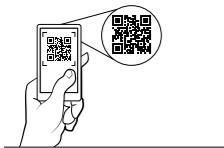

## Mounting instructions



**Application**

Wall mounted combining kits should be used to extend the internal space in width, in wall mounted enclosures for the installation of components, switchgear and other electrical devices. This also allows for components to be segregated permitting different levels of access while they maintain communication with each other. It is the perfect solution if a high ingress protection rating is required that is over and above nVent HOFFMAN's double door wall mounted enclosures.

Wall mounted side to side combined enclosures can be transported without the need for additional accessories. To lift the combined enclosures, nVent HOFFMAN's wall mounted lifting eyes need to be installed, two per enclosure (AL9301).



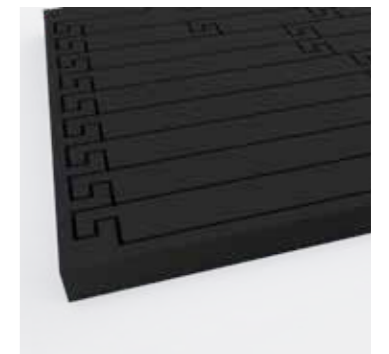

## Gland plate combining gaskets | AGC

### Description:

To be used when a vertical wall mounted enclosure combination is required. Combining gaskets are to be used to bay gland plate openings together. Gland plate combining gaskets consist of a polyethylene gasket foam that is sized for the wall mounted enclosure that requires combining. This maintains an ingress protection rating equivalent to that of the enclosure. The kit consists of two gaskets and mounting materials (i.e., screws, washers and nuts) that ensure a robust enclosure combination.

### Enclosure compatibility:

Wall mounted enclosures:  
MAS, MAD, MAP,

### Installation:

Rotate the enclosure that will be installed on the bottom 180 degrees (not applicable for MAP). Install the gasket between the two enclosures to be combined, ensuring both of the gland plates are aligned. To secure the enclosures together install the supplied bolts, washers, nuts and protective gaps.

Wall mounted enclosures come with different sized gland plates depending on the dimensions of the enclosure. Ensure the gland plate sizes of the two enclosures match before combining.

### Limitations:

Gland plate combining gasket can only be used with mild steel wall mounted enclosures.



## Mounting instructions



**Application**

Wall mounted gland plate combining kits should be used to extend the internal space, in height, of wall mounted enclosures for the installation of components, switchgear and other electrical devices.

The gland plate combining gasket is the perfect solution if components need to be separated, e.g., power and control equipment. Segregating components means that access is gained through different enclosure doors and hence different access rights can be applied while the components maintain internal communication.

Wall mounted top to bottom combined enclosures can be transported without the need for additional accessories. To lift the bayed enclosures, nVent HOFFMAN's wall mounted lifting eyes will be required (AL9301).



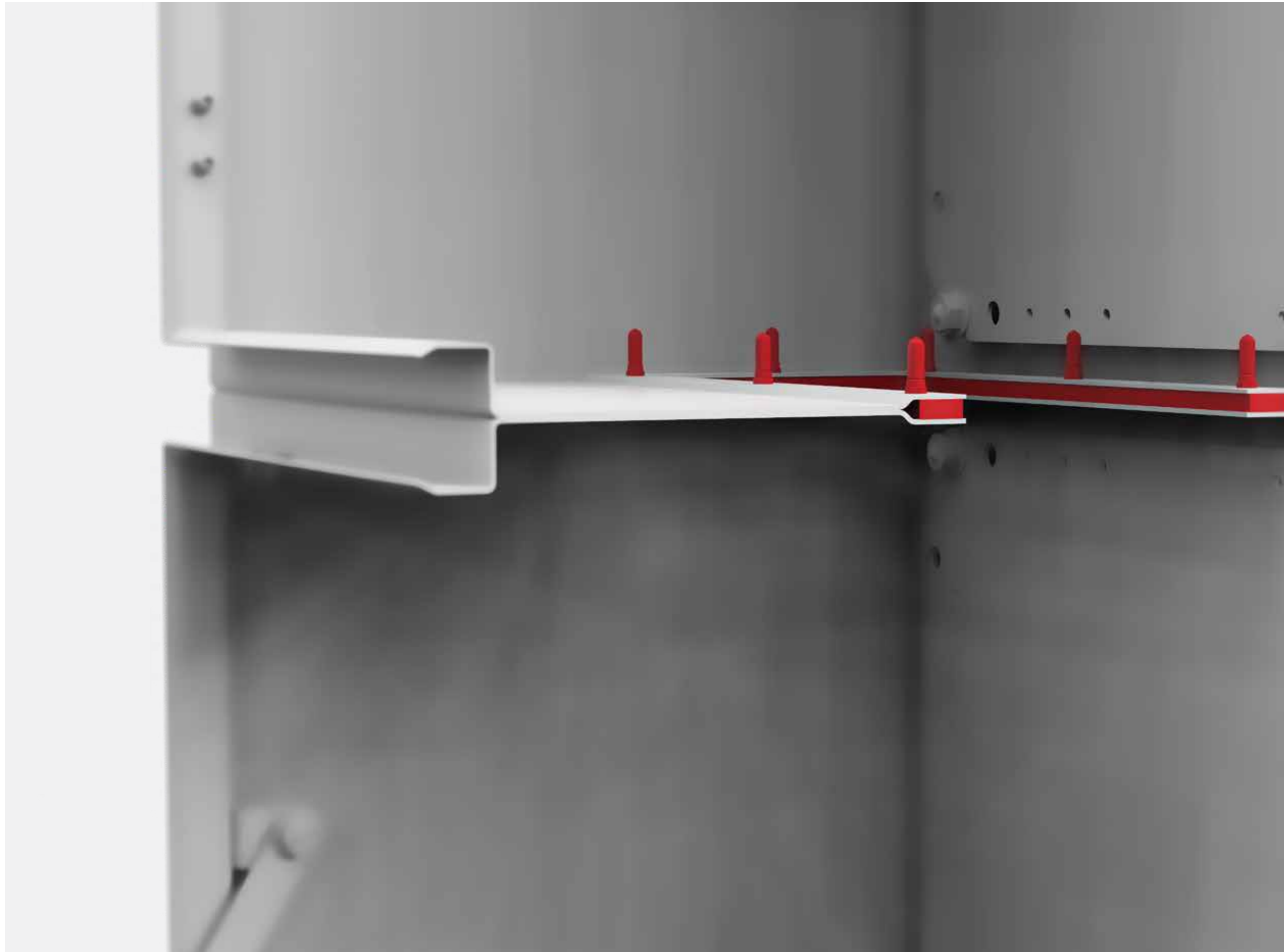



## Enclosures lifting

This section of the white paper covers all the ways to lift an nVent HOFFMAN enclosure, which accessories should be used, the effects different enclosure configurations can have, and the permissible loads allowed in nVent HOFFMAN's enclosures during these safety critical transportation operations.

Following the correct methods when transporting enclosures is critical to ensure that the enclosure's integrity is maintained and that the components installed inside are safe, secure and protected from the installation environment.

Lifting operations can be performed by a crane, forklift truck or people (depending on the load). This section covers which accessories should be used to carry out lifting operations, how the accessories should be installed and how these factors impact different enclosure configurations.

The enclosure lifting methods explained within this technical document will be suitable for craning only.



### Crane lifting angles



#### 60° angle

A crane can lift floor standing enclosures by attaching to the lifting eye bolts, creating an angle of 60 degrees to the enclosure's roof plate.



#### 90° angle

A crane can lift floor standing enclosures by attaching to the lifting eye bolts, creating an angle of 90° to the enclosure's roof plate. Cable angles of 90° to the enclosure's roof plate will support the largest loads when lifted.



#### 90° angle

A crane can lift enclosures by attaching to the lifting eye bolts, creating an angle of 90° to the enclosure's top.

## Lifting eye bolts | LE9304(SS)

### Description:

Install nVent HOFFMAN's lifting eyes on floor standing enclosures if crane transportation is required. Individually transported enclosures will require four lifting eyes to be fitted, one in each corner. Lifting eyes come with M12 threads and comply with DIN 580 lifting requirements.

### Enclosure compatibility:

Floor standing combinable enclosures:  
MCS, MCD, MCSS, MCDS, MKS, MKD, EKS, EKD, EKSS, EKDS

For stainless steel enclosures use lifting eyes with the suffix 'SS'

### Installation:

To install nVent HOFFMAN's lifting eyes remove the caps or bolts from each corner of the enclosure's roof plate and thread the lifting eyes into the threaded frame or blind rivet nuts that are already installed.

### Limitations:

N / A.

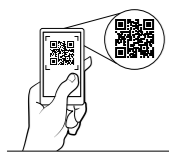

## Mounting instructions



**Lifting capacity**

Individual floor standing enclosures can be transported by crane safely using the enclosure's lifting eyes. The load installed inside the enclosure is systematically distributed allowing for a smooth transit.

Cable lifting angle (°)	Permissible load (N)
45	4800
60	6400
90	13600



## Lifting kit | MCUK04

### Description:

nVent HOFFMAN's lifting kit is to be installed and used on enclosures that are fitted with top cabling frames.

The lifting kit fits directly into the enclosure's frame, therefore during lifting operations no stress is applied to the cabling frame, it is directed straight into the enclosure

### Enclosure compatibility:

Floor standing combinable enclosures:  
MCS, MCD,

### Installation:

To install nVent HOFFMAN's lifting kit ensure there are no bolts or caps installed on the top of the cable frame. Install the lifting kit spindles through each hole of the cable frame and thread into the enclosure's blind rivet nuts.

### Limitations:

Once installed the lifting kit can only be lifted at an angle of 90° from the enclosure's roof plate. The lifting kit is only suitable for cabling frames that are 200mm high.



## Mounting instructions

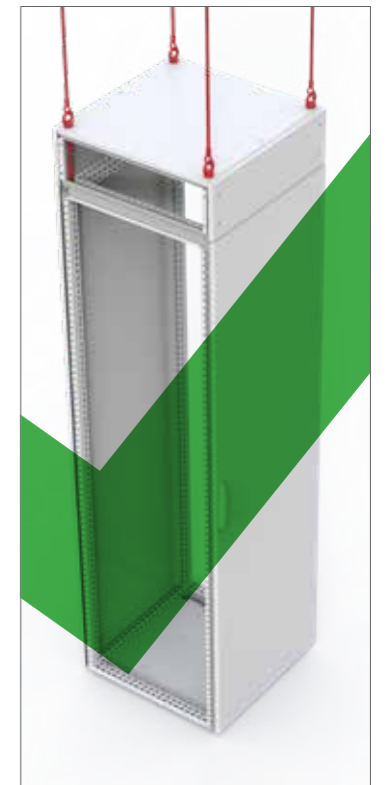

**Lifting capacity**

Individual floor standing enclosures with a top cabling frame installed can be transported by crane safely using the enclosure's lifting kit. The load installed inside the enclosure is systematically distributed allowing for smooth transit.

Cable lifting angle (°)	Permissible load (N)
90	13600



## Lifting eye bolts | LE9304 (SS)

### Description:

Install nVent HOFFMAN's lifting eyes on floor standing enclosures if crane transportation is required. Two side to side bayed enclosures will require four lifting eyes to be fitted, one in each corner of the combined unit.

Lifting eyes come with M12 threads and comply with DIN 580 lifting requirements.

### Enclosure compatibility:

Floor standing combinable enclosures:  
MCS, MCD, MCSS, MCDS,

For stainless steel enclosures use lifting eyes with the suffix 'SS'

### Installation:

To install nVent HOFFMAN's lifting eyes remove the caps or bolts from each corner of the enclosure's roof plate and thread the lifting eyes into the threaded frame or blind rivet nuts that are already installed. The corner baying kit, CCM04, will be required for side to side bayed enclosures during transportation and lifting operations.

### Limitations:

N / A.

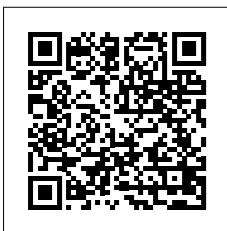
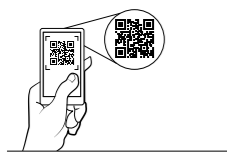

## Mounting instructions



**Lifting capacity**

If required, nVent HOFFMAN's lifting eyes can also be installed to lift side to side bayed enclosures for transportation purposes and to ensure that the enclosures can be installed regardless of the location. Lifting eyes can be lifted at an angle of either 60 or 90 degrees from the horizontal.

Cable lifting angle (°)	Permissible load (N)
60	3200 in each enclosure
90	5100 in each enclosure



## Lifting device | LC

### Description:

Install nVent HOFFMAN's lifting device on floor standing enclosures for optimal weight distribution when lifting bayed enclosures. The lifting device only needs to be installed on the sides where the enclosures are bayed.

### Enclosure compatibility:

Floor standing combinable enclosures:  
MCS, MCD  
(MCSS, MCDS available on request)

### Installation:

To install nVent HOFFMAN's lifting device ensure there are no bolts or caps already fitted on the enclosure's roof plate. Bay the floor standing enclosures together using nVent HOFFMAN's baying brackets. Install a lifting device on either side of the two or more enclosures that will be bayed and secure using the M12 bolts supplied. The corner baying kit, CCM04, will be required for side to side bayed enclosures during transportation and lifting operations.

### Limitations:

The lifting device is made from zinc plated steel and if mounted on stainless steel enclosures it must be removed and replaced with bolts or caps afterwards.

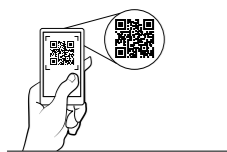

## Mounting instructions



**Lifting capacity**

Two floor standing enclosures bayed side by side can be transported by crane safely using the applicable lifting accessories. The load installed inside the enclosure is systematically distributed allowing for smooth transit. The lifting accessory required for side to side bayed enclosures is nVent HOFFMAN's lifting device.

Cable lifting angle (°)	Permissible load (N)
60	7000



**Lifting capacity**

It is also possible to lift three enclosures bayed side to side using nVent HOFFMAN's lifting device. The lifting device ensures that the weight installed inside the enclosures is equally distributed resulting in smooth transit. The permissible load for each enclosure will depend on the enclosure's position within the configuration.

Enclosure position	Permissible load (N)
	7000
	13000



Back to back bayed enclosures should be separated before being transported and/or lifted. The required accessories and permissible loads are covered under the standalone enclosure section.



Corner bayed enclosures should be separated before being transported and/or lifted. The required accessories and permissible loads are covered under the standalone and side to side installation sections.



## Lifting eyes | AL9301

### Description:

Install nVent HOFFMAN's lifting eyes on wall mounted enclosures if crane transportation is required. Wall mounted enclosures will only require two lifting eyes and should be installed as per nVent HOFFMAN's mounting instructions.

### Enclosure compatibility:

Wall mounted enclosures:  
MAS, MAD, ASR, ADR

### Installation:

To install nVent HOFFMAN's lifting eyes, machine two holes in the rear two corners as per the mounting instructions. Insert the lifting eyes through the machined holes and secure using the reinforcement brackets, washers and nuts provided. Reinforcement brackets are supplied to ensure that the enclosure is supported adequately when lifted.

### Limitations:

The lifting eyes are made from zinc plated steel and if mounted on stainless steel enclosures they must be removed afterwards and replaced with bolts or caps.



## Mounting instructions



**Lifting capacity**

Individual wall mounted enclosures can be transported by crane safely using the enclosure's lifting eyes. The load that is installed inside the enclosure is systematically distributed allowing for smooth transit.

Cable lifting angle (°)	Permissible load (N)
45	2400
60	3200
90	4000



Our powerful portfolio of brands:

**CADDY**

**ERICO**

**HOFFMAN**

**RAYCHEM**

**SCHROFF**

**TRACER**



[eldon.com](http://eldon.com)  
[HOFFMAN.nVent.com](http://HOFFMAN.nVent.com)

©2020 nVent. All nVent marks and logos are owned or licensed by nVent Services GmbH or its affiliates. All other trademarks are the property of their respective owners. nVent reserves the right to change specifications without notice. Baying and lifting, 1.0.

Distributed by Gross Automation | +1 (262) 252-1600 | [sales@grossautomation.com](mailto:sales@grossautomation.com)