



**Beyond**

™

**Susol**  
**OEM Switchboard**  
LSB Series



**LS** *ELECTRIC*

# Reliable & Flexible UL 891 Power Distribution

Beyond X™ Susol UL 891 Switchboards are designed, built, and tested in accordance with UL standards, delivering reliable power distribution and protection.

Configurable as either a service entrance or a distribution switchboard, they support a wide range of applications that demand stability and dependability.

With a metal-enclosed, free-standing structure, Beyond X™ Susol switchboards provide a practical and economical solution for modern power systems.

# BeyondX™ Susol OEM Switchboard LSB Series



## Contents

---

Overview	04
Product description	06
Pull/Service equipment section	10
Individually mounted section	12
Combination mounted section	17
Group mounted section	22
Interior	25
Bus Strap Kit	26
Section Lineup	28
LSPE-X user manual	30

---

# Overview

## Overview

The Beyond X™ LSB series OEM switchboard is the minimalist version of the Susol UL low voltage switchboard line. The design is identical, but ships as an OEM-friendly package including only the panel enclosures and busbars so our OEM partners can integrate circuit breakers, controls and instrumentation, and other components. LSB OEM switchboards is available as one of Four options: Service entrance section, individually mounted section (main and feeder), combination sections and group mounted sections. (feeder). Customers can easily configure and order these assemblies with our catalog's configuration tool (LSPE -X, [www.lspe-x.lsectric.com](http://www.lspe-x.lsectric.com)) with configured outline diagrams and quick quote.



## Section type

**1** Pull/Service equipment section

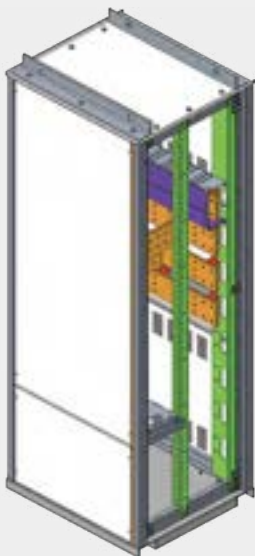

**2** Individually mounted section



**3** Combination section



**4** Group mounted section



### Note.

The devices (power circuit breaker or molded case circuit breaker) are supplied separately from the structure kit or assembled in the structure kit. Breakers shown above are not included in switchboard assemblies from this catalog. ACB and MCCB products must be ordered separately.

## Typical arrangement

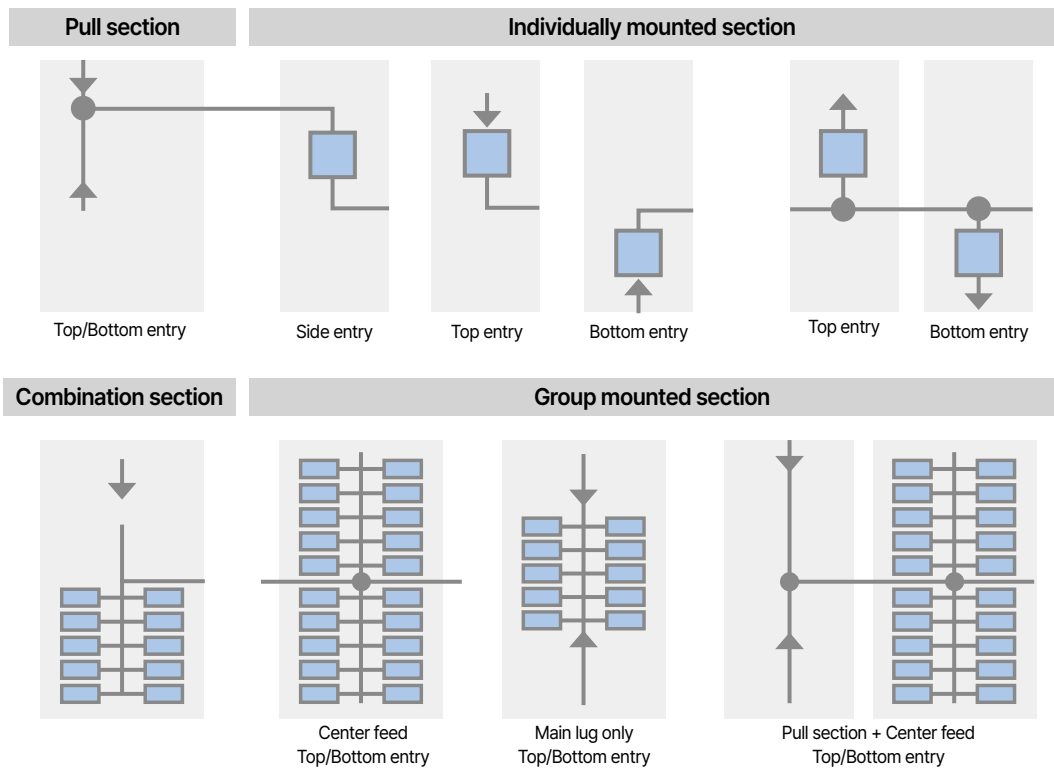

## Supply scope

### ■ Front

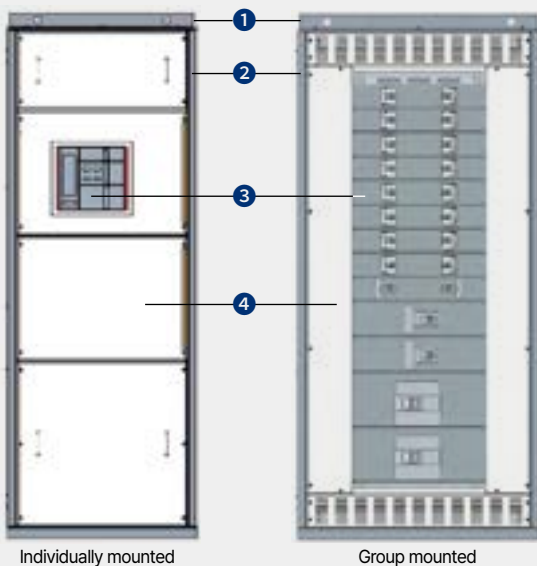

### ■ Side

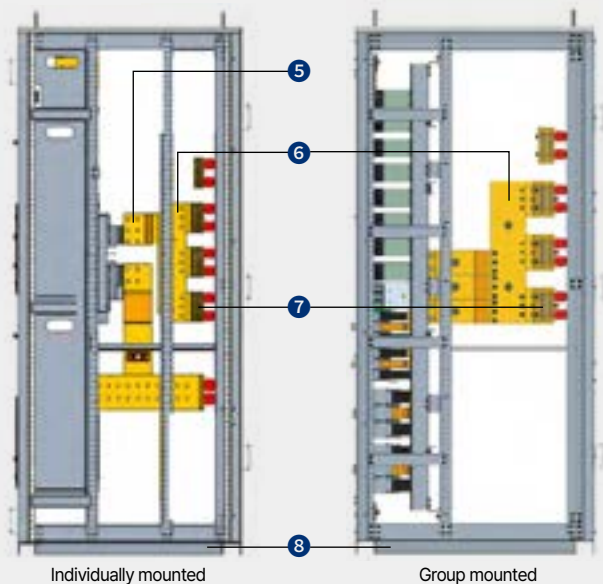

No.	Part description	Supply scope
1	Top cover ass'y	✓
2	Frame ass'y	✓
3	Circuit breaker (Fixed or draw-out)	-
4	Cover ass'y	✓

No.	Part description	Supply scope
5	Line-load busbar	✓
6	Section busbar	✓
7	Main busbar	✓
8	Channel ass'y	✓

# Product description

## General information

### Ratings

- Voltage up to 800VAC
- 50 / 60 Hz
- Up to 4000A bus rating aluminum and up to 6000A bus rating Copper
- Breaking capacity up to 100kA
- Circuit breaker available up to 6000A

### Enclosure dimensions

- NEMA Type 1
- Front accessible
- Top, bottom and side entry options
- Height: 90"(2286 mm) with base channels, top entry option : 115" (top hat will be packaging seperated)
- Widths: 30"(762mm), 32"<sup>1)</sup> (812.8mm), 36"(914.4mm), 42"(1066.8mm), 44"(1117.6mm)
- Depths: 26"(660.4mm), 32"(812.8mm), 36"(914.4mm), 40"(1016mm), 45"(1143mm)

**Note 1)** 32" width enclosure is applied to the E-type aluminum ~2500AF individually mounted section

### Standards

- UL 891

### Applications

#### Building

- Commercial and residential
- Data center
- Hospital
- Large office building
- Large warehouse
- University

#### Industry

- Chemical
- Mining and material
- Iron and steel
- Food and beverage
- Pharmaceutical
- Automobile
- Battery

#### Utility / Public

- Wastewater
- Airport



## Structure features

### Frame

Susol UL LV switchboard frames are constructed with solid, formed steel channels and secured together by the base channel. This minimizes structural warping and promotes support of internal components. Lifting angles are standard atop all sections for ease of shipping and installation.

### Door and cover

Doors and covers are made from 10 gauge steel with formed edges and bolted to the frame for superior safety as well as ease of access for maintenance.

### Enclosure and finish

Enclosures are NEMA 1 indoor type with an ANSI 61 gray finish.

### Cable compartment

Cable compartments are designed with consideration to cable bending space, bus duct risers and transformer connections for variable use cases. Also included is an isolated control and communication wiring section for protection and clean installation.

- Designs for cable, bus duct riser, cable bus, cable duct, and transformer connections
- Secure front access with completely isolated control and communication wiring sections
- Structure enables future installation and expansion of additional equipment

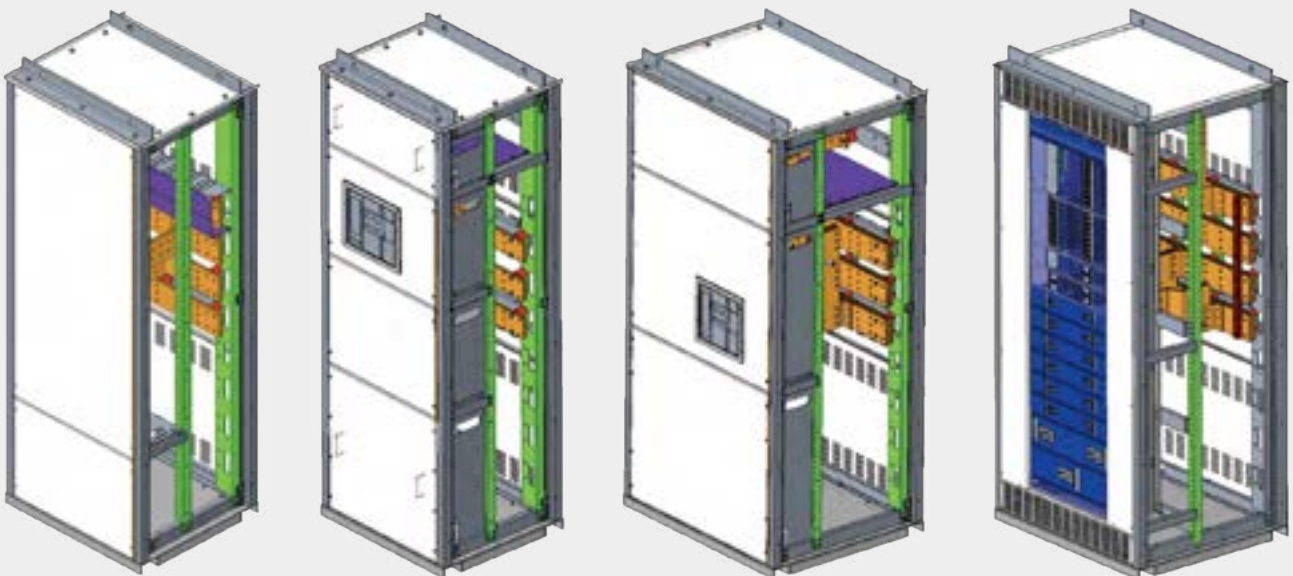

# Product description

## Bus system

The Susol UL LV switchboard bus system is installed at the rear of the switchboard and constructed from high-density, tin-plated copper rated at 1000 A/sq.in. or aluminum rated at 750 A/sq.in. The design is verified by a temperature rise test for cUL certification at ratings over 3000A. Each configuration is available with ratings from 2000–4000A applied aluminum bus and 2000-6000A applied copper busbar. The Busbar bracing can be design up to 100 kAIC. A neutral bus is included as standard in each 4-wire section and is rated at 100% of the main bus.

**Note.**

Tin-plated copper is the standard specification. If silver-plated copper is needed, please contact the LS ELECTRIC sales or engineering team.

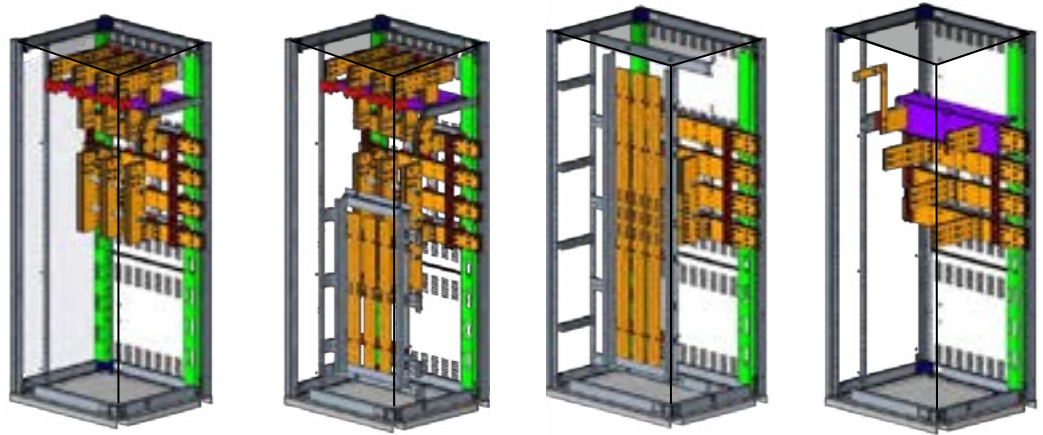

## Ratings

### LSB OEM switchboard : individually & combination mounted section

Access		Front				
Bus material		Copper		Aluminum		
Designation		LSB-i (ACB 1-stack)	LSB-C (ACB 1-stack + interior)	LSB-i (ACB 1-stack)	LSB-C (ACB 1-stack + interior)	
Main device	ACB	E-2000 / 2500 / 3200 G-4000 / 5000 / 6000	E-2000 / 2500 / 3200 G-4000 / 5000 / 6000	E-2000 / 2500 / 3200 / G-4000	E-2000 / 2500 / 3200 / G-4000	
	MCCB	-	100-1200 A	-	100-1200 A	
Feeder device	MCCB	-	100-1200 A	-	100-1200 A	
	ACB	E-2000 / 2500 / 3200 G-4000 / 5000 / 6000	E-2000 / 2500 / 3200 G-4000 / 5000 / 6000	E-2000 / 2500 / 3200 / G-4000	E-2000 / 2500 / 3200 / G-4000	
S.C withstand current		Up to 100 kA @ 480 / 600 / 800 V		Up to 100 kA @ 480 / 600 / 800 V		
Main bus ampacity		Up to 6000 A		Up to 4000 A		
Interior ampacity		-	2000 / 4000 / 6000 A	-	2000 / 4000 A	
Bus or cable entry		Top / Bottom / Side	Top / Stand-alone	Top / Bottom / Side	Top / Stand-alone	
Rated operating voltage		Up to 600 V for G frame / Up to 800 V for E frame		Up to 600 V for G frame / Up to 800 V for E frame		
Enclosure size [in.]	Width	E-2000 AF / E-2500 AF	30	36	32	36
		E-3200 AF	36	36	36	36
		G-4000 AF	44	44	44	44
		G-5000 AF / G-6000 AF	44	44	-	-
	Depth (Min.)	E-2000 AF / E-2500 AF	26 (F) / 32 (D)	32 (F/D)	26 (F) / 32 (D)	32 (F/D)
		E-3200 AF	32 (F) / 36 (D)	32 (F) / 36 (D)	32 (F) / 36 (D)	32 (F) / 36 (D)
		G-4000 AF	36 (F) / 40 (D)	36 (F) / 40 (D)	36 (F) / 40 (D)	36 (F) / 40 (D)
		G-5000 AF G-6000 AF	45 (D)	45 (D)	-	-
	Height		90		90	
	Enclosure type		NEMA 1		NEMA 1	
Internal separation (optional)		IP 2X		IP 2X		
Seismic		IEEE 693 High (2.5g) / ICC ES AC 156 (2.5g)		IEEE 693 High (2.5g) / ICC ES AC 156 (2.5g)		

### LSB OEM switchboard : Pull/Service entrance & group mounted section

Access		Front				
Bus material		Copper		Aluminum		
Designation		LSB-G (MCCBs)	LSB-P/S (Cable lug)	LSB-G (MCCBs)	LSB-P/S (Cable lug)	
Feeder device	MCCB	100-1200 A	No CBs needed	100-1200 A	No CBs needed	
S.C withstand current		Up to 100 kA @ 480 / 600 / 800 V		Up to 100 kA @ 480 / 600 / 800 V		
Main bus ampacity		Up to 6000 A		Up to 4000 A		
Interior ampacity		2000 / 4000 / 6000 A	-	2000 / 4000 A	-	
Interior incoming type		Center feed / MLO (Stand-alone)	-	Center Feed / MLO (Stand-alone)	-	
Rated operating voltage		480 / 600 / 800 V		480 / 600 / 800 V		
Enclosure size [in.]	Width	Through bus 2000 / 2500	30	36	30	
		Through bus 3200 / 4000	42	36	36	
		Through bus 5000 / 6000		42	-	
	Depth (Min.)	Through bus 2000 / 2500	26 / 32	26 / 32	26 / 32	26 / 32
		Through bus 3200 / 4000	32 / 36 / 40	32 / 36 / 40	32 / 36 / 40	32 / 36 / 40
		Through bus 5000 / 6000	40 / 45	40 / 45	-	-
Height		90		90		
Enclosure type		NEMA 1		NEMA 1		
Internal separation (optional)		IP 2X		IP 2X		
Seismic		IEEE 693 High (2.5g) / ICC ES AC 156 (2.5g)		IEEE 693 High (2.5g) / ICC ES AC 156 (2.5g)		

# Pull/Service equipment section | LSB-P/S

## Description

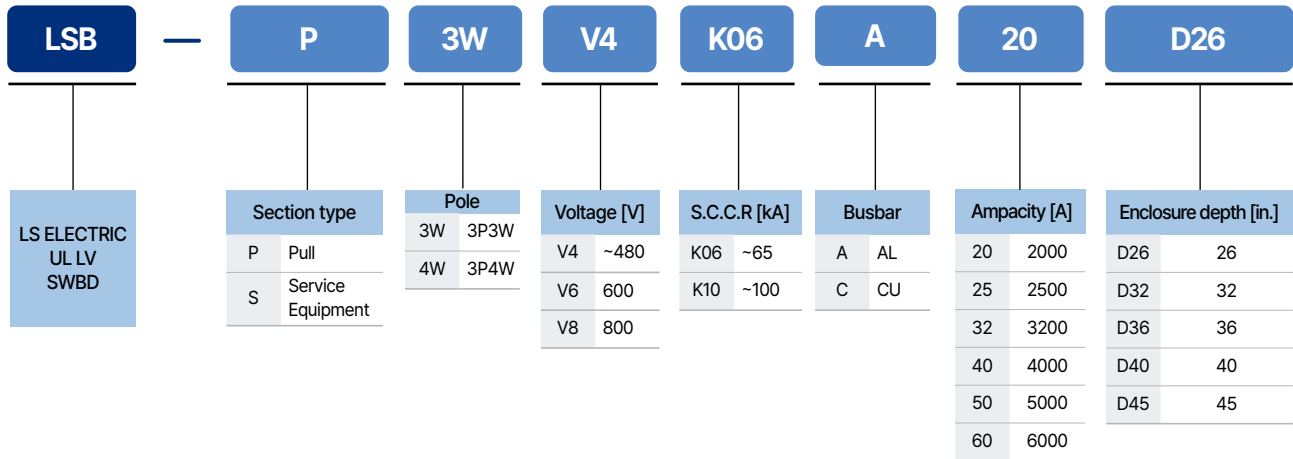

Table 1. Available depth of each section for device type and ampacity rating

ACB frame type	ACB ampacity	Mount type	Available Depth [in.] Through bus ampacity				
			2000A	2500A	3200A	4000A	5000&6000A
E	2000A	Fixed	26/32	26/32	32/36	36/40	45
		Draw-out	32	32	32/36	36/40	45
	2500A	Fixed	-	26/32	32/36	36/40	45
		Draw-out	-	32	32/36	36/40	45
	3200A	Fixed	-	-	32/36	36/40	45
		Draw-out	-	-	36	36/40	45
G	4000A	Fixed	-	-	-	36/40	45
		Draw-out	-	-	-	40	45
	5000&6000A	Fixed	-	-	-	-	-
		Draw-out	-	-	-	-	45
LSB-G series (Center feed incoming type, minimum depth)			26	26	32	36	45

When joining other LSB series sections side by side, consider the minimum depth size of the sections being joined. To align the enclosures (front and rear) within the group, select the depth of the section with the largest depth size in the group.

- Note. 1)** The pull section and service equipment section limit the width of the enclosure based on the through busbar ampacity. The LSB-P and LSB-S provide a 30" wide enclosure for through busbar ampacities under 2500A, and a 36" wide enclosure for ampacities over 3200A. For different size enclosures, please contact LS ELECTRIC sales or engineering team.
- 2)** 5000A/6000A ACB is available only in draw-out type

## Layout and dimensions

### Copper / Aluminum bus system

#### Features

- Main busbar rating: Up to 6000 A (Copper), Up to 4000 A (Aluminum)
- Enclosure size (Min. W x HxD): 32"x90"x26" (812.8 x 2281.2 x 660.4mm)
- Bus rating: Main bus and vertical bus up to 100kA
- Available in top or bottom entry

#### Layout

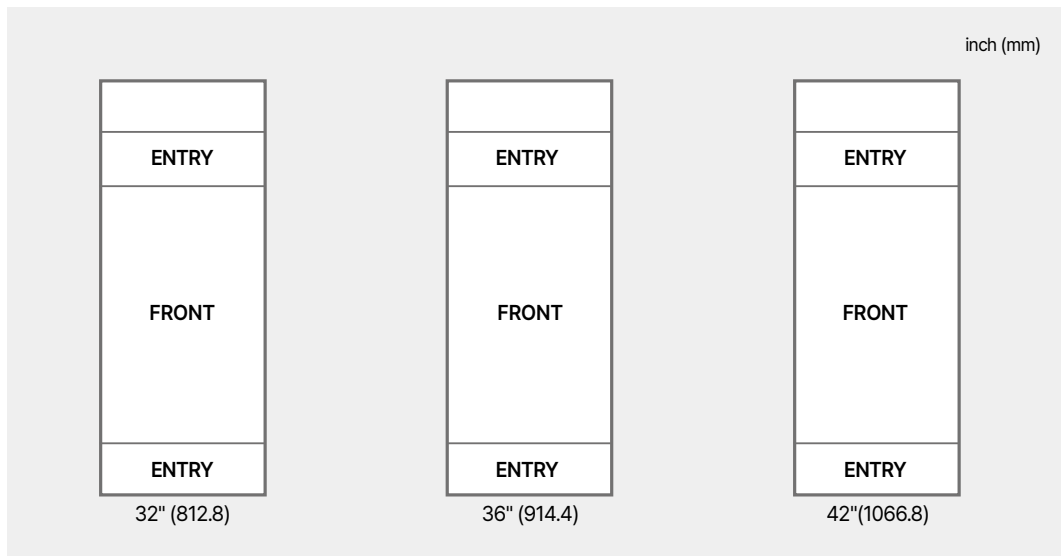

#### Available ampacity

Comp.	Available layout
Front	Blank, Instrument, LV compartment
Entry	Cable or busduct entry (Top and bottom available)

#### Dimensions

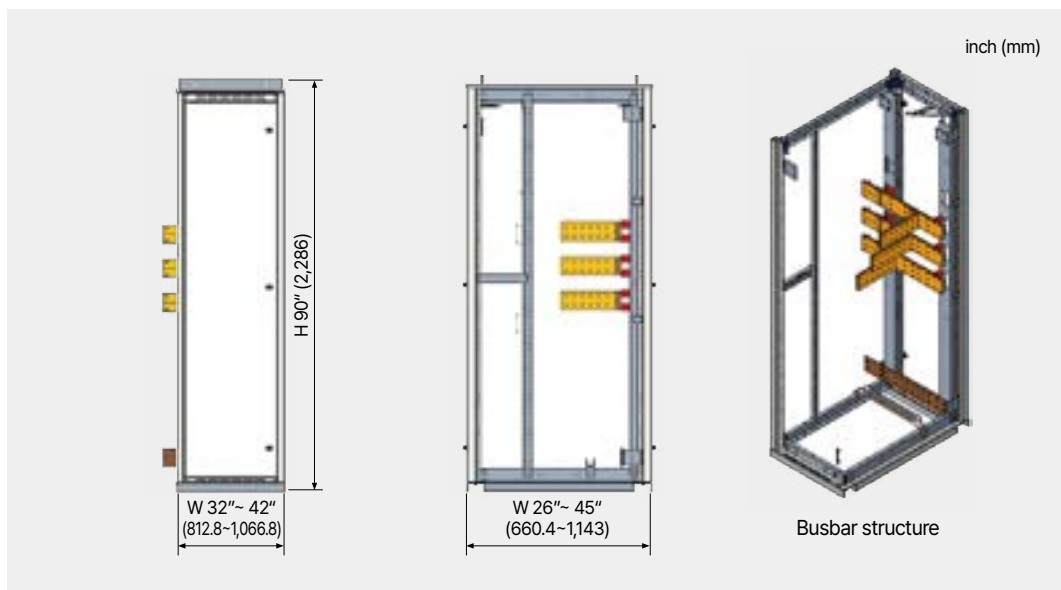

# Individually mounted section | LSB-i

## Description

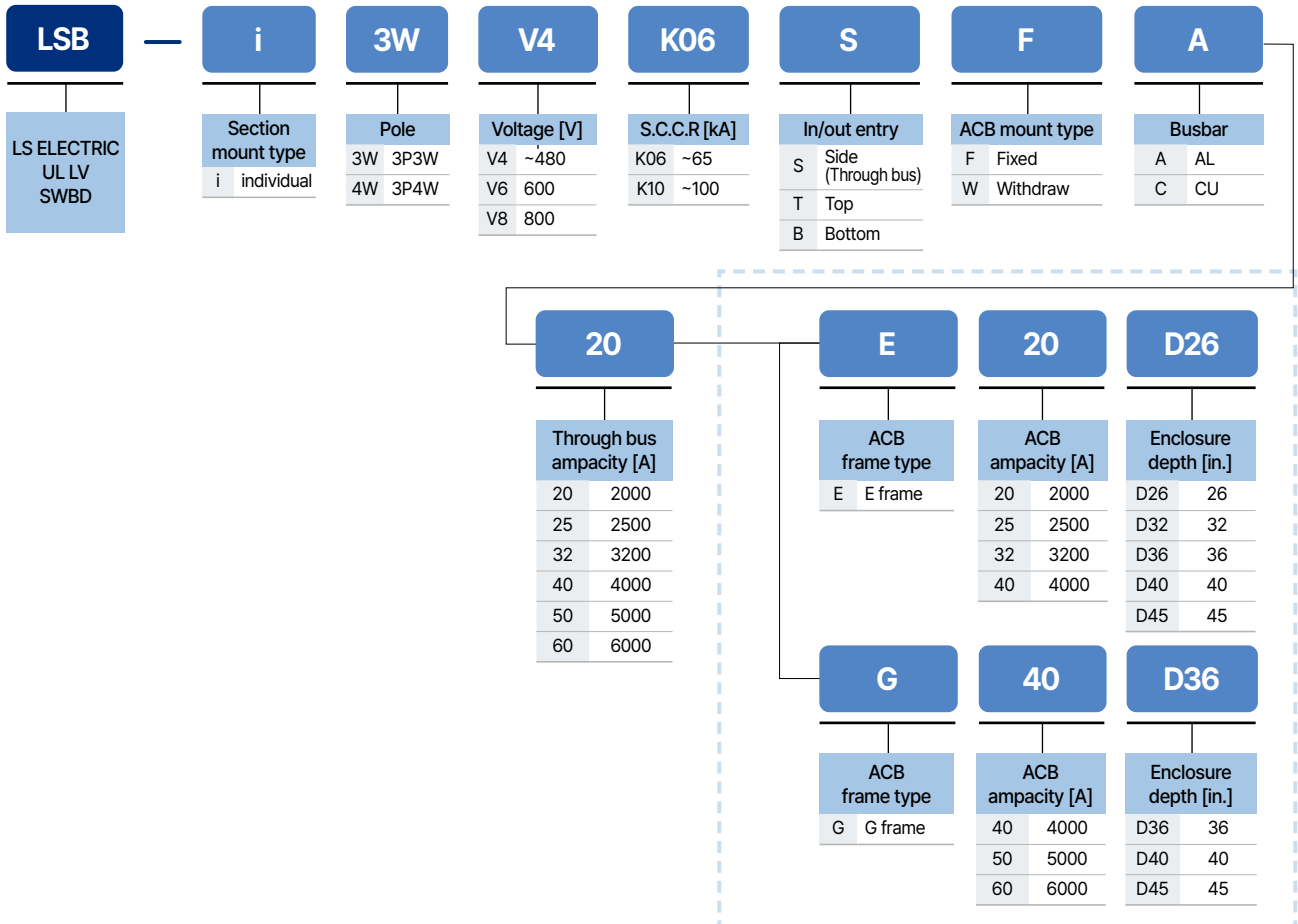

Table 1. Available depth of each section for device type and ampacity rating

ACB frame type	ACB ampacity	Mount type	Available depth [in.] Through bus ampacity					
			2000A	2500A	3200A	4000A	5000&6000A	
E	2000A	Fixed	26/32	26/32	32/36	36/40	45	
		Draw-out	32	32	32/36	36/40	45	
	2500A	Fixed	-	26/32	32/36	36/40	45	
		Draw-out	-	32	32/36	36/40	45	
	3200A	Fixed	-	-	32/36	36/40	45	
		Draw-out	-	-	36	36/40	45	
G	4000A	Fixed	-	-	-	36/40	45	
		Draw-out	-	-	-	40	45	
	5000&6000A	Fixed	-	-	-	-	-	
		Draw-out	-	-	-	-	45	
	LSB-G series (Center feed incoming type, minimum depth)			26	26	32	36	45

The minimum enclosure depth is determined by the ACB/Main frame size and mounting type.

When browsing configuration options, consider that each section must have the same total depth for proper installation and connection.

Note. 1) Pull boxes/sections may need to be added depending on selection conditions (refer to the layout and dimensions).

2) 5000A/6000A ACB is available only in draw-out type

## Layout and dimensions

### Copper bus system (E-frame 2000, 2500, 3200A)

#### Features

- Main / feeder tie circuit breaker: up to 3200A
- Enclosure size( Min. W×H×D): 30"×90"×26" (762×2281.2×660.4mm)
- Bus rating: Main bus and vertical bus up to 100kA
- Available in top or bottom feed
- One stack layout only: The LSB Series can be configured as 2 or 4-stack. Please contact the LS ELECTRIC Sales and Engineering team for more information, referring to the LSB Switchboard Series catalog.

#### Layout

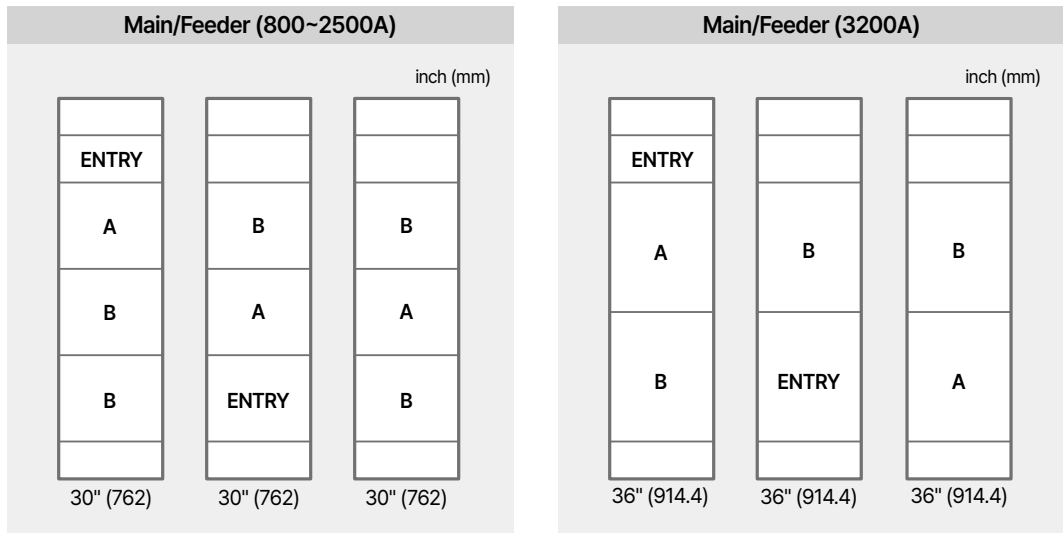

#### Available ampacity

Comp.	Available ampacity W30" section	Available ampacity W36" section
A	~2000, 2500A	3200A
B	Blank, Instrument, LV compartment	
Entry	Cable or busduct entry (Top and bottom available)	

#### Dimensions

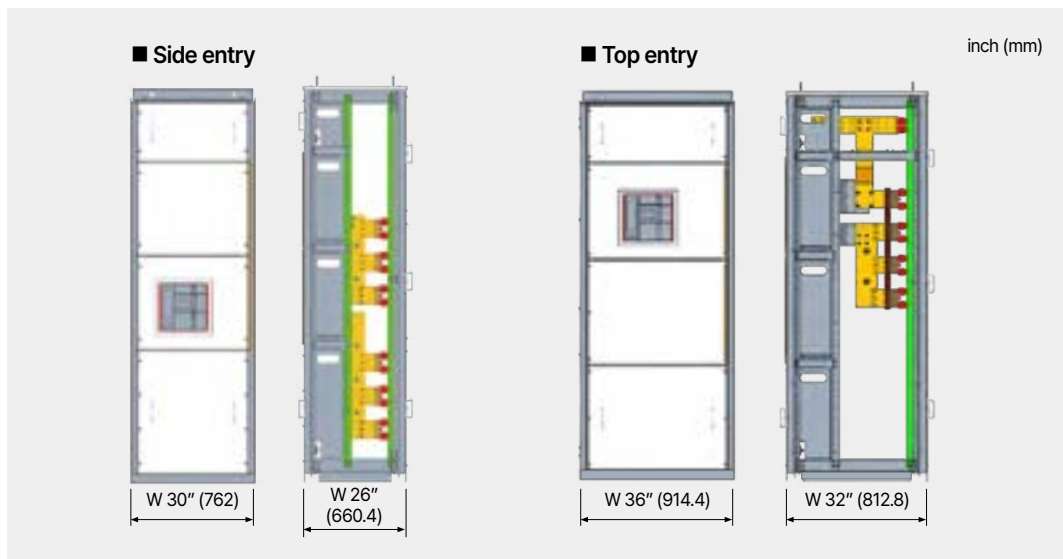

# Individually mounted section | LSB-i

## Layout and dimensions

### Copper bus system (G-frame 4000A, 5000&6000A)

#### Features

- Main / feeder tie circuit breaker: up to 6000A
- Enclosure size (Min. W×H×D): 44"×90"×36" (1117.6 × 2281.2 × 914.4mm)
- Bus rating: Main bus and vertical bus up to 100kA
- Available in top or bottom feed
- One stack layout only: The LSB Series can be configured as 2 or 4-stack. Please contact the LS ELECTRIC Sales and Engineering team for more information, referring to the LSB Switchboard Series catalog.

#### Layout

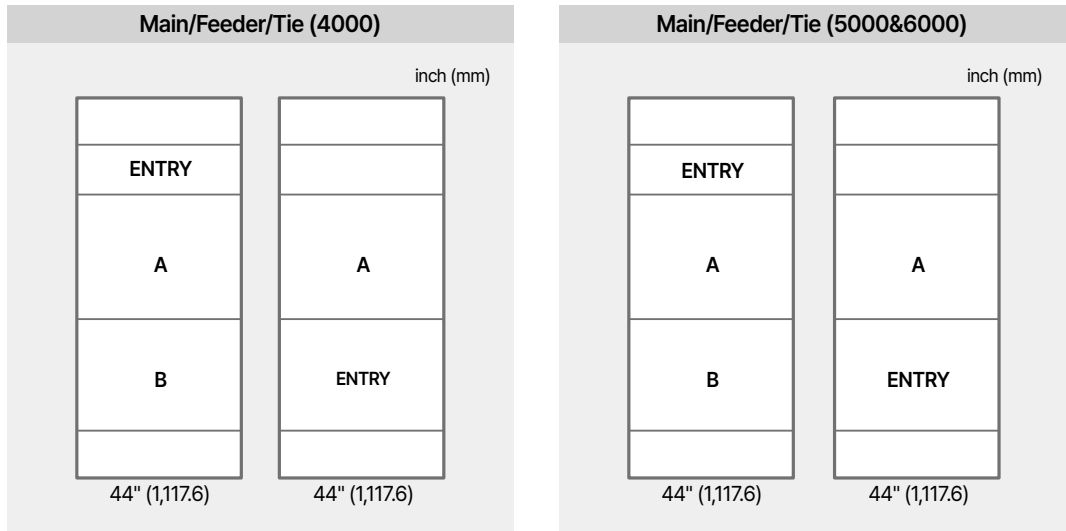

#### Available ampacity

Comp.	Available ampacity
A	4000/5000/6000
B	Blank, Instrument, LV compartment
Entry	Cable or busduct entry (Top and bottom available)

#### Dimensions

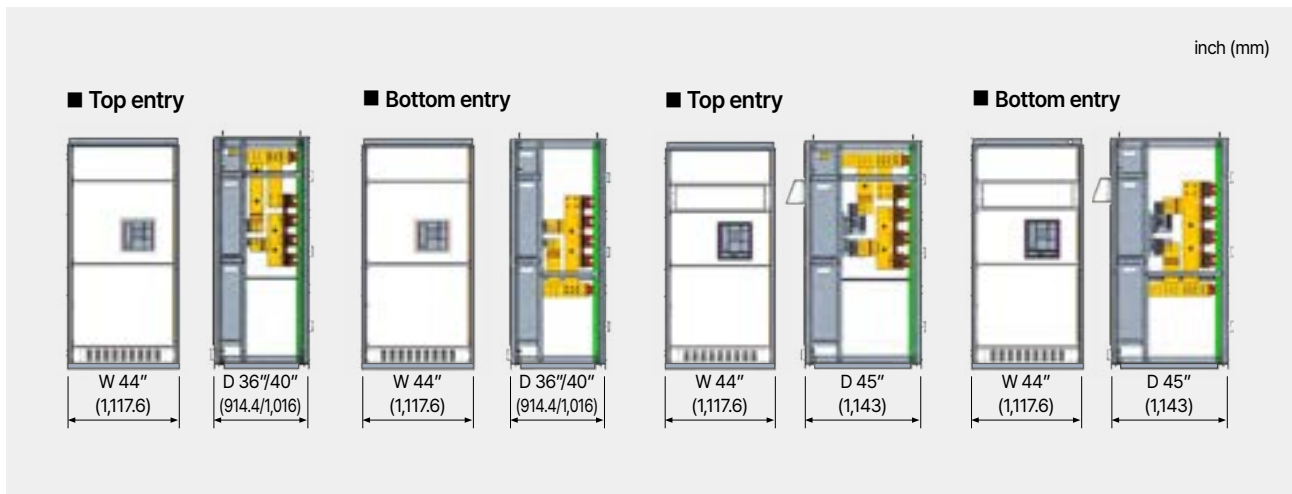

## Aluminum bus system (E-frame 2000, 2500, 3200A)

### Features

- Main / feeder tie circuit breaker: up to 3200A
- Enclosure size( Min. W×H×D):  
32"×90"×26" (812.8×2281.2×660.4mm)
- Bus rating: Main bus and vertical bus up to 100kA
- Available in top or bottom feed
- One stack layout only: The LSB Series can be configured as 2 or 4-stack. Please contact the LS ELECTRIC Sales and Engineering team for more information, referring to the LSB Switchboard Series catalog.

### Layout

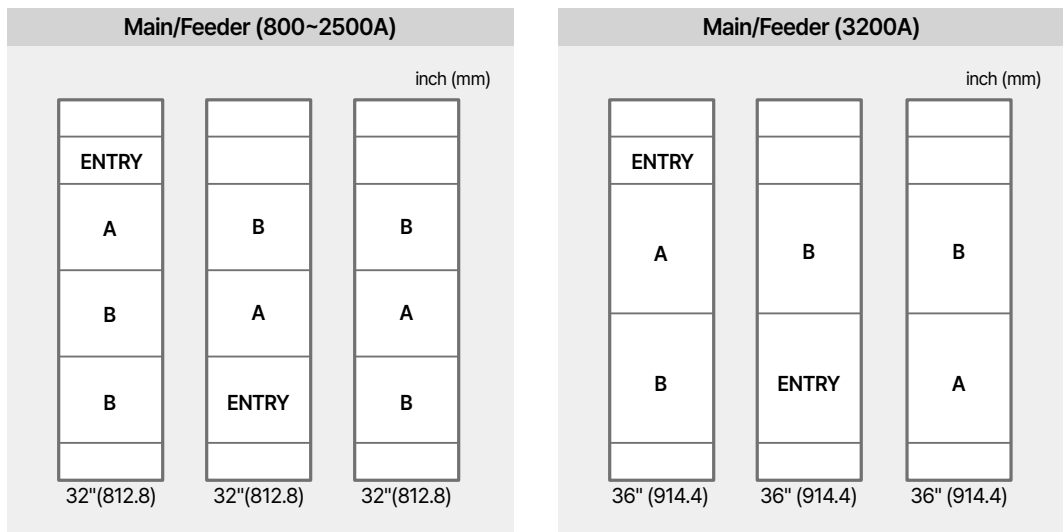

### Available ampacity

Comp.	Available ampacity W30" section	Available ampacity W36" section
A	~2000, 2500A	3200A
B	Blank, Instrument, LV compartment	
Entry	Cable or busduct entry (Top and bottom available)	

### Dimensions

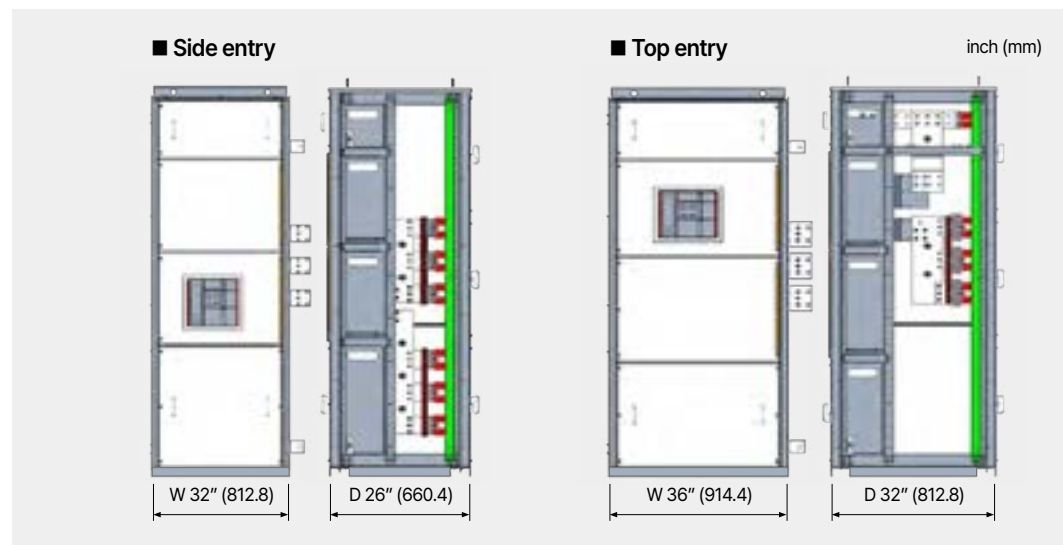

# Individually mounted section | LSB-i

## Layout based on in and out entry

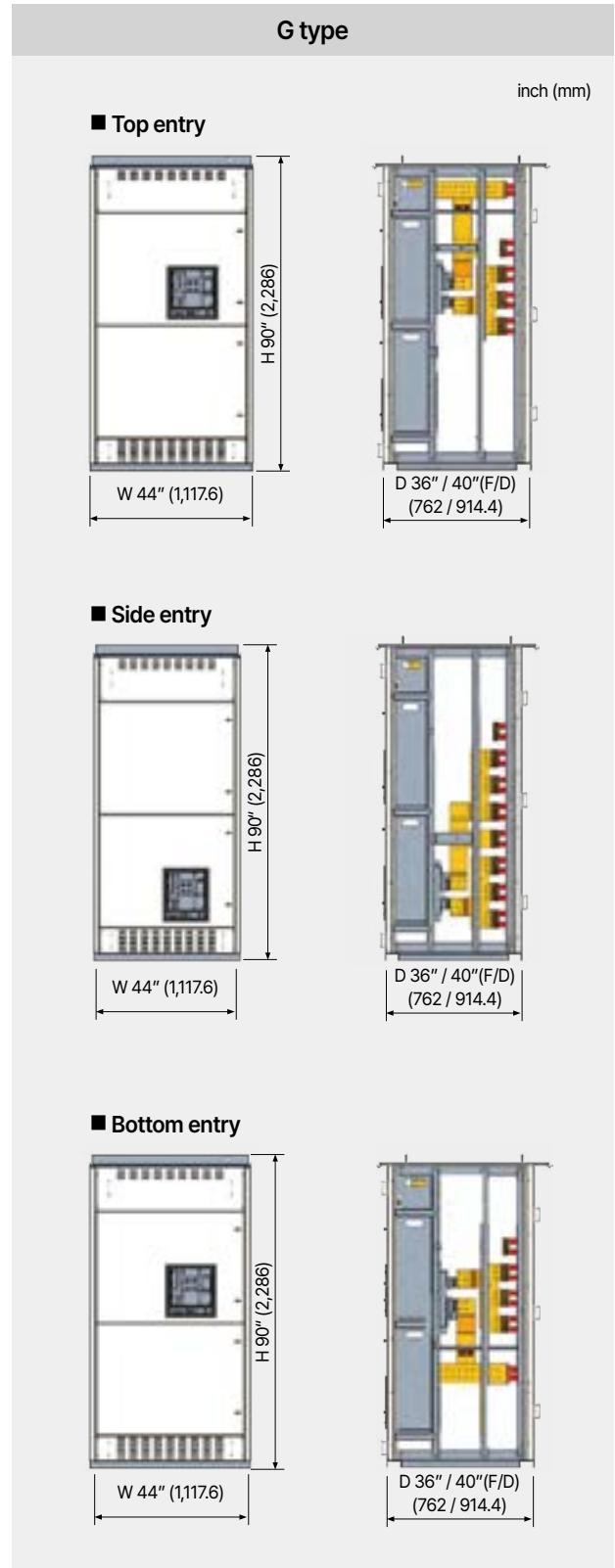
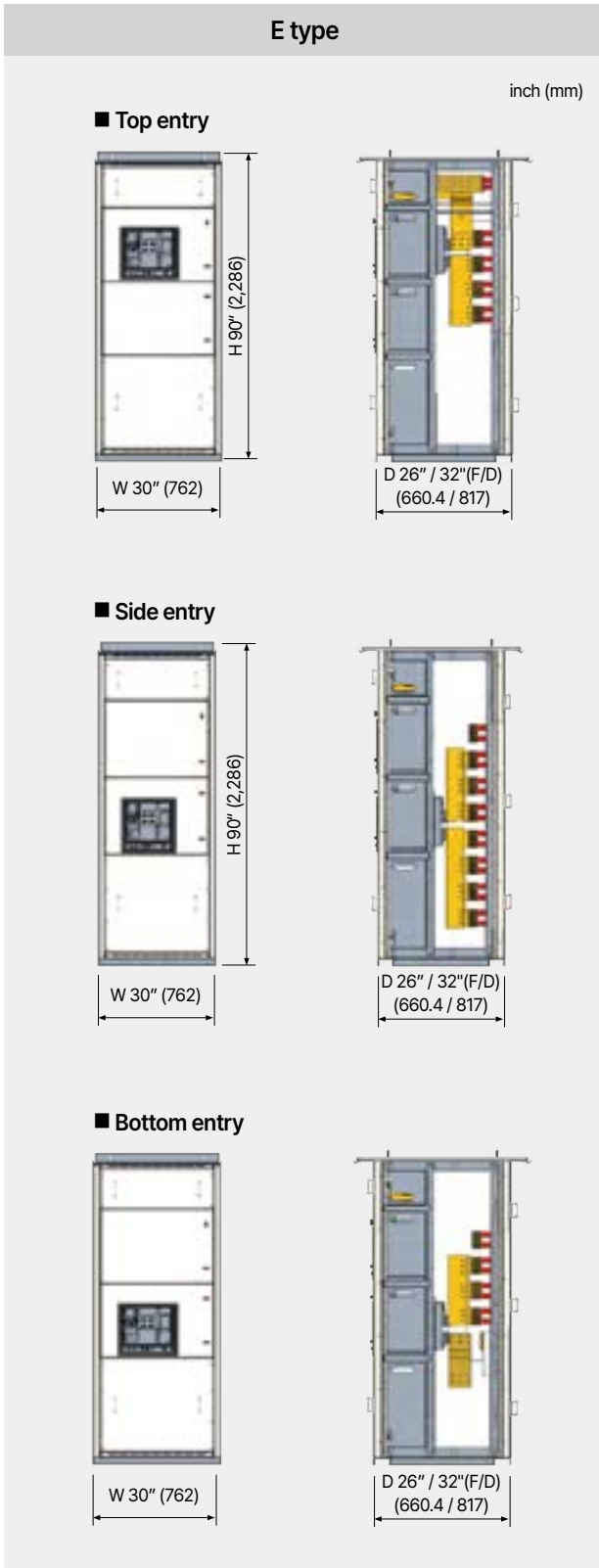

# Combination mounted section | LSB-C

## Description

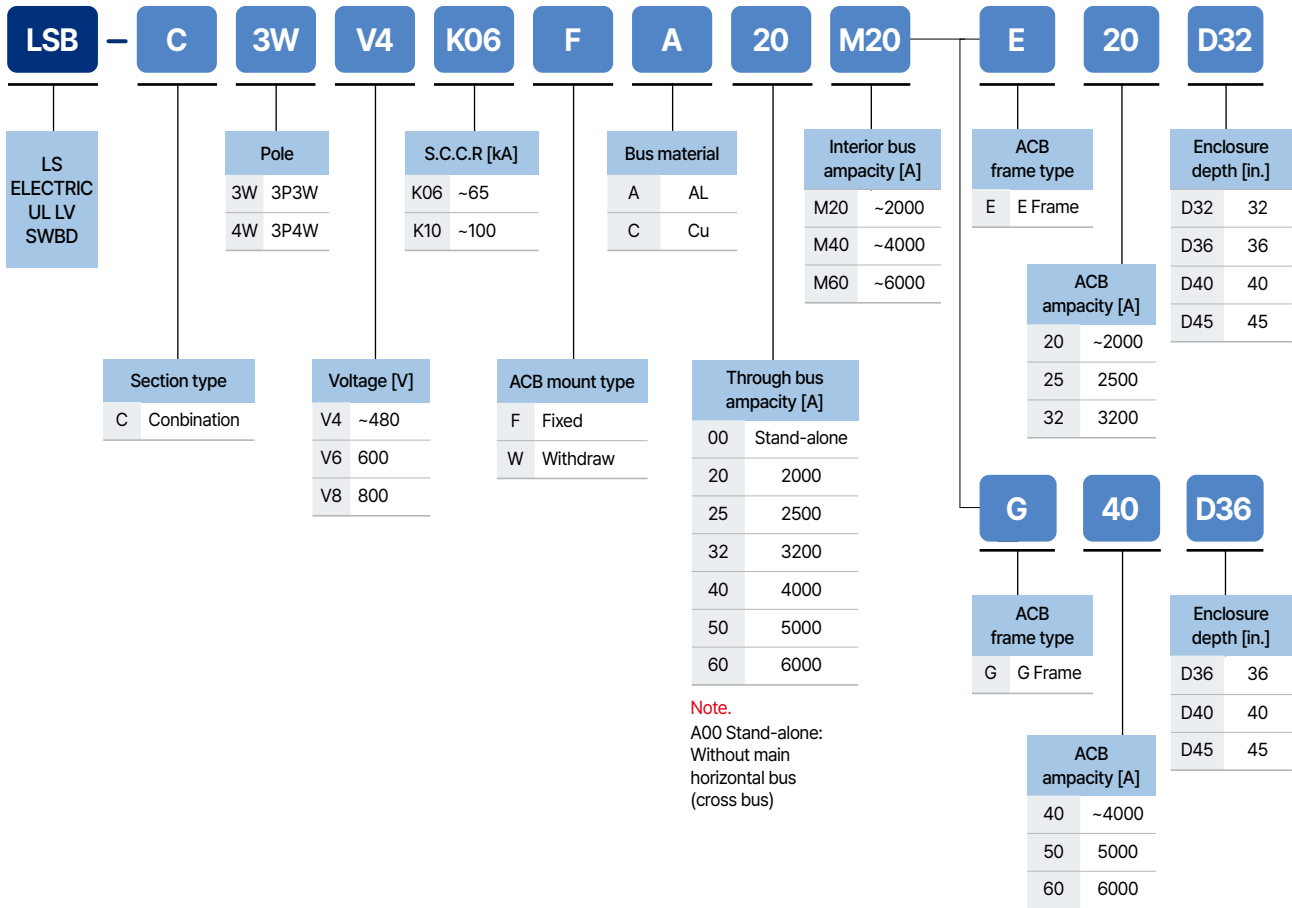

Table 1. Available depth of each section for device type and ampacity rating

ACB frame type	ACB ampacity	Mount type	Available Depth [in.] Through bus ampacity				
			2000A	2500A	3200A	4000A	5000&6000A
E	2000A	Fixed	26/32	26/32	32/36	36/40	45
		Draw-out	32	32	32/36	36/40	45
	2500A	Fixed	-	26/32	32/36	36/40	45
		Draw-out	-	32	32/36	36/40	45
	3200A	Fixed	-	-	32/36	36/40	45
		Draw-out	-	-	36	36/40	45
G	4000A	Fixed	-	-	-	36/40	45
		Draw-out	-	-	-	40	45
	5000&6000A	Fixed	-	-	-	-	-
		Draw-out	-	-	-	-	45
LSB-G series (Center feed incoming type, minimum depth)			26	26	32	36	45

**Note.**  
5000A/6000A ACB is available only in draw-out type

# Combination mounted section | LSB-C

## Layout and dimensions

### Copper / Aluminum bus system (E-frame 2000, 2500, 3200)

#### Features

- Main / feeder tie circuit breaker: up to 3200
  - Enclosure size (Min. W×H×D): 36"×90"×32" (1117.6 × 2281.2 × 914.4mm)
  - Bus rating: Main bus and vertical bus up to 100kA
  - ACB Feed : Top, MCCB Feed : Bottom
  - One stack layout only: The LSB Series can be configured as 2 or 4-stack. Please contact the LS ELECTRIC Sales and Engineering team for more information, referring to the LSB Switchboard Series catalog.
- \* Main busbar rating: Up to 6000 A (Copper) Up to 4000 A (Aluminum)

#### Layout

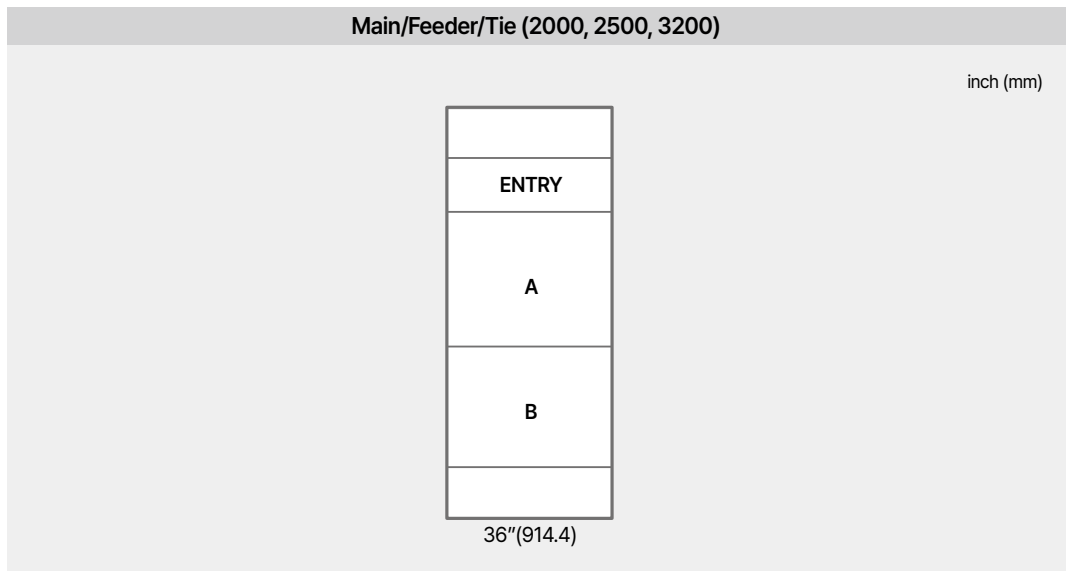

#### Available ampacity

Comp.	Available ampacity
A	2000, 2500, 3200
B	Interior : ~6000A
Entry	Cable or busduct entry (Top and bottom available)

#### Dimensions

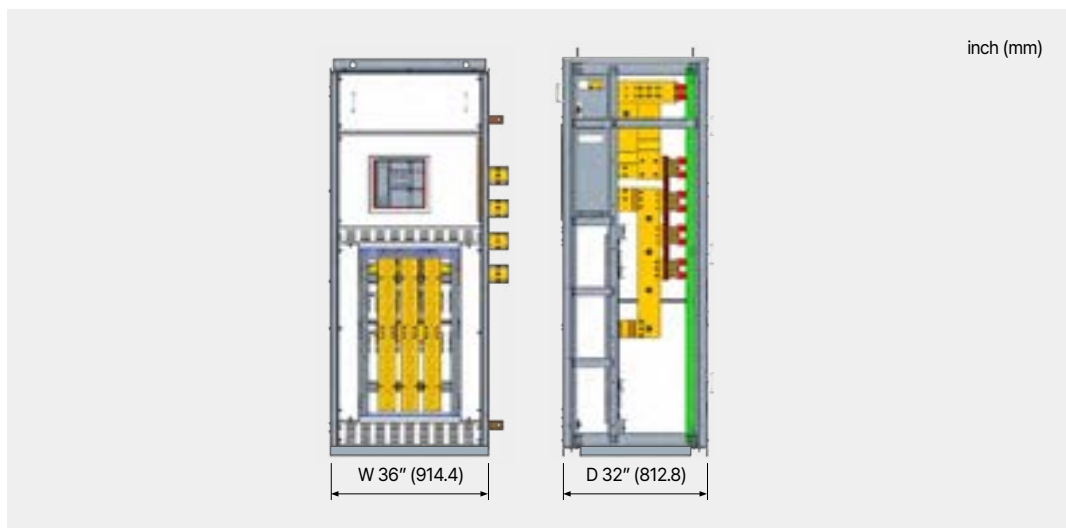

## Copper / Aluminum bus system (G Frame 4000, 5000, 6000A)

### Features

- Main / feeder tie circuit breaker: up to 6000
  - Enclosure size( Min. W×H×D): 44"×90"×36" (1117.6 × 2281.2 × 914.4mm)
  - Bus rating: Main bus and vertical bus up to 100kA
  - ACB Feed : Top, MCCB Feed : Bottom
  - One stack layout only: The LSB Series can be configured as 2 or 4-stack. Please contact the LS ELECTRIC Sales and Engineering team for more information, referring to the LSB Switchboard Series catalog.
- \* Main busbar rating: Up to 6000 A (Copper) Up to 4000 A (Aluminum)

### Layout

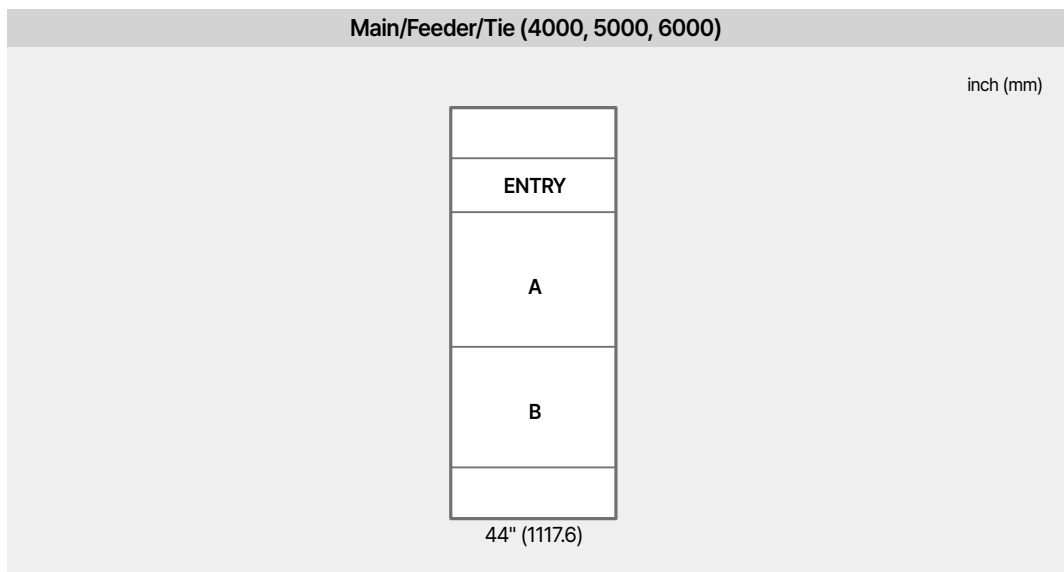

### Available ampacity

Comp.	Available ampacity
A	4000, 5000, 6000
B	Interior : ~6000A
Entry	Cable or busduct entry (Top and bottom available)

### Dimensions

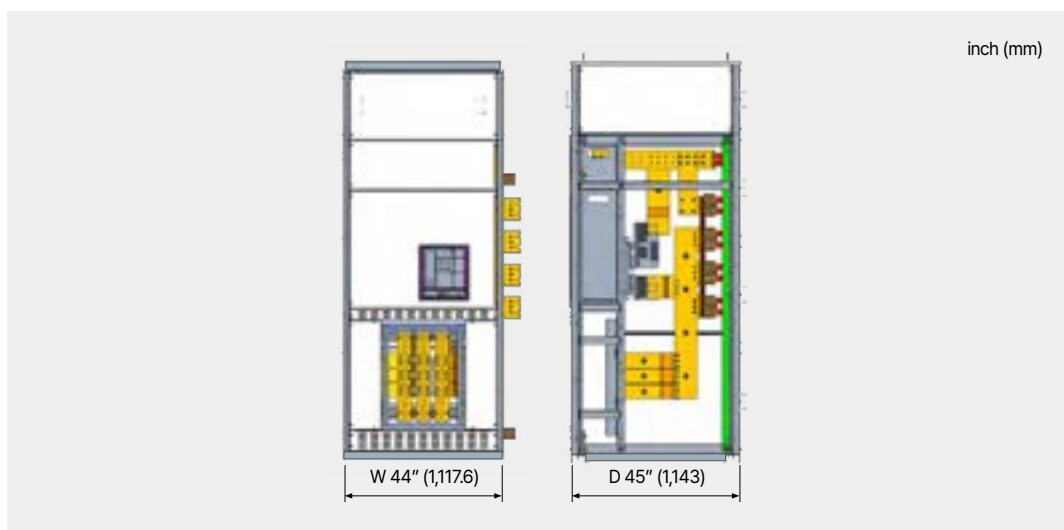

# Combination mounted section | LSB-C

## Layout and dimensions\_Stand-alone

Copper / Aluminum bus system (E-frame 2000, 2500, 3200)

### Features

- Main / feeder tie circuit breaker: up to 3200
- Enclosure size( Min. W×H×D): 36"×90"×26" (1117.6 × 2281.2 × 914.4mm)
- Bus rating: Main bus and vertical bus up to 100kA
- ACB Feed : Top, MCCB Feed : Top only
- One stack layout only: The LSB Series can be configured as 2 or 4-stack. Please contact the LS ELECTRIC Sales and Engineering team for more information, referring to the LSB Switchboard Series catalog.

### Layout

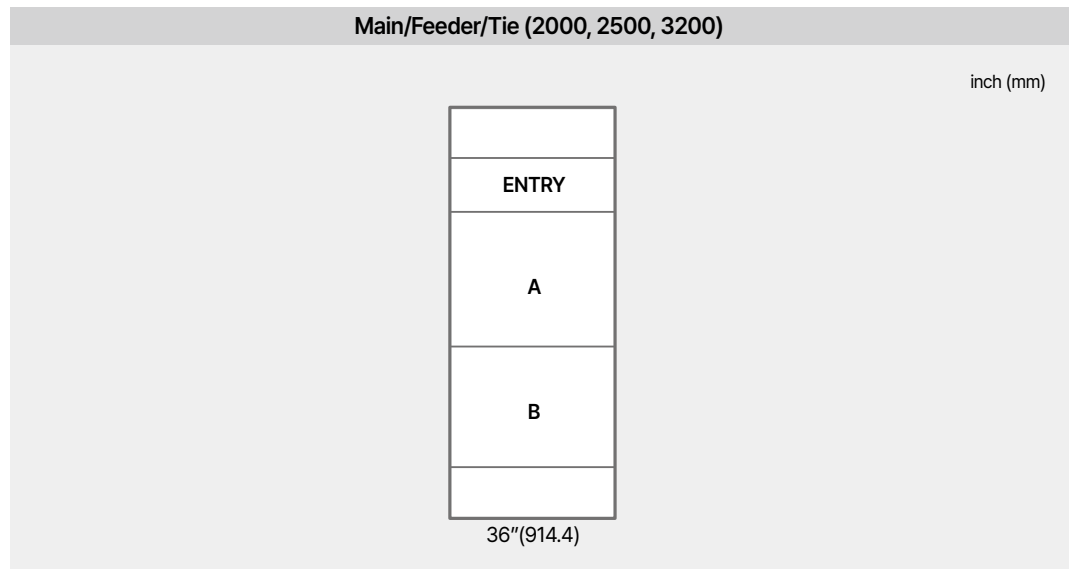

### Available ampacity

Comp.	Available ampacity
A	2000, 2500, 3200
B	Interior : ~6000A
Entry	Cable or busduct entry (Top and bottom available)

### Dimensions

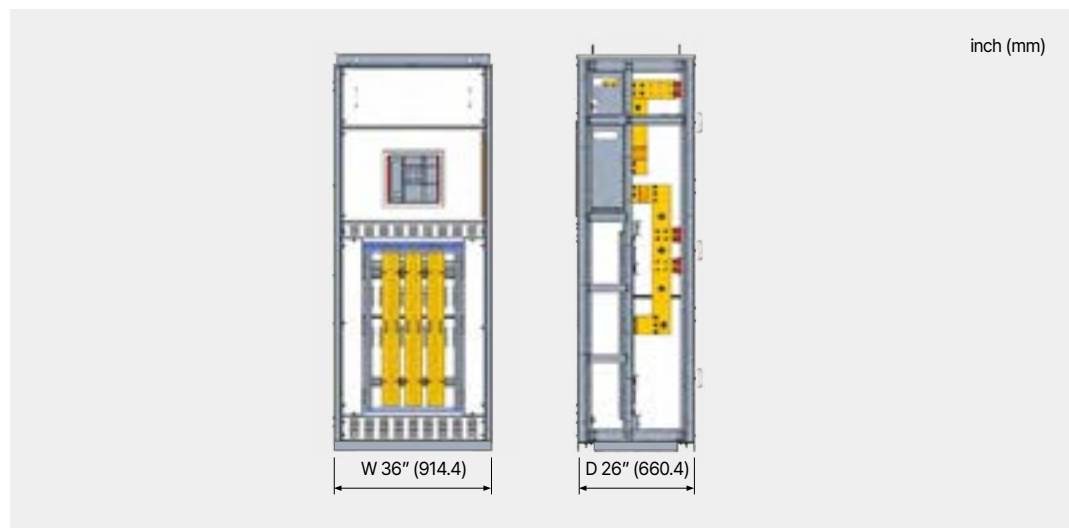

## Copper / Aluminum bus system (G Frame 4000, 5000, 6000A)

### Features

- Main / feeder tie circuit breaker: up to 6000
  - Enclosure size( Min. W×H×D): 44"×90"×32" (1117.6 × 2281.2 × 914.4mm)
  - Bus rating: Main bus and vertical bus up to 100kA
  - ACB Feed : Top, MCCB Feed : Top only
  - One stack layout only: The LSB Series can be configured as 2 or 4-stack. Please contact the LS ELECTRIC Sales and Engineering team for more information, referring to the LSB Switchboard Series catalog.
- \* Aluminum bus system can be design up to 4000A

### Layout

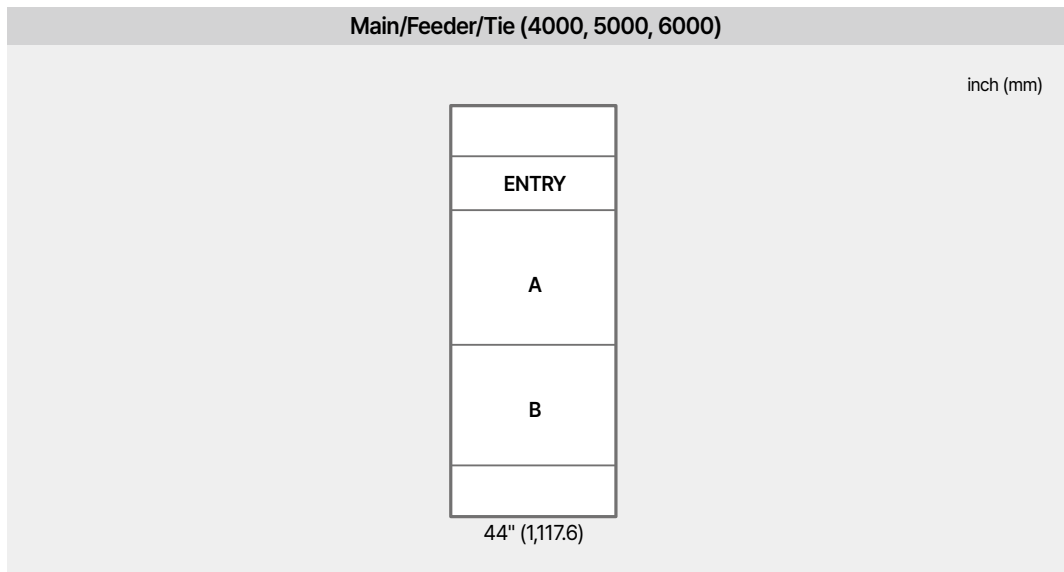

### Available ampacity

Comp.	Available ampacity
A	4000, 5000, 6000
B	Interior : ~6000A
Entry	Cable or busduct entry (Top and bottom available)

### Dimensions

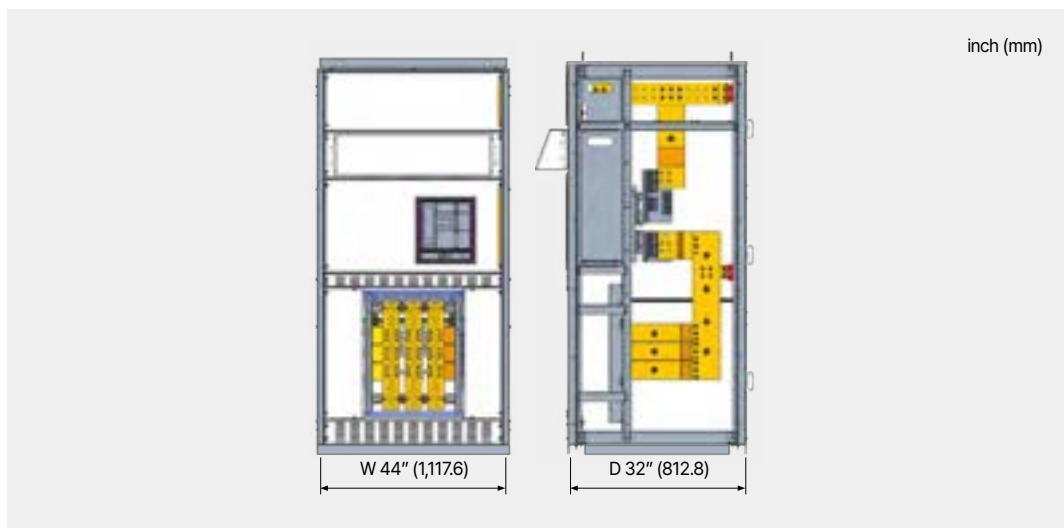

# Group mounted section | LSB-G

## Description

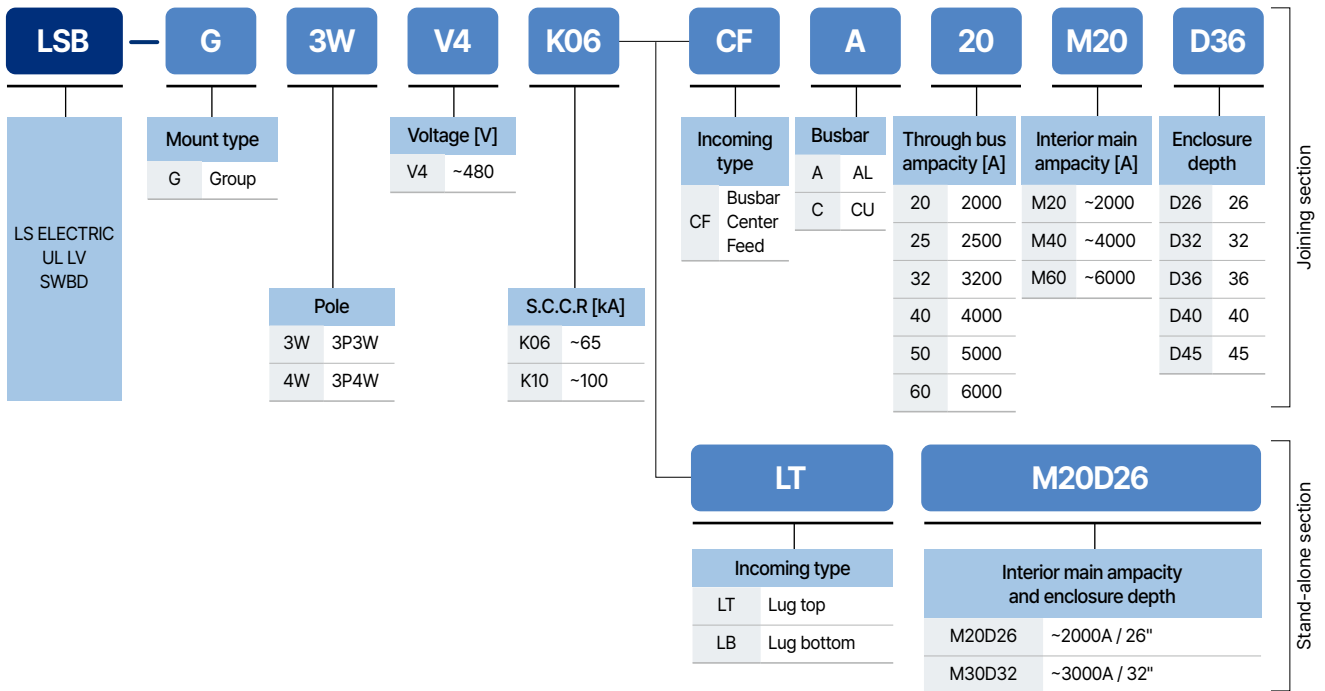

Table 1. Available depth of each section for device type and ampacity rating

ACB frame type	ACB ampacity	Mount type	Available Depth [in.] Through bus ampacity				
			2000A	2500A	3200A	4000A	5000&6000A
E	2000A	Fixed	26/32	26/32	32/36	36/40	45
		Draw-out	32	32	32/36	36/40	45
	2500A	Fixed	-	26/32	32/36	36/40	45
		Draw-out	-	32	32/36	36/40	45
G	3200A	Fixed	-	-	32/36	36/40	45
		Draw-out	-	-	36	36/40	45
	4000A	Fixed	-	-	-	36/40	45
		Draw-out	-	-	-	40	45
5000&6000A	Fixed	-	-	-	-	-	
	Draw-out	-	-	-	-	45	
LSB-G series (Center feed incoming type, minimum depth)			26	26	32	36	45

When joining other LSB series sections side by side, consider the minimum depth size of the sections being joined. To align the enclosures (front and rear) within the group, select the depth of the section with the largest depth size in the group. For center feed layout group-mounted sections, the minimum depth is 36". Please refer to Table 1.

- Note.** 1) The minimum width size for LSB-Group mounted sections is 36", but SKD products only provide a width of 42". If another width size (36", 46" or 50") is required, please contact LS ELECTRIC sales or engineering team.  
 2) Main lug only sections cannot be selected for K06.  
 3) LSB-G includes interior, and Bus Strap Kit must be purchased separately. Refer to page 40-41.  
 4) 5000A/6000A ACB is available only in draw-out type

## Layout and dimensions

### MCCB Group mounted section (2000, 4000, 6000A)

#### Features

- Interior rated current: 2000/4000/6000 A
- Up to 1200A breaker mounted as a branch device
- Double branched 100, 150 and 250AF breakers
- Interior maximum short circuit current rating: 100kA at 480Vac
- Individual breaker protection cover plates are provided
- Bus strap kits are ordered separately according to the MCCB rating
- Blank filler plate heights are from 2X to 9X
- Enclosure size (Min. W x H x D): 42" x 90" x 36" (1066.8 x 2281.2 x 914.4mm)

#### Layout (Interior)

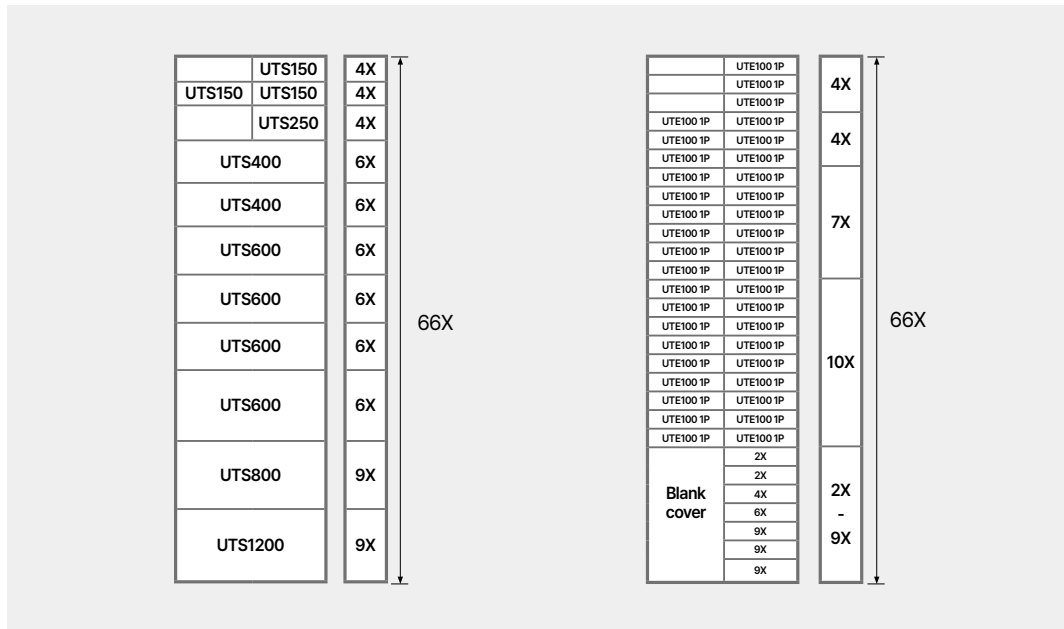

#### Cable entry size

(Top & bottom view)

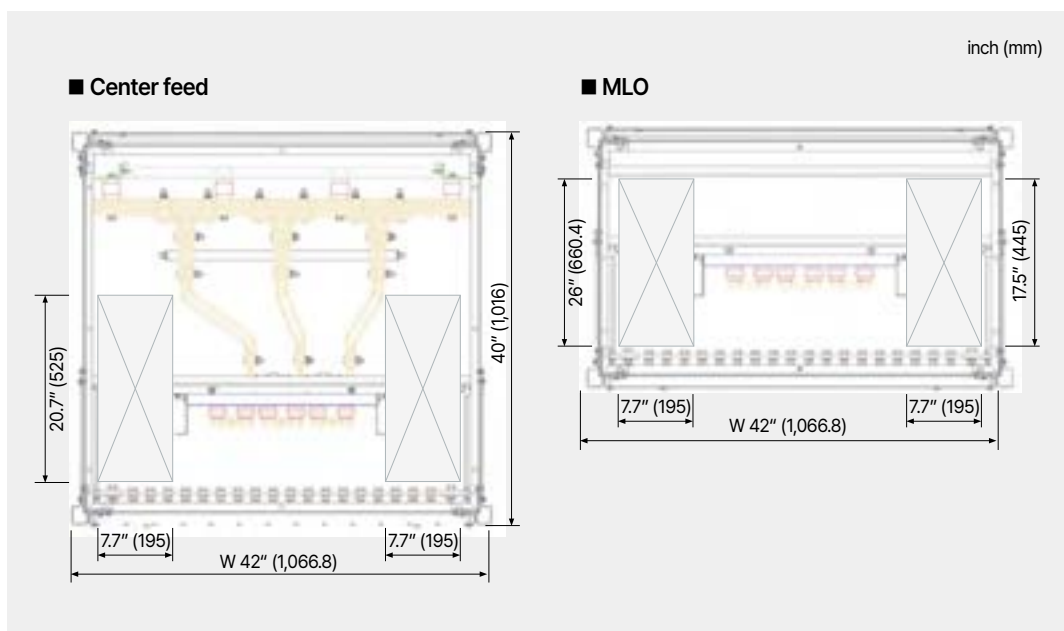

# Group mounted section | LSB-G

## Layout and dimensions

### MCCB Group mounted section (2000, 4000, 6000A)

#### Dimensions (Interior)

Description		Interior-2000	Interior-4000	Interior-6000
Rated current		2000A	4000A	6000A
Rated short-circuit breaking capacity		100kA @ 480Vac		
Applicable MCCB		UTE100, UTS150, UTS250, UTS400, UTS600, UTS800, UTS1200		
Frame size		66X	66X	66X
mm	W	542	542	562
	H	1995.8	1995.8	1995.8
	D	92	92	127.3
inch	W	21.34	21.34	22.13
	H	78.57	78.57	78.57
	D	3.62	3.62	5.01
Standard		UL891		

#### Dimensions (Switchboard)

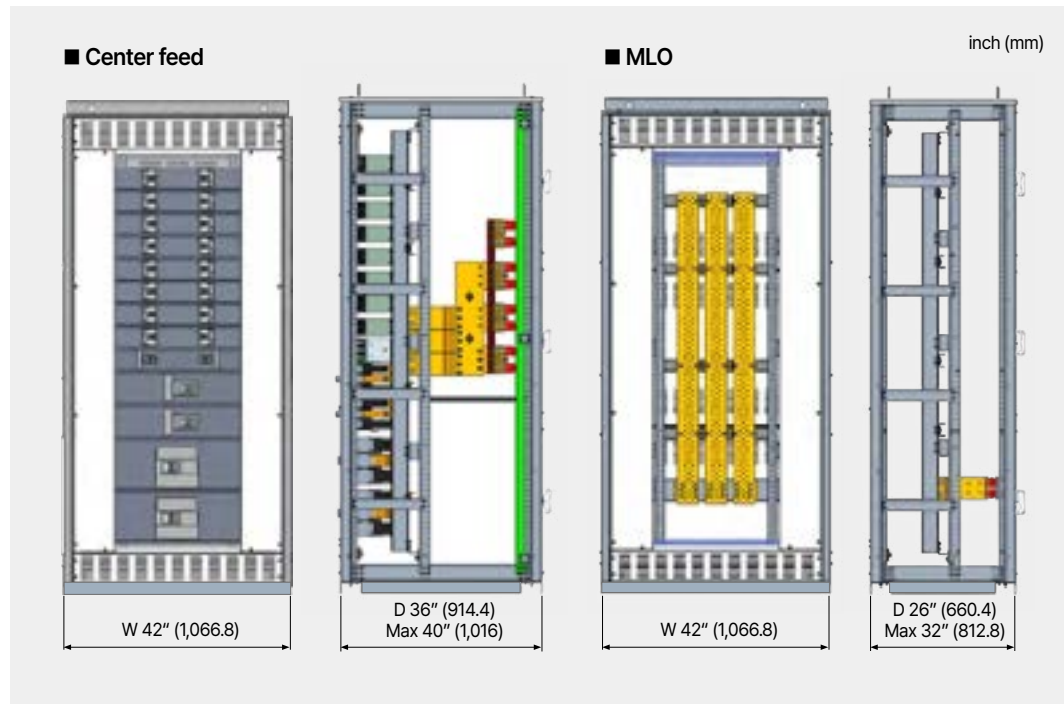

# Interior | INT

## Description

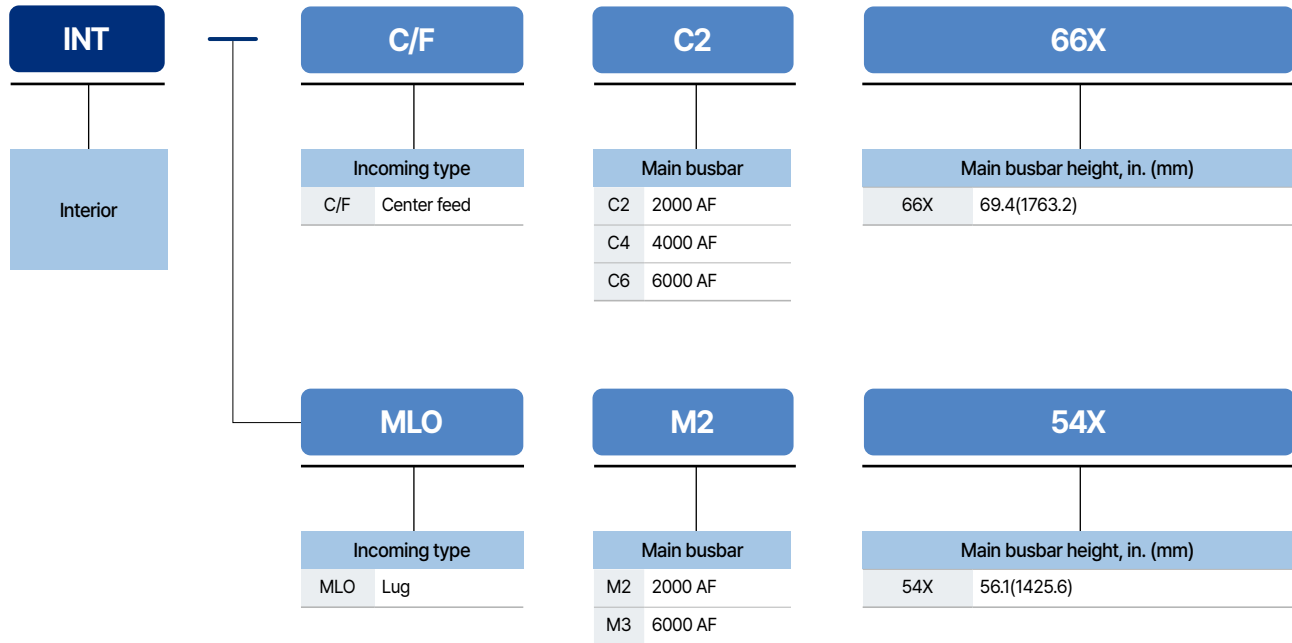

**Note.**  
INT includes only the interior and does not include the enclosure, BSK must be purchased separately. Refer to page 73.

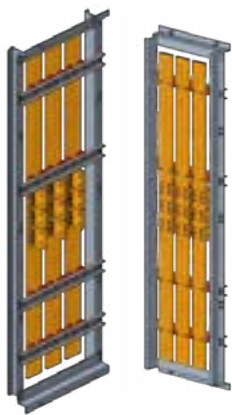

### Component Code (Interior)

Incoming type	Designation	Main busbar ampacity [A]	Main busbar height	Item code
Center feed	INT-C/FC2-66X	2000	66X	66173401001
	INT-C/FC4-66X	4000	66X	66173401002
	INT-C/FC6-66X	6000	66X	66173401003
Main lug only	INT-MLOM2-54X	2000	54X	66173401004
	INT-MLOM3-54X	3000	54X	66173401005

# Bus strap kit | BSK

## Description

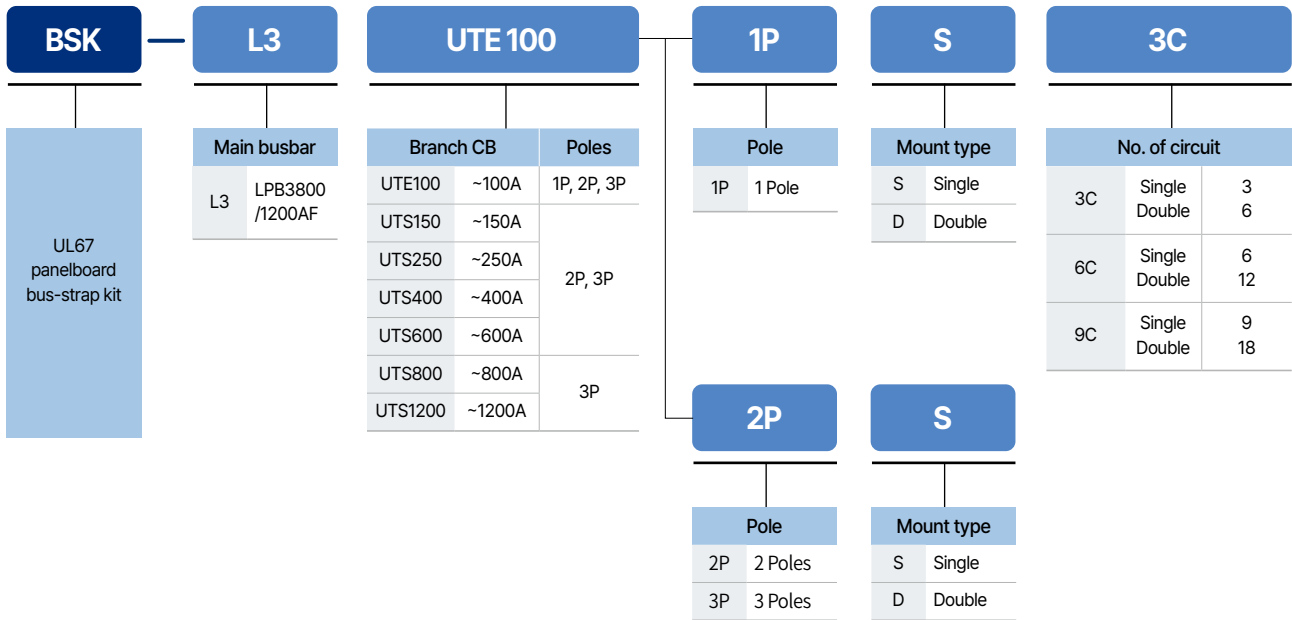

## Bus strap kit selection



BSK LPB-3 UTE100 1P single 3C

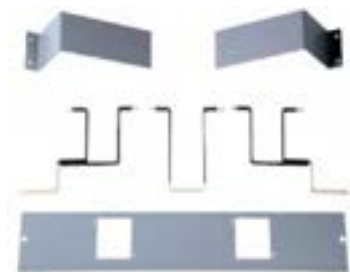

BSK LPB-3 UTE100 1P double 3C

Branch breaker				BSK Information	
Frame	Poles	X Units	Side	Description	Item code
UTE100	1	4	Single	BSK L3 UTE100 1P S 3C <sup>1)</sup>	7014007200
UTE100	1	7	Single	BSK L3 UTE100 1P S 6C <sup>1)</sup>	7014007300
UTE100	1	10	Single	BSK L3 UTE100 1P S 9C <sup>1)</sup>	7014007400
UTE100	1	4	Double	BSK L3 UTE100 1P D 3C <sup>1)</sup>	7014007500
UTE100	1	7	Double	BSK L3 UTE100 1P D 6C <sup>1)</sup>	7014007600
UTE100	1	10	Double	BSK L3 UTE100 1P D 9C <sup>1)</sup>	7014007700
UTE100	2	2	Single	BSK L3 UTE100 2P S	7014007800
UTE100	2	2	Double	BSK L3 UTE100 2P D	7014007900
UTE100	3	3	Single	BSK L3 UTE100 3P S	7014008000
UTE100	3	3	Double	BSK L3 UTE100 3P D	7014008100
UTS150	2, 3	4	Single	BSK L3 UTS150 3P S	7014008200
UTS150	2, 3	4	Double	BSK L3 UTS150 3P D	7014008300
UTS250	2, 3	4	Single	BSK L3 UTS250 3P S	7014008400
UTS250	2, 3	4	Double	BSK L3 UTS250 3P D	7014008500
UTS400	2, 3	6	Single	BSK L3 UTS400 3P S	7014008600
UTS600	2, 3	6	Single	BSK L3 UTS600 3P S	7014008800
UTS800	3	6	Single	BSK L3 UTS800 3P S	7014008900
UTS1200	3	6	Single	BSK L3 UTS1200 3P S	7014009000

Note. 1) Based on the installation of 3, 6 or 9 UTE100 1P units on a single side

\* Based on the installation of 6, 12 or 18 UTE100 1P units on a double side

### Neutral kit selection

- Applies only to the main lug only section

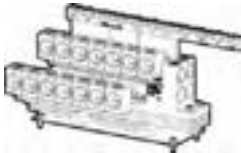

Neutral KIT L2 L0600 51P

Lug information		Neutral kit information description	Item code
Incoming lug	Neutral pole number		
(4) 3/0-600 kcmil (Cu)	(10) 1/0-600 kcmil, (11) #8-1/0 and (30) #14-#6 (51 Holes total)	Neutral KIT L3 MLO L1200 51P	7016001100

### Ground kit selection

- Applies only to the main lug only section



Ground KIT L2 L0125 82P

Lug information		Neutral kit information description	Item code
Incoming lug	Neutral pole number		
(1) #6-2/0 (Cu)	2 sets of (11) #8-1/0 and (30) #14-#6 (82 Holes total)	Ground KIT L3 L0125 82P	7017001000

### Accessory kit selection

- Blank covers used to seal spaces where branch breakers are not installed
- Filler covers are used for single mounting in the double mounting type of the UTS150 and UTS250

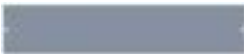

Bolted blank cover 2X-4X

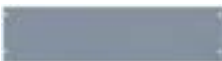

Bolted blank cover 5X-9X



Bolted filler cover

Branch breaker			Blank and filler cover information		
Frame	Poles	X units	Description	Item code	MOQ
		2	Acc KIT BLANK L3 2X (10EA) EXP	7019000900	10
		3	Acc KIT BLANK L3 3X (10EA) EXP	7019001000	10
		4	Acc KIT BLANK L3 4X (10EA) EXP	7019001100	10
		5	Acc KIT BLANK L3 5X (10EA) EXP	7019001200	10
		6	Acc KIT BLANK L3 6X (5EA) EXP	7019001300	5
		7	Acc KIT BLANK L3 7X (5EA) EXP	7019001400	5
		8	Acc KIT BLANK L3 8X (5EA) EXP	7019001500	5
		9	Acc KIT BLANK L3 9X (5EA) EXP	7019001600	5
UTS150 UTS250	2, 3		Acc KIT FILLER L3 UTS250 (10EA) EXP	7019002400	10



## Section lineup



### Individually mounted section: E type aluminum, side-entry

After receiving the OEM switchboard, remove the packaging to check the assembly as shown in the left illustration. Please order the ACBs separately according to the required ratings and assemble them by referring to the work manual (Manual\_ACB\_Assembly\_WorkOrder). The manual can be downloaded from the LSPE-X documentation.



### Combination mounted section : G type copper 6000A

After receiving the OEM switchboard, remove the packaging to check the assembly as shown in the left illustration. Verify the intended feeder rating and order the BSK kit and MCCB accordingly. Please assemble each separately packaged component accurately in accordance with the work manual. The manual can be downloaded from the LSPE-X documentation.



### Group mounted section : 6000A copper

After receiving the OEM switchboard, remove the packaging to check the assembly as shown in the left illustration. Verify the intended feeder rating and order the BSK kit and MCCB accordingly. Please assemble each separately packaged component accurately in accordance with the work manual. The manual can be downloaded from the LSPE-X documentation.



### Service equipment section : 6000A copper

After receiving the OEM switchboard, remove the packaging to check the assembly as shown in the left illustration. The service equipment section is shipped with the N-phase barrier, disconnect link, and main bonding jumper fully assembled. Pre-drilled NEMA pattern holes for cable installation are provided along with bolts. Since the holes follow the NEMA-specified diameter, they can be adapted for bolts that are convenient for use.

# LSPE-X user manual

## Definition and key features

### LSPE-X

<https://lspe-x.ls-electric.com>



### Definition

LSPE-X is a web-based digital platform designed to efficiently configure, quote, and document switchboards based on UL standards. This system supports OEMs in assembling and selling switchboards within LS ELECTRIC's certification scope. LSPE-X goes beyond simple component supply by providing integrated support for configuration, quotation, documentation, and assembly guidance.

### Key features

#### Web-based configuration and real-time quotation

Users can configure switchboard specifications through option selection on the LSPE-X web platform. The auto-disable function for incompatible items prevents design errors. Once the configuration is complete, an integrated quotation is automatically generated for pricing purposes.

#### Documentation and data provision

The platform automatically outputs quotations, manuals, drawings, and manuals.

#### Assembly and certification support

LSPE-X provides product-specific work instructions to enhance assembly efficiency.

#### Flexible delivery options

Individual components and sub-assemblies are supplied as standard, enabling response to diverse project requirements. Customers can select the optimal assembly and delivery strategy based on project size and complexity.

### Expected benefits

By enabling OEMs to handle design, quotation, assembly, and certification within a single platform, LSPE-X delivers benefits such as reduced lead time, minimized design errors, and automated documentation.

## Specification selection & quotation process

### Step 1. Generate project



- 1 Click this button to add a new project.  
Enter your desired name to set the project name.
- 2 Use this button to proceed to the next step after completing the current settings

### Step 2. Generate quote list



- 1 Click this button to add a new group.  
Enter your desired name to set the order name.
- 2 Use this button to proceed to the next step after completing the current settings.

### Step 3. Select product

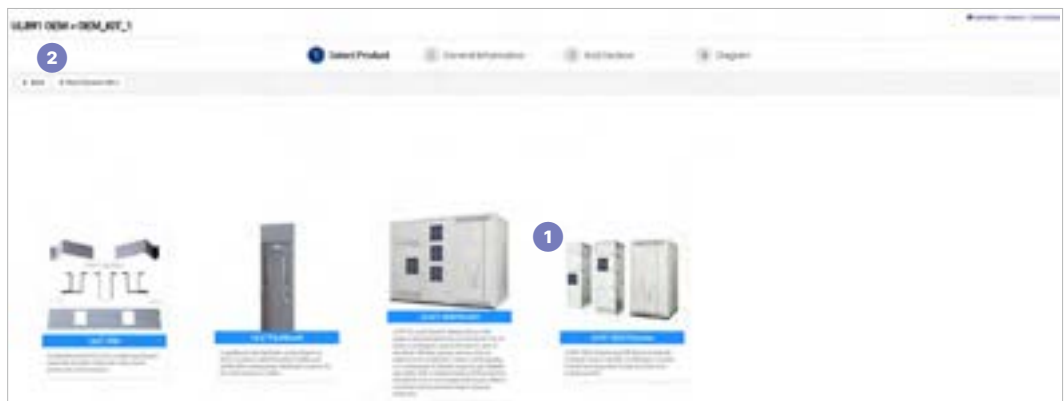

- 1 Select the desired product and click the button.
- 2 Use this button to proceed to the next step after completing the current settings.

### Step 4. General information



- 1 Select the desired specifications from the list.  
Make sure to select them sequentially from top to bottom.  
If you need to modify the selected specifications, **be sure to click the Clear button and reselect them.**
- 2 Use this button to proceed to the next step after completing the current settings.

# LSPE-X user manual

## Specification selection & quotation process

### Step 5. Add section

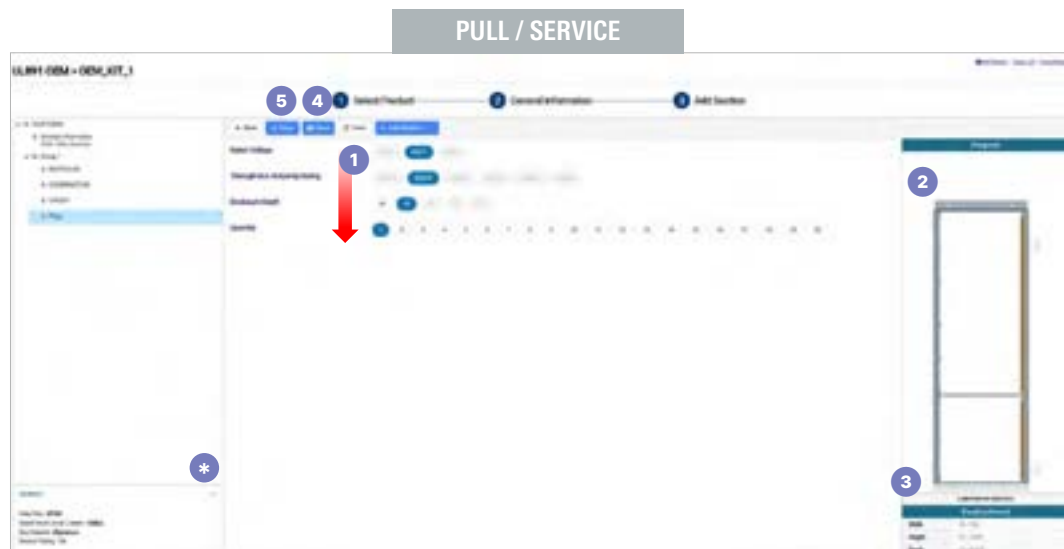
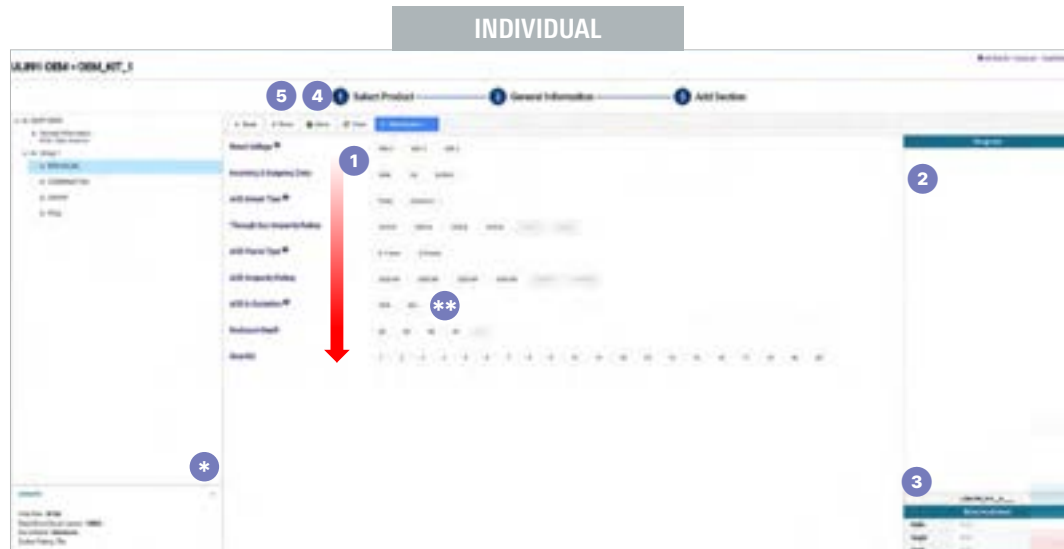

- 1 Select the desired specifications from the list.  
Make sure to select them sequentially from top to bottom.  
If you need to modify the selected specifications, **be sure to click the Clear button and reselect them.**
  - 2 Once all specifications have been selected, the diagram of the selected product will appear in this area.
  - 3 Once all specifications have been selected, the description of the selected section will be shown.
  - 4 Please **select all specifications** and use this button to save the current settings.
  - 5 Use this button to generate a quotation for the selected specifications.
- \* Clicking the arrow button allows you to view the General specifications you previously selected.
  - \*\* ACB in Quotation: ACB can be included in the quotation in **Individual** or **Combination** sections.  
The representative ACB is selected according to your specifications.  
For detailed ACB specifications, please contact Sales.  
Please note that **ACB is shipped UNASSEMBLED** in separate packages.

GROUP

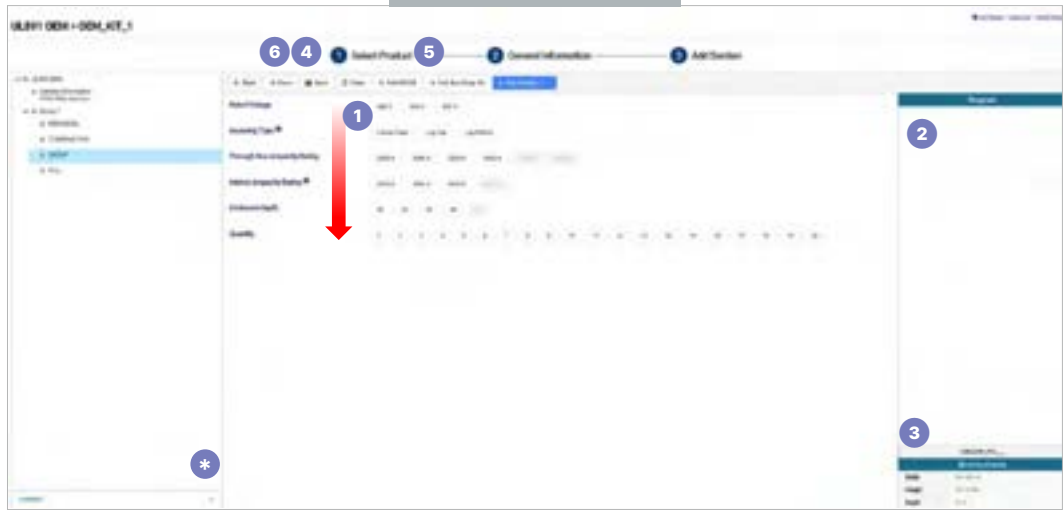

COMBINATION

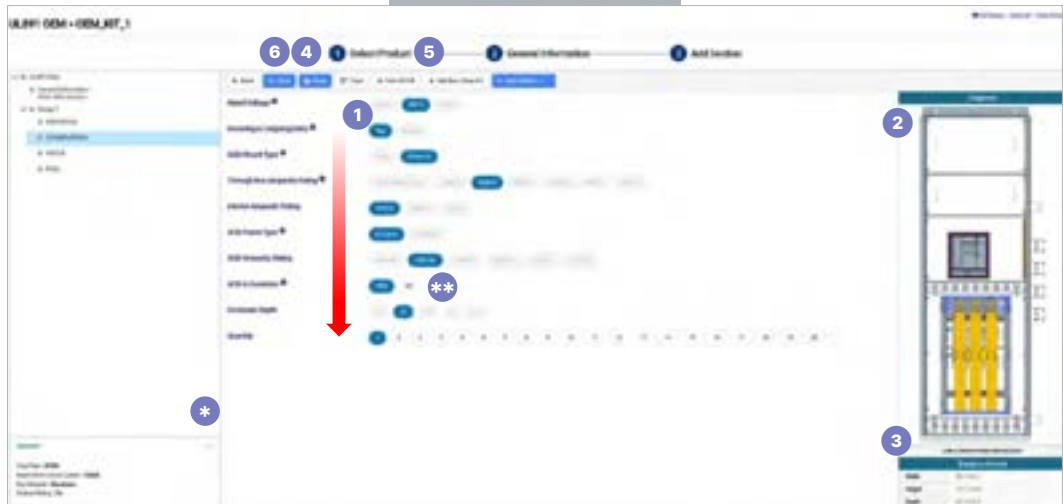

- 1 Select the desired specifications from the list.  
Make sure to select them sequentially from top to bottom.  
If you need to modify the selected specifications, **be sure to click the Clear button and reselect them.**
  - 2 Once all specifications have been selected, the diagram of the selected product will appear in this area.
  - 3 Once all specifications have been selected, the description of the selected section will be shown.
  - 4 Please **select all specifications** and use this button to save the current settings.
  - 5 Use this button to add MCCBs and Bus Strap Kits (BSKs) to your selection.  
MCCBs and BSKs can be added as needed to meet your specifications.  
Review your project requirements carefully and select the desired quantities.  
In addition, **these are shipped UNASSEMBLED in separate packages.**
  - 6 Use this button to generate a quotation for the selected specifications.
- \* Clicking the arrow button allows you to view the General specifications you previously selected.
  - \*\* ACB in Quotation: ACB can be included in the quotation in **Individual** or **Combination** sections.  
The representative ACB is selected according to your specifications.  
For detailed ACB specifications, please contact Sales.  
Please note that **ACB is shipped UNASSEMBLED in separate packages.**

# LSPE-X user manual

## Specification selection & quotation process

### Step 6. Option Select



#### Option selection and additional features

Available options vary depending on the higher-level specifications. Options that cannot be selected will appear in gray and be disabled. When saved, the selected specifications are recorded in each section.

- Hovering the mouse cursor over the question mark icon will display additional information about the specification.

### Step 7. Quotation download

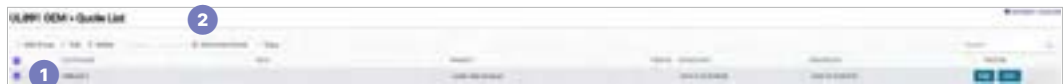

- 1 Select the product you wish to include in the quotation.
- 2 Click Download Center to generate and download the quotation.

Files Downloaded When Clicking **Download Center** (Quote Package)

#### Quotation (PROJECT NAME-LSPE-DATE.pdf):

The quotation includes detailed pricing information for the selected specifications.

#### Manual (MANUAL.folder):

These manuals provide information for all products.

Please make sure to refer to the manual corresponding to the specifications you have selected.

The manual includes the following documents:

- IOM Manual ([UL\_LV\_SWBD]\_IOM\_Manual\_EN\_T800M2-02-202405.pdf)
- ACB Assembly Manual (Manual\_ACB\_Assembly\_WorkOrder.pdf)
- BSK Assembly Manual (Manual\_Bus Strap Kit.zip)
- P-cover Assembly Manual (Manual\_LPB3\_INTERIOR\_EN\_202401.pdf)

#### Drawing (DRAWING.folder):

The drawing contains diagrams showing the structure and layout of the selected product.

## Quotation

### Quotation proposal



Quote No: LSPE-251114-0028  
Quote Date : 11/14/2025

To: 1  
Attr: 11

This proposal will remain valid in effect for 30 days unless changed in the interim upon written notice by LS Electric.

Prepared by: 1  
Team: 1  
Email: 1  
Quote #: LSPE-251114-0028

**LS ELECTRIC AMERICA offer for [UL891 OEM] – [SCOPE OVERVIEW]:**

Dear 1

Thank you for this opportunity for LS Electric to participate in this project. We are pleased to submit our offer below for your consideration:

**Switchboard General Information**

Item No.	Qty	Product	Description
OEM_KIT_1	1	UL891 OEM Structure	Pole/Wire - 3P4W Rated Short Circuit Current - 65kA Bus Material - Copper Busbar Plating - Tin

**\* 1. Scope of Supply**

**Dimension**

OEM\_KIT\_1

- (1)- 36" Wide Section(s)
- (1)- 42" Wide Section(s)
- (1)- 44" Wide Section(s)
- (3)- 36" Deep Enclosure(s)

Total Dimensions : 122"W X 90"H X 36"D

Approximate Weight: 141.01 lbs / (63.96 kgs)

### General information

Check the Description in the table to ensure that the selected product and specifications are correct. If the specifications do not match your selection, please contact the sales team.

#### \* 1. Scope of supply

**Dimension:** Indicates the width and depth of each section.

**Total Dimensions:** Shows the width, depth, and height when all selected sections are combined.

**Approximate Weight:** Displays the total weight of the selected sections.

# LSPE-X user manual

## Quotation

### Incoming requirements

Quote No: LSPE-251114-0028  
Quote Date : 11/14/2025

**LS ELECTRIC**  
Incoming Requirements

Enclosure Properties					
No.	Section Type	Description	(Q'ty)	Item Code	Total Price
OEM_KIT_1					
#1	INDIVIDUAL	LSB-I4WV4K065FC40G40D36	(1)	9105146700	\$ 72,212.80
		UAH-40G3-40V,4000AF/4000AT,Fixed,3P,Trip Relay(L5IG),UL	(1)	29280241UL	\$ 16,755.82
		LSB-G4WV4K06CFC40M40D36	(1)	9106006900	\$ 76,627.43
		UTS150H FMU 150A 3P LO UL	(2)	02070110UL	\$ 4,234.72
		UTS250H ATU 250A 3P LO UL	(2)	02090077UL	\$ 6,764.68
		UTS400H ETS33 LI 400A 3P LO UL	(2)	02110713UL	\$ 13,550.26
		UTS600H ETS33 LI 600A 3P LO UL	(1)	02130719UL	\$ 11,104.21
		UTS1200H AR1 800A 3P LO UL	(1)	02145545UL	\$ 21,142.23
		UTS1200H AR1 1200A 3P LO UL	(1)	02145617UL	\$ 21,142.23
		#2	GROUP	BSK L3 UTS150 3P D	(1)
BSK L3 UTS250 3P D	(1)			7014008500	\$ 2,990.67
BSK L3 UTS400 3P S	(2)			7014008600	\$ 4,757.94
BSK L3 UTS600 3P S	(1)			7014008800	\$ 2,915.33
BSK L3 UTS1200 3P S	(1)			7014009000	\$ 4,372.75
BSK L3 UTS1200 3P S	(1)			7014009000	\$ 4,372.75
LSB-P4WV4K06C40D36	(1)			9107007100	\$ 55,476.30

**Selected Specifications**

- ↳ General Information
- ↳ Design
- ↳ PERIPHERAL
- ↳ GROUP
- ↳ SA00B
- ↳ SA00C
- ↳ SA00D
- ↳ SA00E
- ↳ SA00F
- ↳ SA00G
- ↳ SA00H
- ↳ SA00I
- ↳ SA00J
- ↳ SA00K
- ↳ SA00L
- ↳ SA00M
- ↳ SA00N
- ↳ SA00O
- ↳ SA00P
- ↳ SA00Q
- ↳ SA00R
- ↳ SA00S
- ↳ SA00T
- ↳ SA00U
- ↳ SA00V
- ↳ SA00W
- ↳ SA00X
- ↳ SA00Y
- ↳ SA00Z
- ↳ SA00AA
- ↳ SA00AB
- ↳ SA00AC
- ↳ SA00AD
- ↳ SA00AE
- ↳ SA00AF
- ↳ SA00AG
- ↳ SA00AH
- ↳ SA00AI
- ↳ SA00AJ
- ↳ SA00AK
- ↳ SA00AL
- ↳ SA00AM
- ↳ SA00AN
- ↳ SA00AO
- ↳ SA00AP
- ↳ SA00AQ
- ↳ SA00AR
- ↳ SA00AS
- ↳ SA00AT
- ↳ SA00AU
- ↳ SA00AV
- ↳ SA00AW
- ↳ SA00AX
- ↳ SA00AY
- ↳ SA00AZ
- ↳ SA00BA
- ↳ SA00BB
- ↳ SA00BC
- ↳ SA00BD
- ↳ SA00BE
- ↳ SA00BF
- ↳ SA00BG
- ↳ SA00BH
- ↳ SA00BI
- ↳ SA00BJ
- ↳ SA00BK
- ↳ SA00BL
- ↳ SA00BM
- ↳ SA00BN
- ↳ SA00BO
- ↳ SA00BP
- ↳ SA00BQ
- ↳ SA00BR
- ↳ SA00BS
- ↳ SA00BT
- ↳ SA00BU
- ↳ SA00BV
- ↳ SA00BW
- ↳ SA00BX
- ↳ SA00BY
- ↳ SA00BZ
- ↳ SA00CA
- ↳ SA00CB
- ↳ SA00CC
- ↳ SA00CD
- ↳ SA00CE
- ↳ SA00CF
- ↳ SA00CG
- ↳ SA00CH
- ↳ SA00CI
- ↳ SA00CJ
- ↳ SA00CK
- ↳ SA00CL
- ↳ SA00CM
- ↳ SA00CN
- ↳ SA00CO
- ↳ SA00CP
- ↳ SA00CQ
- ↳ SA00CR
- ↳ SA00CS
- ↳ SA00CT
- ↳ SA00CU
- ↳ SA00CV
- ↳ SA00CW
- ↳ SA00CX
- ↳ SA00CY
- ↳ SA00CZ
- ↳ SA00DA
- ↳ SA00DB
- ↳ SA00DC
- ↳ SA00DD
- ↳ SA00DE
- ↳ SA00DF
- ↳ SA00DG
- ↳ SA00DH
- ↳ SA00DI
- ↳ SA00DJ
- ↳ SA00DK
- ↳ SA00DL
- ↳ SA00DM
- ↳ SA00DN
- ↳ SA00DO
- ↳ SA00DP
- ↳ SA00DQ
- ↳ SA00DR
- ↳ SA00DS
- ↳ SA00DT
- ↳ SA00DU
- ↳ SA00DV
- ↳ SA00DW
- ↳ SA00DX
- ↳ SA00DY
- ↳ SA00DZ
- ↳ SA00EA
- ↳ SA00EB
- ↳ SA00EC
- ↳ SA00ED
- ↳ SA00EE
- ↳ SA00EF
- ↳ SA00EG
- ↳ SA00EH
- ↳ SA00EI
- ↳ SA00EJ
- ↳ SA00EK
- ↳ SA00EL
- ↳ SA00EM
- ↳ SA00EN
- ↳ SA00EO
- ↳ SA00EP
- ↳ SA00EQ
- ↳ SA00ER
- ↳ SA00ES
- ↳ SA00ET
- ↳ SA00EU
- ↳ SA00EV
- ↳ SA00EW
- ↳ SA00EX
- ↳ SA00EY
- ↳ SA00EZ
- ↳ SA00FA
- ↳ SA00FB
- ↳ SA00FC
- ↳ SA00FD
- ↳ SA00FE
- ↳ SA00FF
- ↳ SA00FG
- ↳ SA00FH
- ↳ SA00FI
- ↳ SA00FJ
- ↳ SA00FK
- ↳ SA00FL
- ↳ SA00FM
- ↳ SA00FN
- ↳ SA00FO
- ↳ SA00FP
- ↳ SA00FQ
- ↳ SA00FR
- ↳ SA00FS
- ↳ SA00FT
- ↳ SA00FU
- ↳ SA00FV
- ↳ SA00FW
- ↳ SA00FX
- ↳ SA00FY
- ↳ SA00FZ
- ↳ SA00GA
- ↳ SA00GB
- ↳ SA00GC
- ↳ SA00GD
- ↳ SA00GE
- ↳ SA00GF
- ↳ SA00GG
- ↳ SA00GH
- ↳ SA00GI
- ↳ SA00GJ
- ↳ SA00GK
- ↳ SA00GL
- ↳ SA00GM
- ↳ SA00GN
- ↳ SA00GO
- ↳ SA00GP
- ↳ SA00GQ
- ↳ SA00GR
- ↳ SA00GS
- ↳ SA00GT
- ↳ SA00GU
- ↳ SA00GV
- ↳ SA00GW
- ↳ SA00GX
- ↳ SA00GY
- ↳ SA00GZ
- ↳ SA00HA
- ↳ SA00HB
- ↳ SA00HC
- ↳ SA00HD
- ↳ SA00HE
- ↳ SA00HF
- ↳ SA00HG
- ↳ SA00HH
- ↳ SA00HI
- ↳ SA00HJ
- ↳ SA00HK
- ↳ SA00HL
- ↳ SA00HM
- ↳ SA00HN
- ↳ SA00HO
- ↳ SA00HP
- ↳ SA00HQ
- ↳ SA00HR
- ↳ SA00HS
- ↳ SA00HT
- ↳ SA00HU
- ↳ SA00HV
- ↳ SA00HW
- ↳ SA00HX
- ↳ SA00HY
- ↳ SA00HZ
- ↳ SA00IA
- ↳ SA00IB
- ↳ SA00IC
- ↳ SA00ID
- ↳ SA00IE
- ↳ SA00IF
- ↳ SA00IG
- ↳ SA00IH
- ↳ SA00II
- ↳ SA00IJ
- ↳ SA00IK
- ↳ SA00IL
- ↳ SA00IM
- ↳ SA00IN
- ↳ SA00IO
- ↳ SA00IP
- ↳ SA00IQ
- ↳ SA00IR
- ↳ SA00IS
- ↳ SA00IT
- ↳ SA00IU
- ↳ SA00IV
- ↳ SA00IW
- ↳ SA00IX
- ↳ SA00IY
- ↳ SA00IZ
- ↳ SA00JA
- ↳ SA00JB
- ↳ SA00JC
- ↳ SA00JD
- ↳ SA00JE
- ↳ SA00JF
- ↳ SA00JG
- ↳ SA00JH
- ↳ SA00JI
- ↳ SA00JJ
- ↳ SA00JK
- ↳ SA00JL
- ↳ SA00JM
- ↳ SA00JN
- ↳ SA00JO
- ↳ SA00JP
- ↳ SA00JQ
- ↳ SA00JR
- ↳ SA00JS
- ↳ SA00JT
- ↳ SA00JU
- ↳ SA00JV
- ↳ SA00JW
- ↳ SA00JX
- ↳ SA00JY
- ↳ SA00JZ
- ↳ SA00KA
- ↳ SA00KB
- ↳ SA00KC
- ↳ SA00KD
- ↳ SA00KE
- ↳ SA00KF
- ↳ SA00KG
- ↳ SA00KH
- ↳ SA00KI
- ↳ SA00KJ
- ↳ SA00KK
- ↳ SA00KL
- ↳ SA00KM
- ↳ SA00KN
- ↳ SA00KO
- ↳ SA00KP
- ↳ SA00KQ
- ↳ SA00KR
- ↳ SA00KS
- ↳ SA00KT
- ↳ SA00KU
- ↳ SA00KV
- ↳ SA00KW
- ↳ SA00KX
- ↳ SA00KY
- ↳ SA00KZ
- ↳ SA00LA
- ↳ SA00LB
- ↳ SA00LC
- ↳ SA00LD
- ↳ SA00LE
- ↳ SA00LF
- ↳ SA00LG
- ↳ SA00LH
- ↳ SA00LI
- ↳ SA00LJ
- ↳ SA00LK
- ↳ SA00LL
- ↳ SA00LM
- ↳ SA00LN
- ↳ SA00LO
- ↳ SA00LP
- ↳ SA00LQ
- ↳ SA00LR
- ↳ SA00LS
- ↳ SA00LT
- ↳ SA00LU
- ↳ SA00LV
- ↳ SA00LW
- ↳ SA00LX
- ↳ SA00LY
- ↳ SA00LZ
- ↳ SA00MA
- ↳ SA00MB
- ↳ SA00MC
- ↳ SA00MD
- ↳ SA00ME
- ↳ SA00MF
- ↳ SA00MG
- ↳ SA00MH
- ↳ SA00MI
- ↳ SA00MJ
- ↳ SA00MK
- ↳ SA00ML
- ↳ SA00MM
- ↳ SA00MN
- ↳ SA00MO
- ↳ SA00MP
- ↳ SA00MQ
- ↳ SA00MR
- ↳ SA00MS
- ↳ SA00MT
- ↳ SA00MU
- ↳ SA00MV
- ↳ SA00MW
- ↳ SA00MX
- ↳ SA00MY
- ↳ SA00MZ
- ↳ SA00NA
- ↳ SA00NB
- ↳ SA00NC
- ↳ SA00ND
- ↳ SA00NE
- ↳ SA00NF
- ↳ SA00NG
- ↳ SA00NH
- ↳ SA00NI
- ↳ SA00NJ
- ↳ SA00NK
- ↳ SA00NL
- ↳ SA00NM
- ↳ SA00NN
- ↳ SA00NO
- ↳ SA00NP
- ↳ SA00NQ
- ↳ SA00NR
- ↳ SA00NS
- ↳ SA00NT
- ↳ SA00NU
- ↳ SA00NV
- ↳ SA00NW
- ↳ SA00NX
- ↳ SA00NY
- ↳ SA00NZ
- ↳ SA00OA
- ↳ SA00OB
- ↳ SA00OC
- ↳ SA00OD
- ↳ SA00OE
- ↳ SA00OF
- ↳ SA00OG
- ↳ SA00OH
- ↳ SA00OI
- ↳ SA00OJ
- ↳ SA00OK
- ↳ SA00OL
- ↳ SA00OM
- ↳ SA00ON
- ↳ SA00OO
- ↳ SA00OP
- ↳ SA00OQ
- ↳ SA00OR
- ↳ SA00OS
- ↳ SA00OT
- ↳ SA00OU
- ↳ SA00OV
- ↳ SA00OW
- ↳ SA00OX
- ↳ SA00OY
- ↳ SA00OZ
- ↳ SA00PA
- ↳ SA00PB
- ↳ SA00PC
- ↳ SA00PD
- ↳ SA00PE
- ↳ SA00PF
- ↳ SA00PG
- ↳ SA00PH
- ↳ SA00PI
- ↳ SA00PJ
- ↳ SA00PK
- ↳ SA00PL
- ↳ SA00PM
- ↳ SA00PN
- ↳ SA00PO
- ↳ SA00PP
- ↳ SA00PQ
- ↳ SA00PR
- ↳ SA00PS
- ↳ SA00PT
- ↳ SA00PU
- ↳ SA00PV
- ↳ SA00PW
- ↳ SA00PX
- ↳ SA00PY
- ↳ SA00PZ
- ↳ SA00QA
- ↳ SA00QB
- ↳ SA00QC
- ↳ SA00QD
- ↳ SA00QE
- ↳ SA00QF
- ↳ SA00QG
- ↳ SA00QH
- ↳ SA00QI
- ↳ SA00QJ
- ↳ SA00QK
- ↳ SA00QL
- ↳ SA00QM
- ↳ SA00QN
- ↳ SA00QO
- ↳ SA00QP
- ↳ SA00QQ
- ↳ SA00QR
- ↳ SA00QS
- ↳ SA00QT
- ↳ SA00QU
- ↳ SA00QV
- ↳ SA00QW
- ↳ SA00QX
- ↳ SA00QY
- ↳ SA00QZ
- ↳ SA00RA
- ↳ SA00RB
- ↳ SA00RC
- ↳ SA00RD
- ↳ SA00RE
- ↳ SA00RF
- ↳ SA00RG
- ↳ SA00RH
- ↳ SA00RI
- ↳ SA00RJ
- ↳ SA00RK
- ↳ SA00RL
- ↳ SA00RM
- ↳ SA00RN
- ↳ SA00RO
- ↳ SA00RP
- ↳ SA00RQ
- ↳ SA00RR
- ↳ SA00RS
- ↳ SA00RT
- ↳ SA00RU
- ↳ SA00RV
- ↳ SA00RW
- ↳ SA00RX
- ↳ SA00RY
- ↳ SA00RZ
- ↳ SA00SA
- ↳ SA00SB
- ↳ SA00SC
- ↳ SA00SD
- ↳ SA00SE
- ↳ SA00SF
- ↳ SA00SG
- ↳ SA00SH
- ↳ SA00SI
- ↳ SA00SJ
- ↳ SA00SK
- ↳ SA00SL
- ↳ SA00SM
- ↳ SA00SN
- ↳ SA00SO
- ↳ SA00SP
- ↳ SA00SQ
- ↳ SA00SR
- ↳ SA00SS
- ↳ SA00ST
- ↳ SA00SU
- ↳ SA00SV
- ↳ SA00SW
- ↳ SA00SX
- ↳ SA00SY
- ↳ SA00SZ
- ↳ SA00TA
- ↳ SA00TB
- ↳ SA00TC
- ↳ SA00TD
- ↳ SA00TE
- ↳ SA00TF
- ↳ SA00TG
- ↳ SA00TH
- ↳ SA00TI
- ↳ SA00TJ
- ↳ SA00TK
- ↳ SA00TL
- ↳ SA00TM
- ↳ SA00TN
- ↳ SA00TO
- ↳ SA00TP
- ↳ SA00TQ
- ↳ SA00TR
- ↳ SA00TS
- ↳ SA00TT
- ↳ SA00TU
- ↳ SA00TV
- ↳ SA00TW
- ↳ SA00TX
- ↳ SA00TY
- ↳ SA00TZ
- ↳ SA00UA
- ↳ SA00UB
- ↳ SA00UC
- ↳ SA00UD
- ↳ SA00UE
- ↳ SA00UF
- ↳ SA00UG
- ↳ SA00UH
- ↳ SA00UI
- ↳ SA00UJ
- ↳ SA00UK
- ↳ SA00UL
- ↳ SA00UM
- ↳ SA00UN
- ↳ SA00UO
- ↳ SA00UP
- ↳ SA00UQ
- ↳ SA00UR
- ↳ SA00US
- ↳ SA00UT
- ↳ SA00UU
- ↳ SA00UV
- ↳ SA00UW
- ↳ SA00UX
- ↳ SA00UY
- ↳ SA00UZ
- ↳ SA00VA
- ↳ SA00VB
- ↳ SA00VC
- ↳ SA00VD
- ↳ SA00VE
- ↳ SA00VF
- ↳ SA00VG
- ↳ SA00VH
- ↳ SA00VI
- ↳ SA00VJ
- ↳ SA00VK
- ↳ SA00VL
- ↳ SA00VM
- ↳ SA00VN
- ↳ SA00VO
- ↳ SA00VP
- ↳ SA00VQ
- ↳ SA00VR
- ↳ SA00VS
- ↳ SA00VT
- ↳ SA00VU
- ↳ SA00VV
- ↳ SA00VW
- ↳ SA00VX
- ↳ SA00VY
- ↳ SA00VZ
- ↳ SA00WA
- ↳ SA00WB
- ↳ SA00WC
- ↳ SA00WD
- ↳ SA00WE
- ↳ SA00WF
- ↳ SA00WG
- ↳ SA00WH
- ↳ SA00WI
- ↳ SA00WJ
- ↳ SA00WK
- ↳ SA00WL
- ↳ SA00WM
- ↳ SA00WN
- ↳ SA00WO
- ↳ SA00WP
- ↳ SA00WQ
- ↳ SA00WR
- ↳ SA00WS
- ↳ SA00WT
- ↳ SA00WU
- ↳ SA00WV
- ↳ SA00WW
- ↳ SA00WX
- ↳ SA00WY
- ↳ SA00WZ
- ↳ SA00XA
- ↳ SA00XB
- ↳ SA00XC
- ↳ SA00XD
- ↳ SA00XE
- ↳ SA00XF
- ↳ SA00XG
- ↳ SA00XH
- ↳ SA00XI
- ↳ SA00XJ
- ↳ SA00XK
- ↳ SA00XL
- ↳ SA00XM
- ↳ SA00XN
- ↳ SA00XO
- ↳ SA00XP
- ↳ SA00XQ
- ↳ SA00XR
- ↳ SA00XS
- ↳ SA00XT
- ↳ SA00XU
- ↳ SA00XV
- ↳ SA00XW
- ↳ SA00XX
- ↳ SA00XY
- ↳ SA00XZ
- ↳ SA00YA
- ↳ SA00YB
- ↳ SA00YC
- ↳ SA00YD
- ↳ SA00YE
- ↳ SA00YF
- ↳ SA00YG
- ↳ SA00YH
- ↳ SA00YI
- ↳ SA00YJ
- ↳ SA00YK
- ↳ SA00YL
- ↳ SA00YM
- ↳ SA00YN
- ↳ SA00YO
- ↳ SA00YP
- ↳ SA00YQ
- ↳ SA00YR
- ↳ SA00YS
- ↳ SA00YT
- ↳ SA00YU
- ↳ SA00YV
- ↳ SA00YW
- ↳ SA00YX
- ↳ SA00YY
- ↳ SA00YZ
- ↳ SA00ZA
- ↳ SA00ZB
- ↳ SA00ZC
- ↳ SA00ZD
- ↳ SA00ZE
- ↳ SA00ZF
- ↳ SA00ZG
- ↳ SA00ZH
- ↳ SA00ZI
- ↳ SA00ZJ
- ↳ SA00ZK
- ↳ SA00ZL
- ↳ SA00ZM
- ↳ SA00ZN
- ↳ SA00ZO
- ↳ SA00ZP
- ↳ SA00ZQ
- ↳ SA00ZR
- ↳ SA00ZS
- ↳ SA00ZT
- ↳ SA00ZU
- ↳ SA00ZV
- ↳ SA00ZW
- ↳ SA00ZX
- ↳ SA00ZY
- ↳ SA00ZZ

Pricing is fixed for the term of the quote; sales tax is excluded.  
Shipping costs are based on current rates and may change if rates increase.  
Detailed BOM and the Comments, Clarifications and Exceptions for more details.  
Training, instruction, and field services are NOT included as part of this price.  
Installation and maintenance may be provided at additional cost.

- 1 Ensure that the selected specifications match correctly.
- 2 For detailed ACB specifications, please contact the Sales team.  
The price shown in the quotation represents the representative price.
- 3 (Total Price) = (List Price) × (Q'ty)  
The displayed quotation shows the List Price,  
so please contact the sales team for an accurate final quotation.
- 4 The number in parentheses indicates the quantity of the selected product.

## Drawing

General assembly drawing

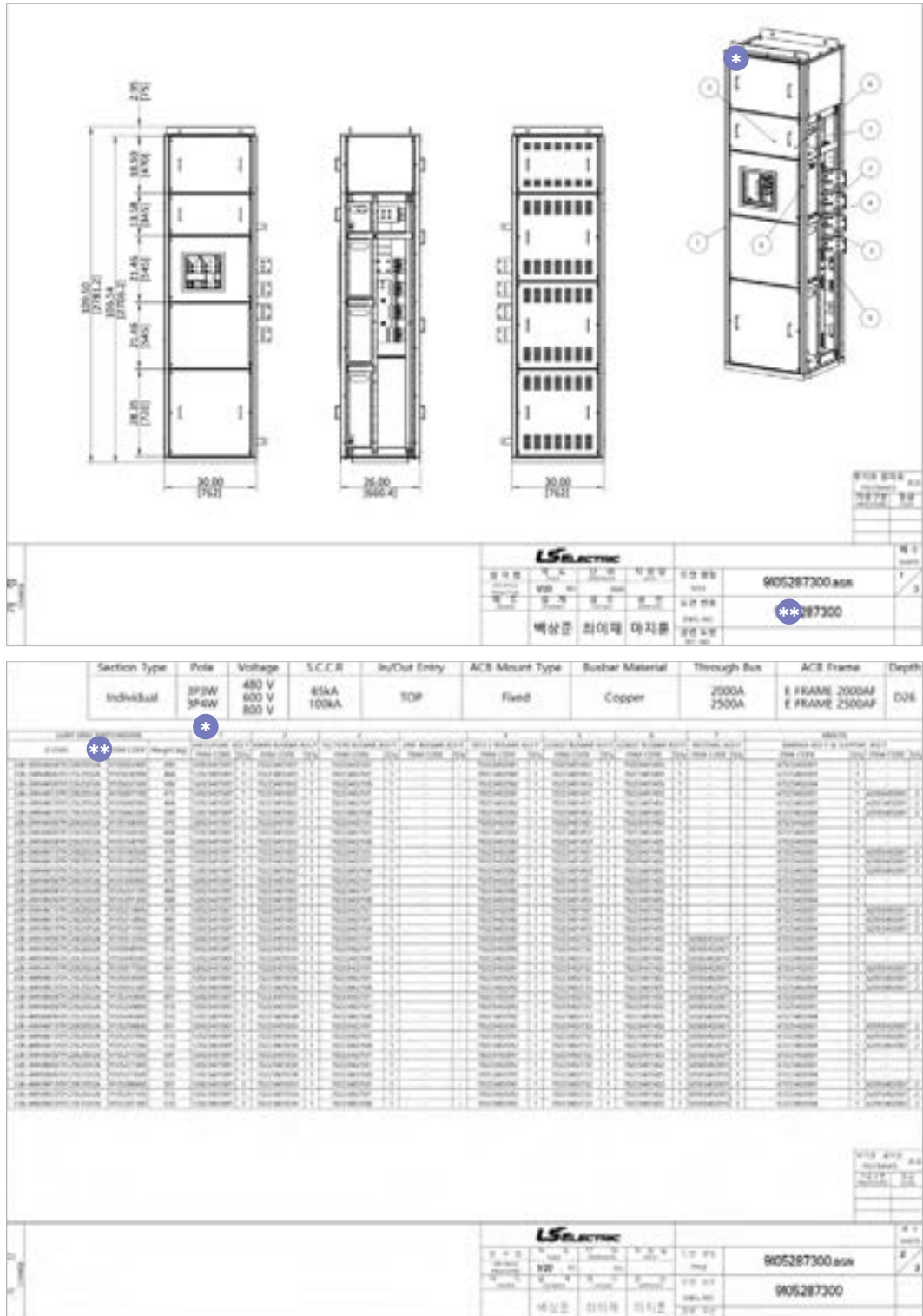

\* The balloons in the drawing represent BOM numbers.

\*\* The Item Code shown in the drawing may differ from the product you selected. This drawing is based on a representative model that uses the same enclosure. Exactly, the Item Code for the ordered product can be found on page 2 of the quotation.

# ***DIGITAL SUPPORT HUB***

***SCAN THE QR CODE FOR INSTANT PRODUCT INFORMATION AND EXPERT SUPPORT***

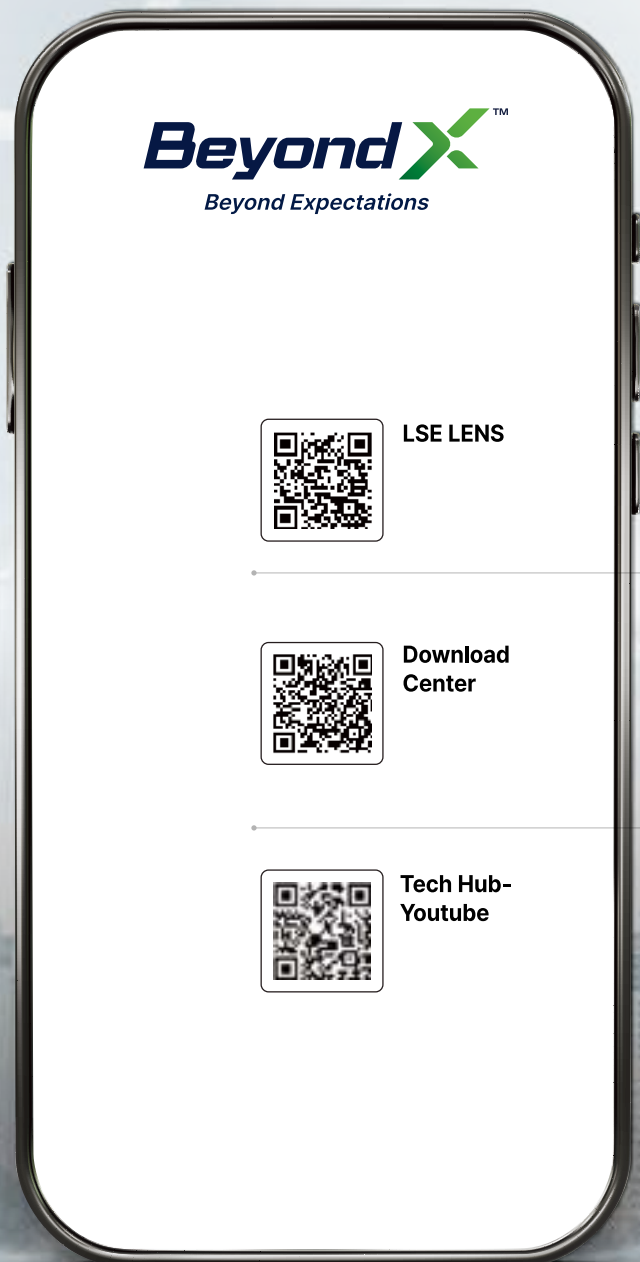



**One Scan,  
More Materials**

Scan the QR code to instantly  
access product materials



**Download with  
Ease and Speed**

Instantly access datasheets,  
manuals, and CAD files



**Expert Guidance,  
Now on YouTube**

Watch trusted tutorials and  
product guides from real experts





## Headquarter

127 LS-ro (Hogye-dong) Dongan-gu, Anyang-si, Gyeonggi-Do, 14119, Korea

## Seoul Office

LS Yongsan Tower, 92, Hangang-daero, Yongsan-gu, Seoul, 04386, Korea  
TEL: 82-2-2034-4916, 4684, 4429

## China

LS ELECTRIC (Dalian) Co., Ltd.  
+86-411-8730-5872  
china.dalian@lselectric.com.cn

LS ELECTRIC (Wuxi) Co., Ltd.  
+86-510-6851-6666  
china.wuxi@lselectric.com.cn

LS ELECTRIC (Lishui) Co., Ltd.  
+86-578-6866-780  
china.lishui@lselectric.com.cn

## Shanghai Office

+86-21-5237-9977  
china@lselectric.com.cn

## Beijing Office

+86-10-5095-1631  
china@lselectric.com.cn

## Guangzhou Office

+86-20-3818-2883  
china@lselectric.com.cn

## Qingdao Office

+86-532-8501-2065  
china@lselectric.com.cn

## Chengdu Office

+86-28-8670-3201  
china@lselectric.com.cn

## Nanjing Office

+86-25-84 67-0005  
china@lselectric.com.cn

## India

India Office  
+91-80-6142-9108  
Info\_india@ls-electric.com

## Indonesia

PT. LS ELECTRIC INDONESIA  
+62-21-2933-7614  
indonesia@ls-electric.com  
PT SYMPHOS ELECTRIC  
+62-81-1900-1474  
marketing@symphos-weltraf.com

## Italy

Italy office  
+39-030-8081-833  
italia@ls-electric.com

## Japan

LS ELECTRIC Japan Co., Ltd.  
+81-3-6268-8241  
japan@ls-electric.com  
Tokyo Office  
+81-3-6268-8241  
tokyo@ls-electric.com

## Netherlands

LS ELECTRIC Europe B.V.  
+31-20-654-1424  
europartner@ls-electric.com

## Russia

Moscow Office  
+7-499-682-6130  
info@lselectric-ru.com

## Singapore

Singapore Office  
+65-6958-8162  
singapore@ls-electric.com

## Spain

LS ELECTRIC IBERIA S.L.U.  
+34-910-28-02-74  
iberia@ls-electric.com

## Thailand

Bangkok Office  
+66-2-128-0295  
thailand@ls-electric.com

## Türkiye

LS ELECTRIC Türkiye Co., Ltd.  
+90-212-806-1252  
turkiye@ls-electric.com

## U.A.E

LS ELECTRIC Middle East FZE (Dubai)  
+971-4-886-5360  
middleeast@ls-electric.com

## USA

LS ELECTRIC America Inc.  
+1-800-891-2941  
sales.us@lselectricamerica.com

LS ENERGY SOLUTIONS LLC  
+1-980-221-0654  
info@ls-es.com

MCM Engineering II  
+1-435-865-0125  
sales.us@lselectricamerica.com

America Western Office  
+1-949-333-3140  
america@ls-electric.com

America Bastrop Campus  
+1-800-891-2941 EXT 2  
power\_support.us@lselectricamerica.com

## Vietnam

LS ELECTRIC Vietnam Co., Ltd.  
+84-222-2221-110  
vietnam@ls-electric.com

Hanoi Office  
+84-24-6275-8054  
vietnam@ls-electric.com

Ho Chi Minh Office  
+84-3823-7890  
vietnam@ls-electric.com

Specifications in this catalog are subject to change without notice due to continuous product development and improvement

© 2024. 04 LS ELECTRIC Co., Ltd. All rights reserved. / English (03) 2026. 01 Human Power

[www.ls-electric.com](http://www.ls-electric.com)

Distributed by Gross Automation | +1 (262) 252-1600 | [sales@grossautomation.com](mailto:sales@grossautomation.com)