

Beyond X™

Susol
UL LV Switchgear



LS ELECTRIC



Susol UL low voltage switchgear is designed to provide superior electrical distribution and protection for the facility. It is designed, built and tested to meet UL/ANSI standards and can be applied to a wide range of markets requiring high reliability and safety.

Susol UL low voltage switchgear is designed to safely contain and redirect arc flash energy away from the operator. LS's arc-resistant low voltage switchgear has been tested in all three compartments for a full 0.5 seconds (30 cycles), passing the ANSI/IEEE C37.20.7, Type 2B test guide at 100kA at 635V.

Contents

1. Overview	04
2. Product description	06
3. Technical data	12
4. Structure	14
5. Susol ACB (Power circuit breaker)	15
6. Layouts and dimensions	26
7. Partnership	30

Overview

High reliability & safety



- High reliability for all applications
 - All essential protection and safety functions guaranteed
 - Compliance with UL/ANSI standards (UL 1558, ANSI C37.20.1, ANSI C37.51, ANSI C37.20.7)
- Arc-resistant structure designed to protect personnel and property in the working environment
 - Arc fault containment: up to 100kAIR at 635Vac
- Seismic qualification
 - IEEE 693 High level 2.5g (Special seismic certification valid up to 3.0g)
 - ICC ES AC 156 1.3g (Special seismic certification valid up to 2.0g)
- ANSI Type 2B accessibility
- NEMA 1 enclosure

Convenience & high performance



- Modular design
 - Simplified and easily stackable structure for quick assembly
 - Reduction of lead time and rationalization of installation cost
 - Flexible arrangements and easy modifications
- Continuity of service and durability guaranteed
- Short circuit withstand rating up to 100kA/1s at 635Vac
- Up to 6,000A continuous current for both main and vertical bus
- Adopted and tested with LS ELECTRIC low voltage devices for accurate and optimum operation
- Exclusive insulator designed for LS ELECTRIC switchgear
- Optimized dimensions for footprint reduction
 - Width: 19.68”(D-type), 21.65”(E-type), 43.3”(G-type)

Expertise



- LS guarantees the quality and technical excellence based on expertise and lengthy experience in the design and manufacture of electrical devices and switchgears
- LS responds rapidly to the requirements of our customers and provides competitive design and solutions for each project through close cooperation

Applications



- | | | |
|-------------------------|--|---|
| Building | <ul style="list-style-type: none"> • Data center • Hospital • University | <ul style="list-style-type: none"> • Large office building • Large warehouse |
| Industry | <ul style="list-style-type: none"> • Oil and gas • Petroleum • Chemical • Iron and steel • Automobile | <ul style="list-style-type: none"> • Semiconductor • Mining and metal • Manufacturing • Food and beverage • Pharmaceutical |
| Utility / Public | <ul style="list-style-type: none"> • Power plants • Wastewater and water treatment • Airport | |

Product description

Key features

Arc resistant structure ready for type 2B class

The arc pressure relief vent at the top of the panel automatically opens when abnormal pressure is generated inside the section, helping to naturally reduce internal pressure. Although each compartment has a barrier, ventilation holes allow the relief vent to operate regardless of the arc fault location. The switchgear is engineered to meet ANSI Type 2B arc-resistant structure requirements. Even if the instrument compartment door adjacent to the arc fault is open, the exterior remains unaffected (note: this does not imply the instrument compartment door can be opened under actual operating conditions). The front vent is louvered to minimize potential harm to personnel in the event of an arc fault.

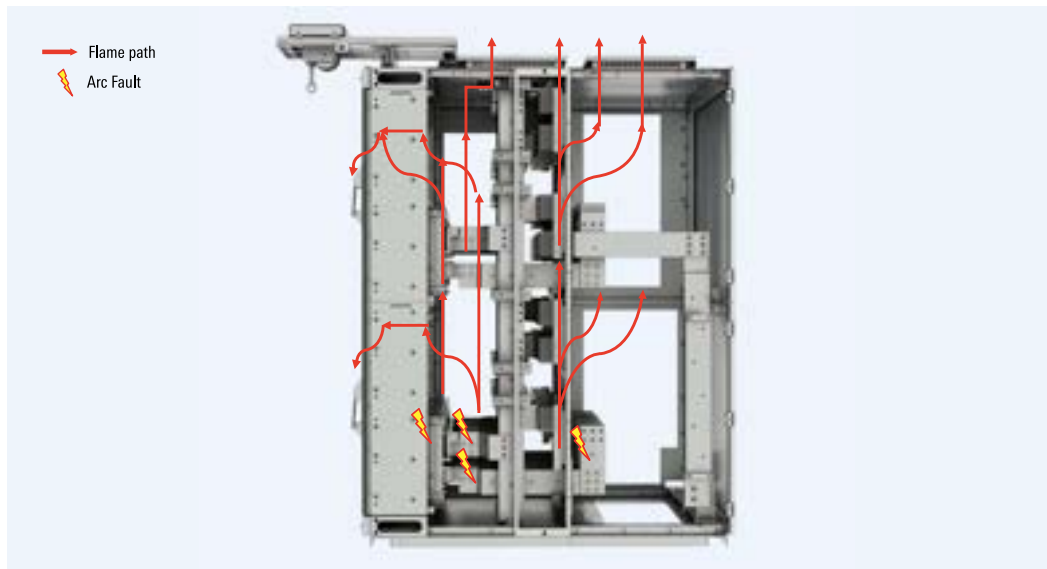

Modular design

Modular frame design makes it possible to have flexibility in the arrangements. Susol UL LV switchgear is divided into three modules - front, middle and rear module. Front module includes power circuit breaker, and it is designed as an enclosure type. Enclosure system leads in empowering on time delivery, lead time reduction and simplification. Maximum 4 stacks of CB compartment are available in a section. Front module can be assembled using only a door accessory kit and a power circuit breaker cradle composing CB compartment. Customers can select and compose devices for each panel to maximize efficiency. Only 1 module can be ordered and it is also possible to order the components in assembled form.

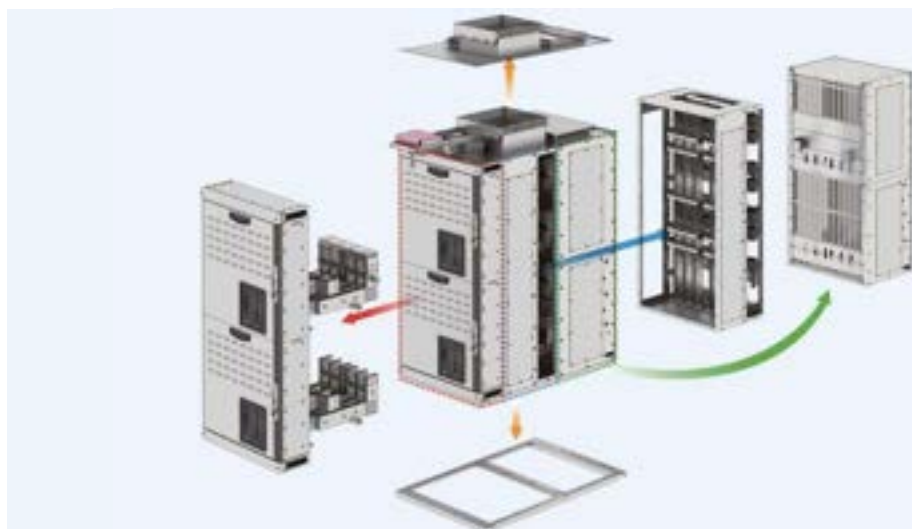

LS low voltage devices inside

LS circuit breakers are designed for precise coordination, isolating only the source of abnormal power. They offer long and reliable service life and are tested for short-circuit withstand capability. A variety of accessories are available for these breakers.

- Rated voltage: up to 635Vac
- Rated current: up to 6000A



Exclusive insulator for switchgear

All insulators used in busbar bracing structures are molded LS-only products, with LS guaranteeing insulation material performance. Designed to maintain all insulation distances in accordance with ANSI C37.20.1, they provide excellent product safety.

The use of standardized products minimizes human error and enables easy assembly. A part list is provided to facilitate section assembly and reduce material waste. All assembly materials are UL-listed.



Standards

Susol UL low voltage switchgear conforms to the following standards:

- UL 1558
- ANSI C37.20.1
- ANSI C37.51
- ANSI C37.20.7

Susol low-voltage power circuit breaker conforms to the following standards:

- ANSI C37.13, ANSI C37.16, ANSI C37.17, ANSI C37.50
- UL 1066 (cULus Listed)
- CSA C22.2 No.31-10



CB compartment 1-module



CB compartment ass'y

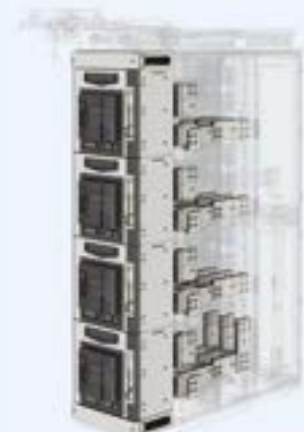

CB compartment in a section
(Maximum 4 stack available)

Product description

Structure features

Separated compartments

Each compartment is divided by metal partitions. CB compartment is designed as full metal enclosure in accordance with UL/ANSI standards. Thickness of sheet-metal that separates each compartment is more than 3.0mm. Bus compartment and cable compartment are separated by sheet-metal barrier and insulated plate partition for preventing arc fault from spreading and for maintaining availability of a power supply. Barriers between sections also can be provided if required. Safer, easier, and faster maintenance is possible.

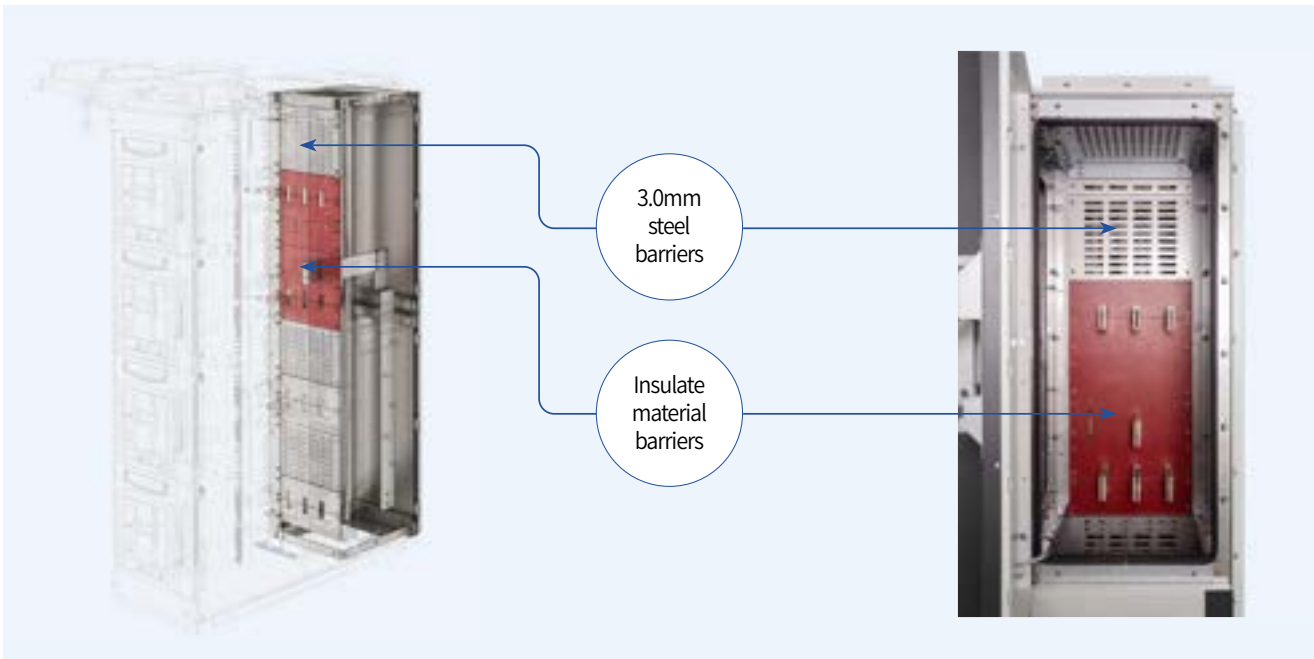

Through-the-door design

The following functions can be performed without opening the compartment door - push on/off button of ACB, control the manual charging lever, withdraw and insert the ACB. The door can be completely opened when the ACB is under disconnected position.

Drawable design

A cradle is provided in the circuit breaker cell, with extendable rails to facilitate breaker insertion and withdrawal, allowing easy movement to the service position with minimal effort.

4-position draw-out design

Breakers can be positioned in service, test, disconnected, or withdrawn modes. Movement between service, test, and disconnected positions is controlled via a handle in the cradle, with a padlock provided at each position for user safety.

Interlocks

Interlocks are provided between breakers and between the device and the door.

Paint

The standard color is gray (ANSI 61), with other color options available upon request.

Optional safety shutters [ST]

The automatic safety device protects the main circuit connectors by preventing hazardous external contact when the breaker is withdrawn. The shutter automatically opens when the ACB is inserted.



Through-the-door design



Cradle in the breaker cell

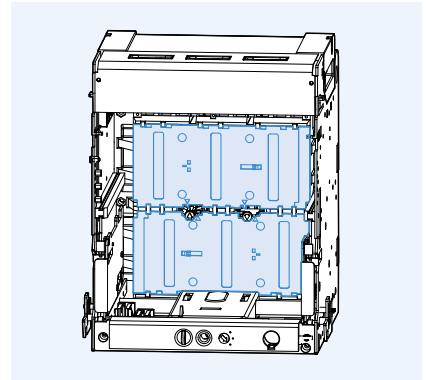

Safety shutter

User-friendly design

Hinged doors that open more than 90° provide ample space for operation and maintenance. Switchgear can be installed regardless of side wall orientation, thanks to reversible LHS and RHS hinged doors. Doors of each compartment can be opened and closed individually, with robust handles and door locks ensuring high reliability.

Wireways exceeding 100 mm at the top and bottom of each panel facilitate convenient wiring between devices, instruments, and lamps, while enabling efficient control wire organization.



Product description

Bus features

Busbar design

The temperature rise performance of busbars meets the requirements of ANSI C37.20.1, C37.51 and all the busbars are silver plated. M12(8.8) high strength bolt is applied for both vertical and main bus, and spring washer and plain washer are applied. The minimum distance for air clearance is 1". For creepage distance, the minimum distance between phases is 2", and between phase and earth is 1". The thickness of busbar is 1/4", and the width can be 3", 4", 5" or 6" depending on capacity. All the connection point is bolted joint.

Main and ground bus bracing

All bus designs comply with UL and ANSI standards for a 65K temperature rise at 40°C ambient temperature.

Main bus ratings are 2000, 2500, 3200, 4000, 5000 and 6000A with bus bracing of 100kA/1s bus bracing for all types. (Contact us for higher specifications.)

Vertical bus ratings include 800, 1000, 1200, 2000, 2500, 3200, 4000, 4500, 4755, 5000, and 6000A, with bus bracing as follows: 65kA/1s for D-type, 85kA/1s for E-type, and 100kA/1s for G-type. (Contact us for higher specifications.)

Neutral bus is rated at 100% of the main bus, with bracing identical to the main bus. Ground busbars have a cross-sectional area of 1/4" x 4", a peak withstand current of 230kA, and an RMS current rating of 100kA/0.5s.



Options

Optional overhead hoist

It is possible to provide an overhead hoist that can move along the rail installed on the upper part of the panel. Since it can be moved by rail without installing 1EA per section, 1 set per room can be installed for efficient operation. In addition, the maximum load is 300kgf, which is enough to carry even the heaviest models of ACB.



Over head hoist unit

Hoist mounted on switchgear

Connection for moving to assemble

Optional Motorized Control Racking System [MCRS]

Motorized control racking enhances operator safety by increasing the distance from potential arc flash energy at the switchgear.

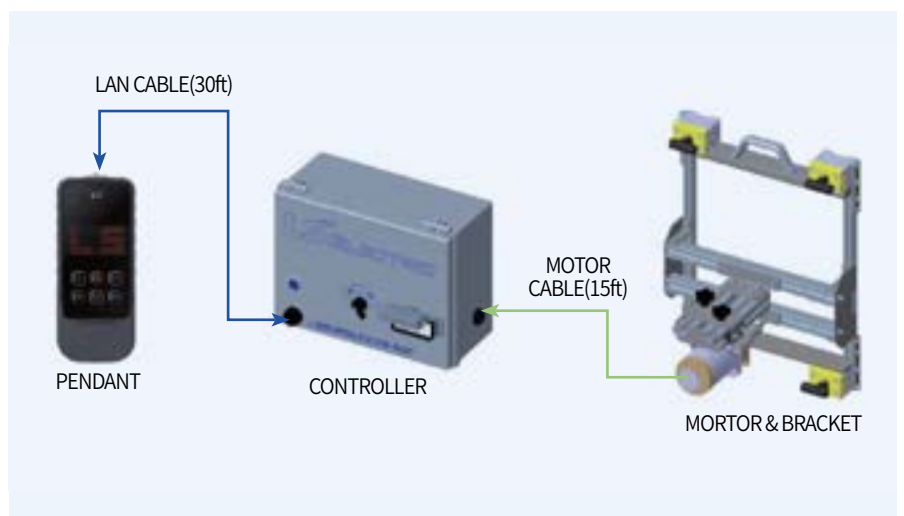

MCRS [External Motor Type]

Technical data

Designation

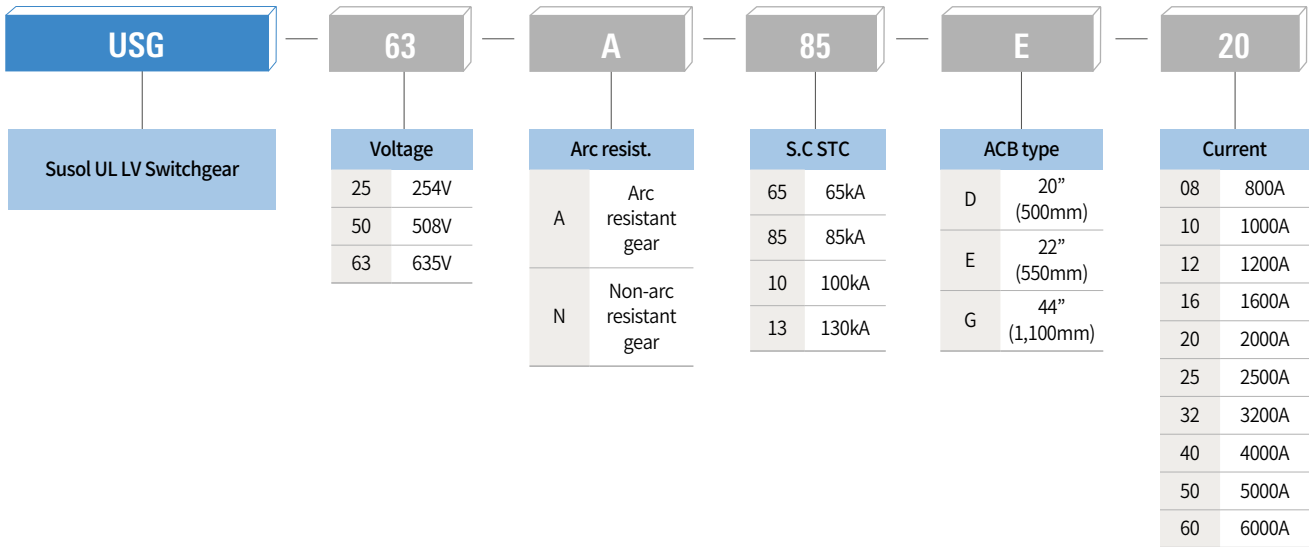

- Susol Low Voltage Switchgear for the Americas can be ordered using the model names above.
- Rated voltage ranges from 254 V to 635 V, with enclosures classified as internal arc or non-arc type according to protection level.
- Busbar bracing allows selection from 65 kA to 130 kA, with enclosure sizes of 20", 22", and 44" available for each ACB type. (Contact us for 130 kA.)
- The last two digits of the model can be selected to indicate the representative rating of the switchgear, depending on main bus capacity.

Ratings

Description			USG-□□D (D-type)	USG-□□E (E-type)	USG-□□G (G-type)
Type					
Rated voltage	V, rms		Up to 635 V		
Rated short circuit withstand current	H-BUS	kA, rms	100(@635V)	100(@635V)	100(@635V)
	V-BUS		65(@635V)	85(@635V)	100(@635V)
Duration time	sec		1	1	1
Stack			4 high		2 high
Rated current	A, rms		800, 1000, 1200, 1600	800, 1000, 1200, 1600, 2000, 2500/3200	3200, 4000, 5000, 6000
Frequency	Hz		60		
Insulation level	Power frequency	kV, rms	2.2		
Enclosure protection			NEMA 1		
Standard size	W	Inch (mm)	19.68 <i>Note 1</i> (500)	21.65 <i>Note 1</i> (550)	43.3 (1100)
	H	Inch (mm)	91.73 (2330)		
	D	Inch (mm)	62 <i>Note 2</i> (1575)		71.85 <i>Note 2</i> (1825)
Internal arc rating (ANSI TYPE 2B)			-		100kA, 0.5s, 635V
Standards			UL 1558, ANSI C37.20.1, ANSI C37.51, ANSI C37.20.7		

Note 1. The width in the ratings table is the minimum size. Depending on the specifications of devices such as lamps, relays, and TTM (Test terminals) installed on the front door, the width can be extended up to a maximum of 31.5 inches (800 mm).

Note 2. The depth in the ratings table is the minimum size. Depending on specifications such as the number of cables per circuit breaker and the need for additional space for rear cable connections, the depth can be extended up to a maximum of 102.36 inches (2600 mm).

Structure

Structure

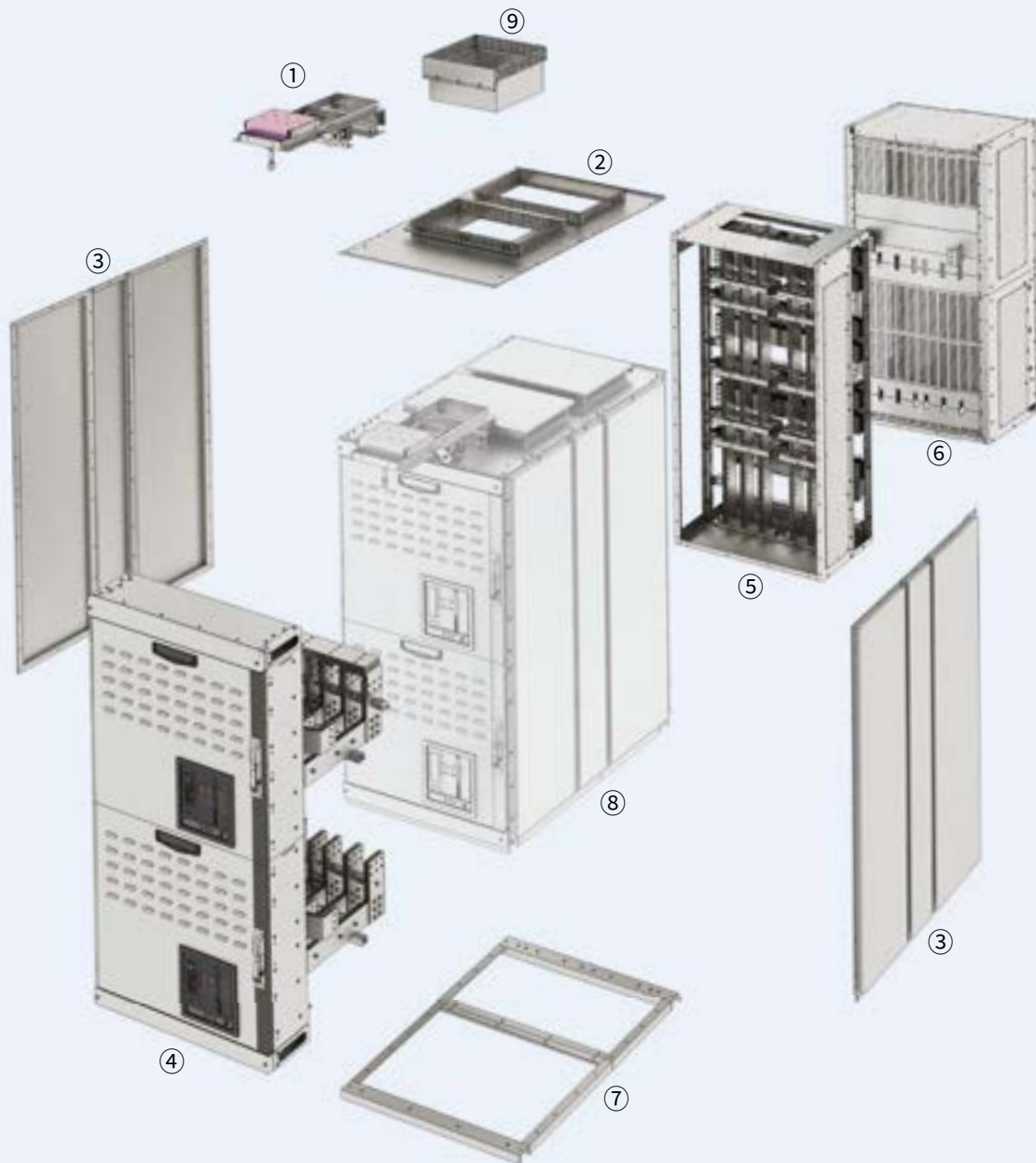

- ① Over head ACB lifter
- ② Top cover ass'y (Ventilation module/ Arc relief cover)
- ③ Side cover plate (3 pieces)
- ④ Front module ass'y (CB comp. module & Cable race way)
- ⑤ Middle module ass'y (Bus comp. module, 6000A)

- ⑥ Rear module ass'y (Cable comp., Ground busbar)
- ⑦ Channel base ass'y (W 1,100)
- ⑧ G-type 6000A total ass'y
- ⑨ Optional fan

Susol UL listed/ANSI certified low-voltage power circuit breaker

Premium Susol ACB meets your demands for high breaking capacity with full line-up up to 6000A, all in optimized frame sizes for panel design. Various accessories and connection methods realize user-friendly handling. Susol ACB provides the total solution with an advanced trip relay for measurement, diagnosis, analysis, and communication as well as protective functions for absolute protective coordination and electric power monitoring system.

- Susol ACB low voltage power circuit breakers are designed and built to the following standards.
 - ANSI C37.13, ANSI C37.16, ANSI C37.17, ANSI C37.50, UL 1066 (cULus Listed), CSA C22.2 No.31-10
- Modular design
- 3 compact frame sizes that enables users to design panels of optimal volume
- High (130kA) breaking capacity full line-up to 6000A at 508Vac
- Satisfy the needs for compact sized panels
- N-Phase conducting capacity 100%
- Monitor temperatures for safety (Optional)
- Easy installation of accessories
- Interchangeable trip unit and rating plug
- Intelligent trip relay with various advanced functions for protection, measurement, diagnosis, analysis and communication



Susol ACB (Power circuit breaker)



Ratings

		Type		
		AF		
Rated current (CT Ratio)	(A)		at 40°C	
Rated current (Available rating plug)	(V)		at 40°C	
Rated maximum voltage	(V)			
Frequency	(Hz)			
Number of poles	(P)			
Type of trip relay (Electronic trip device)				
Rated short circuit current (Sym.) (Duty: O-15s-CO)	(kA)	With instantaneous	AC	847V(60Hz)
				635V
		Without instantaneous	AC	847V(60Hz)
				635V
Rated making current (X/R=more than 6.6)	(kA peak)	With instantaneous	AC	847V(60Hz)
				635V
		Without instantaneous	AC	847V(60Hz)
				635V
Rated short time current	(kA)		AC	847V(60Hz)
				635V
				508V
				254V
Operating time (t)	(ms)			Breaking time
				Opening time
				Closing time
				Charging time
Endurance rating C/O Cycles (Without maintenance)	(Cycles)	Mechanical (60 times per hour)		
		Electrical (30 times per hour)		
Weight (Include charging motor)	lb (kg)	Drawout type	Main Body	3P
			with Cradle	4P
			Only Cradle	3P
		Fixed type	4P	
			3P	
			4P	
External dimension	Draw-out type	in (mm)	H×W×D	3P
				4P
				Fixed type
	Fixed type	in (mm)	H×W×D	3P
				4P
				Enclosure dimension
Enclosure dimension	in (mm)	H×W×D	3P	
			4P	
Operation temperature				-13°F ~ 140°F (-25°C ~ 60°C)
Certified standards				UL 1066 / ANSI C37.13

Susol	
UAS-□□D	
08	16
800	1600
400	800
600	1000
630	1200
800	1250
	1600
254V / 508V / 635V	
UAS: 50/60	
3P / 4P	
N, A, P, S (4 type)	
	-
	65
	85
	85
	-
	65
	65
	65
	65
	-
	149.5
	195.5
	195.5
	-
	149.5
	150.5
	151.5
	60
	Less than 30ms
	Less than 50ms
	Less than 80ms
	Less than 5 sec.
	12,500
	2,800
	154 (70)
	187 (85)
	71 (32)
	84 (38)
	77 (35)
	99 (45)
	16.93×13.15×16.02
	(430×334×407)
	16.93×16.50×16.02
	(430×419×407)
	11.81×11.81×11.61
	(300×300×295)
	11.81×15.16×11.61
	(300×385×295)
	19.69×15.75×13.39
	(500×400×340)
	19.69×19.69×13.39
	(500×500×340)
	-13°F ~ 140°F (-25°C ~ 60°C)
	UL 1066 / ANSI C37.13



Susol				
UAH-□□E / UAW-□□E				
08	16	20	25	32
800	1600	2000	2500	3200
400	800	1000	1200	1600
600	1000	1200	1250	2000
630	1200	1250	1600	2500
800	1250	1600	2000	3000
	1600	2000	2500	3200
254V / 508V / 635V / 847V(UAW)				
UAH/UAW: 50/60				
3P / 4P				
N, A, P, S (4 type)				
85				
85				
100				
100				
85				
85				
85				
85				
195.5				
195.5				
230				
230				
195.5				
195.5				
195.5				
195.5				
85				
Less than 30ms				
Less than 50ms				
Less than 80ms				
Less than 5 sec.				
12,500			5,000	
2,800			1,000	
214 (97)		245 (111)		326 (148)
269 (122)		309 (140)		414 (188)
99 (45)		123 (56)		205 (93)
121 (55)		152 (69)		256 (116)
101 (46)		110 (50)		196 (89)
126 (57)		137 (62)		249 (113)
16.93×16.22×16.02 (430×412×407)				
16.93×20.75×16.02 (430×527×407)				
11.81×14.88×11.61 (300×378×295)				
11.81×19.41×11.61 (300×493×295)				
19.69×19.69×13.39 (500×500×340)				
19.69×24.21×13.39 (500×615×340)				
-13°F ~ 140°F (-25°C ~ 60°C)				
UL 1066 / ANSI C37.13				

Susol			
UAH-□□G			
32	40	50	60
3200	4000	5000	6000
1600	2000	2500	3000
2000	2500	3000	3200
2500	3000	3200	3600
3000	3200	3600	4000
3200	3600	4000	5000
	4000	5000	6000
254V / 508V / 635V			
UAH: 50/60			
3P / 4P			
N, A, P, S (4 type)			
-			
100			
130			
130			
-			
100			
100			
100			
-			
230			
299			
299			
-			
230			
230			
230			
100			
Less than 30ms			
Less than 50ms			
Less than 90ms			
Less than 5 sec.			
5,000			
1,000			
489 (222)			
626 (284)			
276 (125)			
355 (161)			
227 (127)			
287 (130)			
18.11×30.91×16.02 (460×785×407)			
18.11×39.96×16.02 (460×1015×407)			
11.81×29.57×11.61 (300×751×295)			
11.81×38.62×11.61 (300×981×295)			
31.50×32.48×13.39 (800×825×340)			
31.50×41.54×13.39 (800×1055×340)			
-13°F ~ 140°F (-25°C ~ 60°C)			
UL 1066 / ANSI C37.13			

Susol ACB (Power circuit breaker)

Trip relay (OCR)

The trip relay of Susol ACB provides the additional protection functions for voltage, frequency, unbalance, and others in addition to main protection functions for over current, short-circuit, ground fault. It supports the advanced measurement functions for voltage, current, power, electric energy, harmonics, communication function, and others. Analog trip function interlocked with mechanism enhances the durability as well as the breaking capacity of the ACB. Zone selective interlocking function makes the protective coordination more simple and thermal memory can be applied to various loads.

Trip relays are classified according to function.

Trip relays are classified according to their uses and functions to maximize customers' satisfaction. They are also easy to installation for customers' convenience.

- Protection : overload, short current, ground fault, earth leakage, under voltage, over voltage, under frequency, over frequency, reverse power, unbalance, etc.
- Measurement: voltage, ampere, power, energy, frequency, power factor, harmonics, etc.
- Event & fault recording: Max. 256 events & faults.
- Communication: Modbus/RS-485, Profibus-DP.



Trip relay types

		N-Type	A-Type	P-Type	S-Type
Externals					
Current relay		• L, S, I, G	• L(N), S, I, G, PTA, Gext	• L(N), S1, I, G, PTA, Gext • D, S(V)1, IU	• P type Current relay • S(V)2
Voltage relay		-	-	• UV1, OV1, RV, VU	• P type Voltage relay • UV2, OV2
Frequency relay		-	-	• UF1, OF1, ROCOF	• P type Frequency relay • UF2, OF2
Power relay		-	-	• RP, RQ1, OP, OQ, UP	• P type Power relay • RP, RQ1, RQ2
Group control		-	-	-	• A,B (Control by DI and communication)
Relay fine tuning		-	-	• Possible (Adjust knob and freely set operating value current)	• Possible (Freely set operating value current)
ERMS		-	• Control by DI and Communication	• Control by DI and Communication	• Control by DI and Communication
IDMTL Support		-	• L relay element (Thermal, DT, SIT, VIT, EIT, EIT50)	• L relay element (Thermal, DT, SIT, VIT, EIT, EIT50)	• L relay element (Thermal,DT,SIT,VIT, EIT,EIT50)
Trip information Maintenance LED		• L, S, I, G • SP : Self protection	• L, S, I, G/Gext/PTA, SP	• L, S, I, G/Gext/PTA, SP	• L, S, I, G/Gext/PTA, SP
Incident record	Screen	-	• Display of 32 incident events (Incident phase/current/time)	• Display of 127 incident events (Incident phase/current/time)	• Display of 127 incident events (Incident phase/current/time)
	Memory	-	• Saves 127 incident events • Saves 6 incident waveforms (In case of operation by Self Power, incident waveform is not saved)	• Saves 127 incident events • Saves 6 incident waveforms (In case of operation by Self Power, incident waveform is not saved)	• Saves 127 incident events • Saves 6 incident waveforms (In case of operation by Self Power, incident waveform is not saved)

Susol ACB (Power circuit breaker)

Trip relay (OCR)

	N-Type	A-Type	P-Type	S-Type
Measuring function	<ul style="list-style-type: none"> • Current [R/S/T/N] 	<ul style="list-style-type: none"> • Current [R/S/T/N] • External CT current • Current phase (Based on the phase A) • Vector Sum zero sequence current • Imbalance negative sequence current • Previous current demand for each phase 	<ul style="list-style-type: none"> • 3 phase voltage, line - to - line voltage • Current (R/S/T/N) • Vector Sum zero sequence Current • 3 phase voltage, line - to - line voltage • Frequency • External CT current • Voltage/Current phase (Based on the phase A) • Total/Each phase power (P, Q, S) • Total/Each phase power factor • Positive/Negative, Effective/Reactive/Apparent energy • Vector sum zero sequence voltage • Vector sum zero sequence current • Positive, Negative sequence voltage • Positive, Negative sequence current • Voltage imbalance rate • Current imbalance rate • Previous current demand for each phase • Previous apparent, reactive and active power demand 	<ul style="list-style-type: none"> 3 phase voltage, line - to - line voltage • Current (R/S/T/N) • Vector Sum zero sequence Current • 3 phase voltage, line - to - line voltage • Frequency • External CT current • Voltage/Current phase (Based on the phase A) • Total/Each phase power (P, Q, S) • Total/Each phase power factor • Positive/Negative, Effective/Reactive/Apparent energy • Vector sum zero sequence voltage • Vector sum zero sequence current • Positive, Negative sequence voltage • Positive, Negative sequence current • Voltage imbalance rate • Current imbalance rate • Previous current demand for each phase • Previous apparent, reactive and active power demand
Accuracy degree of measurement	Current	• 0.5%	• 0.5%	• 0.5%
	Voltage	-	-	• 0.5%
	Power	-	-	• Class 1 (IEC 62053 - 21, 22)
	Frequency	• 50Hz or 60Hz	• 50Hz or 60Hz	• 0.1% (10 ~ 200Hz)
PQ function	-	<ul style="list-style-type: none"> • Voltage/Current harmonics harmonics 63rd • Current THD, TDD, K – Factor 	<ul style="list-style-type: none"> • Voltage/Current harmonics harmonics 63rd • Voltage THD • Current THD, TDD, K – Factor 	<ul style="list-style-type: none"> • Voltage/Current harmonics harmonics 63rd • Voltage THD • Current THD, TDD, K – Factor
Measurement record	-	<ul style="list-style-type: none"> • Max Ext Io • Max Current demand • Max Io • Max In • Max Max internal temperature 	<ul style="list-style-type: none"> • Max Current demand • Demand for max apparent, reactive and active power • Max active power • Max Vo • Max Io • Max Ext Io • Max In • Max internal temperature 	<ul style="list-style-type: none"> • Max Current demand • Demand for max apparent, reactive and active power • Max active power • Max Vo • Max Io • Max Ext Io • Max In • Max internal temperature
Real time waveform	• Using USB communication	• Using USB/RS485 communication	• Using USB/RS485 communication • Using LCD screen	• Using USB/RS485 communication • Using LCD screen

* N type can check measurement function, measurement record, and PQ function through USB communication.

	N-Type	A-Type	P-Type	S-Type
Communication	<ul style="list-style-type: none"> • USB (For site operator) • NFC (Near Field communication) 	<ul style="list-style-type: none"> • USB (For site operator) • RS485/Modbus (Communication type Only) 	<ul style="list-style-type: none"> • USB (For site operator) • RS485/Modbus • BLE (Bluetooth, Option) 	<ul style="list-style-type: none"> • USB (For site operator) • RS485/Modbus • BLE (Bluetooth) • NFC (Near Field communication)
Power	<ul style="list-style-type: none"> • Self Power (Operates when it is higher than 30% of rated current by single phase load) 	<ul style="list-style-type: none"> • Self Power (Operates when it is higher than 30% of rated current by single phase load) • AC/DC 88~264V • DC 24V/48V 	<ul style="list-style-type: none"> • Self Power (Operates when it is higher than 50% of rated current by single phase load) • AC/DC 88~264V 	<ul style="list-style-type: none"> • Self Power (Operates when it is higher than 50% of rated current by single phase load) • AC/DC 88~264V
Event record	-	<ul style="list-style-type: none"> • 255 kinds including change of device status (Information, status, date and time) 	<ul style="list-style-type: none"> • 255 kinds including change of device status (Information, status, date and time) 	<ul style="list-style-type: none"> • 255 kinds including change of device status (Information, status, date and time)
Clock	-	<ul style="list-style-type: none"> • RTC embedded (Back up with battery) 	<ul style="list-style-type: none"> • RTC embedded (Back up with battery) 	<ul style="list-style-type: none"> • RTC embedded (Back up with battery)
Other LED	<ul style="list-style-type: none"> • Run, Alarm, Self diagnosis 	<ul style="list-style-type: none"> • Run, Alarm, Self diagnosis, Communication 	<ul style="list-style-type: none"> • Run, Alarm, Self diagnosis, Communication 	<ul style="list-style-type: none"> • Run, Alarm, Self diagnosis, Communication
Operating button	<ul style="list-style-type: none"> • Reset button 	<ul style="list-style-type: none"> • Reset/Menu/Tap/Up, Down/Enter 	<ul style="list-style-type: none"> • Reset button • LCD Touch 	<ul style="list-style-type: none"> • Reset button • LCD Touch
Self diagnosis	LED	<ul style="list-style-type: none"> • RUN/AL LED blinking (Red ↔ Blue blinking) 	-	<ul style="list-style-type: none"> • RUN/AL LED blinking (Red ↔ Blue blinking)
	LCD	-	<ul style="list-style-type: none"> • Displays relevant Segment or error number at LCD 	<ul style="list-style-type: none"> • Can check at self diagnosis screen on LCD
	List	<ul style="list-style-type: none"> • Battery Low Alarm: Occurs when internal battery is not inserted or battery voltage is low. • Rating Plug Unmatched or Error: Rating Plug is not assembled or there's an error with Rating Plug. • Ampere Frame Error: Value of Rating Plug is not within 45 ~ 100% of AF. • MTD Fail (Wiring check): STU is not assembled with MTD or Trip coil is disconnected. • Factory Cfg Error: Factory mode setting is wrong. • Device Type Error: Rating Plug information is different from CT information. • Over Heat Error: Internal temperature of CPU is over 100 degree (N/A type) or 115 degree (P/S type) • Contact Wear Alarm: Contact wear rate is over 80% • Electrical Open Count Over Alarm: Electrical Open Count is over the tolerable degree of 80%. • Mechanical Open Count Over Alarm: Mechanical Open Count is over the tolerable degree of 80% • RTC Error: There is an error in the internal RTC information. • Memory Error: Duplicated internal setting saved at internal nonvolatile memory was damaged. • CT disconnection Error: CT disconnection occurred (Each phase is monitored). • ROM Err: Occurs when there is a problem with the software ROM • RAM Err: Occurs when there is a problem with the software RAM • CLOCK Err: Occurs when there is a problem with the software clock • PROGRAM Cnt. Err: Occurs when there is a problem with the software program counter • CPU Reg. Err: Occurs when there is a problem with the software CPU Register 		

* N type can check the event records through USB communication

Susol ACB (Power circuit breaker)

Ordering - Breaker and accessories

UAS	16	D	3	16	A
Frame type	Frame size	Phasing	Poles	Sensor rating	Mounting and terminal
	08 800AF 16 1600AF	D 3/4P standard RST(N) W 4P reversed NRST	3 3P 4 4P	04-08 400A~800A 08-16 800A~1600A	Mounting A Drawout Fixed
UAH	32	E	3	32	H Horizontal terminals V Vertical terminals M Horizontal for line Vertical for load N Vertical for line Horizontal for load P Front terminal G Horizontal-con type W Vertical-con type
Frame type	Frame size	Phasing	Poles	Sensor rating	
	08 800AF 16 1600AF 20 2000AF 25 2500AF 32 3200AF 32 3200AF 40 4000AF 50 5000AF 60 6000AF	E 3/4P standard RST(N) X 4P reversed NRST G 3/4P standard RST(N) Z 4P reversed NRST	3 3P 4 4P 3 3P 4 4P	04-08 400A~800A 08-16 800A~1600A 10-20 1000A~2000A 12-25 1200A~2500A 16-32 1600A~3200A 16-32 1600A~3200A 20-40 2000A~4000A 25-50 2500A~5000A 30-60 3000A~6000A	
UAW	32	E	3	32	
Frame type	Frame size	Phasing	Poles	Sensor rating	
	08 800AF 16 1600AF 20 2000AF 25 2500AF 32 3200AF	E 3/4P standard RST(N) X 4P reversed NRST	3 3P 4 4P	04-08 400A~800A 08-16 800A~1600A 10-20 1000A~2000A 12-25 1200A~2500A 16-32 1600A~3200A	
UAA	16	D	3	00	
Frame type	Frame size	Phasing	Poles	Sensor rating	
	08 800AF 16 1600AF 08 800AF 16 1600AF 20 2000AF 25 2500AF 32 3200AF 32 3200AF 40 4000AF 50 5000AF 60 6000AF	D 3/4P standard RST(N) W 4P reversed NRST E 3/4P standard RST(N) X 4P reversed NRST G 3/4P standard RST(N) Z 4P reversed NRST	3 3P 4 4P	Not applied	

* Terminals for P type must be ordered separately
 * G and W types are applicable to D-frame only
 * Front terminal is only available for 800-2000A
 * 3200AF(E, X), 6000AF(G,Z) offers only vertical type terminals (Busbar).
 * 6000AF is only available for drawout type

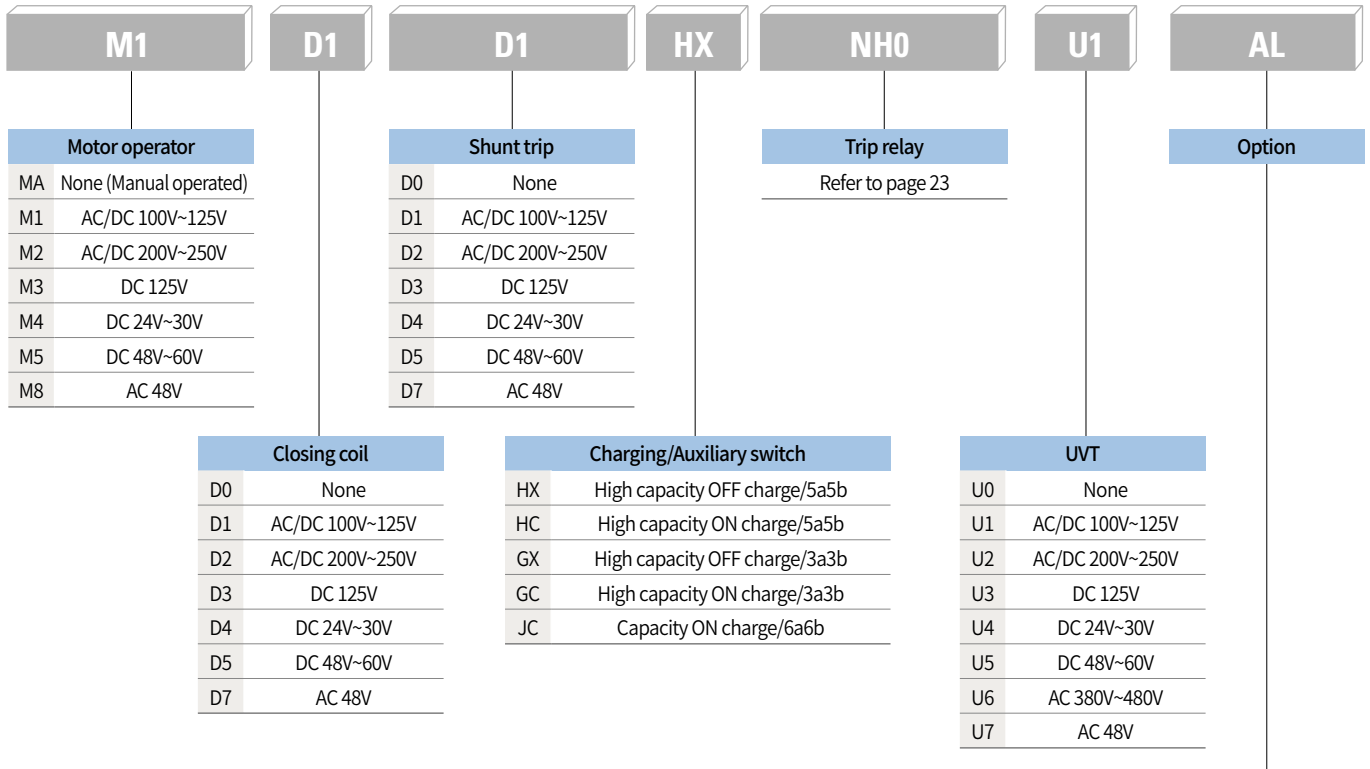

Code	Description	Code	Description
AL	AL1+MRB	K	K1 Key lock
A1	AL1+MRB+RES (AC110~130V) *AC only	K2	K2 Key Interlock set
A2	AL1+AL2+MRB	K3	K3 Key Interlock double
A3	AL1+MRB+RES (DC110~125V) *DC only	K4	K4 Key lock (Same key)
A4	AL1+MRB+RES (AC200~250V) *AC only	K5	K5 Note 4 Profalux lock (CAMLOCK type)
A5	AL1+MRB+Auto reset	K6	K6 Note 4 Kirkkey lock (CAMLOCK type)
A6	AL1+AL2+MRB+Auto reset	K7	K7 Note 4 Kirkkey lock (CN-22 type)
A7	AL1+MRB+RES (DC110~125V) +Auto reset *DC only	R	RCS Ready to close switch
A8	AL1+MRB+RES (AC200~250V) +Auto reset *AC only	T	TM Temperature monitoring
A9	AL1+MRB+RES (AC110~130V) +Auto reset *AC only	H1	H1 AC/DC 100V ~125V, Double shunt coil
S	CS2 Charge switch communication	H2	H2 AC/DC 200V ~250V, Double shunt coil
B	B Lockable On/Off button cover	H3	H3 DC 125V, Double shunt coil
M	MI Mechanical interlock	H4	H4 DC 24V ~30V, Double shunt coil
D	DI or MOC Door interlock or MOC (Mechanism operated cell switch)	H5	H5 DC 48V ~60V, Double shunt coil
(-)	Without VDM module (External type VDM is required to order)	H7	H7 AC 48V, Double shunt coil

N01	A4 (AL1+MRB+RES(AC200~250V))+B(Lockable On/Off button cover)+K(Key lock)+R(Ready to close switch)+M(Mechanic interlock)+E(Spring auto release)
N02	AL (AL1+MRB)+K(Key lock(OFF lock))+R(Ready to close switch)+D(Door interlock or MOC)+H1(AC/DC 100V ~ 130V, Double shunt coil)+E(Spring auto release)
N03	B(Lockable On/Off button cover)+K2(Key interlock set)+R(Ready to close switch)+T(Temperature monitoring)
N04	A4(AL1+MRB+RES(AC200~250V))+B(Lockable On/Off button cover)+K(Key lock(OFF lock))+M(Mechanical interlock)+T(Temperature monitoring)
N05	A1(AL1+MRB+RES110~130V)+B(Lockable On/Off button cover)+K(Key lock(OFF lock))+R(Ready to close switch)+M(Mechanical interlock)+T(Temperature monitoring)
N06	A2(AL1+AL2+MRB)+K(Key lock(OFF lock))+R(Ready to close switch)+T(Temperature monitoring)

Note) 1. * Codes for over 5 optional accessories are composed separately.
 2. UVT and SHT2 can not be selected together. Select one of two.
 3. C(counter) is provided as standard.
 4. K5, K6, K7 options are factory installed keylock.

Susol ACB (Power circuit breaker)

Ordering - Adapter (Cradle)

UAL

For UL ACB cradle type



S16D

Frame size <small>Note</small>	
S16D	1600AF
S20E	2000AF
S25E	2500AF
S32E	3200AF
S50G	5000AF
S60G	6000AF

3

Number of poles	
3	3P
4	4P

A

Secondary connector type	
A	Connector type
B	Screw joint type
C	Spring type

H

Terminal configuration	
H	Horizontal type
V	Vertical type
M	Line: Horizontal Load: Vertical
N	Line: Vertical Load: Horizontal
P	Front type
G	Horizontal-con type
W	Vertical-con type

E

Shutter	
E	Without safety shutter
F	With safety shutter

S

Other options	
N	ARC Cover N/A
S	Arc cover
ST	Arc Cover+Metering CT

Note) The corresponding Breaker Adapter

Breaker	Adapter	Breaker	Adapter
UAS-08D	UAS-08W	UAH-32E	UAH-32X
UAS-16D	UAS-16W		
UAH-08E	UAH-08X	UAH-40G	UAH-40Z
UAH-16E	UAH-16X		
UAH-20E	UAH-20X	UAH-60G	UAH-60Z
UAH-25E	UAH-25X		

- * Terminals for P type must be ordered separately
- * G and W types are applicable to S16D (1600AF) only
- * Metering CT for ST type must be ordered separately

* The depth of Metering CT included cradle is longer than normal cradle

Rating plug

Rating plug classification			ACB ampere frame								
Rating plug code	For none NCT type	For NCT type	Rating	800A	1600A	2000A	2500A	3200A	4000A	5000A	6000A
		73263466352	73263466372	400A	400A~800A						
	73263466353	73263466373	600A								
	73263466354	73263466374	630A								
	73263466355	73263466375	800A								
	73263466356	73263466376	1000A	800A~1600A							
	73263466357	73263466377	1200A								
	73263466358	73263466378	1250A								
	73263466359	73263466379	1600A								
	73263466360	73263466380	2000A	1000A~2000A							
	73263466361	73263466381	2500A								
	73263466362	73263466382	3000A								
	73263466363	73263466383	3200A								
	73263466364	73263466384	3600A	1200A~2500A							
	73263466365	73263466385	4000A								
	73263466366	73263466386	5000A								
	73263466367	73263466387	6000A								
				1600A~3200A							
				2000A~4000A							
				2500A~5000A							
				3000A~6000A							

* A rating plug ranging from 50 to 100% of the ACB ampere frame should be used.
 * The minimum value of the Trip Relay self-power supply is based on the CT rating, not the rating plug rating.

Ordering - Trip relay

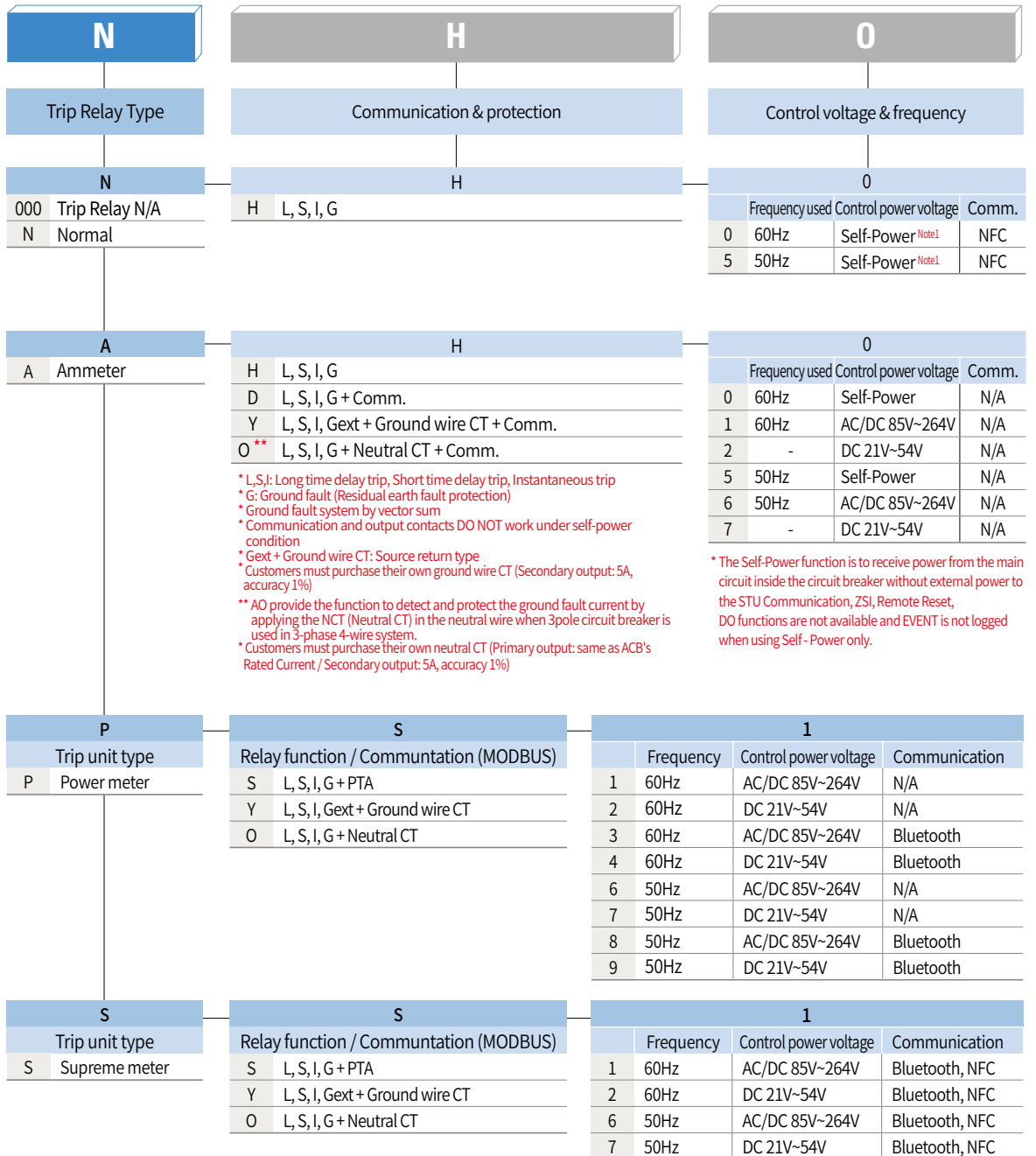

* Self-power is basic function (Automatic power supply to the trip unit without additional control power)
 * L,S,I: Long time delay trip, Short time delay trip, Instantaneous trip
 * G: Ground fault (Residual earth fault protection)
 * Gext + Ground wire CT: Source return type * PTA: Pre-trip alarm function
 * Customers must purchase their own ground wire CT (Secondary output: 5A, accuracy 1%)
 * Customers must purchase their own neutral CT (Primary output: same as ACB's Rated Current / Secondary output: 5A, accuracy 1%)
 * The STU acceptable voltage range is 100 to 250V
 * If you want an external VDM, please insert '(-V)' at the end of the full ordering

* The Self-Power function is to receive power from the main circuit inside the circuit breaker without external power to the STU Communication, ZSI, Remote Reset, DO functions are not available and EVENT is not logged when using Self - Power only.

Item	Description	Features	Remarks
72313460708	TOTAL ASS'Y/VDM(Shield Cable), EXTERNAL, STU	Accessory	Separate purchasing

* If you want to apply external VDM separately, please order the code above.

Layouts and dimensions

D-type (800~1600A)

Application rules

- 1) Feeder circuit breaker: up to 1600A
- 2) Main/Tie circuit breaker: up to 1600A
- 3) Frame size(W×H×D): 19.68"×91.73"×62.0" (500×2,330×1,575mm)
- 4) Bus bracing: Vertical 65kA, Horizontal 100kA
- 5) It consists of each compartment.
CB compartment can be provided separately.
- 6) The height of top & bottom cable raceway is 100mm each.
- 7) The height of 1 compartment is basically 520mm.
- 8) 2 or 3 compartments in a combined structure is available. (such as A')



D-type ACB



1 CB Module

Layout

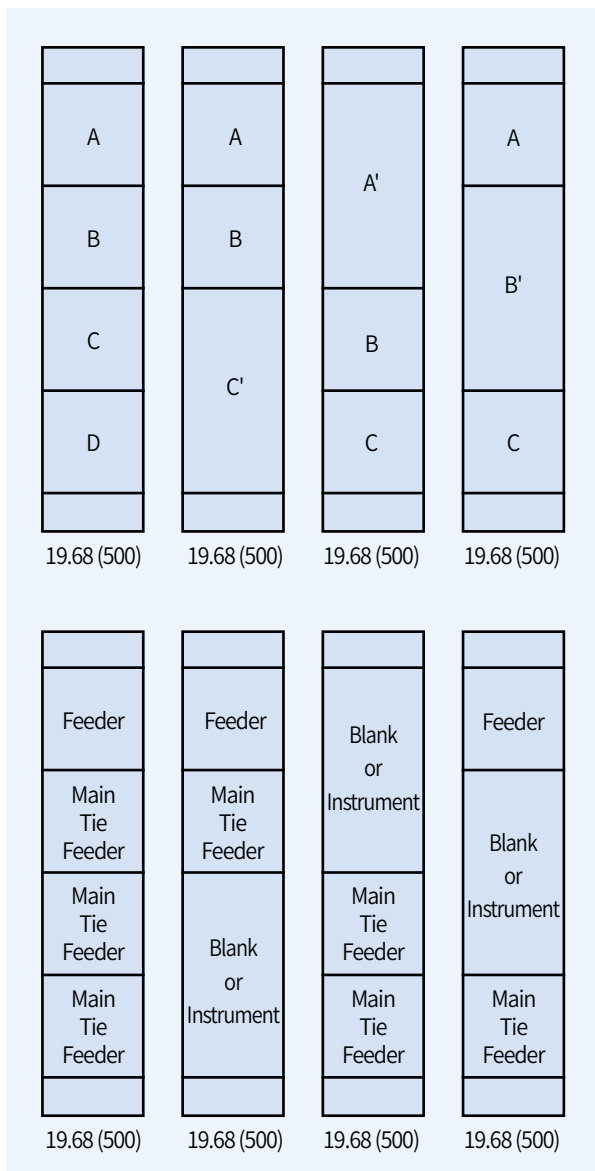

Available ampacity

Comp.	Available ampacity
A	800,1000,1200,1600A
B	800,1000,1200,1600A
C	800,1000,1200,1600A
D	800,1000,1200,1600A
A', B', C'	Blank, Instrument, LV compartment

Dimensions

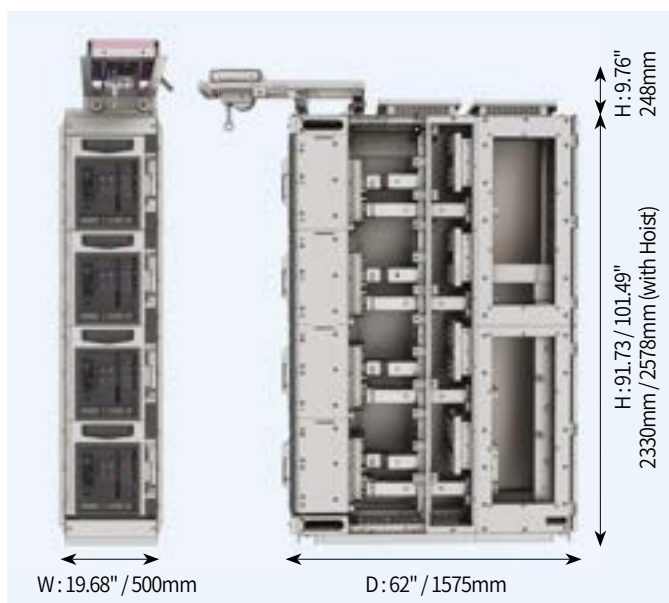

E-type (800~3200A)

Application rules

- 1) Feeder circuit breaker: up to 3200A
- 2) Main/Tie circuit breaker: up to 3200A
- 3) Frame size(W×H×D): 21.65"×91.73"×62.0"
(550×2,330×1,575mm)
- 4) Bus bracing: Vertical 85kA, Horizontal 100kA
- 5) It consists of each compartment.
CB compartment can be provided separately.
- 6) The height of top & bottom cable raceway is 100mm each.
- 7) The height of 1 compartment is basically 520mm.
- 8) 2 or 3 compartments in a combined structure is available. (such as A')



E-type ACB



1 CB Module

Layout

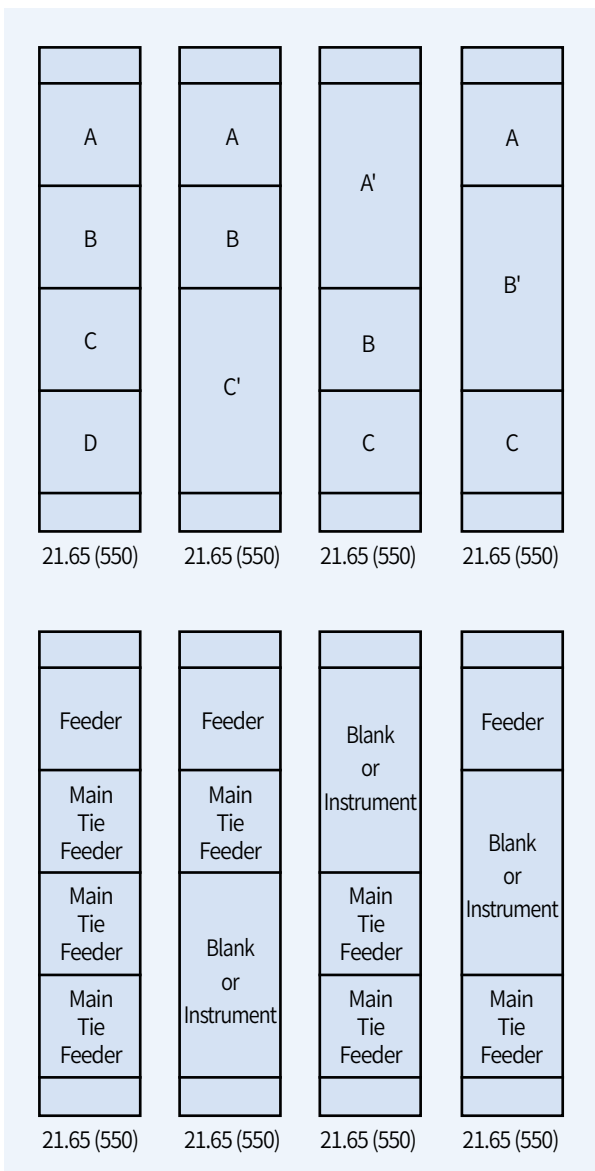

Available ampacity

Comp.	Available ampacity
A	800,1000,1200,1600,2000,2500A
B	800,1000,1200,1600,2000,2500,3200A
C	800,1000,1200,1600,2000,2500,3200A
D	800,1000,1200,1600,2000,2500,3200A
A', B', C'	Blank, Instrument, LV compartment

Dimensions

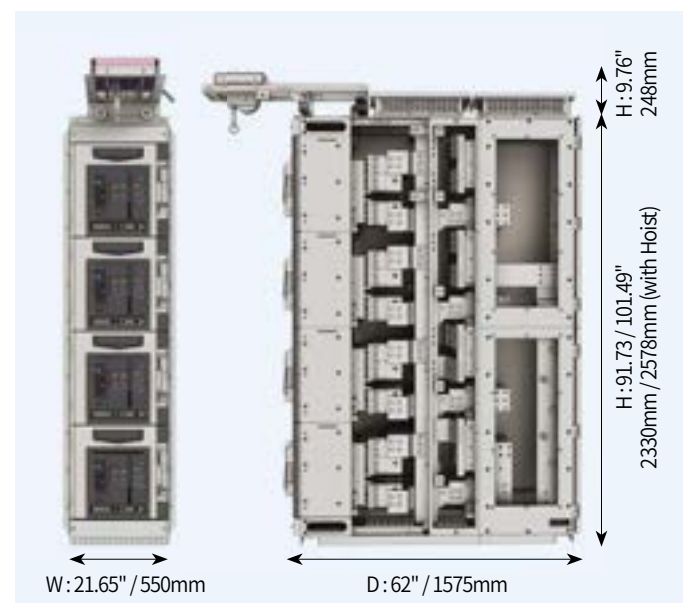

Layouts and dimensions

G-type (3200~6000A)

Application rules

- 1) Feeder circuit breaker: up to 6000A
- 2) Main/Tie circuit breaker: 3200, 4000, 5000A, 6000A
- 3) Frame size(W×H×D): 43.3"×91.73" ×71.85"
(1,100×2,330×1,825mm)
- 4) Bus bracing: Vertical 100kA, Horizontal 100kA
- 5) It consists of each compartment.
CB compartment can be provided separately.
- 6) The height of top & bottom cable raceway is 100mm each.
- 7) The height of 1 compartment is basically 1,040mm.
- 8) Half size compartment is available. (such as A')

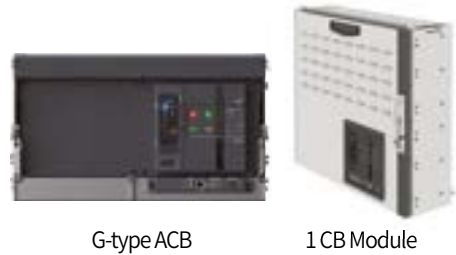

G-type ACB

1 CB Module

Layout

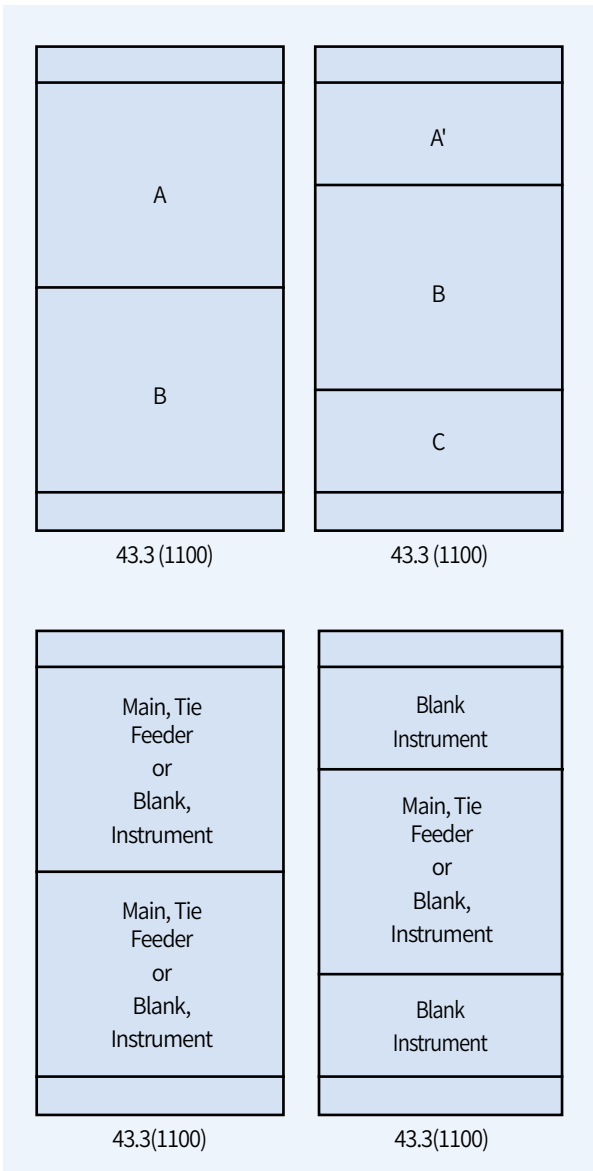

Available ampacity

Comp.	Available ampacity
A	3200,4000,5000,6000A
B	3200,4000,5000,6000A
A', C	Blank, Instrument, LV compartment

Dimensions

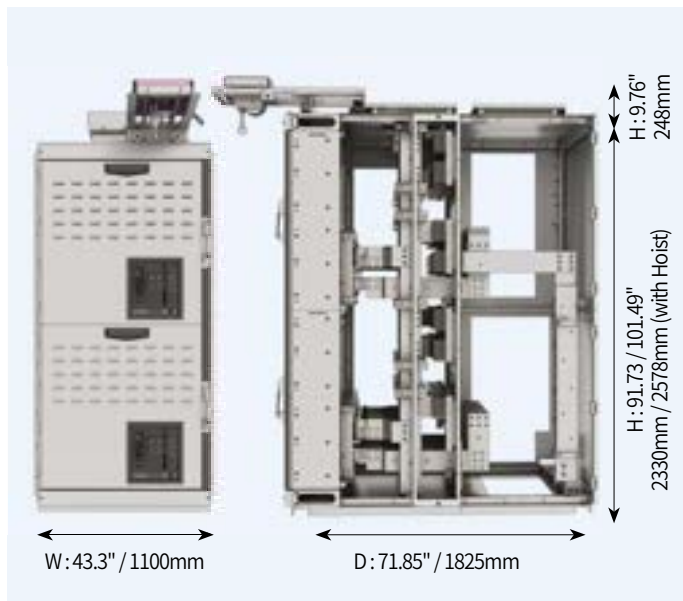

Bus

Application rules

- 1) All type horizontal busbar up to 6000A
- 2) D-type vertical busbar applied up to 1600A
- 3) E-type vertical busbar applied up to 4755A
- 4) G-type vertical busbar applied up to 6000A

Busbar data

D-type					E-type / G-type				
Current (A)	Number of busbar	Size (in ²)	Area [mm ²]	Current density	Current (A)	Number of busbar	Size (in ²)	Area [mm ²]	Current density
6000	6	6*1/4	5791	1.04	6000	6	6*1/4	5791	1.04
	8	5*1/4	6452	0.93		8	5*1/4	6452	0.93
5000	5	6*1/4	4826	1.04	5000	5	6*1/4	4826	1.04
	6	5*1/4	4839	1.03		6	5*1/4	4839	1.03
4000	4	5*1/4	3226	1.24	4000	4	5*1/4	3226	1.24
3200	3	5*1/4	2419	1.32	3200	3	5*1/4	2419	1.32
2500	3	4*1/4	1943	1.29	2500	3	4*1/4	1943	1.29
2000	2	4*1/4	1295	1.54	2000	2	4*1/4	1295	1.54
1600	2	3*1/4	968	1.65	1600	2	4*1/4	1295	1.24
1000/1200	2	3*1/4	968	1.24	1000/1200	1	4*1/4	806	1.49
800	1	3*1/4	484	1.65	800	1	3*1/4	648	1.24

Structure

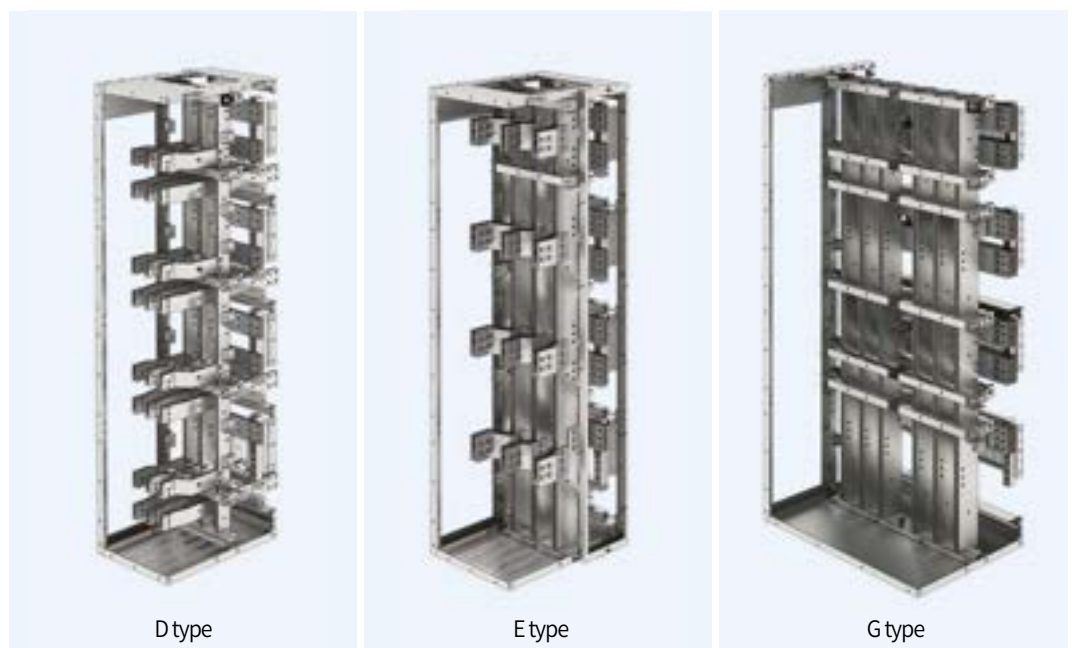

MEMO

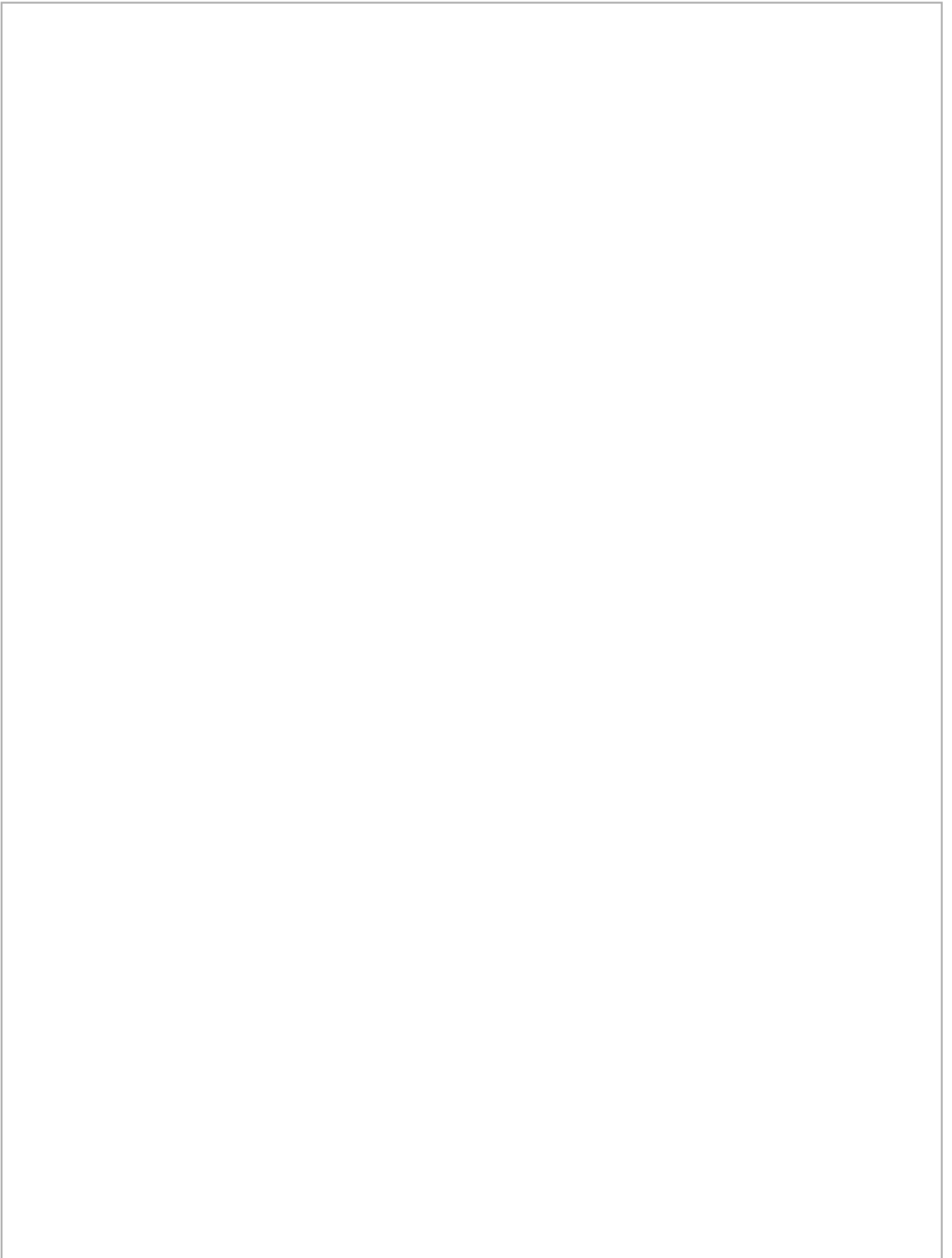

**LS ELECTRIC America Inc. Chicago Head Office**

625 Heathrow Dr, Lincolnshire, IL 60069, USA

Tel. 1-800-891-2941 E-Mail: sales.us@lselectricamerica.com

Headquarter

127 LS-ro (Hogye-dong) Dongan-gu, Anyang-si, Gyeonggi-Do, 14119, Korea

Seoul Office

LS Yongsan Tower, 92, Hangang-daero, Yongsan-gu, Seoul, 04386, Korea

Tel. 82-2-2034-4916, 4684, 4429

China

LS ELECTRIC (Dalian) Co., Ltd.

+86-411-8730-5872

china.dalian@lselectric.com.cn

LS ELECTRIC (Wuxi) Co., Ltd.

+86-510-6851-6666

china.wuxi@lselectric.com.cn

LS ELECTRIC (Lishui) Co., Ltd.

+86-578-6866-780

china.lishui@lselectric.com.cn

Shanghai Office

+86-21-5237-9977

china@lselectric.com.cn

Beijing Office

+86-10-5095-1631

china@lselectric.com.cn

Guangzhou Office

+86-20-3818-2883

china@lselectric.com.cn

Qingdao Office

+86-532-8501-2065

china@lselectric.com.cn

Chengdu Office

+86-28-8670-3201

china@lselectric.com.cn

Nanjing Office

+86-25-84 67-0005

china@lselectric.com.cn

India

India Office

+91-80-6142-9108

Info_india@ls-electric.com

Indonesia

PT. LS ELECTRIC INDONESIA

+62-21-2933-7614

indonesia@ls-electric.com

PT SYMPHOS ELECTRIC

+62-81-1900-1474

marketing@symphos-weltraf.com

Italy

Italy office

+39-030-8081-833

italia@ls-electric.com

Japan

LS ELECTRIC Japan Co., Ltd.

+81-3-6268-8241

japan@ls-electric.com

Tokyo Office

+81-3-6268-8241

tokyo@ls-electric.com

Netherlands

LS ELECTRIC Europe B.V.

+31-20-654-1424

europartner@ls-electric.com

Russia

Moscow Office

+7-499-682-6130

info@lselectric-ru.com

Singapore

Singapore Office

+65-6958-8162

singapore@ls-electric.com

Spain

LS ELECTRIC IBERIA S.L.U.

+34-910-28-02-74

iberia@ls-electric.com

Thailand

Bangkok Office

+66-2-128-0295

thailand@ls-electric.com

Türkiye

LS ELECTRIC Türkiye Co., Ltd.

+90-212-806-1252

turkiye@ls-electric.com

U.A.E

LS ELECTRIC Middle East FZE (Dubai)

+971-4-886-5360

middleeast@ls-electric.com

USA

LS ELECTRIC America Inc.

+1-800-891-2941

sales.us@lselectricamerica.com

LS ENERGY SOLUTIONS LLC

+1-980-221-0654

info@ls-es.com

MCM Engineering II

+1-435-865-0125

sales.us@lselectricamerica.com

America Western Office

+1-949-333-3140

america@ls-electric.com

America Bastrop Campus

+1-800-891-2941 EXT 2

power_support.us@lselectricamerica.com

Vietnam

LS ELECTRIC Vietnam Co., Ltd.

+84-222-2221-110

vietnam@ls-electric.com

Hanoi Office

+84-24-6275-8054

vietnam@ls-electric.com

Ho Chi Minh Office

+84-3823-7890

vietnam@ls-electric.com

Specifications in this catalog are subject to change without notice due to continuous product development and improvement

© 2020. 02 LS ELECTRIC Co., Ltd. All rights reserved. / English (04) 2025. 10. PACO STORY

www.LSElectricAmerica.com

Distributed by Gross Automation | +1 (262) 252-1600 | sales@grossautomation.com