

THIS COPY IS PROVIDED ON A RESTRICTED BASIS AND IS NOT TO BE USED IN ANY WAY DETRIMENTAL TO THE INTERESTS OF PANDUIT CORP.

PANDUIT INVENTORY NUMBERING SYSTEM

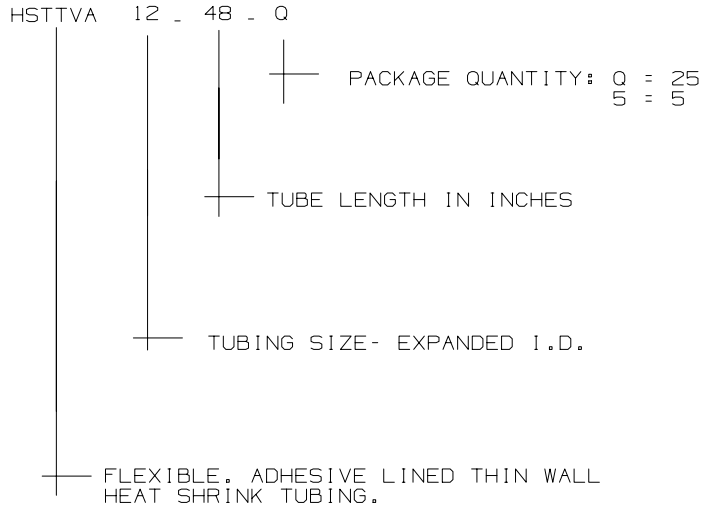

PANDUIT PART NUMBER	MIN. EXPAND. I.D. IN (MM)	MAX RECOV. I.D. IN (MM)	NOMINAL RECOV. WALL THICKNESS IN (MM)
HSTTVA12	.125 (3.2)	.063 (1.6)	.020 ± .008 (0.5 ± 0.2)
HSTTVA19	.187 (4.8)	.093 (2.4)	.024 ± .008 (0.6 ± 0.2)
HSTTVA25	.250 (6.4)	.125 (3.2)	.028 ± .008 (0.7 ± 0.2)
HSTTVA38	.375 (9.5)	.187 (4.8)	.028 ± .008 (0.7 ± 0.2)
HSTTVA50	.500 (12.7)	.250 (6.4)	.032 ± .008 (0.8 ± 0.2)
HSTTVA75	.750 (19.0)	.375 (9.5)	.035 ± .008 (0.9 ± 0.2)
HSTTVA100	1.000 (25.4)	.500 (12.7)	.043 ± .012 (1.1 ± 0.3)
HSTTVA150	1.500 (38.1)	.750 (19.0)	.047 ± .016 (1.2 ± 0.4)



NOTES:

- SHRINK RATIO: 2:1
- SHRINK RATIOS ARE APPROXIMATIONS; PLEASE REFER TO TABLE 1 FOR THE EXACT MINIMUM EXPANDED AND MAXIMUM RECOVERED I.D.'S.
- MATERIAL: CROSSLINKED POLYOLEFIN WITH ADHESIVE
- COLOR: BLACK
- "ALL WARRANTIES, INCLUDING MERCHANTABILITY AND FITNESS FOR A PARTICULAR PURPOSE, ARE EXCLUDED. (USER IS RESPONSIBLE TO DETERMINE SUITABILITY OF PRODUCT FOR INTENDED USE.)"

PART NUMBER		HSTTVA***	
TITLE		FLEXIBLE ADHESIVE LINED THIN WALL HEAT SHRINK (HSTTVA)	
CUSTOMER DRAWING			
ITEM REVISION NAME		G03597HN/00	
DATASET FILE NAME		G03597HN_DC_GB0239KN_00/00B	
MATERIAL		SEE NOTES	
DRAWING NUMBER		GB0239KN	
DRAWN BY	DATE	CHK	SCALE
LGG	05/14/03	ENG	NONE
SHEET 1 OF 1		A	

REV	DATE	BY	CHK	APR	DESCRIPTION	ECN
00B	08/30/23	MROB	KLN	MSAD	UPDATE NOM WALL THICKNESS & TOLERANCE	GAECN06899
R	05/14/03	LGG	JWWI	MJK	DRAWING RELEASE.	GB0239KN

D10100DA/20