

THIS COPY IS PROVIDED ON A RESTRICTED BASIS AND IS NOT TO BE USED IN ANY WAY DETRIMENTAL TO THE INTERESTS OF PANDUIT CORP.

△
3

PANDUIT PART NO.	'A' MAX.	'B'	'C' MIN.	'D' HOLE SIZE	REC. FAST.	STACKING HEIGHT 'H' WHEN USED WITH INTERMEDIATE STRAPS				WEIGHT lbs (gs) / 100 pcs.
FCBI1-S10	2.50 *[63.5]	2.08 [52.8]	1.04 [26.4]	.200 [5.1]	#10 (M5) SCREW	.8 [20.3]	2.0 [50.8]	3.7 [94]	5.2 [132.1]	.30 *[136.08]
FCBI2-S10	3.50 [88.9]	3.10 *[78.7]	2.04 [51.8]	.200 [5.1]	#10 (M5) SCREW	----	1.0 [25.4]	2.7 [68.6]	4.2 [106.7]	.43 *[195.04]
FCBI3-S10	4.52 [114.8]	4.12 [104.6]	3.04 [77.2]	.200 [5.1]	#10 (M5) SCREW	----	----	1.7 [43.2]	3.2 [81.3]	.48 *[217.72]

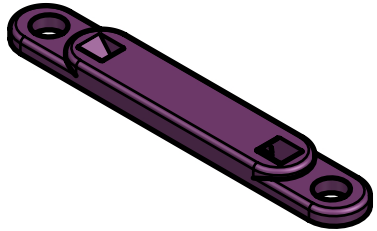

△
3

△
B

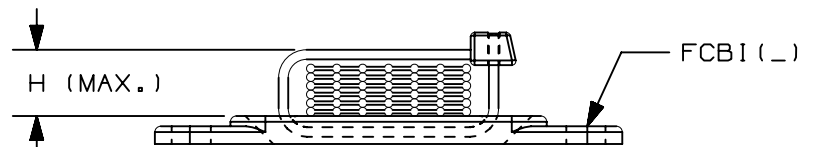
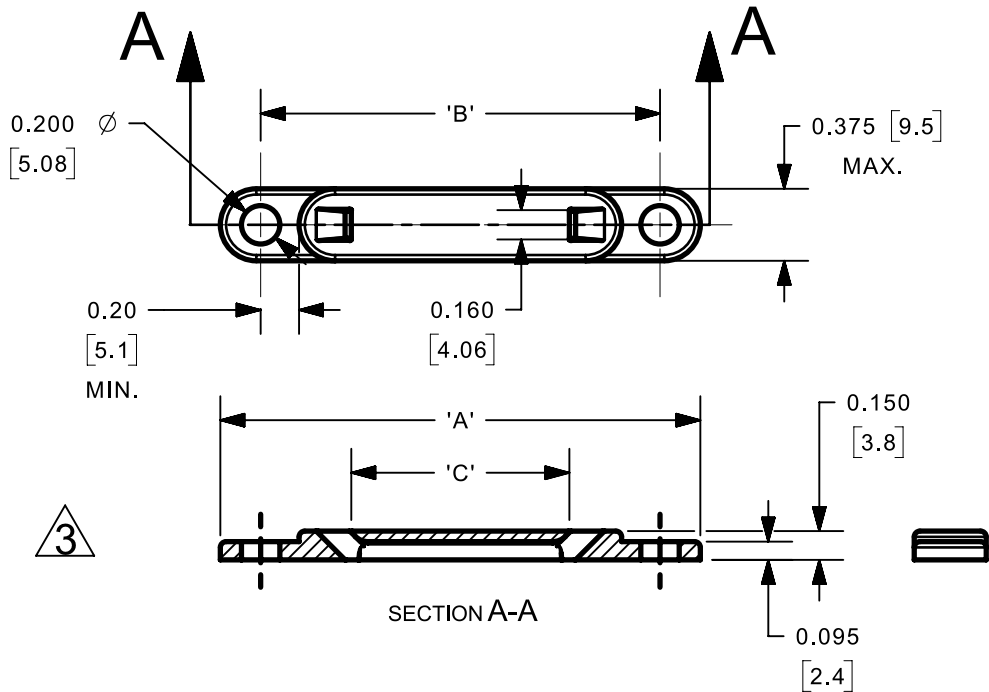

△
3

△
3

NOTES:

- * 1. SEE CURRENT PRICE SHEET FOR PART NUMBER SUFFIX DESIGNATIONS FOR PACKAGE SIZE.
- **2. CUSTOMER MUST FURNISH ADHESIVE.
- 3. PRODUCT CAN BE USED WITH PLATE FCP(_), REFER TO GB0239KV.
- 4. BAG MAY CONTAIN EXTRA PIECES TO COMPENSATE FOR VARIANCE IN THE PACKAGING PROCESS. PANDUIT ASSURES MINIMUM PIECE COUNT AS STATED ON THE BAG.

TITLE					
FLAT CABLE MOUNT BASE FCBI1, FCBI2, FCBI3 CUSTOMER DRAWING					
ITEM REVISION NAME			G03597FL/04		
DATASET FILE NAME			G03597FL_DC_GB0239HY/04A		
UNLESS OTHERWISE SPECIFIED, DIMENSIONAL TOLERANCES ARE: IN [mm]			MATERIAL:		
.x \pm .05 [1.3]			.xxx \pm 0.010 [0.25]		
.xx \pm .030 [.762]			ANGLES \pm 5 °		
			THIRD ANGLE PROJECTION		
DRAWN BY		DATE	CHK	SCALE	DRAWING NUMBER:
JAD		8/12/04	JHAC	NONE	GB0239HY
REV		DATE	BY	CHK	APR
DESCRIPTION		ECN	SHT 1 OF 1	SIZE	A

04A	09-06-24	BDK	JADE	DJSL	B. M5 WAS MS (TYPO) A. UPDATED METRIC DIMENSION AND WEIGHT CONVERSIONS MARKED BY ASTERISK	005877 r00
3	6/1/2021	RVU	JADE	RMHI	REBUILD MODEL AND UPDATE DRAWING. ADDED NOTE 4. REMOVED FCBI1-A, FCBI2-A AND FCBI3-A.	GAECN05612
2	5/16/18	RVU	DJW	JHAC	INCREASE TOLERANCE .XX FROM +/- .02 TO +/- .030.	GAECN04603
1	8/12/04	JAD			UPDATE NOTE 3, ADD * TO NOTE 1 & 2.	GB0239HY

2

1