

THIS COPY IS PROVIDED ON A RESTRICTED BASIS AND IS NOT TO BE USED IN ANY WAY DETRIMENTAL TO THE INTERESTS OF PANDUIT CORP.

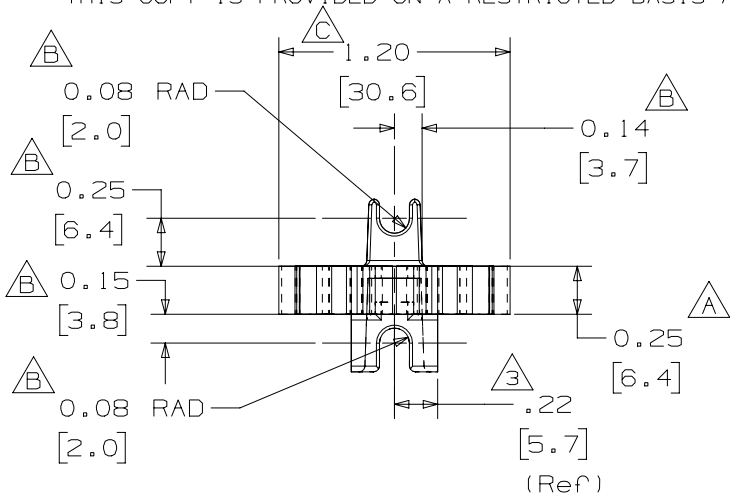

PANDUIT PART NUMBER	MAX. BUNDLE DIA. IN (MM)	REC'M FASTENER	WEIGHT lbs / 100pcs (g)
BR.75-E6	0.75 (19.)	#6 SCREW (M3)	0.86 (392)

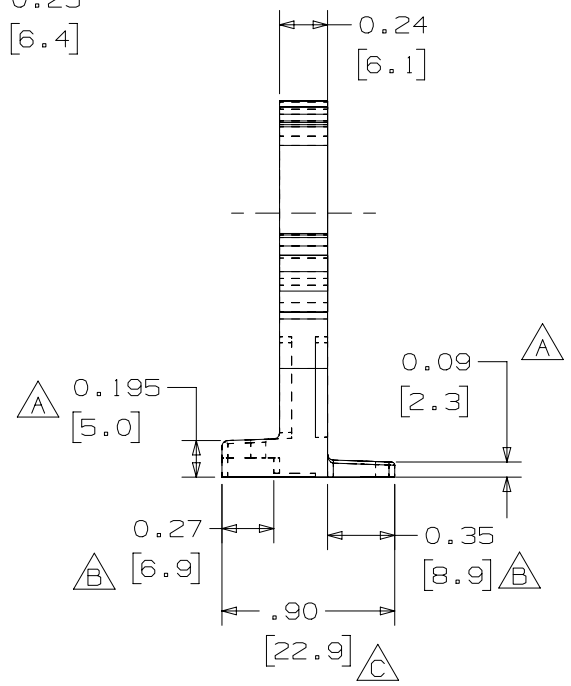
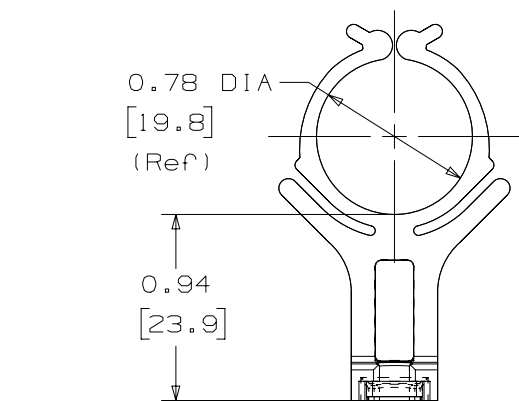

- NOTES:
- SEE <http://www.panduit.com> FOR PART NUMBER SUFFIX DESIGNATION FOR PACKAGE SIZE.
 - COLOR: BLACK

REV	DATE	BY	CHK	APR	DESCRIPTION	ECN
04A	3-18-24	MSAN	BWG	DJSL	C. CORRECTED INACCURATE DIMENSIONS. B. ADDED MISSING DIMENSIONS. A. CHANGED DIMENSIONS FROM REFERENCE TO DRIVING.	003456/00
3	10-03-11	BWG			ADDED MOUNTING HOLE CENTERS REF. DIMENSIONS. REVISED NOTE 1 TO SHOW PANDUIT WEBSITE	GB0239HN/03

TITLE					BUNDLE RETAINER, BR.75-E6				
ITEM REVISION NAME					CUSTOMER DRAWING				
DATASET FILE NAME					10B015DK/01				
UNLESS OTHERWISE SPECIFIED, DIMENSIONAL TOLERANCES ARE: IN [mm]									
.x ± 0.05 [1.3] .xxx ± 0.010 [0.25]									
.xx ± 0.02 [0.5] ANGLES ± 5 °					MATERIAL:				
					RUBBER MODIFIED NYLON 6/6				
					DRAWING NUMBER:				
					GB0239HN_DC				
DRAWN BY		DATE		CHK		SCALE		SIZE	
JAD		6-15-01				N/A		A	

D10100DA/21