

MOUNTING SPECS:

STUD SIZE: M8x1.25 - 6H ∇ 6.0[0.24]

STUD TORQUE: 13-20Nm

REVISION		
REV	DATE	DESCRIPTION
A	03/16/2017	517373GCP - RELEASED -TV
B	10/19/2017	518344ECP - REVISE MOUNTING SPEC NOTES -TV
C	8/30/18	519782ECP/D - CHG STUD TORQUE MRY
D	5/5/22	525159ECP/C - UPDATE HEIGHT, ADD TOLERANCES MRY
E	5/19/22	525232ECP/D - UPDATE LENGTH DIMENSION MRY

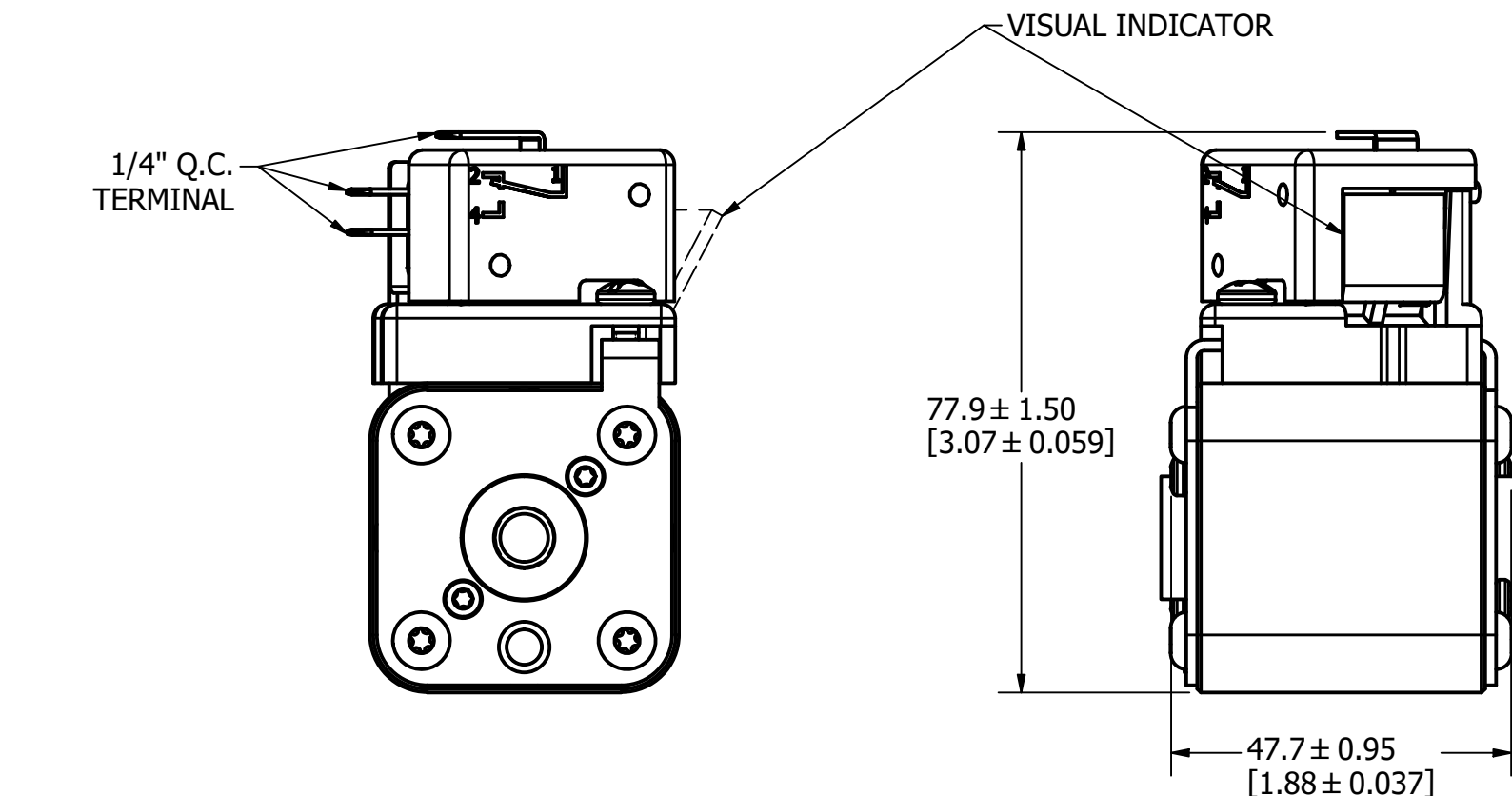
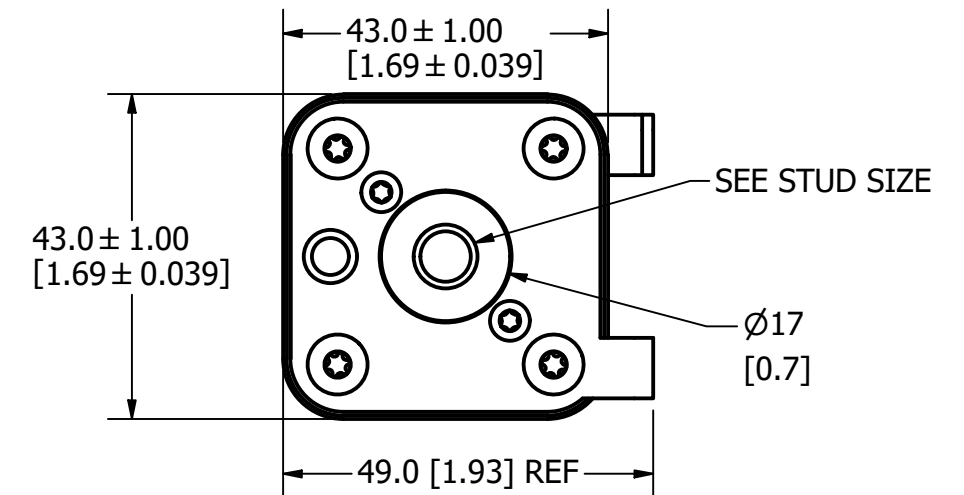
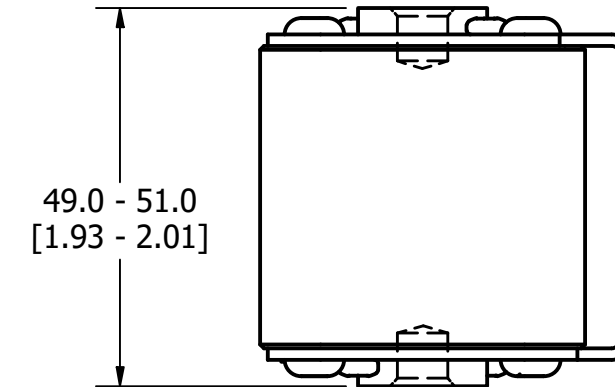
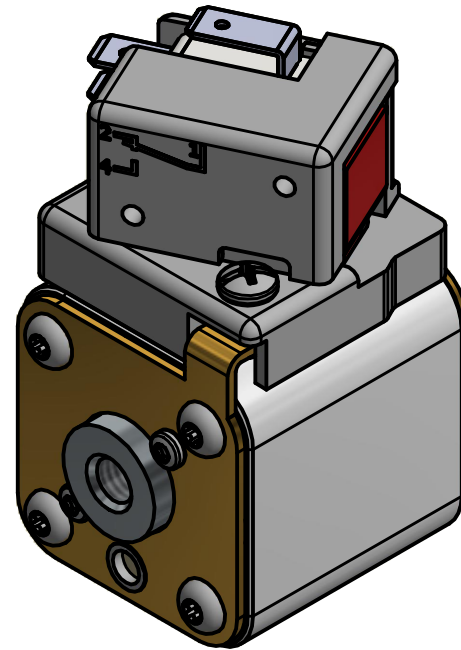
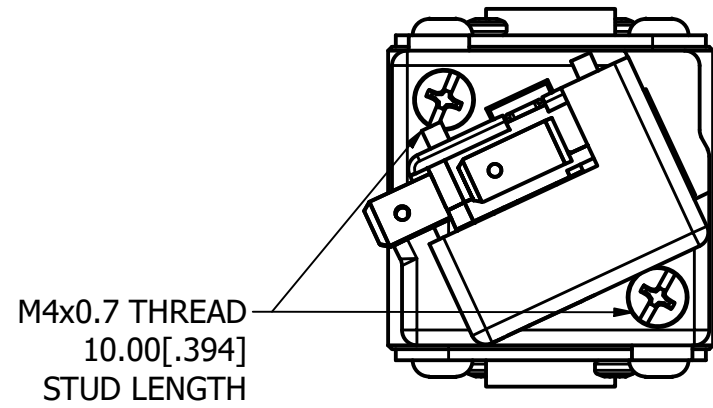

FUSE WITH MICROSWITCH

●	DENOTES CRITICAL CHARACTERISTICS.
CPK	DENOTES CPK DIMENSIONS, -MINIMUM CPK VALUE
⊳	DENOTES A CHARACTERISTIC THAT PROVIDES AN INDICATION OF PROCESS PERFORMANCE. PROCEDURE FOR MEASUREMENT AND TRACKING TO BE DEFINED IN LITTELFUSE INSPECTION INSTRUCTIONS.
CP	DENOTES CP DIMENSIONS, -MINIMUM CP VALUE MUST BE WITHIN THE DIMENSIONAL LIMITATIONS SHOWN ON DRAWING AND INITIALLY LOCATED TO ALLOW FOR MAXIMUM TOOL LIFE.

B

MATL SPEC	FINISH		
DRW TVESELSK	DATE 11/6/2013	SCALE NTS	FINISH GOOD WT GRAMS/PIECE

UNLESS OTHERWISE SPECIFIED, DIMENSIONS ARE IN MILLIMETERS, DIMENSIONS IN BRACKETS [] ARE INCHES DIMENSIONING AND DO NOT INCLUDE PLATING. TOLERANCING TO BE INTERPRETED IN ACCORDANCE WITH ANSI Y14.5M-1994



TITLE SQUARE BODY 30 CASE SIZE - METRIC THREAD OUTLINE

Littelfuse CHICAGO, ILLINOIS 60631	REVISION E	DRWG NO. OL-PSR030FL0000	SHEET 1 OF 1
--	----------------------	------------------------------------	--------------

REVISION		
REV	DATE	DESCRIPTION
A	08/11/2017	518016GCP - RELEASED -TV
B	10/19/2017	518344ECP - REVISE MOUNTING SPEC NOTES -TV
C	8/30/18	519782ECP/D - CHG STUD TORQUE MRY
D	5/5/22	525159ECP/D - CHANGE HEIGHT, ADD TOLERANCES MRY
E	5/19/22	525232ECP/D - UPDATE LENGTH DIMENSION MRY

MOUNTING SPECS:
 STUD SIZE: M8x1.25 - 6H ∇ 8.0[0.31]
 STUD TORQUE: 13-20Nm

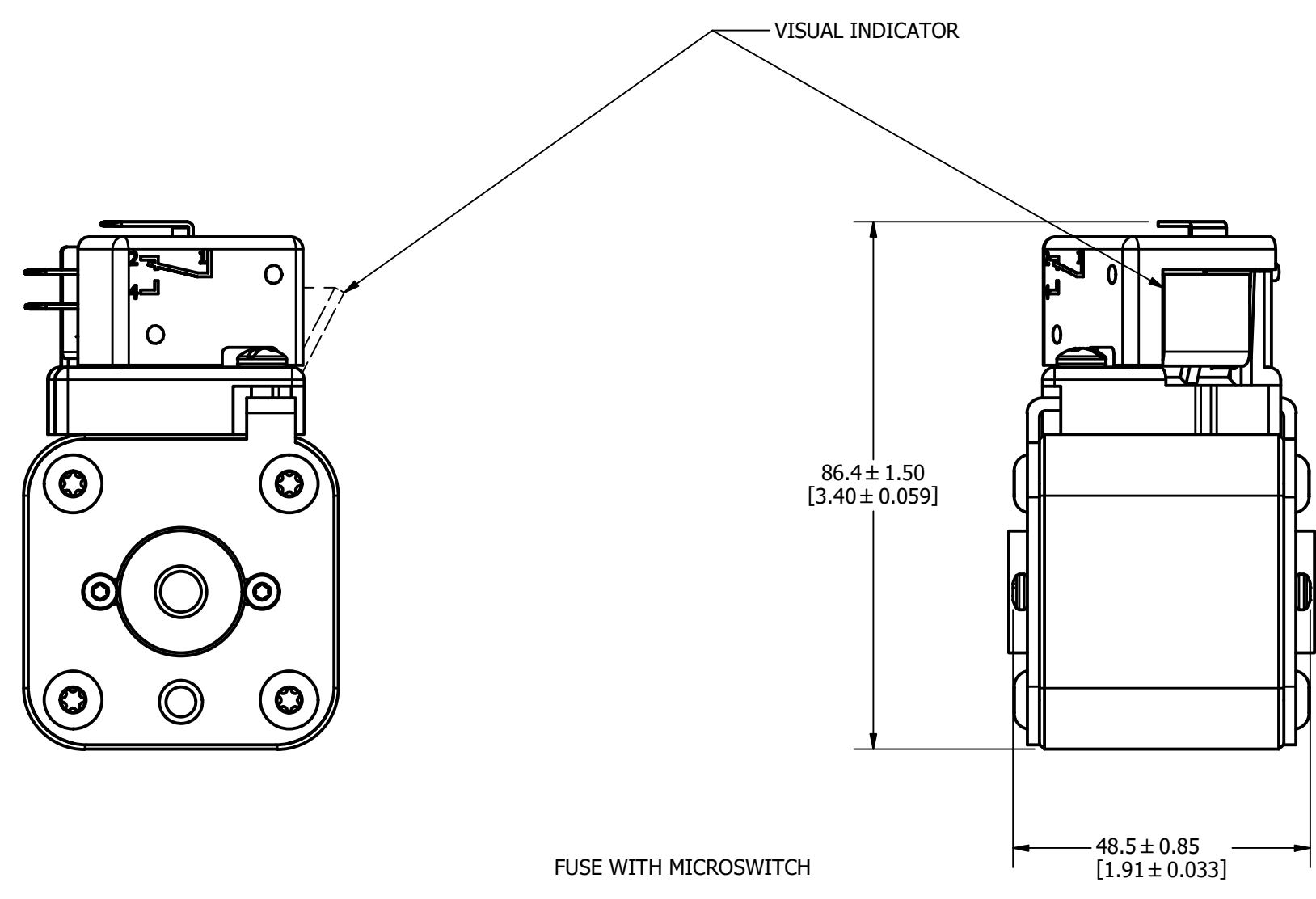
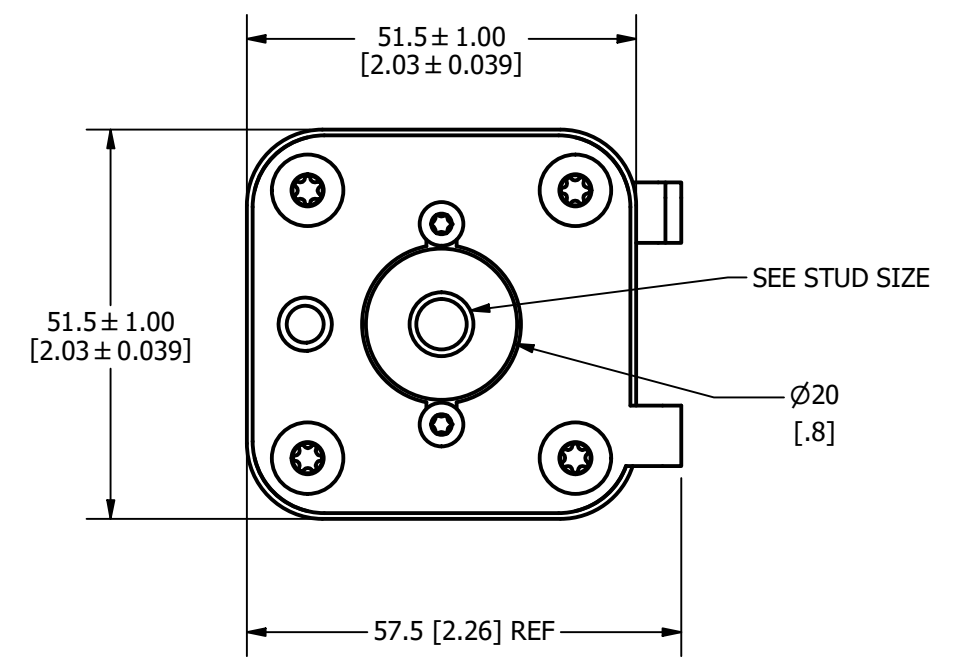
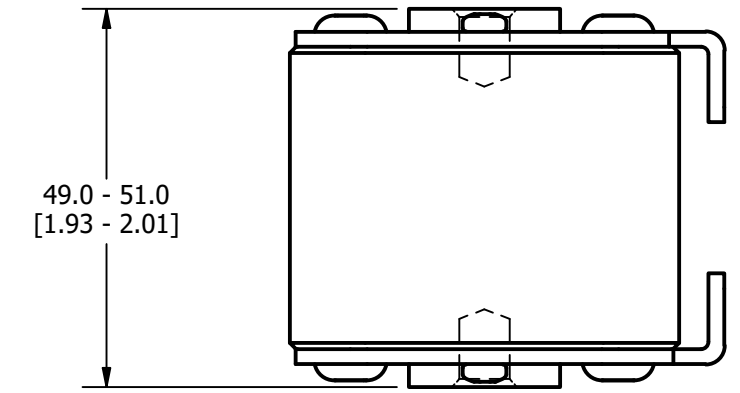
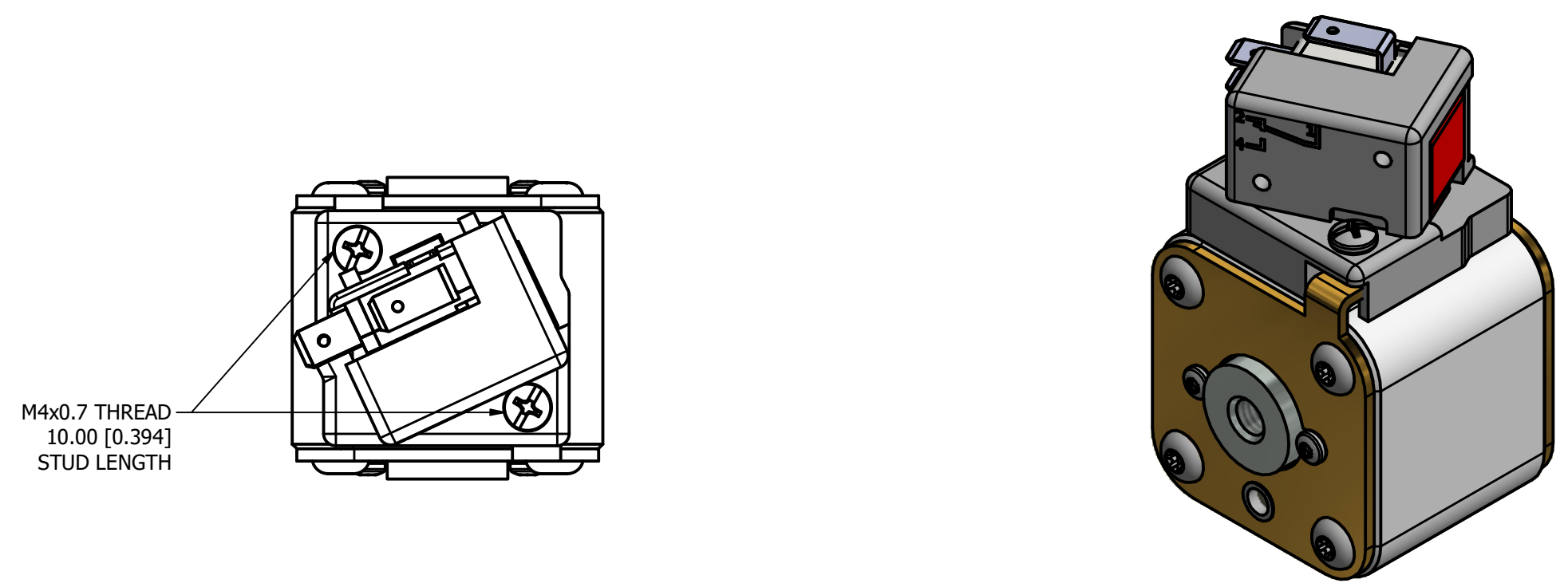

FUSE WITH MICROSWITCH

●	DENOTES CRITICAL CHARACTERISTICS.
CPK	DENOTES CPK DIMENSIONS, -MINIMUM CPK VALUE
(ST)	DENOTES A CHARACTERISTIC THAT PROVIDES AN INDICATION OF PROCESS PERFORMANCE. PROCEDURE FOR MEASUREMENT AND TRACKING TO BE DEFINED IN LITTELFUSE INSPECTION INSTRUCTIONS.
CP	DENOTES CP DIMENSIONS, -MINIMUM CP VALUE MUST BE WITHIN THE DIMENSIONAL LIMITATIONS SHOWN ON DRAWING AND INITIALLY LOCATED TO ALLOW FOR MAXIMUM TOOL LIFE.

MATL SPEC	FINISH		
DRW TVESELK	DATE 6/30/2017	SCALE NTS	FINISH GOOD WT GRAMS/PIECE

UNLESS OTHERWISE SPECIFIED, DIMENSIONS ARE IN MILLIMETERS, DIMENSIONS IN BRACKETS [] ARE INCHES DIMENSIONING AND DO NOT INCLUDE PLATING. TOLERANCING TO BE INTERPRETED IN ACCORDANCE WITH ANSI Y14.5M-1994

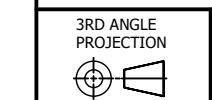

TITLE SQUARE BODY 31 CASE SIZE - METRIC THREAD OUTLINE

REVISION		
REV	DATE	DESCRIPTION
A	03/16/2016	517373GCP - RELEASED -TV
B	10/19/2017	518344ECP - REVISE MOUNTING SPEC NOTES -TV
C	8/30/18	519782ECP/D - CHG STUD TORQUE MRY
D	5/5/22	525159ECP/D - CHANGE HEIGHT, ADD TOLERANCES MRY
E	5/19/22	525232ECP/D - UPDATE LENGTH DIMENSION MRY

MOUNTING SPECS:

STUD SIZE: M10x1.5 - 6H ∇ 11.5 [0.45]

STUD TORQUE: 26-35Nm

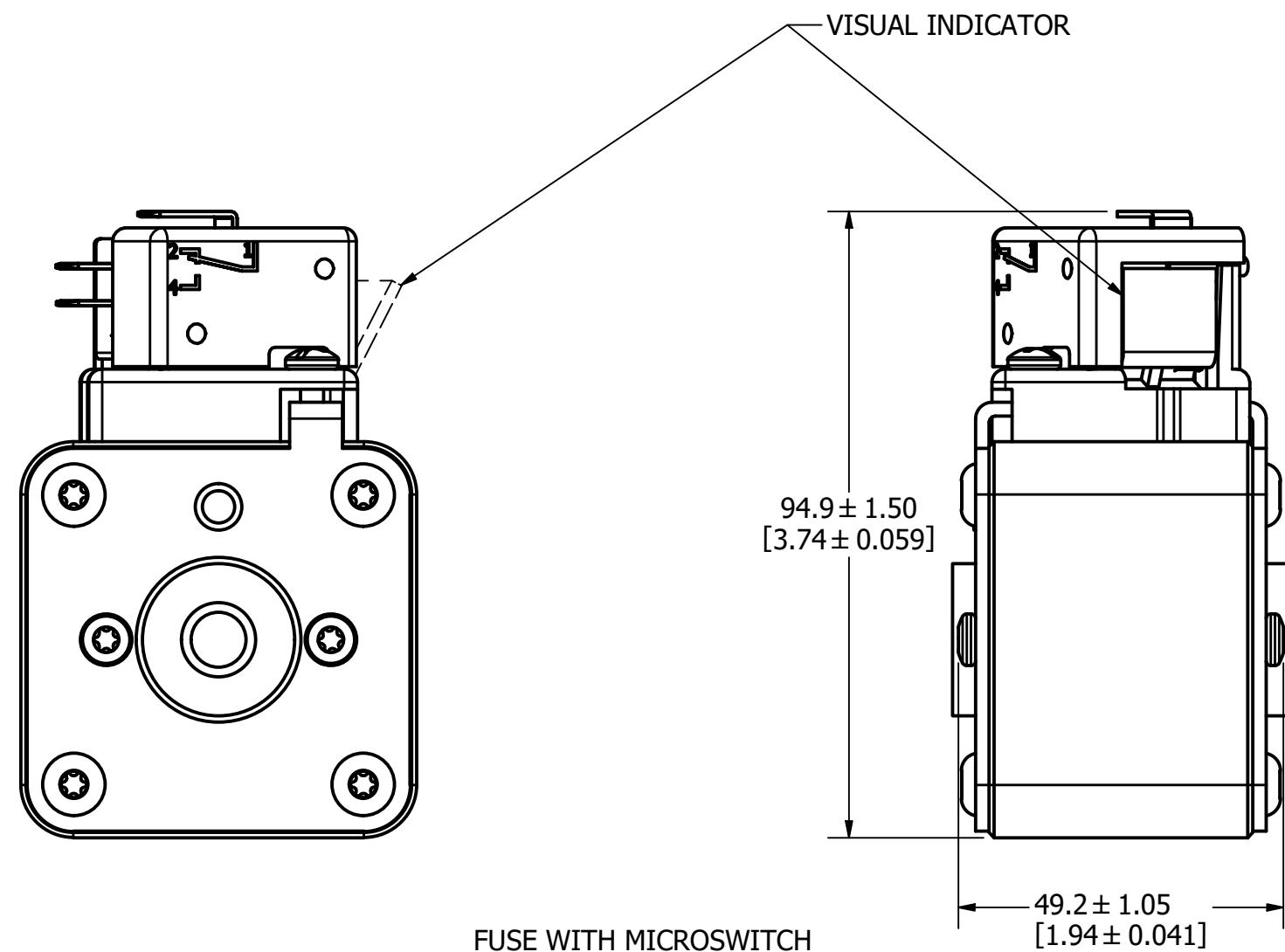
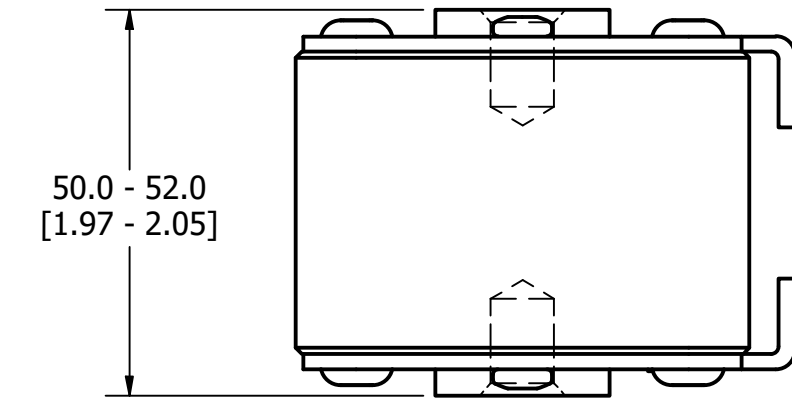
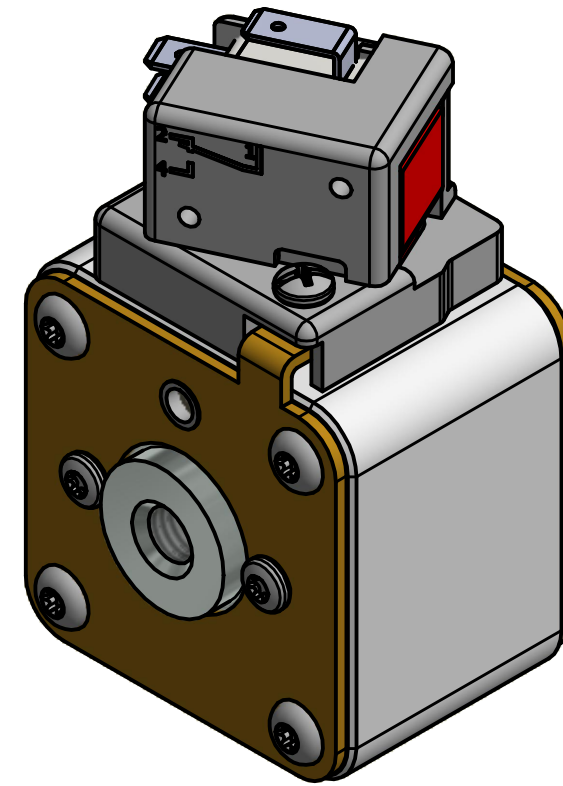
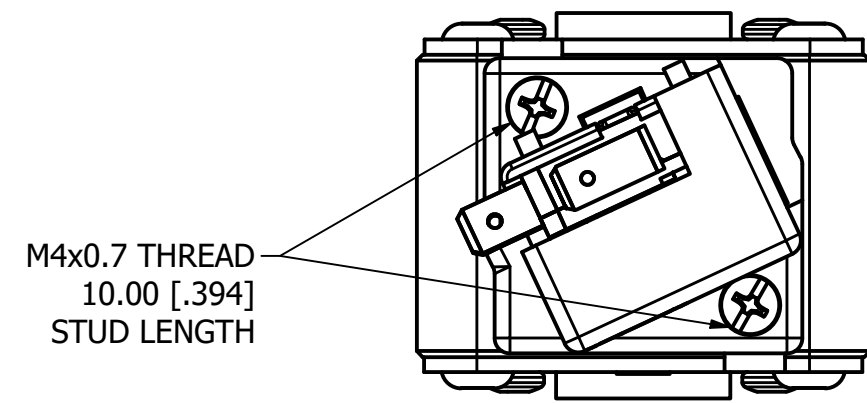

FUSE WITH MICROSWITCH

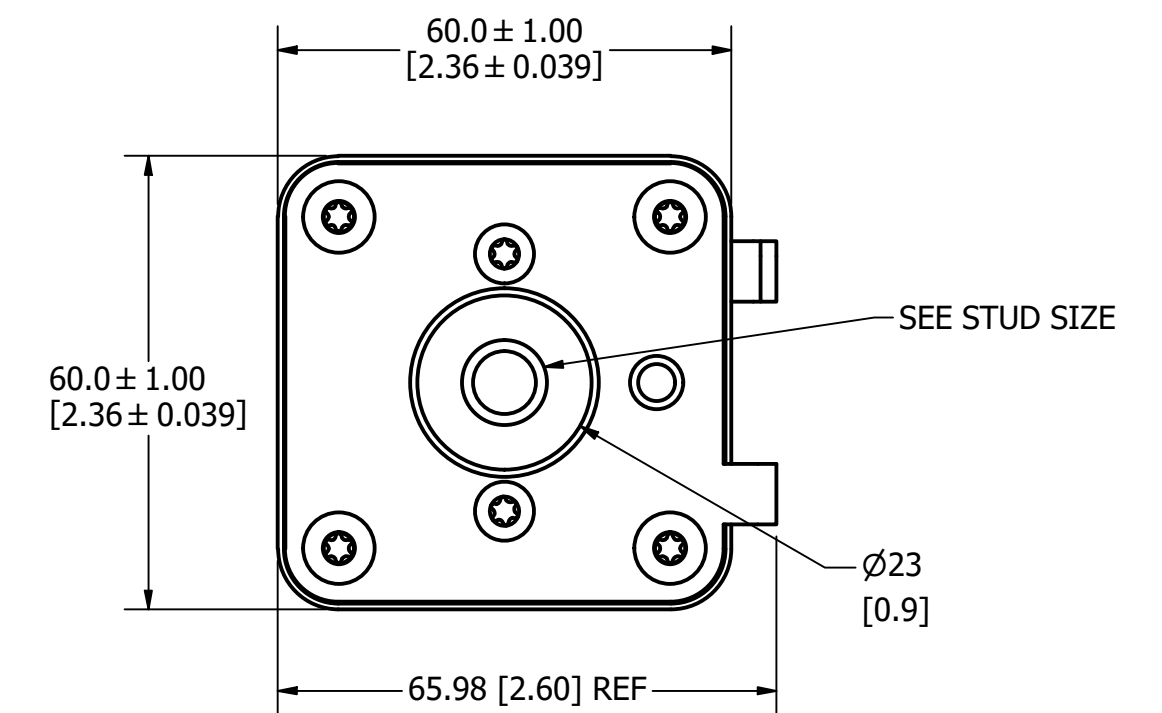

●	DENOTES CRITICAL CHARACTERISTICS.
CPK	DENOTES CPK DIMENSIONS, -MINIMUM CPK VALUE
(ST)	DENOTES A CHARACTERISTIC THAT PROVIDES AN INDICATION OF PROCESS PERFORMANCE. PROCEDURE FOR MEASUREMENT AND TRACKING TO BE DEFINED IN LITTELFUSE INSPECTION INSTRUCTIONS.
CP	DENOTES CP DIMENSIONS, -MINIMUM CP VALUE. MUST BE WITHIN THE DIMENSIONAL LIMITATIONS SHOWN ON DRAWING AND INITIALLY LOCATED TO ALLOW FOR MAXIMUM TOOL LIFE.

MATL SPEC	FINISH		
DRW TVESELSK	DATE 11/6/2013	SCALE NTS	FINISH GOOD WT GRAMS/PIECE

UNLESS OTHERWISE SPECIFIED, DIMENSIONS ARE IN MILLIMETERS, DIMENSIONS IN BRACKETS [] ARE INCHES DIMENSIONING AND DO NOT INCLUDE PLATING. TOLERANCING TO BE INTERPRETED IN ACCORDANCE WITH ANSI Y14.5M-1994

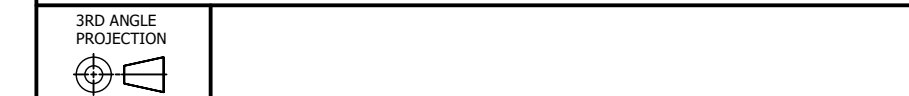

TITLE SQUARE BODY 32 CASE SIZE - METRIC THREAD OUTLINE

REVISION		
REV	DATE	DESCRIPTION
A	03/16/2016	517373GCP - RELEASED -TV
B	10/19/2017	518344ECP - REVISE STUD SIZE NOTES -TV
C	8/30/18	519782ECP/D - CHG STUD TORQUE MRY
D	5/5/22	525159ECP/D - CHANGE HEIGHT, ADD TOLERANCES MRY
E	5/19/22	525232ECP/D - UPDATE LENGTH DIMENSION MRY

MOUNTING SPECS:

STUD SIZE: M12x1.75-6H ∇ 13.0[0.51]

STUD TORQUE: 45-55Nm

M4x0.7 THREAD
10.00 [.394]
STUD LENGTH

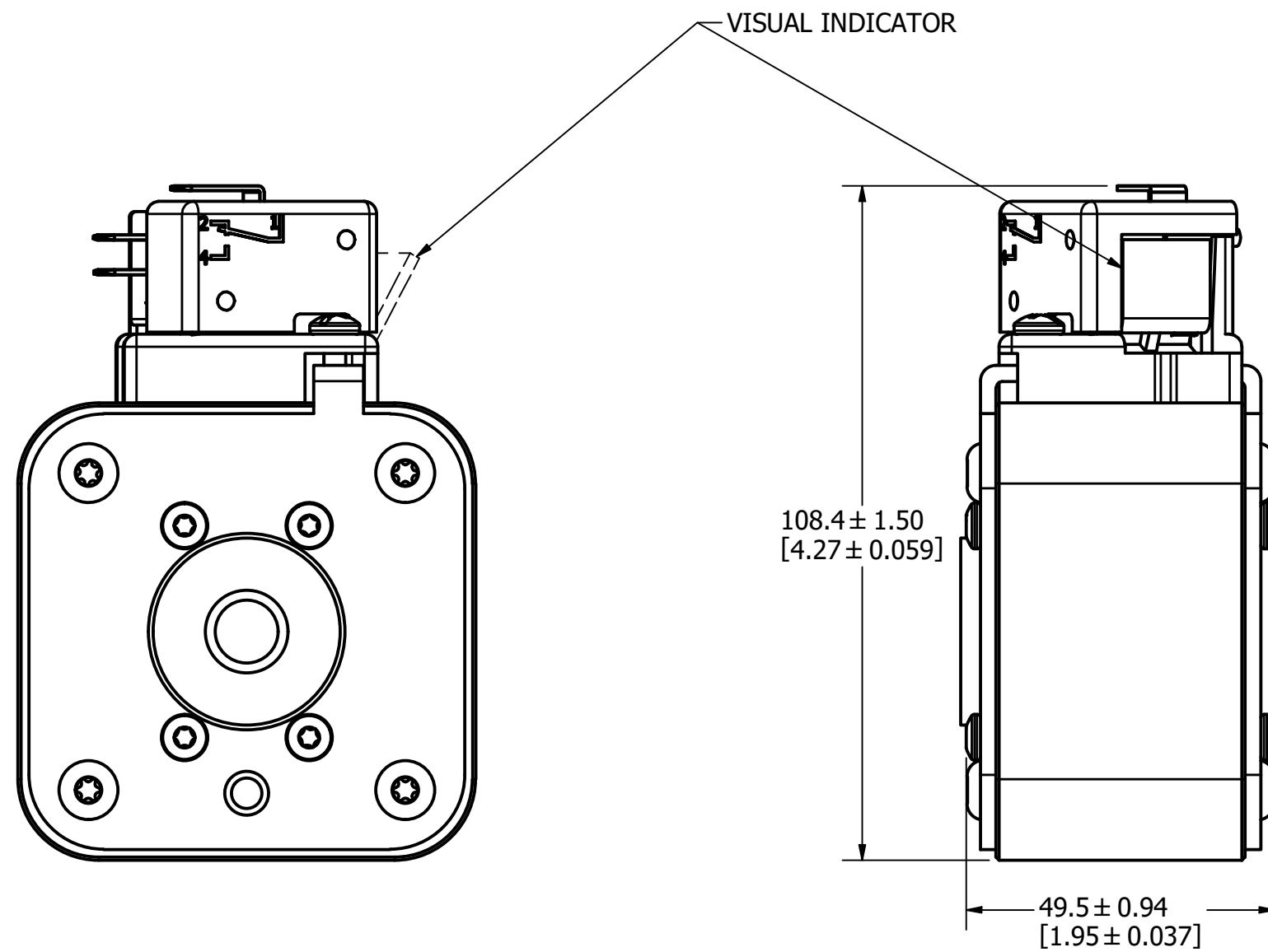
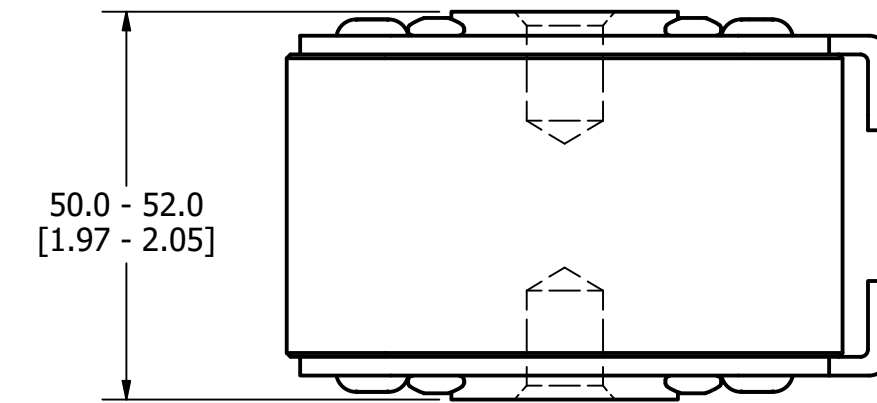
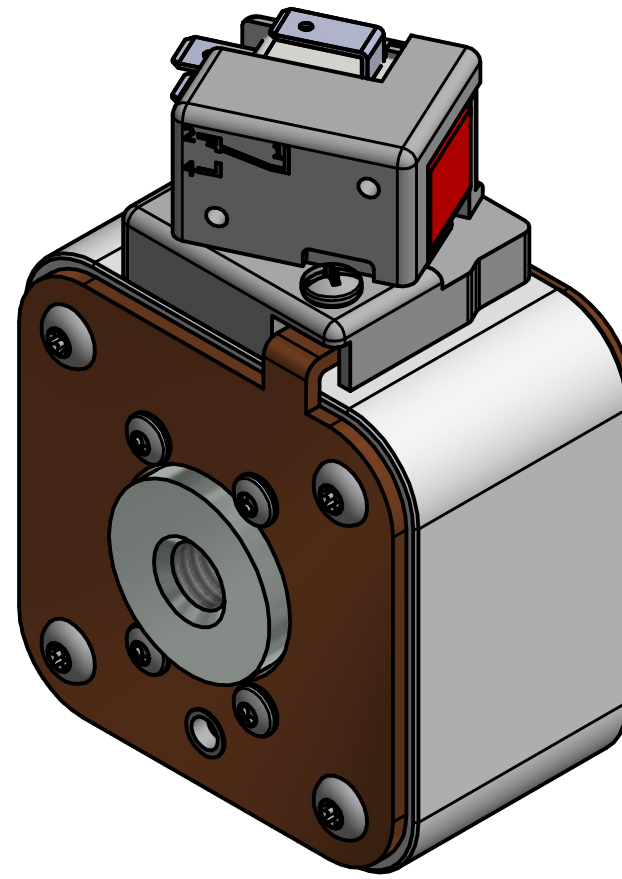
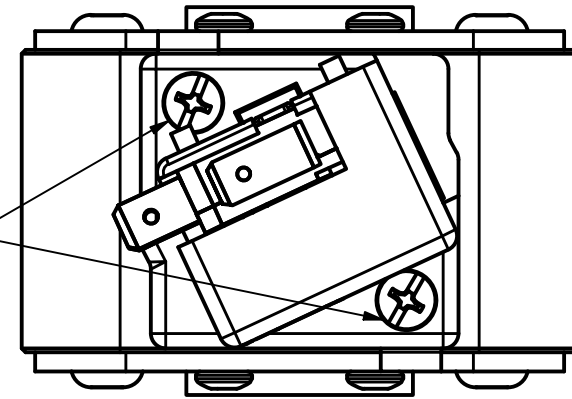

FUSE WITH MICROSWITCH

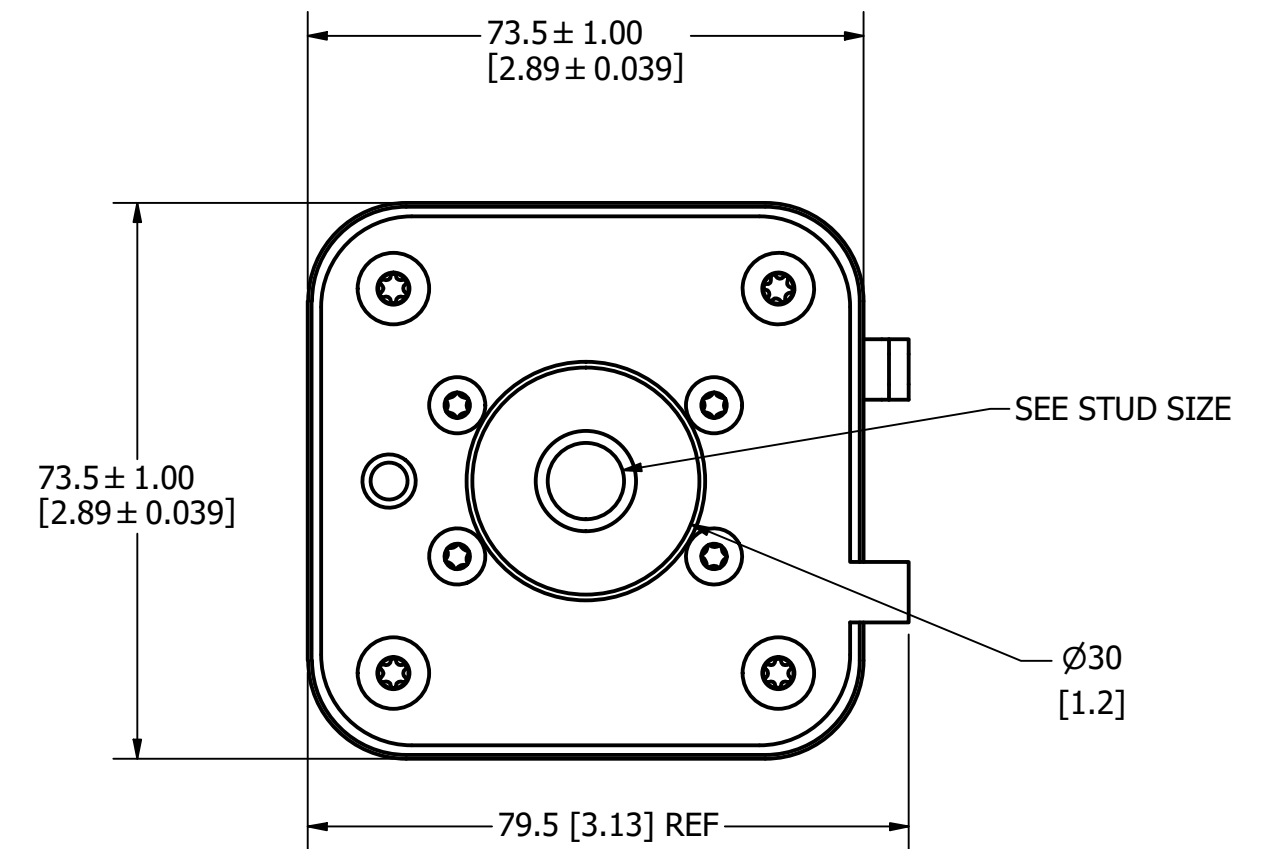

●	DENOTES CRITICAL CHARACTERISTICS.
CPK	DENOTES CPK DIMENSIONS, -MINIMUM CPK VALUE
(ST)	DENOTES A CHARACTERISTIC THAT PROVIDES AN INDICATION OF PROCESS PERFORMANCE. PROCEDURE FOR MEASUREMENT AND TRACKING TO BE DEFINED IN LITTELFUSE INSPECTION INSTRUCTIONS.
CP	DENOTES CP DIMENSIONS, -MINIMUM CP VALUE MUST BE WITHIN THE DIMENSIONAL LIMITATIONS SHOWN ON DRAWING AND INITIALLY LOCATED TO ALLOW FOR MAXIMUM TOOL LIFE.

MATL SPEC	FINISH		
DRW TVESELSK	DATE 11/6/2013	SCALE NTS	FINISH GOOD WT GRAMS/PIECE

UNLESS OTHERWISE SPECIFIED, DIMENSIONS ARE IN MILLIMETERS, DIMENSIONS IN BRACKETS [] ARE INCHES DIMENSIONING AND DO NOT INCLUDE PLATING. TOLERANCING TO BE INTERPRETED IN ACCORDANCE WITH ANSI Y14.5M-1994



TITLE SQUARE BODY 33 CASE SIZE - METRIC THREAD OUTLINE

REVISION		DESCRIPTION
REV	DATE	
A	01/10/2019	518685GCP - RELEASED -TV
B	8/30/18	519782ECP/D - CHG STUD TORQUE MRY
C	5/5/22	525161ECP/D - CHANGE HEIGHT, ADD TOLERANCES MRY
D	5/19/22	525232ECP/D - UPDATE LENGTH DIMENSION MRY

MOUNTING SPECS

STUD SIZE: M8x1.25-6H ∇ 6.0 [0.24]

STUD TORQUE: 13-20Nm

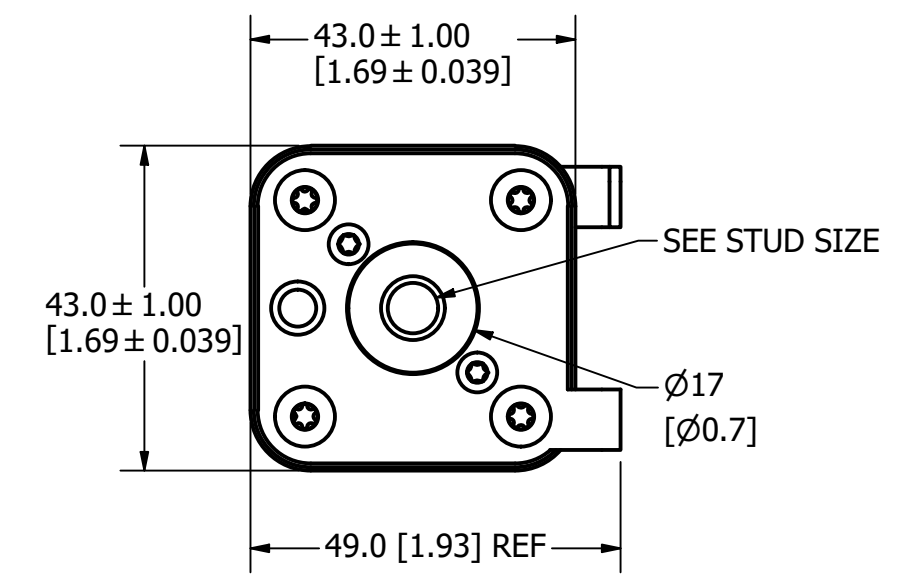
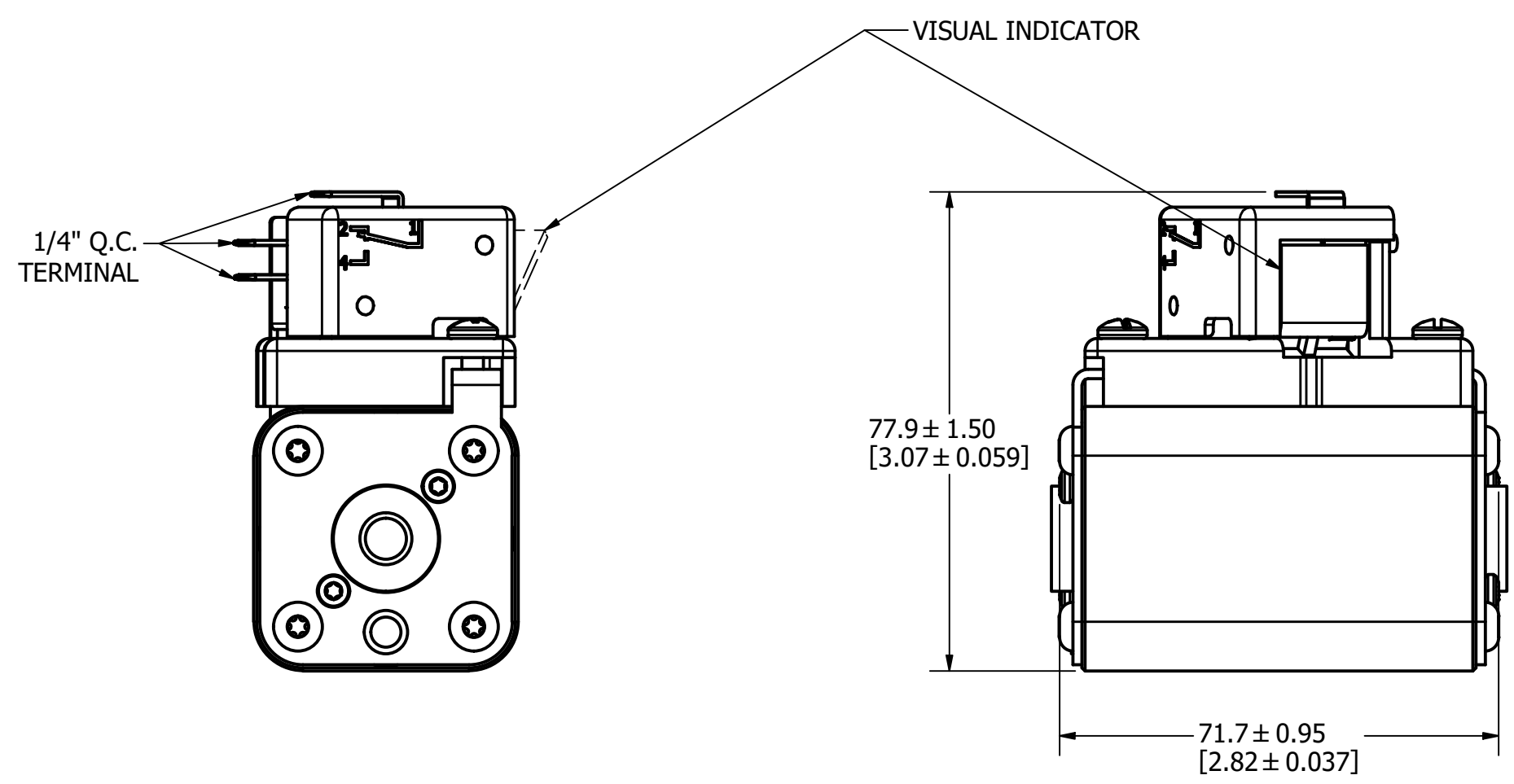
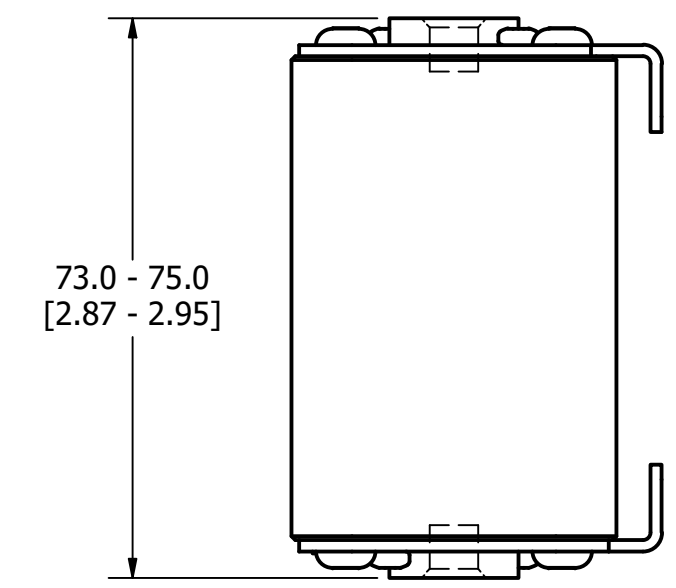
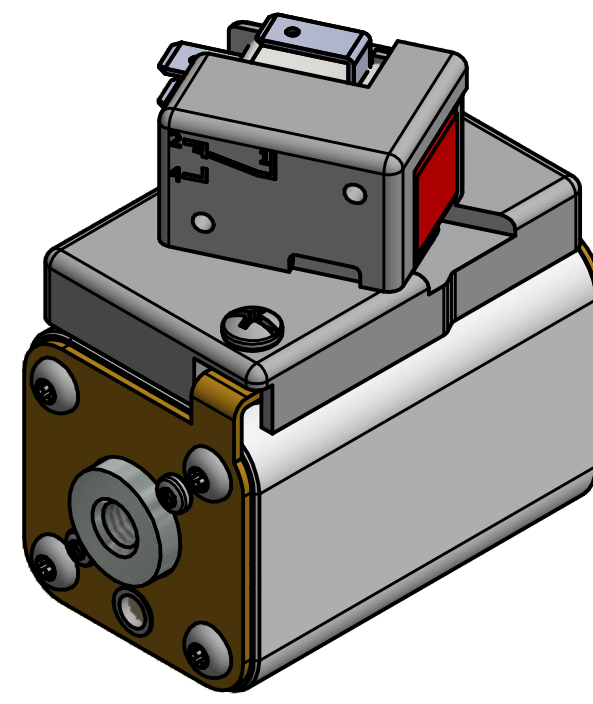
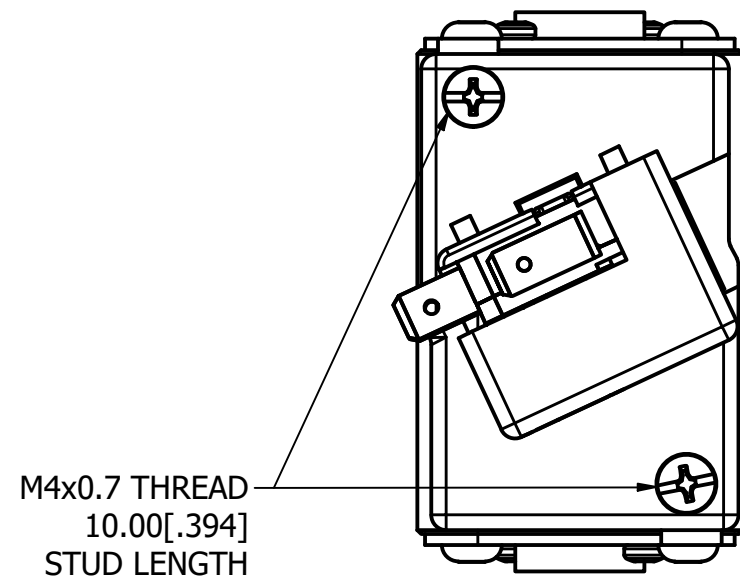

FUSE WITH MICROSWITCH

●	DENOTES CRITICAL CHARACTERISTICS.		
CPK	DENOTES CPK DIMENSIONS, -MINIMUM CPK VALUE		
(ST)	DENOTES A CHARACTERISTIC THAT PROVIDES AN INDICATION OF PROCESS PERFORMANCE. PROCEDURE FOR MEASUREMENT AND TRACKING TO BE DEFINED IN LITTELFUSE INSPECTION INSTRUCTIONS.		
CP	DENOTES CP DIMENSIONS, -MINIMUM CP VALUE MUST BE WITHIN THE DIMENSIONAL LIMITATIONS SHOWN ON DRAWING AND INITIALLY LOCATED TO ALLOW FOR MAXIMUM TOOL LIFE.		
MATL SPEC	FINISH		
DRW TVESELSK	DATE 11/6/2013	SCALE NTS	FINISH GOOD WT GRAMS/PIECE
UNLESS OTHERWISE SPECIFIED, DIMENSIONS ARE IN MILLIMETERS, DIMENSIONS IN BRACKETS [] ARE INCHES DIMENSIONING AND DO NOT INCLUDE PLATING. TOLERANCING TO BE INTERPRETED IN ACCORDANCE WITH ANSI Y14.5M-1994			
3RD ANGLE PROJECTION			
TITLE SQUARE BODY 70 CASE SIZE - METRIC THREAD OUTLINE			
CHICAGO, ILLINOIS 60631		REVISION D	DRWG NO. OL-PSR070FL0000 SHEET 1 OF 1

REVISION		
REV	DATE	DESCRIPTION
A	03/16/2016	517373GCP - RELEASED -TV
B	10/19/2017	518344ECP - REVISE MOUNTING SPEC NOTES -TV
C	8/30/18	519782ECP/D - CHG STUD TORQUE MRY
D	5/5/22	525161ECP/D - CHANGE HEIGHT, ADD TOLERANCES MRY
E	5/19/22	525232ECP/D - UPDATE LENGTH DIMENSION MRY

MOUNTING SPECS

STUD SIZE: M8x1.25 - 6H ∇ 8.0[0.31]

STUD TORQUE: 13-20Nm

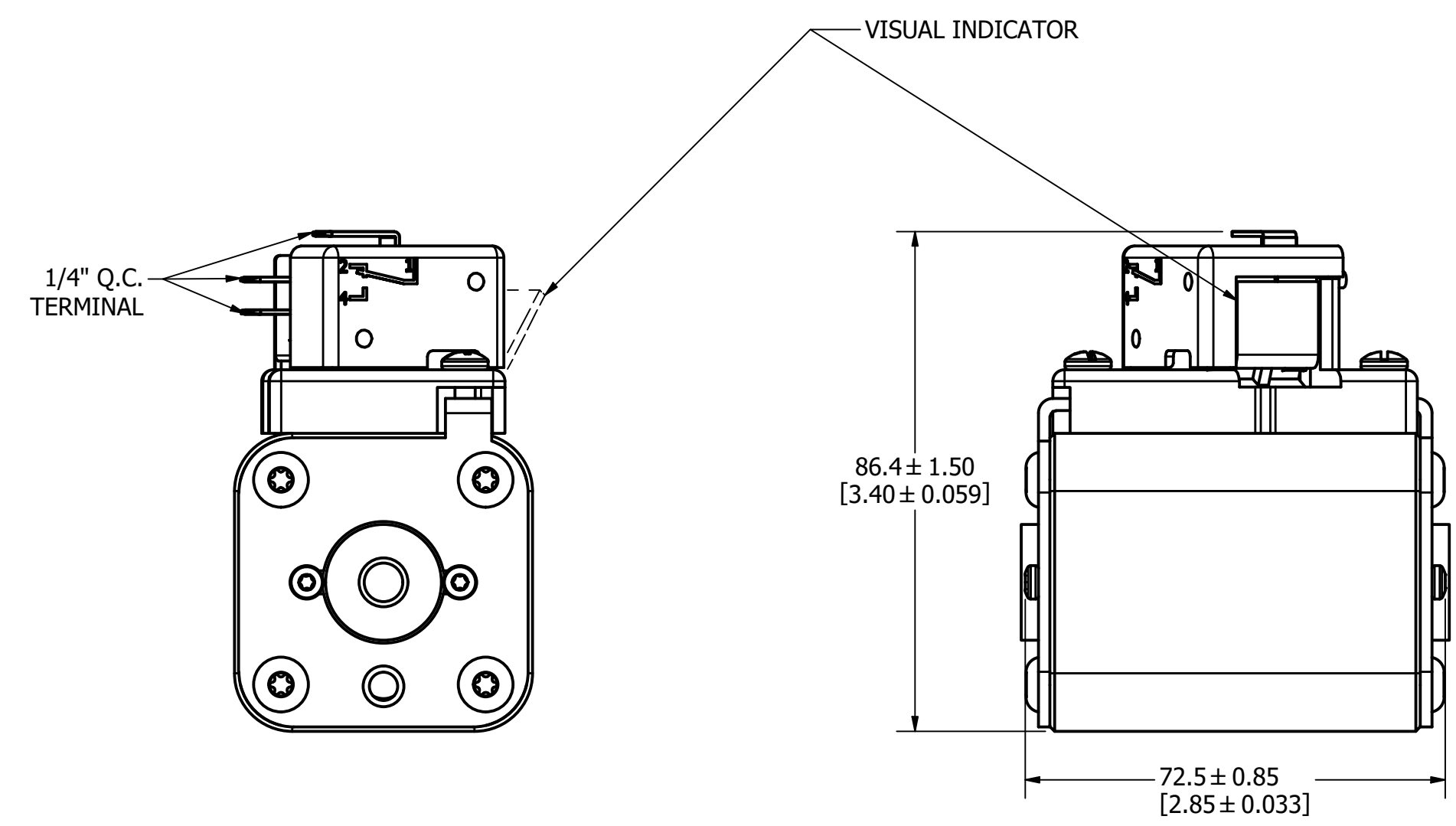
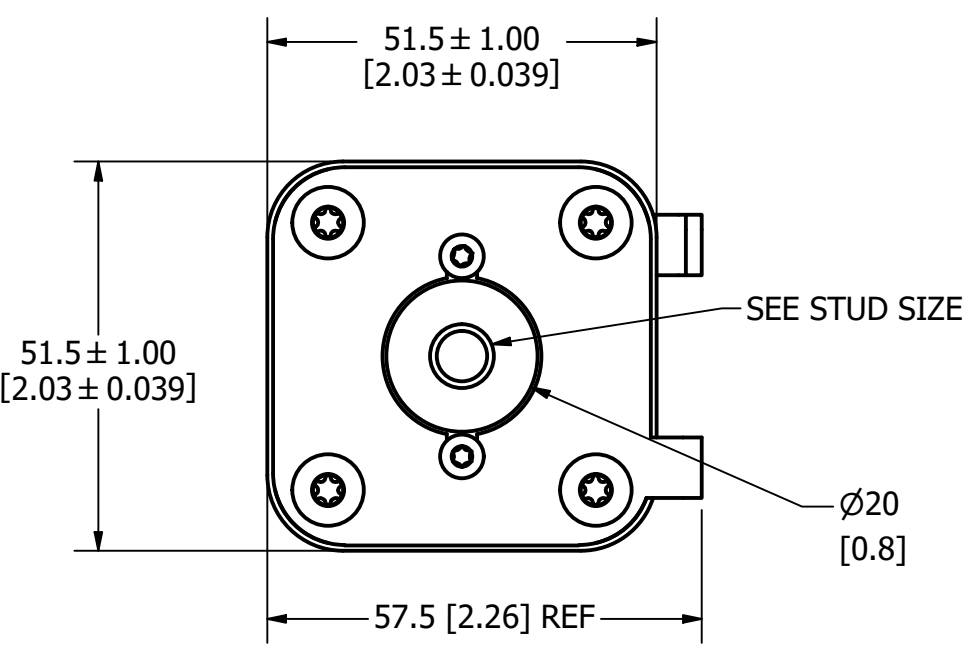
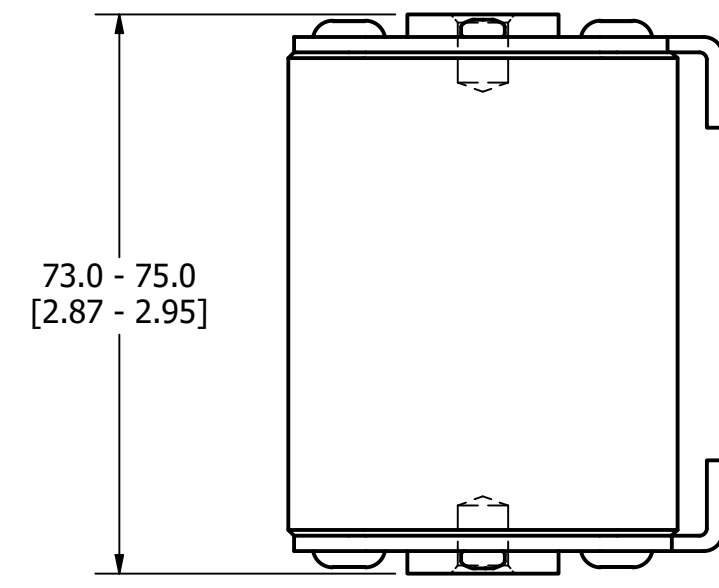
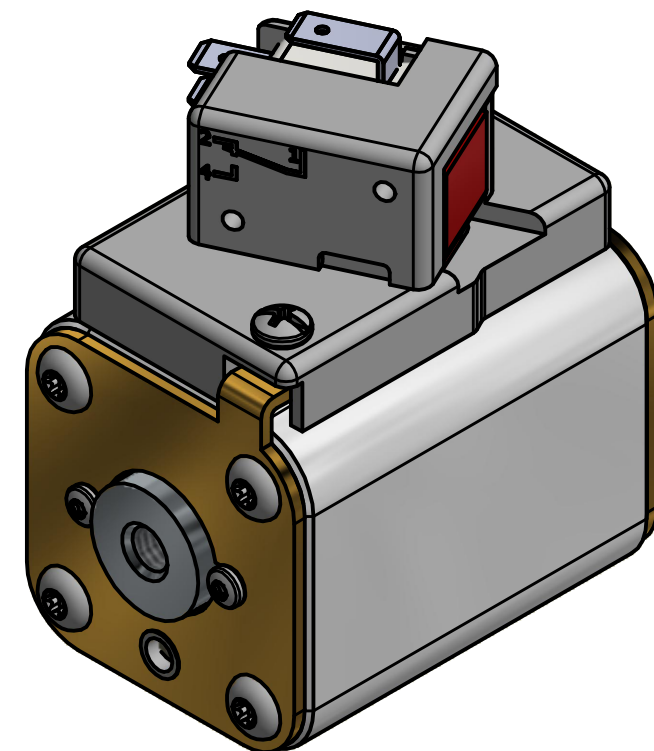
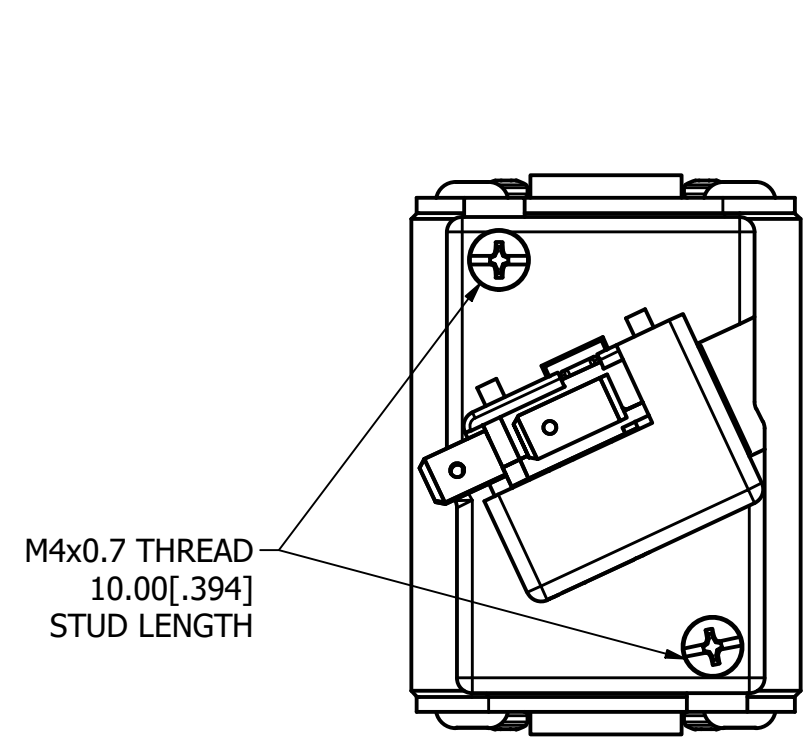

FUSE WITH MICROSWITCH

●	DENOTES CRITICAL CHARACTERISTICS.		
CPK	DENOTES CPK DIMENSIONS, -MINIMUM CPK VALUE		
(ST)	DENOTES A CHARACTERISTIC THAT PROVIDES AN INDICATION OF PROCESS PERFORMANCE. PROCEDURE FOR MEASUREMENT AND TRACKING TO BE DEFINED IN LITTELFUSE INSPECTION INSTRUCTIONS.		
CP	DENOTES CP DIMENSIONS, -MINIMUM CP VALUE MUST BE WITHIN THE DIMENSIONAL LIMITATIONS SHOWN ON DRAWING AND INITIALLY LOCATED TO ALLOW FOR MAXIMUM TOOL LIFE.		
MATL SPEC	FINISH		
DRW TVESELSK	DATE 11/6/2013	SCALE NTS	FINISH GOOD WT GRAMS/PIECE
UNLESS OTHERWISE SPECIFIED, DIMENSIONS ARE IN MILLIMETERS, DIMENSIONS IN BRACKETS [] ARE INCHES DIMENSIONING AND DO NOT INCLUDE PLATING. TOLERANCING TO BE INTERPRETED IN ACCORDANCE WITH ANSI Y14.5M-1994			
3RD ANGLE PROJECTION			
TITLE SQUARE BODY 71 CASE SIZE - METRIC THREAD OUTLINE			
		REVISION E	DRWG NO. OL-PSR071FL0000
CHICAGO, ILLINOIS 60631		SHEET 1 OF 1	

REVISION		
REV	DATE	DESCRIPTION
A	03/16/2016	517373GCP - RELEASED -TV
B	10/19/2017	518344ECP - REVISE STUD SIZE NOTES -TV
C	01/16/2018	518709ECP - CORRECT DIM -TV
D	8/30/18	519782ECP/D - CHG STUD TORQUE MRY
E	5/5/22	525161ECP/D - CHANGE HEIGHT, ADD TOLERANCES MRY
F	5/19/22	525232ECP/D - UPDATE LENGTH DIMENSION MRY

MOUNTING SPECS:
 STUD SIZE: M10x1.5-6H ∇ 11.5[0.45]
 STUD TORQUE: 26-35Nm

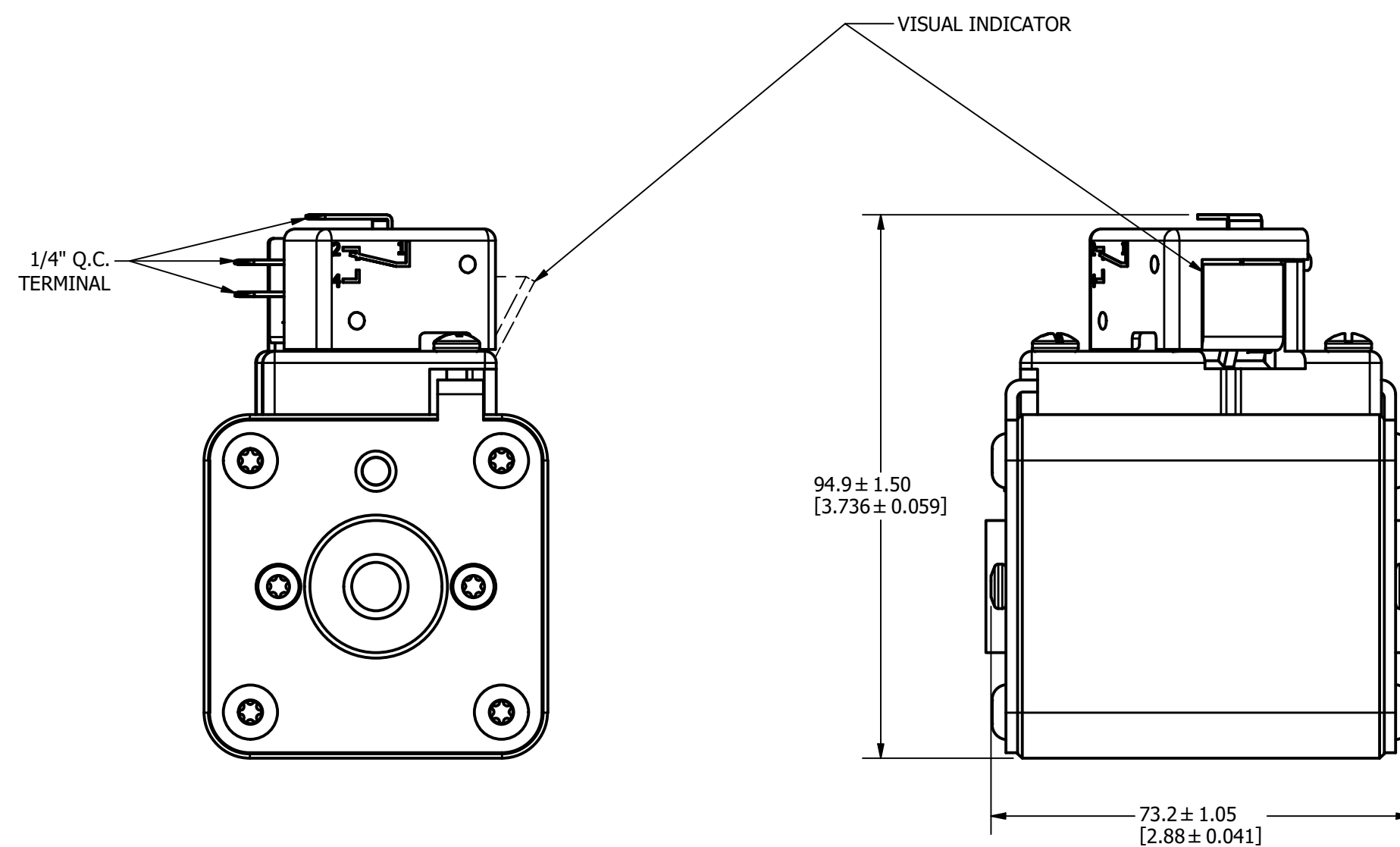
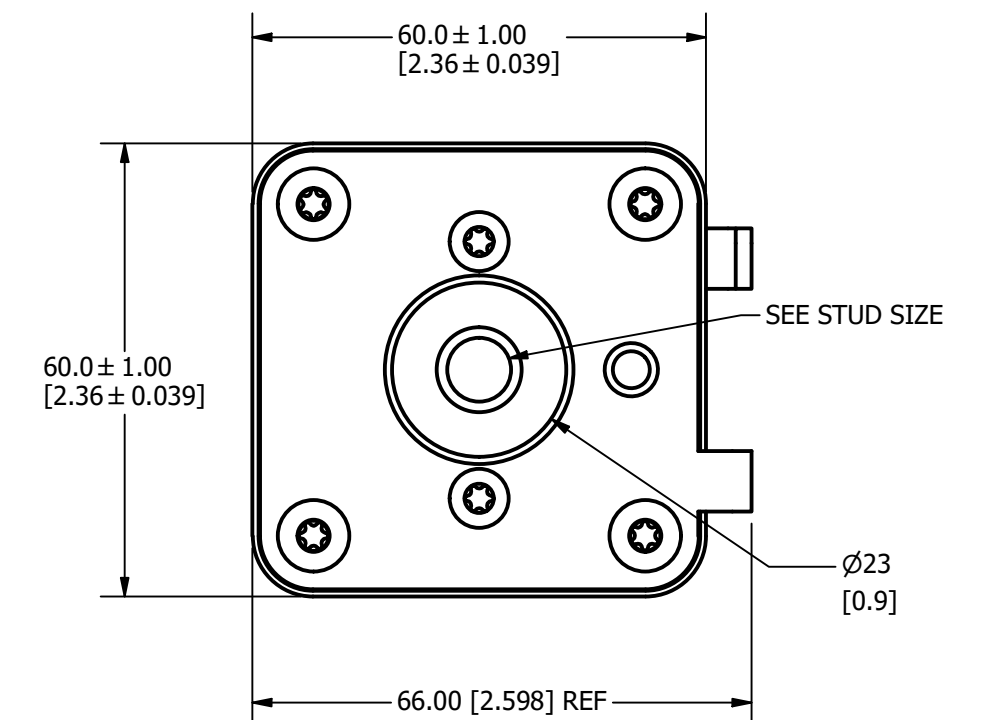
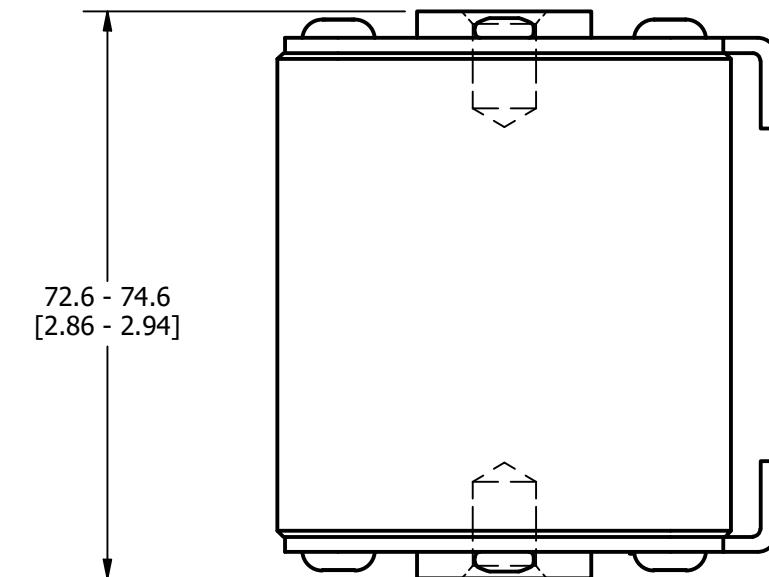
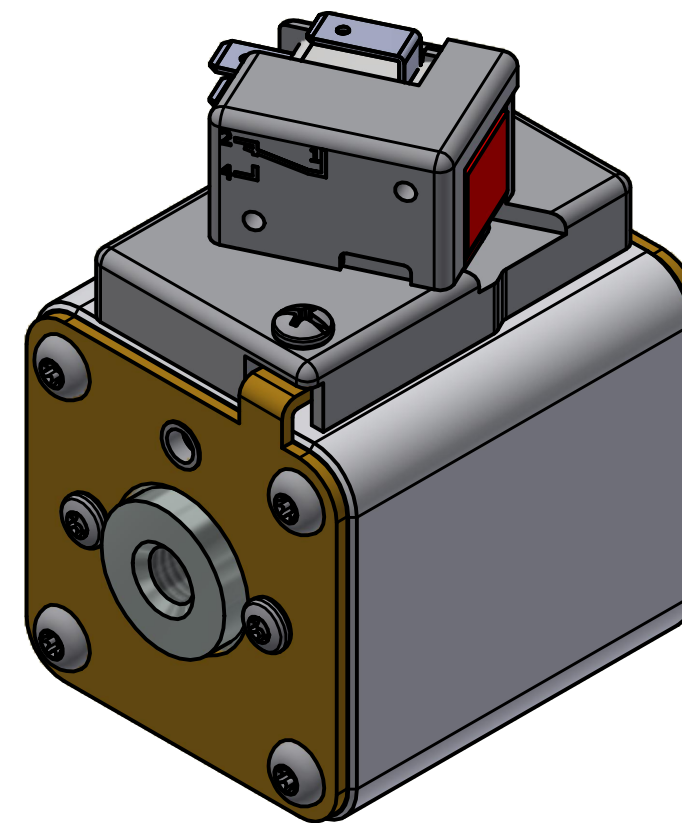
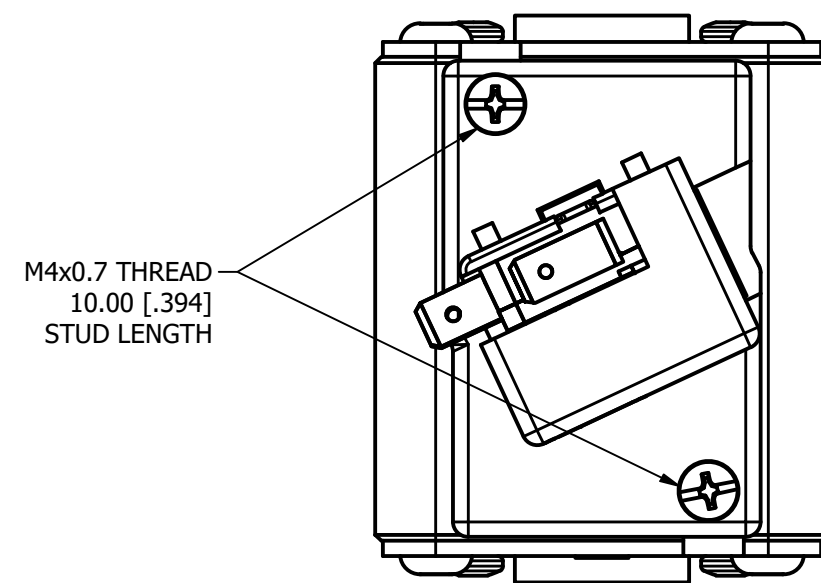

FUSE WITH MICROSWITCH

●	DENOTES CRITICAL CHARACTERISTICS.
CPK	DENOTES CPK DIMENSIONS, -MINIMUM CPK VALUE
(ST)	DENOTES A CHARACTERISTIC THAT PROVIDES AN INDICATION OF PROCESS PERFORMANCE. PROCEDURE FOR MEASUREMENT AND TRACKING TO BE DEFINED IN LITTELFUSE INSPECTION INSTRUCTIONS.
CP	DENOTES CP DIMENSIONS, -MINIMUM CP VALUE MUST BE WITHIN THE DIMENSIONAL LIMITATIONS SHOWN ON DRAWING AND INITIALLY LOCATED TO ALLOW FOR MAXIMUM TOOL LIFE.

MATL SPEC	FINISH		
DRW TVESELSK	DATE 2/15/2016	SCALE NTS	FINISH GOOD WT GRAMS/PIECE

UNLESS OTHERWISE SPECIFIED, DIMENSIONS ARE IN MILLIMETERS, DIMENSIONS IN BRACKETS [] ARE INCHES DIMENSIONING AND DO NOT INCLUDE PLATING. TOLERANCING TO BE INTERPRETED IN ACCORDANCE WITH ANSI Y14.5M-1994

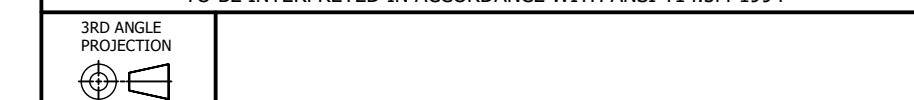

TITLE SQUARE BODY 72 CASE SIZE - METRIC THREAD OUTLINE

Littelfuse CHICAGO, ILLINOIS 60631	REVISION F	DRWG NO. OL-PSR072FL0000	SHEET 1 OF 1
--	---------------	-----------------------------	--------------

REVISION		DESCRIPTION
REV	DATE	
A	01/10/2018	518685GCP - RELEASED -TV
B	8/30/18	519782ECP/D - CHG STUD TORQUE MRY
C	5/5/22	525161ECP/D - CHANGE HEIGHT, ADD TOLERANCES MRY
D	5/19/22	525232ECP/D - UPDATE LENGTH DIMENSION MRY

MOUNTING SPECS:

STUD SIZE: M12x1.75-6H ∇ 13.0 [0.51]

STUD TORQUE: 45-55Nm

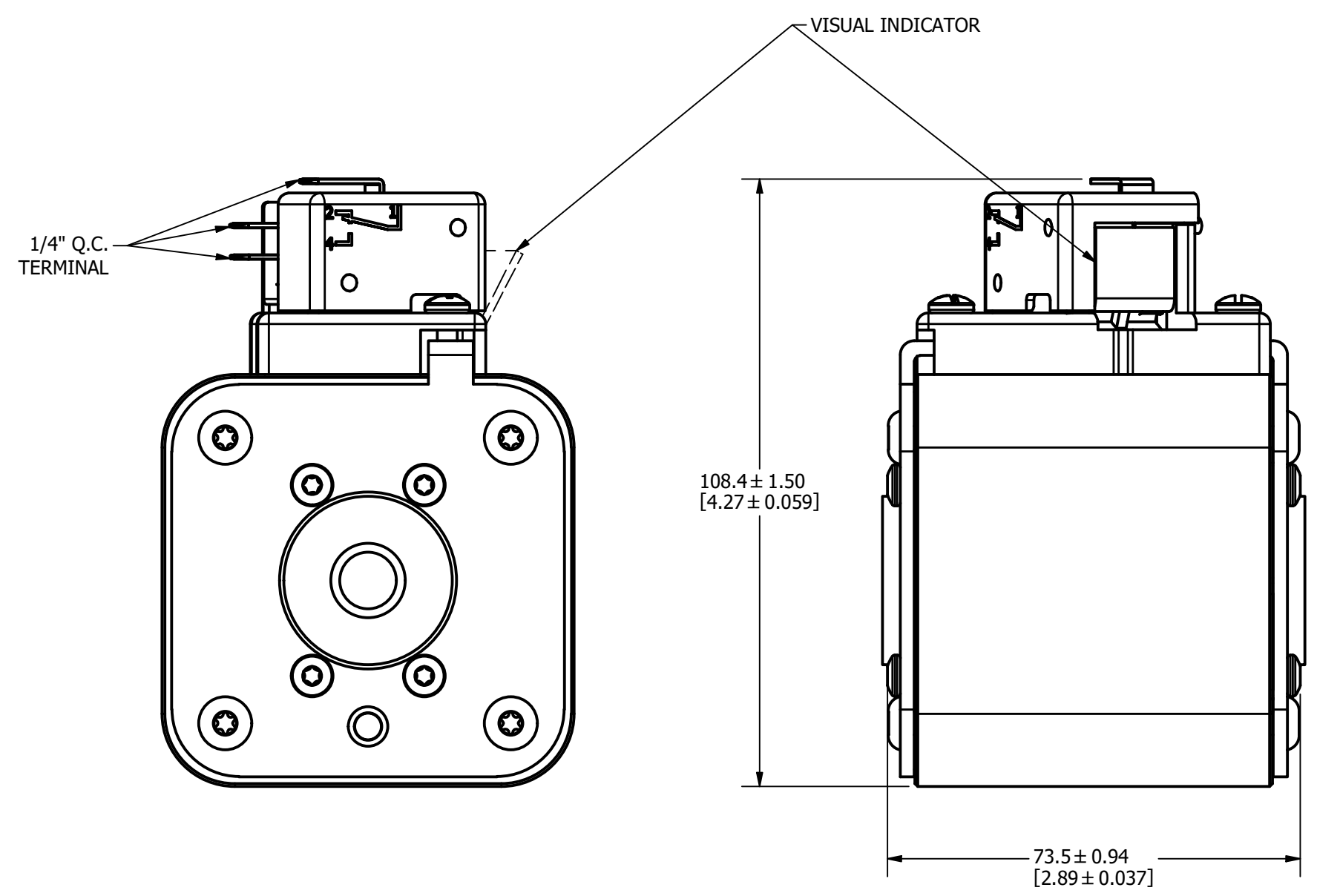
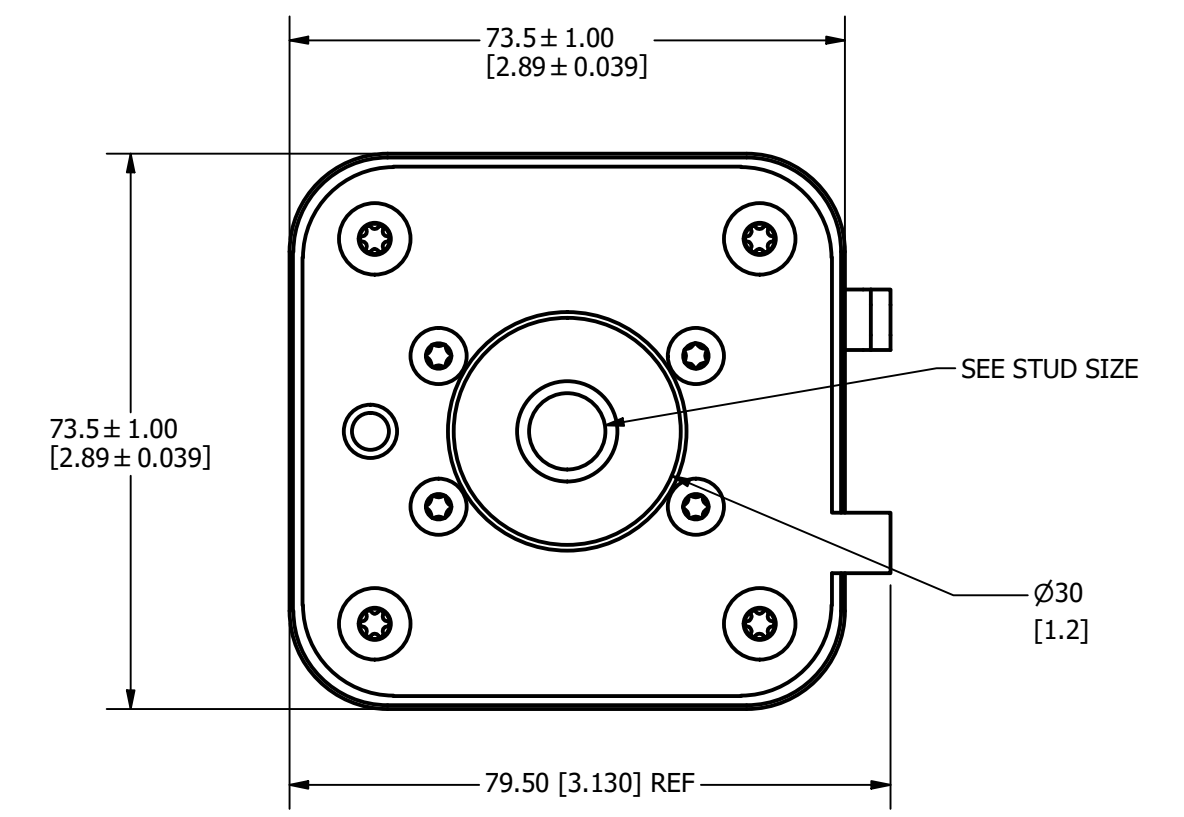
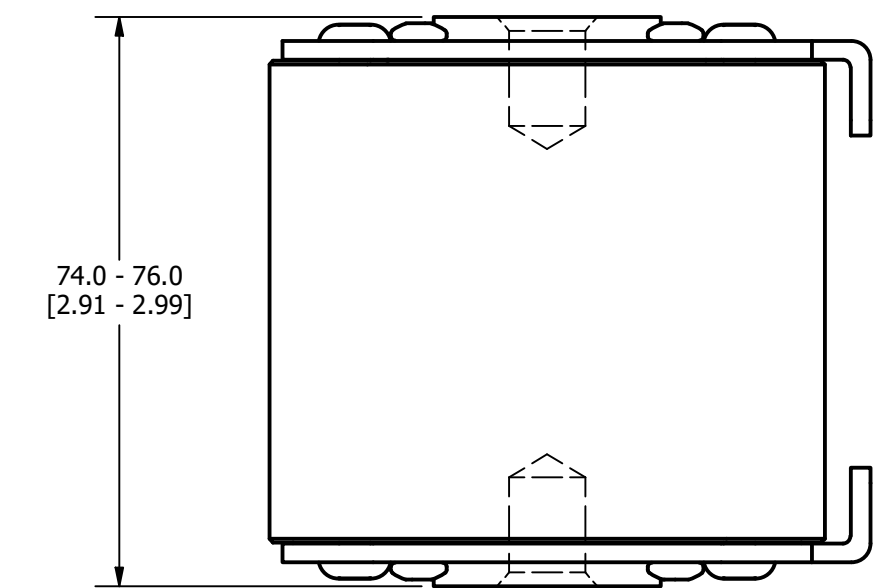
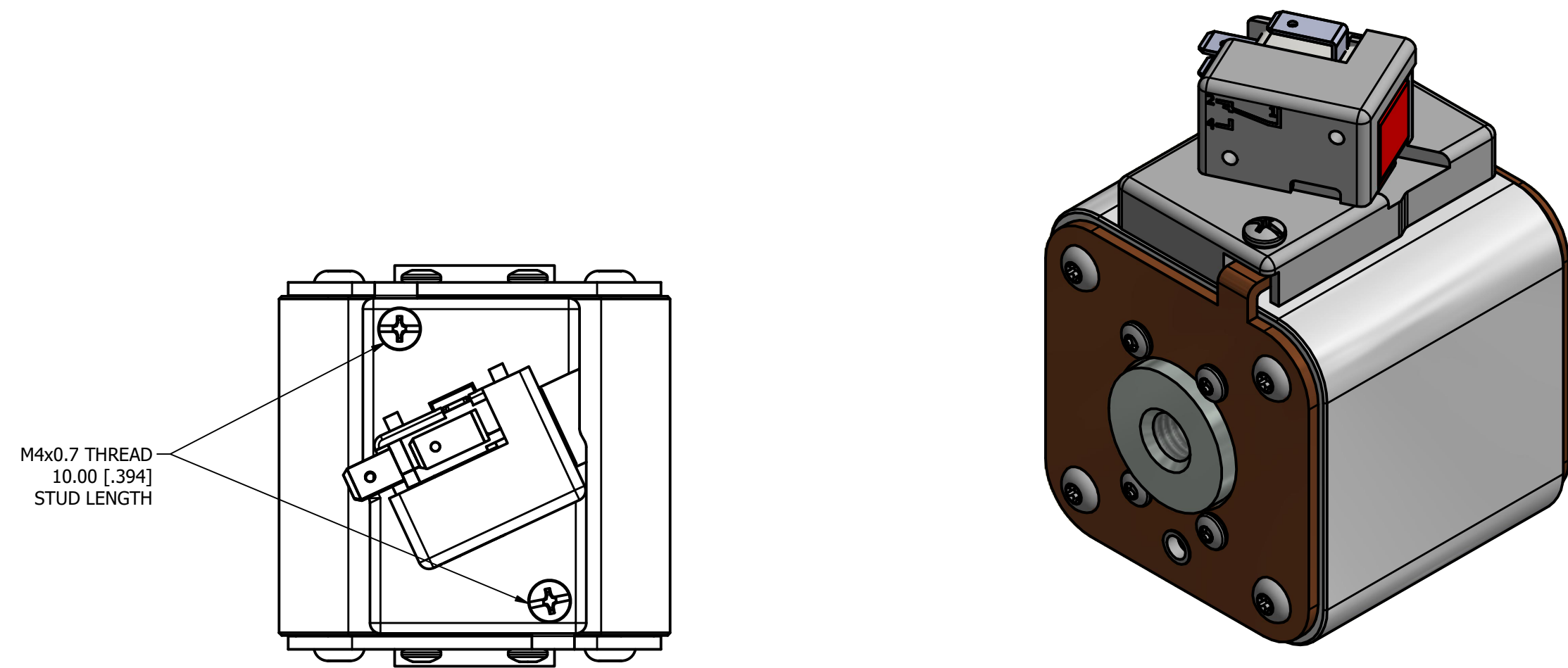

FUSE WITH MICROSWITCH

●	DENOTES CRITICAL CHARACTERISTICS.		
CPK	DENOTES CPK DIMENSIONS, -MINIMUM CPK VALUE		
(ST)	DENOTES A CHARACTERISTIC THAT PROVIDES AN INDICATION OF PROCESS PERFORMANCE. PROCEDURE FOR MEASUREMENT AND TRACKING TO BE DEFINED IN LITTELFUSE INSPECTION INSTRUCTIONS.		
CP	DENOTES CP DIMENSIONS, -MINIMUM CP VALUE MUST BE WITHIN THE DIMENSIONAL LIMITATIONS SHOWN ON DRAWING AND INITIALLY LOCATED TO ALLOW FOR MAXIMUM TOOL LIFE.		
MATL SPEC	FINISH		
DRW TVESELSK	DATE 2/4/2016	SCALE NTS	FINISH GOOD WT GRAMS/PIECE
UNLESS OTHERWISE SPECIFIED, DIMENSIONS ARE IN MILLIMETERS, DIMENSIONS IN BRACKETS [] ARE INCHES DIMENSIONING AND DO NOT INCLUDE PLATING. TOLERANCING TO BE INTERPRETED IN ACCORDANCE WITH ANSI Y14.5M-1994			
3RD ANGLE PROJECTION			
TITLE SQUARE BODY 73 CASE - METRIC THREAD OUTLINE			
		REVISION D	DRWG NO. OL-PSR073FL0000
CHICAGO, ILLINOIS 60631		SHEET 1 OF 1	