

REV	DATE	ECO	DESCRIPTION	BY	CK	APP
-	2-2-05	NA	INITIAL RELEASE	LDB	NA	NA

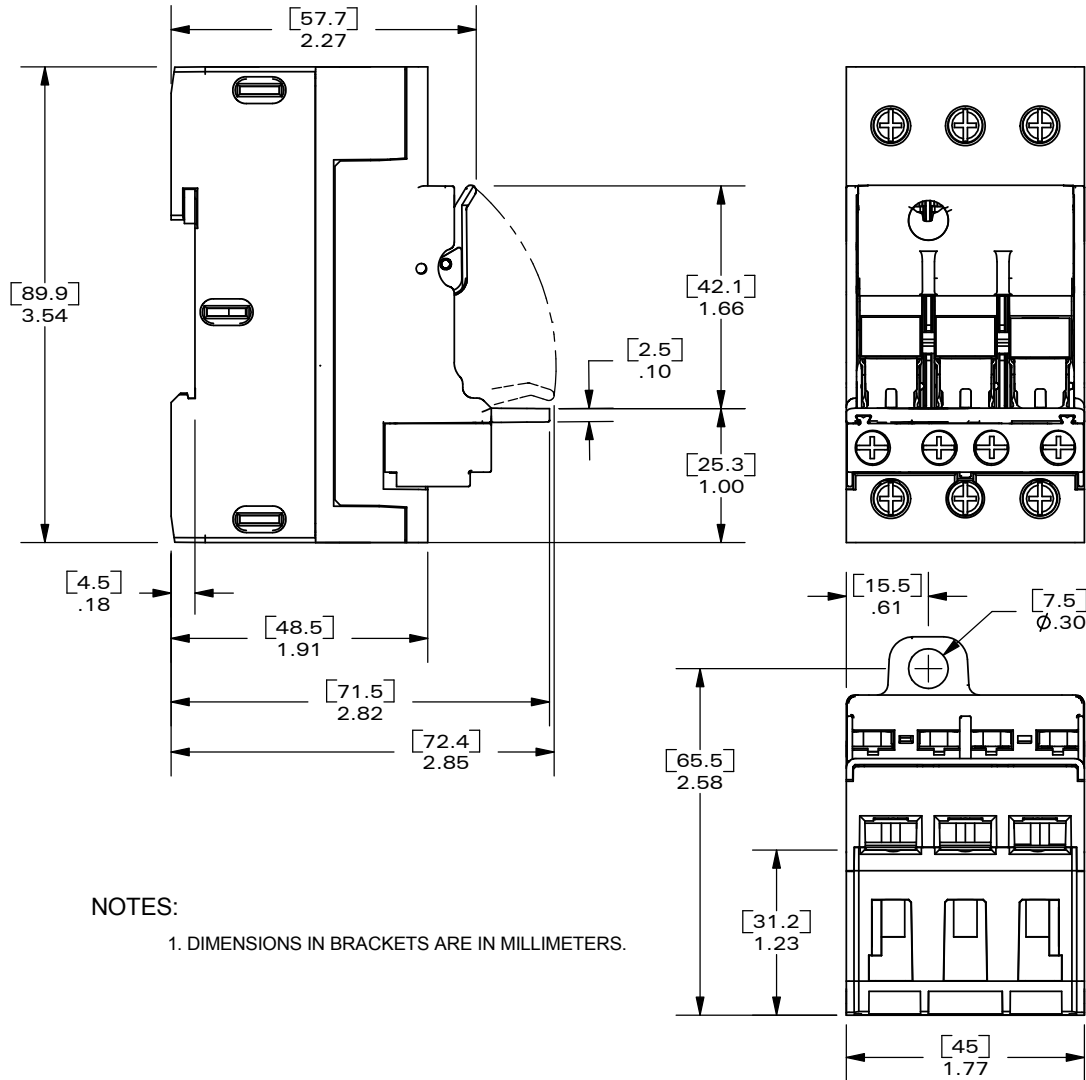

NOTES:

1. DIMENSIONS IN BRACKETS ARE IN MILLIMETERS.

P/N	CONN TYPE	RMS SYM RATING	TORQUE IN-LBS (N-M)	WIRE			U/L		CSA	
				WIRE RANGE	°C	TYPE	FILE NO.	GUIDE NO.	FILE	CLASS
USFMCCM USFMCCMI	PRESS. PLATE	200kA	15(1.7)	#10-#16AWG(1-4mm ²)	75	CU ONLY-SOL/STR	E52283	IZLT	32169	6225 01



FERRAZ SHAWMUT INC.
374 MERRIMAC STREET
NEWBURYPORT, MA 01950

PRODUCT MANAGER
SIGN:
DATE:

DESIGN ENGINEER
SIGN:
DATE:

ULTRASAFE FUSED MODULE
600V, 30A 3 POLE
CLASS CC W/AUX CONTACT

OUTLINE DIMENSIONS
NOT TO BE USED FOR PRODUCTION

701106