

# CFW320 VARIABLE SPEED DRIVE

Motors

**Automation**

Energy

Transmission and  
Distribution

Coatings

Compact size, high  
performance, ideal for  
industrial machines and  
processes in general



Driving efficiency and sustainability





**weg** CFW320  
VECTOR INVERTER

**weg** CFW  
VECTOR



WARNING  
ATTENTION  
ATENCIÓN  
ATENÇÃO  
警告

- REMOVE TERMINAL COVER ONLY 10 MIN. AFTER POWER HAS BEEN DISCONNECTED.
- READ THE INSTRUCTION MANUAL.
- ATTENDRE AU MOINS 10 MINUTES APRÈS AVOIR COUPÉ L'ALIMENTATION ÉLECTRIQUE AVANT D'OUVRIER LE BÔTIER DU TERMINAL.
- LIRE LE MANUAL D'UTILISATION.
- SOLAMENTE RETIRE LA TAPA FRONTAL LUEGO DE 10 MIN. DE DESENERGIZADO EL EQUIPO.
- VIRE MANUAL DE INSTRUCCIONES.
- SOMENTE REMOVA A TAMPÁ FRONTAL 10 MIN. APÓS A DESENERGIZAÇÃO.
- LEIA O MANUAL DE INSTRUÇÕES.
- 仅限切断电源10分钟以后打开此防护盖。
- 操作前请仔细阅读操作指导手册。



WARNING  
ATTENTION  
ATENCIÓN  
ATENÇÃO  
警告

- REMOVE TERMINAL COVER ONLY 10 MIN. AFTER POWER HAS BEEN DISCONNECTED.
- READ THE INSTRUCTION MANUAL.
- ATTENDRE AU MOINS 10 MINUTES APRÈS AVOIR COUPÉ L'ALIMENTATION ÉLECTRIQUE AVANT D'OUVRIER LE BÔTIER DU TERMINAL.
- LIRE LE MANUAL D'UTILISATION.
- SOLAMENTE RETIRE LA TAPA FRONTAL LUEGO DE 10 MIN. DE DESENERGIZADO EL EQUIPO.
- VIRE MANUAL DE INSTRUCCIONES.
- SOMENTE REMOVA A TAMPÁ FRONTAL 10 MIN. APÓS A DESENERGIZAÇÃO.
- LEIA O MANUAL DE INSTRUÇÕES.
- 仅限切断电源10分钟以后打开此防护盖。
- 操作前请仔细阅读操作指导手册。

# CFW320 - Variable Speed Drive

## Summary

Introduction	04
Flexibility	06
Connectivity	06
Applications	07
Easy to Use	08
Main Features	09
Coding	10
Specification	11
Accessories	13
Technical Data	15
Block Diagram	16

320  
R INVERTER

OVER ONLY 10 MIN. AFTER  
CONNECTED.  
IN MANUAL.  
0 MINUTES APRES AVOIR  
EN ÉLECTRIQUE AVANT  
DU TERMINAL.  
USATION.  
A TAPA FRONTAL LUEGO  
RGIZADO EL EQUIPO.  
RUCCKONES.  
AMPA FRONTAL 10 MIN.  
CAO.  
TRUCCIONES.  
种以用打 开此防 护盖  
操作指南手册。

# CFW320

The CFW320 is a **high-performance variable speed drive** for three-phase induction motors, ideal for applications on machines or equipment that require **precise control and easy operation**.

With a compact size, contactor-like installation, selectable WEG vector (V/VW) or scalar (V/F) control, built-in operating interface (HMI), SoftPLC, free WPS programming software and plug-in accessories to add functionalities, it is a **flexible solution with excellent cost-benefit**.

## CONVENIENCE ALL THE TIME

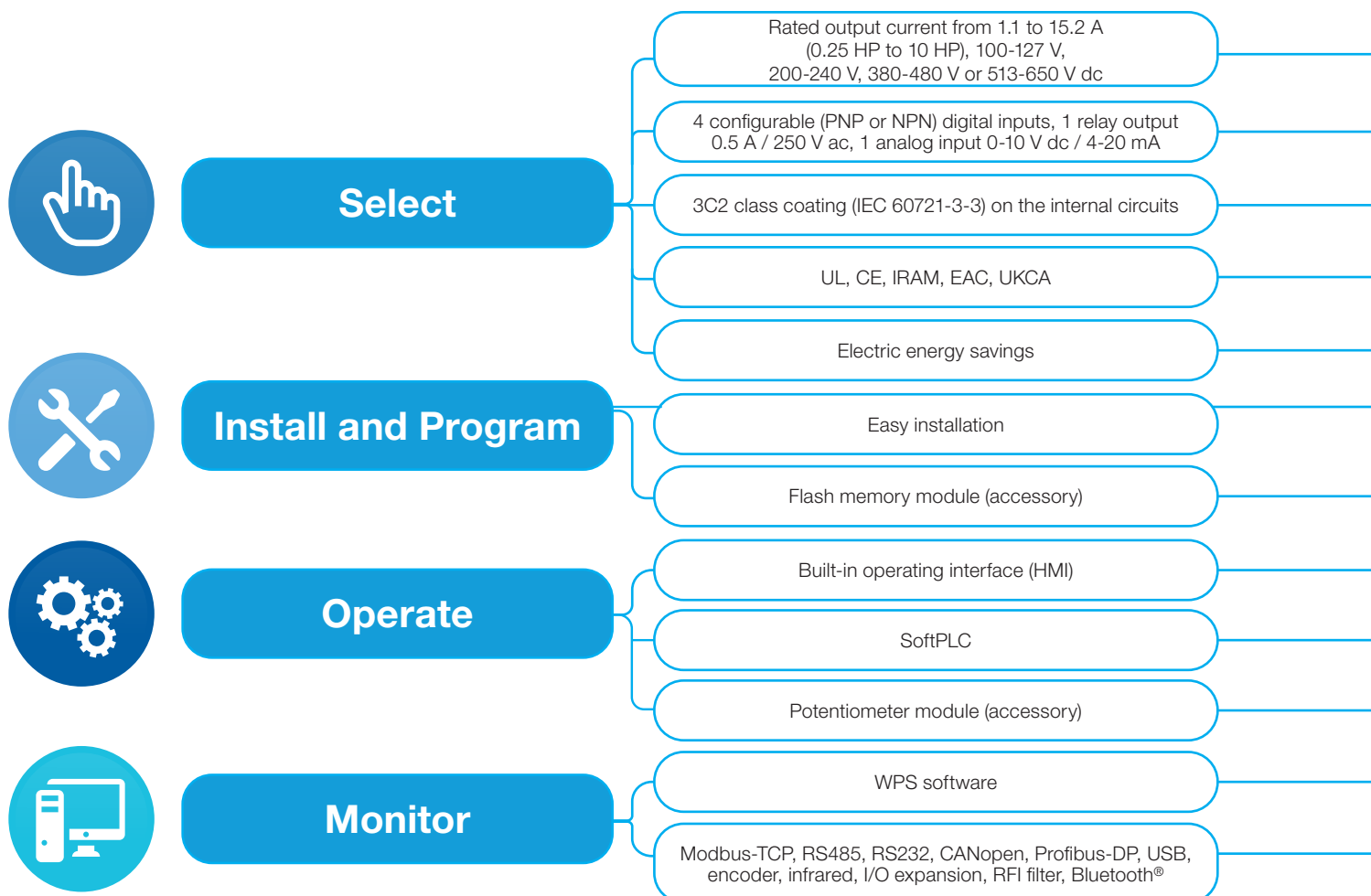



Single-phase, three-phase or DC-link power supply

Built-in inputs and outputs in the standard version

Greater protection for aggressive environments

Lead free, international certifications

High performance and efficiency

Power supply on top and output to the motor at the bottom

Used to copy the CFW320 original programming and download it to others with the VFDs turned off

The CFW320 status information is easily viewed on the screen

Built-in software equivalent to a small PLC

Used to vary the speed reference locally

Online monitoring, programming and configuration of the CFW320

Extra functionality expansion accessories

Ideal for machines or small devices

2 slots for function expansion through accessories

Available in the standard version at no additional cost

Green product, contributing to the conservation of the environment

Ideal for pumps and fans

Easy and intuitive installation with less wiring inside the electrical panel

Faster setting and configuration and quick start-up

Simple operation, configurable screen information, Remote operating interface (accessory)

Customization and integration of the CFW320 to different applications

Easiness to machine builders

Easy and intuitive environment, free software

Flexibility, according to the application requirements

## Flexibility

### Flash Memory Module (MMF-uDrives Accessory)

It downloads the original parameter setting to several CFW320 variable speed drives turned off.



### 2 Slots for Function Expansion with Accessories

Slots for accessibility and network communication module

Slots for input and output (I/O) expansion module



### Fan Easily Removable

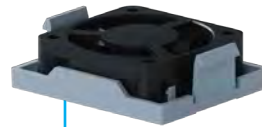

### RFI Filter (Accessory CFW320 - KFA / B / C)

Category C2 or C3 to reduce the electromagnetic interference emission level

### Greater Protection for Aggressive Environments

Standard coating classified as 3C2 according to IEC 60721-3-3 on all versions, ensuring greater protection to the internal circuits against corrosive atmospheres.



## Connectivity

### Bluetooth®

(not available in the US)



## Applications



## Easy to Use

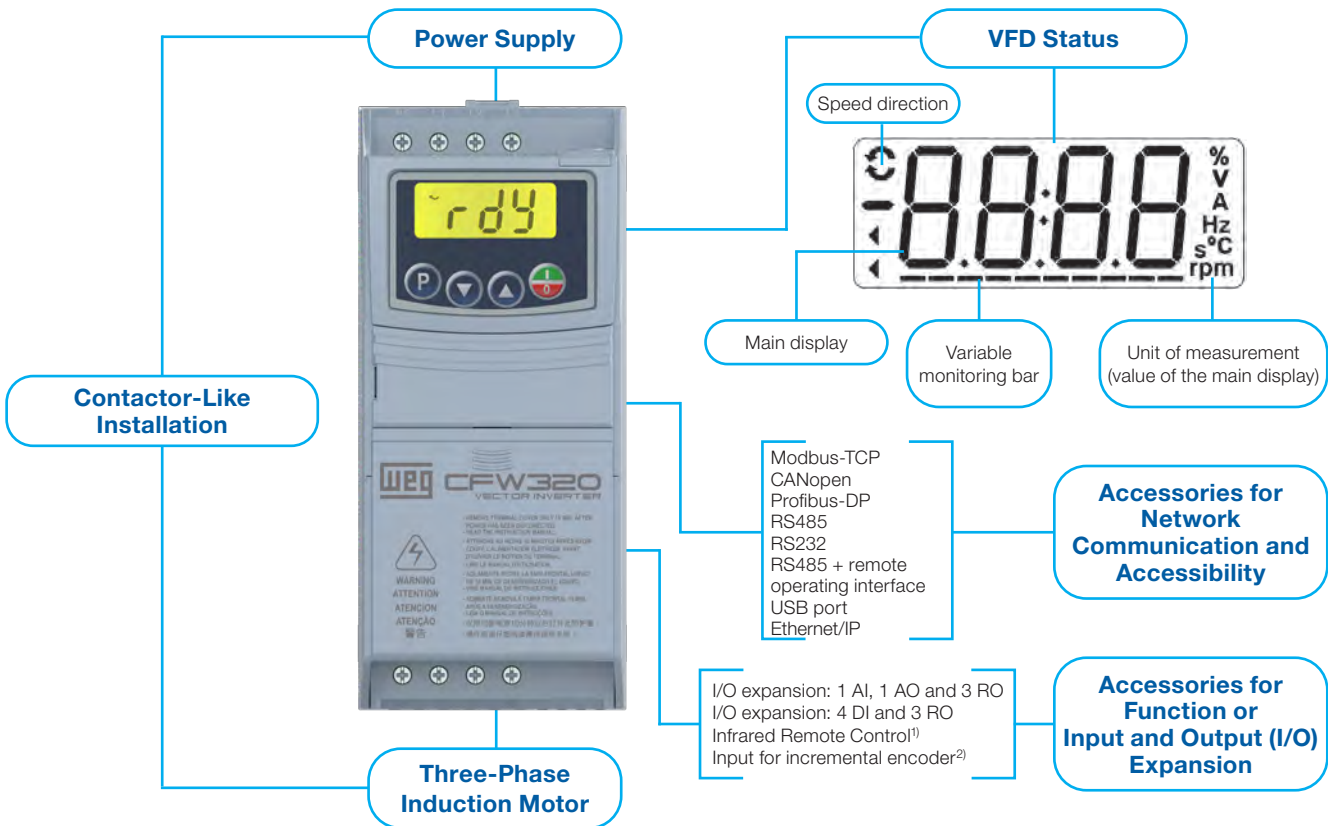

Notes: I/O = Inputs and Outputs; AI = Analog Input, AO = Analog Output, RO = Relay Output, DI = Digital Input.

1) Included in the CFW320-IOADR accessory.

2) Included in the CFW320-IOAENC accessory.

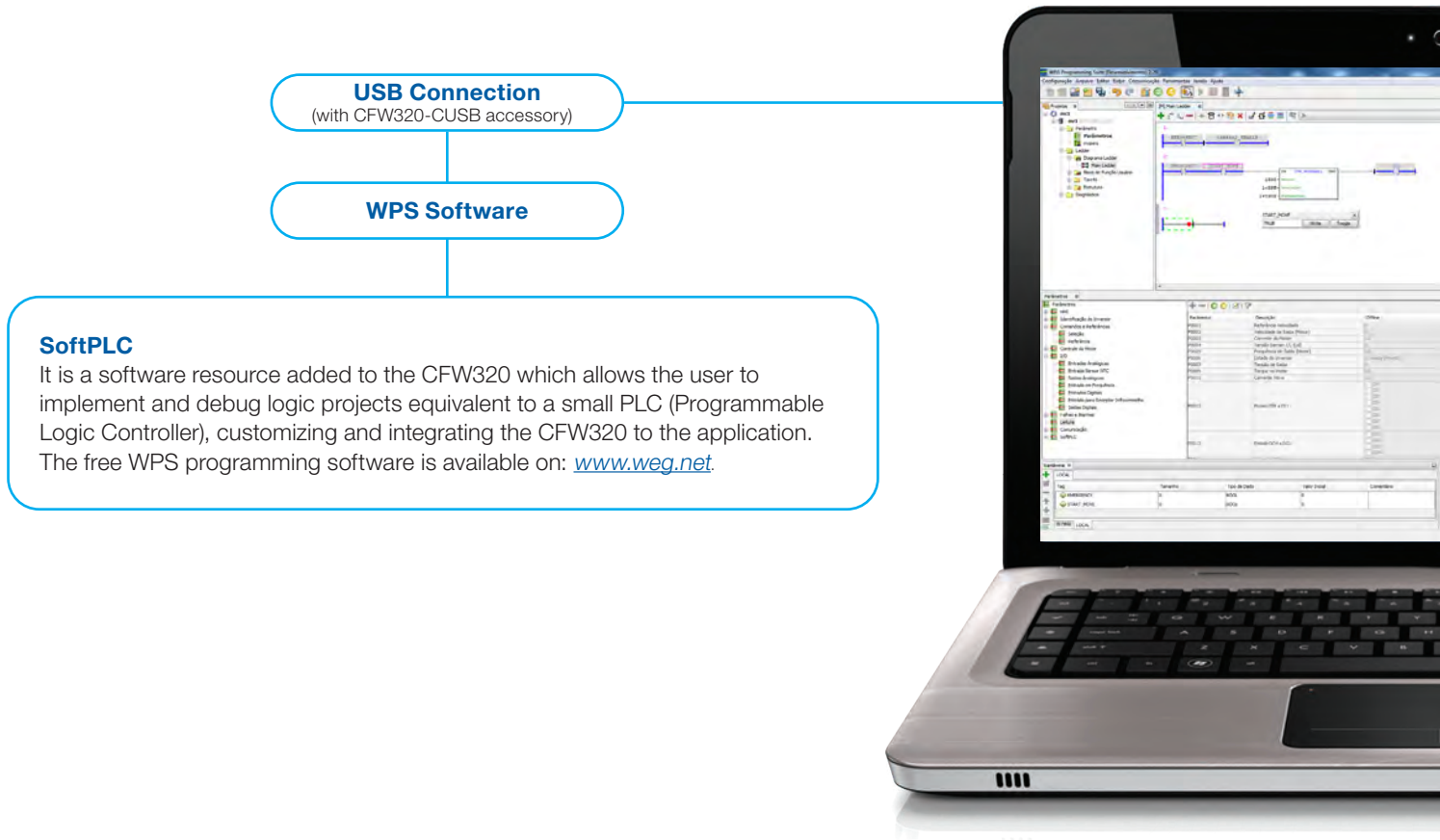

## Main Features

- Selectable V/F, quadratic V/F or VVW vector control
- Password to protect the setting
- Special engineering units (V, A, Hz, rpm, s, °C, %)
- Backup of all parameters (via WPS software, memory card or internal memory of the CFW320)
- Setting of the switching frequency according to the application requirements
- Speed reference via electronic potentiometer (EP)
- Speed reference via frequency input signal
- Multispeed with up to eight programmable speeds
- Slip compensation
- Manual or automatic torque boost (V/F scalar mode) or self-adjustment (VVW vector mode)
- 2 acceleration/deceleration ramps and emergency deceleration ramp
- "S" type ramp
- DC braking
- Internal dynamic braking (frame sizes B and C)
- Infrared control (via CFW320-IOAR accessory)
- PID controller to control processes in closed loop (via WPS)
- Flying start / ride through
- Skip frequency or frequency ranges
- Overload and overtemperature protection on the motor and IGBTs
- Overcurrent protection
- DC link voltage supervision
- Self-diagnosis alarm
- Fault log
- SoftPLC programming via free WPS software
- Fan control
- Energy Saving function
- Fire Mode function
- Modbus Master function

# Many More

## Many more advantages

The CFW320 replaces direct online starters or star-delta starters:

- Electric energy savings
- Precise speed control
- Protection and increased useful life of the electric motor
- Fault log and diagnostics
- Easy operation and installation
- Flexible, allowing the installation of accessories in the application (Plug & Play)

Easy and friendly environment

Free on the website [www.weg.net](http://www.weg.net)

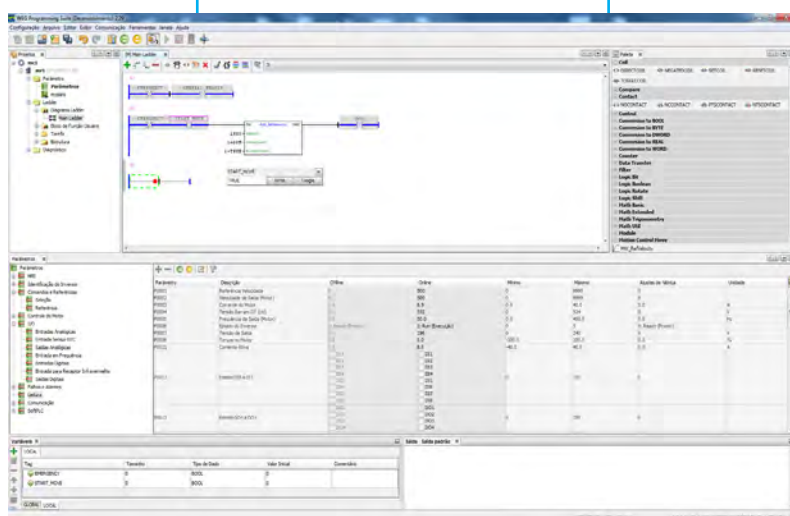

## Coding

Inverter / smart code	Model identification				Internal dynamic braking (IGBT)	Protection degree	Hardware version	Software version
	Size	Rated output current	Number of phases	Rated voltage				
CFW320	A	01P6	S	2	NB	20		
	See availability in the following table							
	NB = without dynamic braking (IGBT)							
	DB = with dynamic braking (IGBT)							
	20 = IP20							
	Hx = special hardware							
Sx = special software								

Note: for versions with special hardware (Hx) and software (Sx), contact WEG Automation's sales department or your sales representative.

### Available Options

Size	Rated output current	Number of phases	Rated voltage	Braking
A	01P6 = 1.6 A	S = single-phase power supply	1 = 110-127 V ac	NB
	02P6 = 2.6 A			
	04P2 = 4.2 A			
	06P0 = 6.0 A			
	01P6 = 1.6 A			
	02P6 = 2.6 A			
	04P2 = 4.2 A	T = three-phase power supply	2 = 200-240 V ac	
	06P0 = 6.0 A			
	07P3 = 7.3 A			
	01P6 = 1.6 A			
	02P6 = 2.6 A			
	04P2 = 4.2 A			
	06P0 = 6.0 A	D = DC power supply	3 = 280-340 V dc	
	07P3 = 7.3 A			
	01P6 = 1.6 A			
02P6 = 2.6 A				
04P2 = 4.2 A				
06P0 = 6.0 A				
07P3 = 7.3 A	B = single-phase, three-phase or DC power supply	2 = 200-240 V ac or 280-340 V dc		
10P0 = 10.0 A				
B	15P2 = 15.2 A	T = three-phase or DC power supply		
A	01P1 = 1.1 A	T = three-phase power supply	4 = 380-480 V ac	NB
	01P8 = 1.8 A			
	02P6 = 2.6 A			
	03P5 = 3.5 A			
04P8 = 4.8 A	T = three-phase or DC power supply	4 = 380-480 V ac or 513-650 V dc		
B			05P6 = 5.6 A	
C			07P6 = 7.6 A	
			08P3 = 8.3 A	
			11P0 = 11.0 A	
B			14P0 = 14.0 A	
			01P1 = 1.1 A	
			01P8 = 1.8 A	
			02P6 = 2.6 A	
			03P5 = 3.5 A	
	04P8 = 4.8 A			
C	05P6 = 5.6 A			
	07P6 = 7.6 A			
	08P3 = 8.3 A			
	11P0 = 11.0 A			
C	14P0 = 14.0 A			DB

# Specification

## AC Power Supply

Reference	CFW320 variable speed drive <sup>2)</sup>				Maximum applicable motor <sup>1)</sup>			
	Power supply (V)	Frame	Braking IGBT	Rated output current (A)	Power supply (V)	HP		
CFW320A01P6S1NB20	110-127	Single-phase	A	1.6	230	1/4 or 1/3		
CFW320A02P6S1NB20				2.6		3/4		
CFW320A04P2S1NB20				4.2		1		
CFW320A06P0S1NB20				6.0		2		
CFW320A01P6S2NB20	200-240	Single-phase	A	1.6		1/4 or 1/3		
CFW320A02P6S2NB20				2.6		3/4		
CFW320A04P2S2NB20				4.2		1		
CFW320A06P0S2NB20				6.0		2		
CFW320A07P3S2NB20				7.3		2		
CFW320B10P0B2DB20	200-240	Single-phase or Three-phase	B	Internal included		10.0	3	
CFW320A01P6T2NB20		A	Not available	1.6		1/4 or 1/3		
CFW320A02P6T2NB20				2.6		3/4		
CFW320A04P2T2NB20				4.2		1		
CFW320A06P0T2NB20				6.0		2		
CFW320A07P3T2NB20				7.3		2		
CFW320B10P0B2DB20		B	Internal included	10.0		3		
CFW320B15P2T2DB20				15.2	5			
CFW320A01P1T4NB20				380-415	A	Not available	1.1	0.5
CFW320A01P8T4NB20							1.8	1
CFW320A02P6T4NB20	2.6						1.5	
CFW320A03P5T4NB20	3.5	2						
CFW320A04P8T4NB20	4.8	3						
CFW320B05P6T4NB20	B	6.5	3					
CFW320B07P6T4NB20		8.2	5					
CFW320C08P3T4NB20	C	10.0	5					
CFW320C11P0T4NB20		12.0	7.5					
CFW320C14P0T4NB20	15.0	10						
CFW320B01P1T4DB20	380-415	Three-phase	B		Internal included	1.1	0.5	
CFW320B01P8T4DB20						1.8	1	
CFW320B02P6T4DB20						2.6	1.5	
CFW320B03P5T4DB20						3.5	2	
CFW320B04P8T4DB20						4.8	3	
CFW320B05P6T4DB20						6.5	3	
CFW320B07P6T4DB20				8.2		5		
CFW320C08P3T4DB20				C		10.0	5	
CFW320C11P0T4DB20			12.0		7.5			
CFW320C14P0T4DB20			15.0	10				
CFW320A01P1T4NB20			440-480	A	Not available	1.1	0.5	
CFW320A01P8T4NB20						1.8	1	
CFW320A02P6T4NB20						2.6	1.5	
CFW320A03P5T4NB20						3.5	2	
CFW320A04P8T4NB20						4.8	3	
CFW320B05P6T4NB20						B	5.6	3
CFW320B07P6T4NB20	7.6	5						
CFW320C08P3T4NB20	C	8.3				5		
CFW320C11P0T4NB20		11.0		7.5				
CFW320C14P0T4NB20	14.0	10						
CFW320B01P1T4DB20	440-480	Three-phase		B	Internal included	1.1	0.5	
CFW320B01P8T4DB20						1.8	1	
CFW320B02P6T4DB20						2.6	1.5	
CFW320B03P5T4DB20						3.5	2	
CFW320B04P8T4DB20						4.8	3	
CFW320B05P6T4DB20						5.6	3	
CFW320B07P6T4DB20			7.6			5		
CFW320C08P3T4DB20			C			8.3	5	
CFW320C11P0T4DB20				11.0	7.5			
CFW320C14P0T4DB20			14.0	10				

Notes: 1) The power values for the maximum applicable motor shown in the table above are reference values and valid for WEG three-phase, four-pole induction motors with power supply of 230 V, 380 V or 460 V. The proper sizing of the CFW320 to be used must be determined as a function of the rated current of the motor used.

2) Designed for exclusive industrial or professional use.

# Specification

## DC Power Supply

Reference	CFW320 variable speed drive <sup>2)</sup>				Maximum applicable motor <sup>1)</sup>			
	Power supply (V)	Frame	Braking IGBT	Rated output current (A)	Power supply (V)	HP		
CFW320A01P6D3NB20 <sup>3)</sup>	DC link (280-340 V dc)	A	Not available	1.6	230	1/4 or 1/3		
CFW320A02P6D3NB20 <sup>3)</sup>		A		2.6		3/4		
CFW320A04P2D3NB20 <sup>3)</sup>		A		4.2		1		
CFW320A06P0D3NB20 <sup>3)</sup>		A		6.0		2		
CFW320A07P3D3NB20 <sup>3)</sup>		A		7.3		2		
CFW320B10P0B2DB20		B	Internal included	10.0		3		
CFW320B15P2T2DB20		B		15.2		5		
CFW320B05P6T4NB20	DC link (513-560 V dc)	B	Not available	6.5	380	3		
CFW320B07P6T4NB20		B		8.2		5		
CFW320C08P3T4NB20		C		10.0		5		
CFW320C11P0T4NB20		C	12.0	7.5				
CFW320C14P0T4NB20		C	15.0	10				
CFW320B01P1T4DB20		B	Internal included	1.1		0.5		
CFW320B01P8T4DB20		B		1.8		1		
CFW320B02P6T4DB20		B		2.6		1.5		
CFW320B03P5T4DB20		B		3.5		2		
CFW320B04P8T4DB20		B		4.8		3		
CFW320B05P6T4DB20		B		6.5		3		
CFW320B07P6T4DB20		B		8.2		5		
CFW320C08P3T4DB20		C		10.0		5		
CFW320C11P0T4DB20		C		12.0		7.5		
CFW320C14P0T4DB20		C		15.0		10		
CFW320B05P6T4NB20		DC link (594-650 V dc)	B	Not available		5.6	460	3
CFW320B07P6T4NB20			B			7.6		5
CFW320C08P3T4NB20			C			8.3		5
CFW320C11P0T4NB20			C			11.0		7.5
CFW320C14P0T4NB20			C			14.0		10
CFW320B01P1T4DB20	B		Internal included	1.1	0.5			
CFW320B01P8T4DB20	B			1.8	1			
CFW320B02P6T4DB20	B			2.6	1.5			
CFW320B03P5T4DB20	B			3.5	2			
CFW320B04P8T4DB20	B			4.8	3			
CFW320B05P6T4DB20	B			5.6	3			
CFW320B07P6T4DB20	B			7.6	5			
CFW320C08P3T4DB20	C			8.3	5			
CFW320C11P0T4DB20	C			11.0	7.5			
CFW320C14P0T4DB20	C			14.0	10			

















Notes: 1) The power values for the maximum applicable motor shown in the table above are reference values and valid for WEG three-phase, four-pole induction motors with power supply of 220 V, 380 V or 440 V. The proper sizing of the CFW320 to be used must be determined as a function of the rated current of the motor used.

2) Designed for exclusive industrial or professional use.

3) Non-Stock item. Please contact WEG for availability.

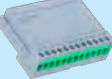
## Accessories

The CFW320 has inputs and outputs in the standard version and allows installing Plug & Play accessories, which makes it flexible and increases its capacity to adapt to the requirements of different applications. In the front part there are two independent slots: the upper slot, which can be used to add network communication or accessibility, and the lower slot, which can be used for input and output (I/O) expansion, incremental encoder input or infrared remote control kit.

Reference	Description	Illustrative figures
<b>Upper slot - network communication and accessibility</b>		
CFW320-CRS485	RS485 communication module	
CFW320-CUSB	USB communication module (with 2 m cable)	
CFW320-CRS232	RS232 communication module	
CFW320-CCAN	CANopen or DeviceNet communication module	
CFW320-CPDP	Profibus-DP communication module	
CFW320-IOP	Reference module via potentiometer	
CFW320-CETH	Ethernet/IP or Modbus TCP Communication Module	
CFW320-CBLT <sup>3)</sup>	Communication module	
<b>Lower slot - input and output (I/O) expansion</b>		
CFW320-IOAR	1 analog input, 1 analog output and 3 relay outputs	
CFW320-IODR	4 digital inputs and 3 relay outputs	
CFW320-IOAENC	1 analog input, 2 analog outputs and 1 incremental encoder input	
CFW320-IOADR	1 NTC input, 3 relay outputs and 1 input for infrared sensor (infrared sensor, NTC and remote control with battery included)	
CFW320-IODF	Multipump application: 3 digital inputs in frequency, 3 digital outputs in frequency	
<b>Remote operating interface (HMI)</b>		
CFW320-KHMIR	Kit with remote HMI (CFW300-CRS485 + 3 m cable included)	
<b>Flash memory</b>		
MMF-uDrives	Flash memory module (1 m cable included)	
<b>RFI filter<sup>4)</sup></b>		
CFW300-CFW320-KFA-S1-S2	RFI filter kit CFW320 frame A single-phase (200 V line) <sup>1)</sup>	
CFW300-CFW320-KFB-S2	RFI filter kit CFW320 frame B single-phase (200 V line) <sup>1)</sup>	
CFW320-KFA-T2	RFI filter kit CFW320 frame A three-phase (200 V line) <sup>1)</sup>	
CFW320-KFB-T2	RFI filter kit CFW320 frame B three-phase (200 V line) <sup>1)</sup>	
CFW320-KFA-T4	RFI filter kit CFW320 frame A three-phase (400 V line) <sup>2)</sup>	
CFW320-KFB-T4	RFI filter kit CFW320 frame B three-phase (400 V line) <sup>2)</sup>	
CFW320-KFC-T4	RFI filter kit CFW320 frame C three-phase (400 V line) <sup>2)</sup>	

Notes: 1) The filter kit is supplied with the following components: RFI filter and connection bars.

2) The filter kit is supplied with the following components: RFI filter, connection bars and common-mode choke.

3) Not available in the US.

4) The RFI filters are not "UL" Listed.

## Specification

### Configuration of the Plug-In Modules<sup>6)</sup>

Reference	Slots <sup>5)</sup>	Inputs			Outputs			Potentiometer for speed reference	USB <sup>4)</sup>	Infrared sensors and NTC <sup>3)</sup>	Bluetooth <sup>®</sup>	Encoder input <sup>2)</sup>	Network communication		
		Analog	Digital	Frequency	Analog	Relay digital	Frequency						RS485	RS232	Others
CFW320-CRS485	Upper slot	-	-	-	-	-	-	-	-	-	-	-	1	-	-
CFW320-CRS232		-	-	-	-	-	-	-	-	-	-	-	-	1	-
CFW320-CCAN		-	-	-	-	-	-	-	-	-	-	-	-	-	CANopen or DeviceNet
CFW320-CPDP		-	-	-	-	-	-	-	-	-	-	-	-	-	Profibus-DP
CFW320-CUSB		-	-	-	-	-	-	-	1	-	-	-	-	-	-
CFW320-IOP		-	-	-	-	-	-	-	1	-	-	-	-	-	-
CFW320-CETH		-	-	-	-	-	-	-	-	-	-	-	-	-	Ethernet/IP or Modbus TCP
CFW320-CBLT <sup>7)</sup>		-	-	-	-	-	-	-	-	-	1	-	-	-	-
CFW320-IOAR	Lower slot	1	-	-	1	3	-	-	-	-	-	-	-	-	
CFW320-IODR <sup>1)</sup>		-	4	-	-	3	-	-	-	-	-	-	-	-	
CFW320-IOAENC		1	-	-	2	-	-	-	-	-	-	1	-	-	
CFW320-IOADR		1	-	-	-	3	-	-	-	1	-	-	-	-	
CFW320-IOADR-D		-	-	-	-	3	-	-	-	1	-	-	-	-	
CFW320-IODF		-	-	3	-	-	3	-	-	-	-	-	-	-	-

Notes: 1) Configurable isolated digital inputs (NPN or PNP).

2) Incremental Encoder (A/A - B/B), power supply of +5 V @ 100 mA for the encoder, maximum frequency of 400 kHz.

3) Remote control and battery included.

4) USB cable included.

5) It allows 1 plug-in module in the upper slot (network communication or accessibility) and 1 plug-in module in the lower slot (input/output expansion).

6) The standard version of the CFW320 already has 4 (configurable) PNP or NPN digital inputs, 1 analog input 0-10 V dc / 4-20 mA and 1 relay output 0.5 A / 250 V ac.

7) Not available in US.

### Dimensions

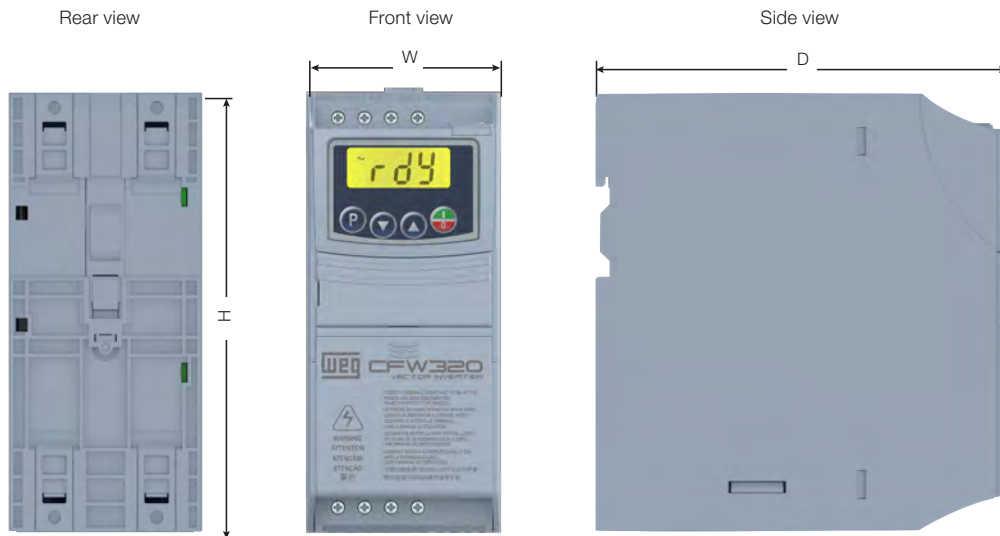

#### Dimensions without RFI Filter

Size	H mm (in)	W mm (in)	D mm (in)	Weight kg (Lb)
A	157.9 (6.22)	70.0 (2.76)	148.4 (5.84)	0.90 (1.98)
B	198.9 (8.08)	70.0 (2.76)	158.4 (6.24)	1.34 (2.95)
C	214.0 (8.43)	89.0 (3.50)	164.0 (6.45)	1.50 (3.30)

Note: tolerance of the dimensions: ±1.0 mm (±0.039 in).

#### Dimensions with RFI Filter

Size	H mm (in)	W mm (in)	D mm (in)	Weight kg (Lb)
A	196.0 (7.72)	70.0 (2.76)	190.1 (7.48)	1.30 (2.86)
B	237.0 (9.33)	70.0 (2.76)	200.1 (7.88)	1.80 (3.96)
C	252.3 (9.93)	89.0 (3.50)	207.5 (8.17)	1.96 (4.31)

Note: tolerance of the dimensions: ±1.0 mm (±0.039 in).

## Technical Data

<b>Power data</b>	Power supply	<p>Voltage tolerance: -15% to +10% of the rated voltage</p> <p>Frequency: 50/60 Hz (48 Hz to 62 Hz)</p> <p>Phase imbalance: <math>\leq 3\%</math> of the rated phase-phase input voltage</p> <p>Overtoltage according to category III (EM 61010/UL 508C)</p> <p>Transient voltages according to category III</p> <p>Maximum of 10 connections per hour (1 every 6 minutes)</p> <p>Typical efficiency: <math>\geq 97\%</math></p> <p>Classification of chemically active substances: level 3C2.</p> <p>Classification of mechanical conditions (vibration): level 3M4.</p> <p>Audible noise level: <math>&lt; 60</math> dB</p>
<b>Installation and connection</b>	Environment conditions permitted for operation	<p>Temperature around the VFD: from 0 °C to 50 °C (200 V line) and from 0 °C to 40 °C (400 V line)</p> <p>For higher temperatures than the specifications above, it is necessary to apply 2% of current derating for each Celcius degree, limited to an increase of 10 °C</p> <p>Air relative humidity: 5% to 95% non-condensing.</p> <p>Maximum altitude: up to 1,000 m - rated conditions</p> <p>1,000 m to 4,000 m - 1% current derating for each 100 m above 1,000 m.</p> <p>From 2,000 m to 4,000 m above sea level – maximum voltage derating (127 V / 240 V / 480 V, according to the model) of 1.1% for each 100 m above 2,000 m</p> <p>Pollution degree: 2 (according to EN 50178 and UL 508C), with non-conductive pollution. Condensation must not cause conduction of the accumulated residues</p>
<b>Control</b>	Method	<ul style="list-style-type: none"> <li>- V/F (scalar)</li> <li>- V/F (quadratic)</li> <li>- VVV: voltage vector control</li> <li>- PWM SVM (Space Vector Modulation)</li> </ul>
	Output frequency	0 to 400 Hz, resolution of 0.1 Hz
<b>Performance</b>	V/F Control	<p>Speed regulation: 1% of the rated speed (with sleep compensation)</p> <p>Speed variation range: 1:20</p>
	Vector control (VVV)	<p>Speed regulation: 1% of the rated speed</p> <p>Speed variation range: 1:30</p>
<b>Inputs<sup>1)</sup></b>	Analog	<p>1 isolated input: 0 to 10 V or 0 to 20 mA or 4 to 20 mA</p> <p>Linearity error <math>\leq 0.25\%</math></p> <p>Impedance: 100 k<math>\Omega</math> for voltage input, 500 <math>\Omega</math> for current input</p> <p>Programmable functions</p> <p>Voltage on the inputs: 30 V dc</p>
	Digital	<p>4 isolated inputs.</p> <p>Programmable functions:</p> <ul style="list-style-type: none"> <li>- Active high (PNP): maximum low level of 10 V dc minimum high level 20 V dc</li> <li>- Active low (NPN): maximum low level of 5 V dc minimum high level of 10 V dc</li> </ul> <p>Maximum input voltage of 30 V dc</p> <p>Input current: 11 mA</p> <p>Max input current: 20 mA</p>
<b>Outputs<sup>1)</sup></b>	Relay	<p>1 relays with NO/NC contact</p> <p>Maximum voltage: 250 V ac</p> <p>Maximum current: 0.5 A</p> <p>Programmable functions</p>
	Power supply	10 V dc power supply maximum capacity: 50 mA
<b>Safety</b>	Protection	<p>Overcurrent/phase-phase short circuit in the output</p> <p>Under/overtoltage at the power supply</p> <p>Motor overload</p> <p>Overtemperature in the power module (IGBTs)</p> <p>External fault/alarm</p> <p>Programming error</p>
<b>Human machine interface (HMI)</b>	Built-in	<p>4 keys: run/stop, increment, decrement and setting LCD display</p> <p>Indication accuracy:</p> <ul style="list-style-type: none"> <li>- Current: 10% of the rated current</li> <li>- Speed resolution: 0.1 Hz</li> </ul>
<b>Communication</b>	Communication networks or accessibility	Modbus-TCP, RS485, RS232, CANopen, DeviceNet, Ethernet, Profibus-DP or USB Port, Bluetooth® (with plug-in modules)
<b>Protection rating</b>	IP20	Frames A, B and C

Note: 1) Available in the standard version.

## Block Diagram

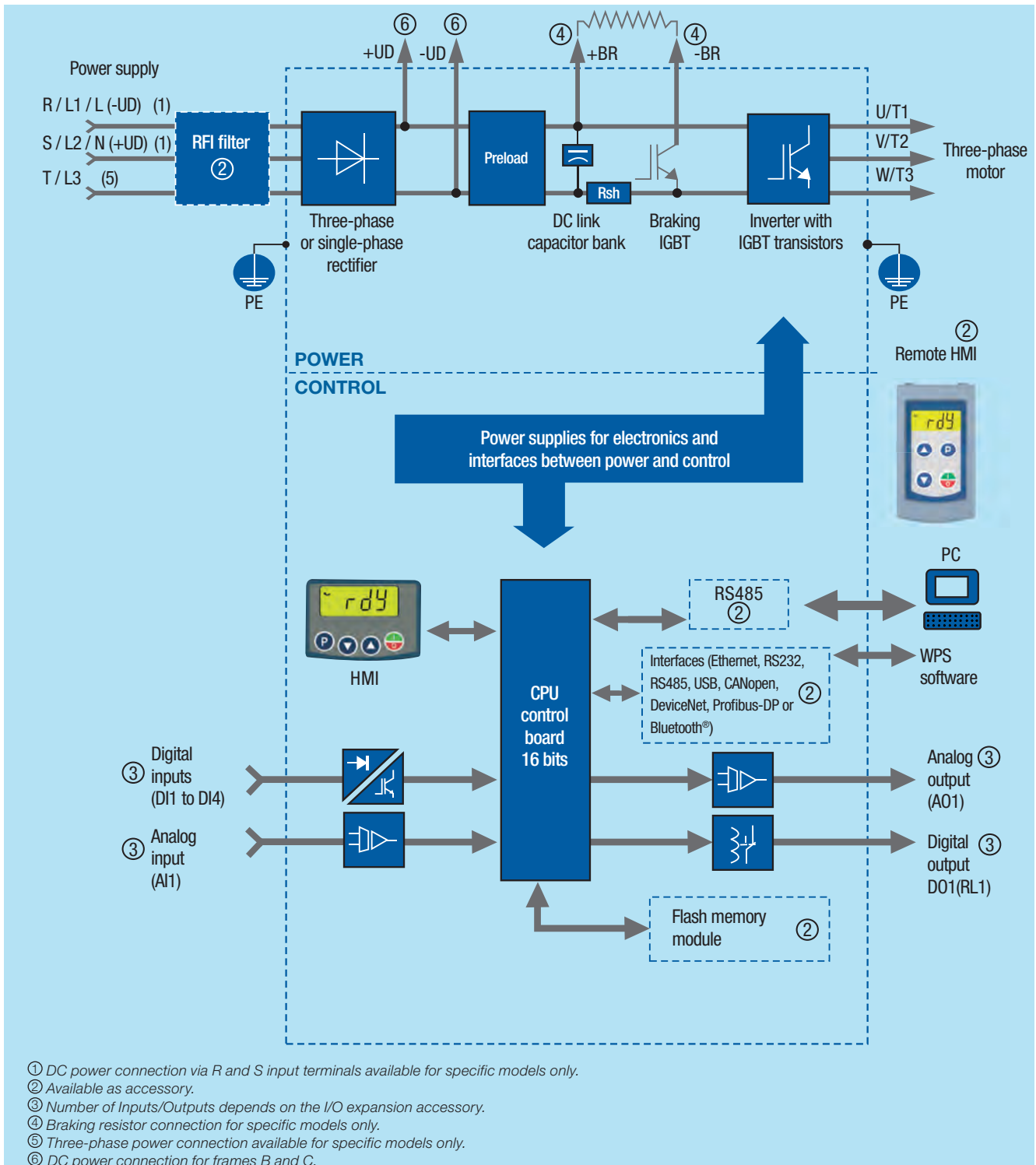





# Global presence is essential. As much as understanding what you need.

## Global Presence

With more than 30,000 employees worldwide, WEG is one of the largest electric motors, electronic equipments and systems manufacturers. We are constantly expanding our portfolio of products and services with expertise and market knowledge. We create integrated and customized solutions ranging from innovative products to complete after-sales service.

WEG's know-how guarantees our **CFW320 – Variable Speed Drive** is the right choice for your application and business, assuring safety, efficiency and reliability.



**Availability** is to have a global service network



**Partnership** is to create solutions that suit your needs



**Competitive edge** is to unite technology and innovation

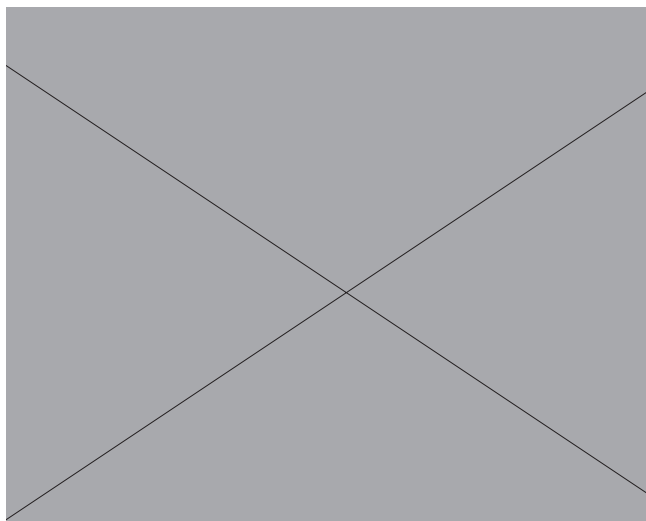

# Know More



High-performance and reliable products to improve your production process.



Excellence is to provide a whole solution that improves our customers' productivity.

Visit: [www.weg.net](http://www.weg.net)

 [youtube.com/wegvideos](https://youtube.com/wegvideos)

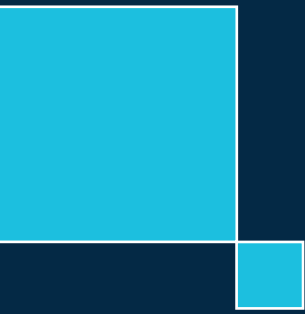

WEG's scope of solutions is not limited to the products and solutions presented in this brochure.

**Contact WEG for information on additional products and solutions.**

**For WEG's worldwide operations visit our website**



**[www.weg.net](http://www.weg.net)**



 1-800-ASK-4WEG

 [info-us@weg.net](mailto:info-us@weg.net)

 Duluth, GA