

Distributed by Gross Automation.
Please call +1 (262) 252-1600 or email sales@grossautomation.com

CPTW - INDUSTRIAL CONTROL POWER TRANSFORMERS

Utilizing superior insulation and construction for
optimized performance.

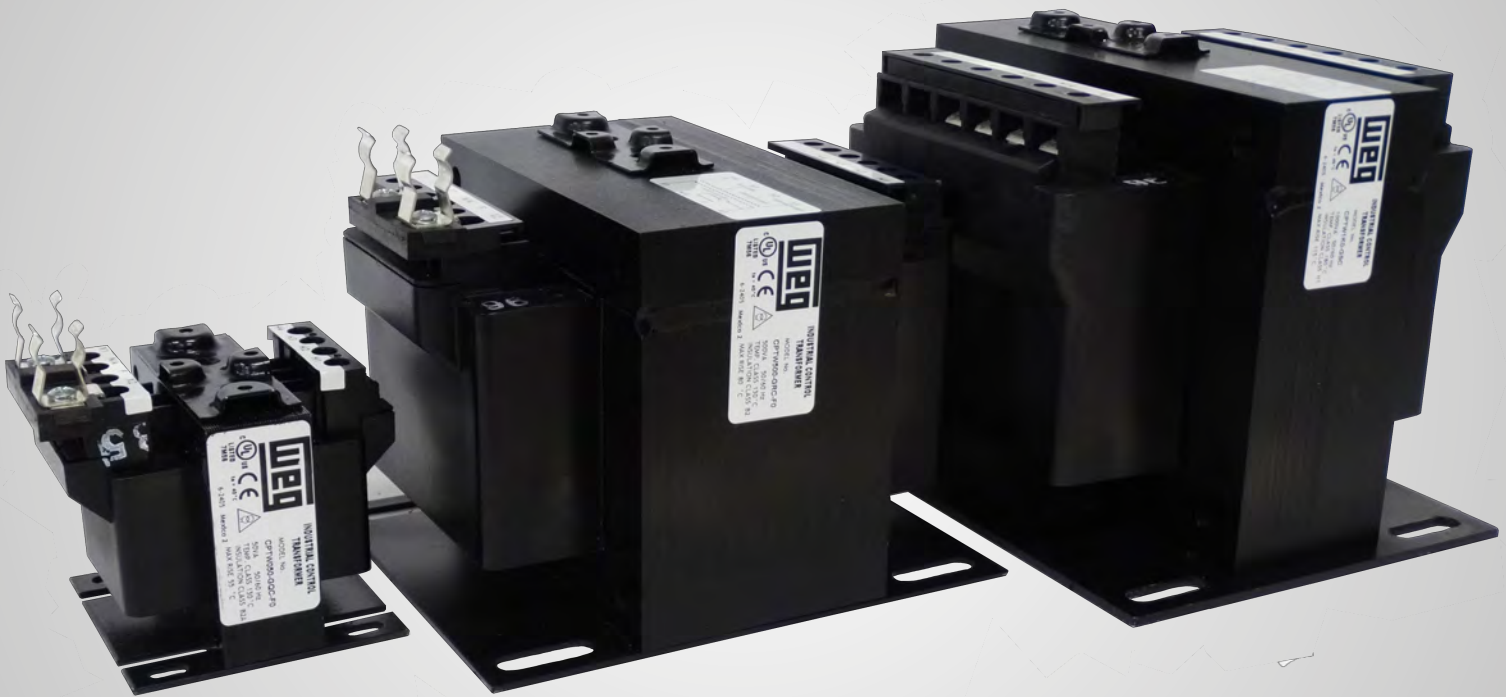

Motors | Automation | Energy | Transmission & Distribution | Coatings

Distributed by Gross Automation.
Please call +1 (262) 252-1600 or email sales@grossautomation.com

UL LISTED TMSB

UL US C E

6-2A05



Mexico 2

TRANSFORMER
MODEL NO.
CPTM500-01
500VA 501E
TEMP. CLASS
INSULATION
MAX RISE B

CPTW - Industrial Control Power Transformers

Summary

Introduction	04
Product Features	05
How to Select the Proper Transformer	06
Selection Table	07
Accessories	11
Technical Data	13
Wiring Diagrams	14
Dimensions	15

The best solution for accommodating the momentary current inrush caused when electromagnetic components are energized.

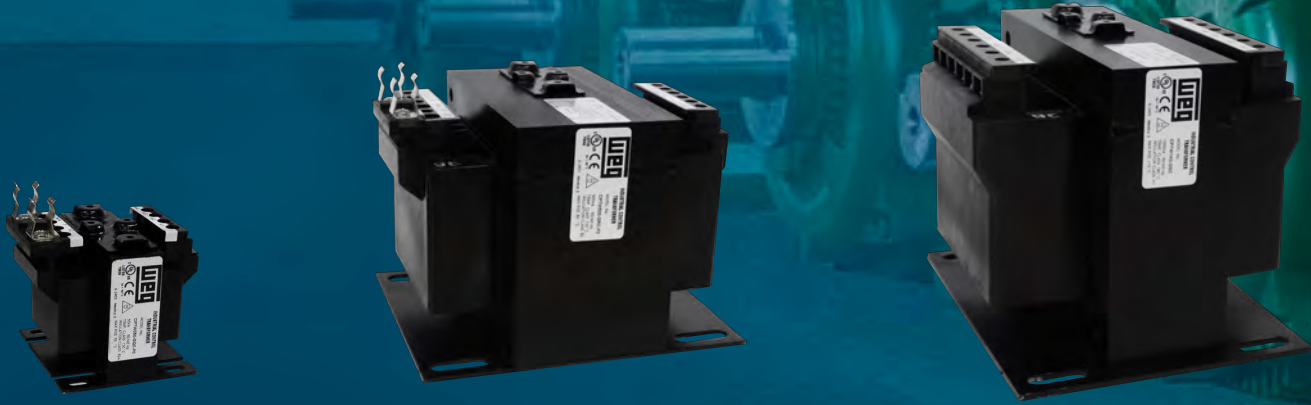

SECONDARY FUSE CLIPS INCLUDED

CPTWs up to 750VA come with pre-installed secondary fuse kits, ready to accept 13/32" x 1 1/2" midget / Class CC fuses.

ADD FUSE BLOCKS EASILY

Standard built-in mounting plate for easy installation of ALL optional fuse blocks up to 3KVA.

INCREASED SAFETY

Built-in, finger-safe terminals provide up to 30% greater terminal contact area. The extra deep barriers reduce the chance of shorts from frayed leads or careless wiring.

HIGH EFFICIENCY

Core losses are decreased due to use of high-grade silicon steel laminations and fine quality copper magnet wire.

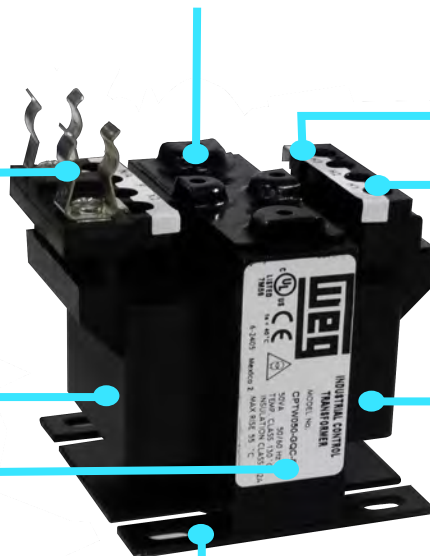

SECURE WIRING

Pressure plate terminals have a full quarter inch of thread on a 8-32 terminal screw. The terminals accept bare wire, ferrules, spades or ring lugs, while preventing stripping and pullout.

EASY TO LOCATE INFORMATION

All WEG control power transformers come labeled with power specifications, agency listings and part number. Additionally, a wiring diagram label for both Primary and Secondary wiring is included.

FLEXIBLE MOUNTING

Mounting plate is made of heavy gauge steel to add strength and provide stability. Slotted mounting feet permit easy and flexible installation.

DIRTY ENVIRONMENTS, NO PROBLEM

CPTWs are constructed with completely encapsulated coils to protect against moisture, dirt, dust and industrial contaminants for maximum protection in industrial environments.

Product Features

❖ **Completely Encapsulated Coils**

- The transformer coils are completely encapsulated for maximum protection in industrial environments.
- Protects against moisture, dirt, dust, and industrial contaminants.

❖ **Integrated Finger-Safe Terminals**

- Built-in, finger-safe terminals provide up to 30% greater terminal contact area which permits low-loss connections.
- Extra deep barriers reduce the chance of short circuits from frayed leads or careless wiring.

❖ **Terminals are Molded into the Transformer**

- Molded terminals result in a more robust and compact design.
- Fully threaded quarter-inch long terminal screws prevent stripping and pullouts.
- Terminals are designed to accept bare wire, ferrules, spade, or ring lugs.

❖ **Quality Materials**

- All CPTW Control Power Transformers are constructed with high-grade silicon steel laminations.
- The high-grade silicon steel cores are machine wound with high quality copper magnet wire for increased electrical resistivity and durability.

❖ **Insulation System and Temperature Rise**

- Class 130°C (266°F) insulation system with 55°C (131°F) temperature rise on 50 - 100VA.
- Class 130°C (266°F) insulation system with 80°C (176°F) temperature rise on 150 - 750VA
- Class 180°C (356°F) insulation system with 115°C (239°F) temperature rise on 1000 - 5000VA

❖ **Certifications**

- All the CPTW Control Power Transformers come UL, cUL, CSA, and CE certified.

❖ **Standard Accessories**

- All transformers up to 750VA come standard with secondary fuse clips.
- Two parallel jumper links come standard with transformers with dual primary voltages.

❖ **Interchangeable Accessories**

- All CPTW up to 3kVA include a mounting adapter for fuse blocks allowing greater flexibility and panel space optimization.
- Fuse and terminal covers provide protection from accidental electrical contact.

How to Select the Proper CPTW Control Power Transformer.

Transformer selection requires the following information.

- **Inrush VA** is the product of Load Voltage (V) multiplied by the current (A) that is required during circuit start-up. It is calculated by adding the Inrush VA requirements of all devices (contactors, timers, relays, pilot lights, solenoids, etc.), which will be energized together. Inrush VA requirements are best obtained from the component manufacturer.
- **Sealed VA** is also called Steady State VA and is the product of Load Voltage (V) multiplied by the current (A) after initial start-up or under normal operating conditions. It is calculated by adding the Sealed VA requirements of all electrical components that will be energized at any given time. Sealed VA requirements are best obtained from the component manufacturer.
- **Primary voltage** is the voltage available from the electrical distribution system and its operational frequency. This is the power which is connected to the transformer supply voltage terminals.
- **Secondary voltage** is the voltage required for load operation. This is the power which is available from the transformer load voltage terminals.

Once that information is known, the steps are as follows:

1. Calculate the Application Inrush VA by using the following formula:

$$\text{Application Inrush VA} = \sqrt{(\text{Inrush VA})^2 + (\text{Sealed VA})^2}$$

2. Refer to the Inrush Regulation Data Chart below. If the primary voltage is stable and does not vary by more than 5% from nominal, the 90% secondary voltage column should be used. If the primary voltage varies between 5% and 10% of the nominal voltage, the 95% secondary voltage column should be used.
3. After determining the proper secondary voltage column, read down until a value equal to or greater than the application inrush VA is found. In no case should a figure less than the application inrush VA be used.
4. Read left to the Transformer VA Rating column to determine the proper transformer rating for this application. As a final check, make sure that the Transformer VA Rating is equal to or greater than the total sealed requirements. If not, select a transformer with a VA rating equal to or greater than the total sealed VA.

Inrush Regulation Data Chart

Continuous VA Transformer Rating	Secondary Voltage		
	85%	90%	95%
50	200	167	131
75	311	257	200
100	471	377	276
150	923	716	491
200	1125	883	622
250	1944	1476	970
300	2040	1547	1020
350	3300	2400	1400
500	3191	2500	1745
750	6025	4520	2915
1000	8100	5600	3000
1500	16000	12000	6600
2000	19500	13500	7300
3000	25500	18250	10500
5000	75000	56000	33000

Note:

To comply with NEMA standards, which require all magnetic devices to operate successfully at 85% of rated voltage, the 90% secondary voltage column is most often used in selecting a transformer.

Selection Table

CPTW Transformer Catalog Number Sequence

CPTW 150 -A Q C -F0

**CPTW :
Controls Power
Transformer**

**Certification
C : CE and cULus**

VA Rating

050 : 50 VA	500 : 500 VA
075 : 75 VA	750 : 750 VA
100 : 100 VA	1000 : 1K0 VA
150 : 150 VA	1500 : 1K5 VA
200 : 200 VA	2000 : 2K0 VA
250 : 250 VA	3000 : 3K0 VA
350 : 350 VA	5000 : 5K0 VA

Voltage

	Primary	Secondary
A	220/440, 230/460, 240/480	110/115/120
E	550/575/600	110/115/120
G	200/220/440, 208/230/460, 240/480	110/115/120

Insulation / Temperature Rise

Q : Class 130°C (266°F) Insulation / 55°C (131°F) Temperature Rise
R : Class 130°C (266°F) Insulation / 80°C (176°F) Temperature Rise
S : Class 180°C (356°F) Insulation / 115°C (239°F) Temperature Rise

Factory Installed Accessory

F0 : Secondary Fuse Clip (13/32 x 1 1/2" midget / Class CC fuse)

Table intended as reference only and not to create part numbers.

Selection Table



UL File No.
E535994

Group A

Primary Voltage - 220/440, 230/460, 240/480

Secondary Voltage - 110/115/120

Group	Primary Voltage (VAC)	Secondary Voltage (VAC)	VA	Secondary Fuse Clips Included	Catalog Number	Material Number
A	220/440, 230/460, 240/480	110/115/120	50	Yes	CPTW050-AQC-F0	17414167
			75	Yes	CPTW075-AQC-F0	17414440
			100	Yes	CPTW100-AQC-F0	17414441
			150	Yes	CPTW150-ARC-F0	17414447
			250	Yes	CPTW250-ARC-F0	17414900
			350	Yes	CPTW350-ARC-F0	17414901
			500	Yes	CPTW500-ARC-F0	17414902
			750	Yes	CPTW750-ARC-F0	17414904
			1000	No	CPTW1K0-ASC	17414905
			1500	No	CPTW1K5-ASC	17414907
			2000	No	CPTW2K0-ASC	17415089
			3000	No	CPTW3K0-ASC	1741590
			5000	No	CPTW5K0-ASC	17415092

With Fuse Clip - F0

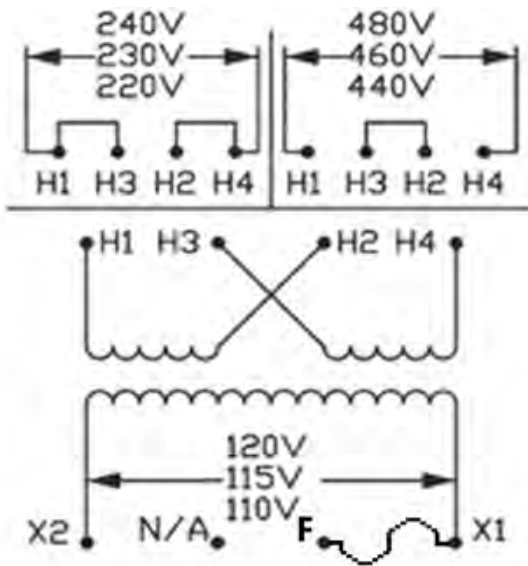

Without Fuse Clip

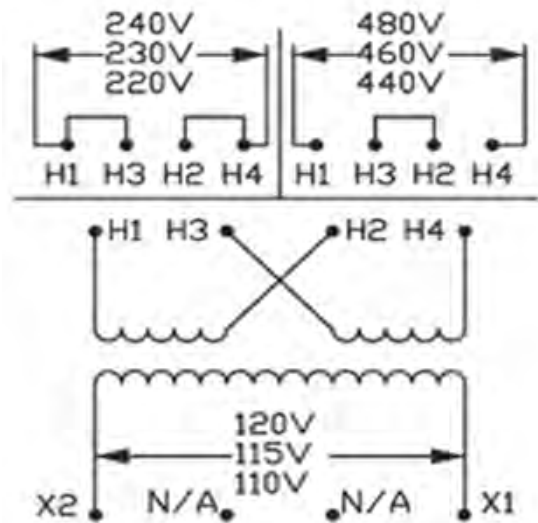



Selection Table



UL File No.
E535994

Group E

Primary Voltage - 550/575/600

Secondary Voltage - 110/115/120

Group	Primary Voltage (VAC)	Secondary Voltage (VAC)	VA	Secondary Fuse Clips Included	Catalog Number	Material Number
E	550/575/600	110/115/120	50	Yes	CPTW050-EQC-F0	17415097
			75	Yes	CPTW075-EQC-F0	17415258
			100	Yes	CPTW100-EQC-F0	17415261
			150	Yes	CPTW150-ERC-F0	17415262
			250	Yes	CPTW250-ERC-F0	17415264
			350	Yes	CPTW350-ERC-F0	17415265
			500	Yes	CPTW500-ERC-F0	17415266
			750	Yes	CPTW750-ERC-F0	17415267
			1000	No	CPTW1K0-ESC	17415459
			3000	No	CPTW3K0-ESC	17415461
			5000	No	CPTW5K0-ESC	17415463

With Fuse Clip - F0

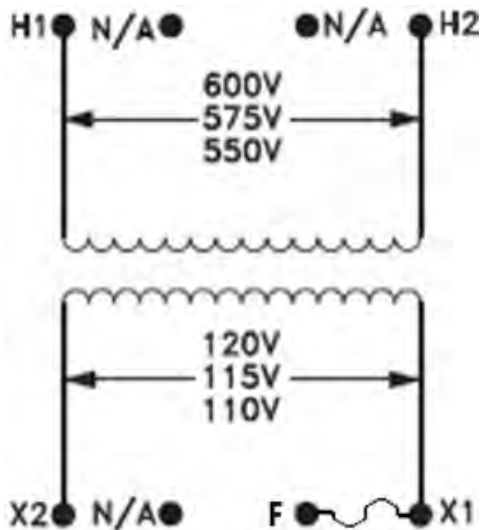

Without Fuse Clip

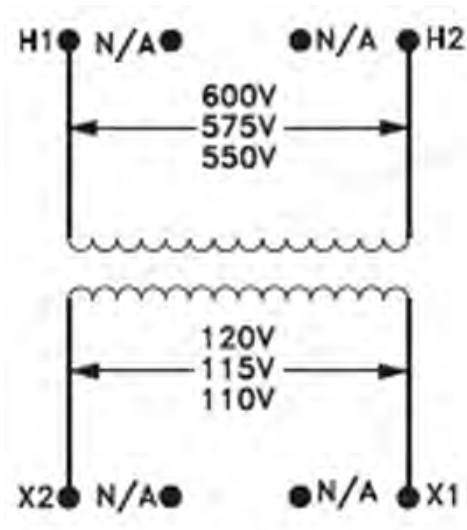

Selection Table



UL File No.
E535994

Group G

Primary Voltage - 200/220/440, 208/230/460, 240/480

Secondary Voltage - 110/115/120

Group	Primary Voltage (VAC)	Secondary Voltage (VAC)	VA	Secondary Fuse Clips Included	Catalog Number	Material Number
G	200/220/440, 208/230/460, 240/480	110/115/120	50	Yes	CPTW050-GQC-F0	17415464
			75	Yes	CPTW075-GQC-F0	17415466
			100	Yes	CPTW100-GQC-F0	17415579
			150	Yes	CPTW150-GRC-F0	17416639
			200	Yes	CPTW200-GRC-F0	17673515
			250	Yes	CPTW250-GRC-F0	17416640
			350	Yes	CPTW350-GRC-F0	17416643
			500	Yes	CPTW500-GRC-F0	17416645
			750	Yes	CPTW750-GRC-F0	17416647
			1000	No	CPTW1K0-GSC	17416741
			1500	No	CPTW1K5-GSC	17416742
			2000	No	CPTW2K0-GSC	17416744
			3000	No	CPTW3K0-GSC	17416745
			5000	No	CPTW5K0-GSC	17416746

With Fuse Clip - F0

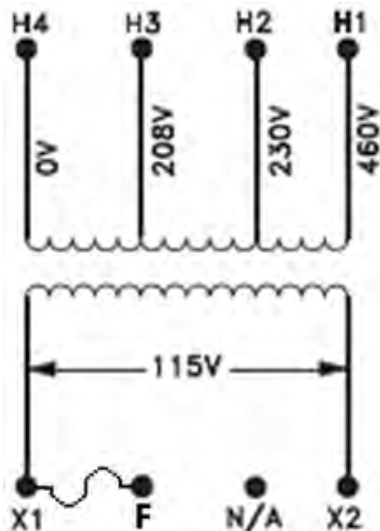

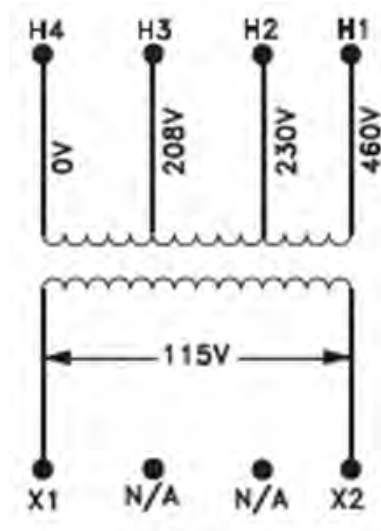

Without Fuse Clip



Accessories

Fuse Covers

For Use With	Illustrative Picture	Description	Catalog Number	Material Number
Fits any fuse block		Fuse block cover with puller	CPTW-ACC-1401	17420105
Fits any fuse clip		Fuse clip cover	CPTW-ACC-2401	17420107

Secondary Fuse Clips

For Use With	Illustrative Picture	Description	Catalog Number	Material Number
CPTW050...750		Secondary fuse clip (13/32" x 1 1/2" midget / Class CC fuse)	CPTW-ACC-2111	17420200
CPTW1K0 - 5K0		Secondary fuse clip (13/32" x 1 1/2" midget / Class CC fuse)	CPTW-ACC-2121	17420203

Secondary Fuse Block

For Use With	Illustrative Picture	Description	Catalog Number	Material Number
Fits all models		Single pole Secondary fuse block (Class CC)	CPTW-ACC-2201	17420205

Primary Fuse Block

For Use With	Illustrative Picture	Description	Catalog Number	Material Number
Fits all models		Dual pole Primary fuse block (Class CC)	CPTW-ACC-1201	17420207

Accessories





Primary Fuse Block and Secondary Fuse Clip

For Use With	Illustrative Picture	Description	Catalog Number	Material Number
Fits all models		Dual pole Primary fuse block (Class CC) and Secondary fuse clip (13/32"x 1 1/2" midget / Class CC fuse)	CPTW-ACC-3201	17420279

Primary Fuse Block and Secondary Fuse Block

For Use With	Illustrative Picture	Description	Catalog Number	Material Number
CPTW150...5K0		Dual pole Primary fuse block (Class CC) and Single pole Secondary fuse block (Class CC)	CPTW-ACC-3231	17420278

Terminal Covers

For Use With	Illustrative Picture	Description	Catalog Number	Material Number
CPTW050...350		4 Position Terminal Covers (25 Pack)	CPTW-ACC-4312	17420281
CPTW050...350		4 Position Terminal Covers for Secondary Fuse Clip (25 Pack)	CPTW-ACC-4412	17420282
CPTW500...750		6 Position Terminal Covers (25 Pack)	CPTW-ACC-6342	17420284
CPTW500...750		6 Position Terminal Covers for Secondary Fuse Clip (25 Pack)	CPTW-ACC-6442	17420285
CPTW1K0...5K0		6 Position Terminal Covers (25 Pack)	CPTW-ACC-6452	17420286



Technical Data

PRIMARY STANDARD FUSE AMPERAGE RATING

VA Rating	Voltage AC 50/60 Hz																
	115	120	200	208	220	230	240	277	380	400	415	440	460	480	550	575	600
50	1.00	1.00	0.60	0.60	0.50	0.50	0.50	0.40	0.30	0.30	0.30	0.25	0.25	0.25	0.25	0.25	0.25
75	1.60	1.50	0.80	0.80	0.80	0.80	0.75	0.60	0.50	0.40	0.40	0.40	0.40	0.40	0.30	0.30	0.30
100	2.00	2.00	1.25	1.13	1.00	1.00	1.00	0.80	0.60	0.60	0.60	0.50	0.50	0.50	0.40	0.40	0.40
150	3.20	3.00	1.80	1.80	1.60	1.60	1.50	1.30	0.80	0.80	0.80	0.80	0.80	0.75	0.60	0.60	0.60
250	5.00	5.00	3.00	3.00	2.80	2.50	2.50	2.00	1.60	1.50	1.50	1.40	1.30	1.30	1.00	1.00	1.00
350	7.50	7.00	4.00	4.00	3.50	3.50	3.50	3.00	2.25	2.00	2.00	1.80	1.80	1.80	1.60	1.50	1.40
500	10.0	10.0	6.25	6.00	5.60	5.00	5.00	4.50	3.20	3.00	3.00	2.80	2.50	2.50	2.00	2.00	2.00
750	15.0	15.0	9.00	9.00	8.00	8.00	7.50	6.25	4.50	4.50	4.50	4.00	4.00	3.50	3.20	3.20	3.00
1000	20.0	20.0	12.0	12.0	10.0	10.0	10.0	9.00	6.25	6.25	6.00	5.60	5.00	5.00	4.50	4.00	4.00
1500	30.0	30.0	17.5	17.5	15.0	15.0	15.0	12.0	9.00	9.00	9.00	8.00	8.00	7.50	6.25	6.25	6.25
2000	-	-	25.0	20.0	20.0	20.0	20.0	17.5	12.0	12.0	12.0	10.0	10.0	10.0	9.00	8.00	8.00
3000	-	-	-	-	30.0	30.0	30.0	25.0	17.5	17.5	17.5	15.0	15.0	15.0	12.0	12.0	12.0
5000	-	-	-	-	-	-	-	-	30.0	30.0	30.0	25.0	25.0	25.0	20.0	20.0	20.0

SECONDARY STANDARD FUSE AMPERAGE RATING

VA Rating	Voltage AC 50/60 Hz												
	12	23	24	25	90	95	100	110	115	120	220	230	240
50	6.25	3.50	3.20	3.20	0.80	0.80	0.80	0.75	0.70	0.60	0.30	0.30	0.30
75	10.0	5.00	5.00	5.00	1.30	1.30	1.25	1.00	1.00	1.00	0.50	0.50	0.50
100	12.0	7.00	6.25	6.25	1.80	1.60	1.60	1.50	1.40	1.30	0.75	0.70	0.60
150	15.0	10.0	10.0	10.0	2.50	2.50	2.50	2.00	2.00	2.00	1.00	1.00	1.00
250	25.0	15.0	15.0	15.0	4.50	4.00	4.00	3.50	3.50	3.20	1.80	1.80	1.60
350	-	20.0	20.0	15.0	6.25	6.00	5.60	5.00	5.00	4.50	2.50	2.50	2.25
500	-	30.0	30.0	25.0	9.00	8.00	8.00	7.50	7.00	6.25	3.50	3.50	3.20
750	-	-	-	-	12.0	12.0	12.0	10.0	10.0	10.0	5.60	5.00	5.00
1000	-	-	-	-	15.0	15.0	15.0	12.0	12.0	12.0	7.50	7.00	6.25
1500	-	-	-	-	25.0	20.0	20.0	15.0	15.0	15.0	10.0	10.0	10.0
2000	-	-	-	-	30.0	30.0	25.0	25.0	25.0	25.0	12.0	12.0	12.0
3000	-	-	-	-	-	-	-	-	-	-	15.0	15.0	15.0
5000	-	-	-	-	-	-	-	-	-	-	30.0	30.0	30.0

PRIMARY AND SECONDARY PROTECTION

Fuse sizing is based on NEC 4503		
Rated Secondary Current in Amps	Maximum Priary Fuse Size	Maximum Secondary Fuse
Less than 9 amps	250% or next size smaller	167% or next size smaller
Greater than or equal to 9 amps	250% or next size smaller	125% or next size smaller

Wiring Diagrams

Group A

PRIMARY VOLTAGE VAC 50/60 Hz	SECONDARY VOLTAGE VAC 50/60 Hz
220/440, 230/460, 240/480	110/115/120

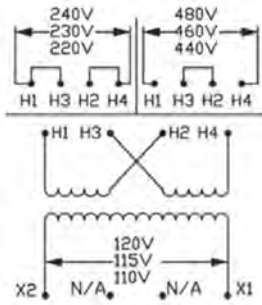

PRIMARY VOLTS	JUMPERS	PRIMARY LINE LEADS
220/230/240	H1-H3, H2-H4	H1, H4
440/460/480	H2-H3	H1, H4

SECONDARY VOLTS	CONNECTIONS	SECONDARY LINE LEADS
110/115/120	N/A	X1, X2

Group E

PRIMARY VOLTAGE VAC 50/60 Hz	SECONDARY VOLTAGE VAC 50/60 Hz
550/575/600	110/115/120

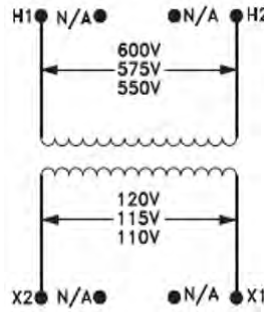

PRIMARY VOLTS	JUMPERS	PRIMARY LINE LEADS
550/575/600	N/A	H1, H2

SECONDARY VOLTS	CONNECTIONS	SECONDARY LINE LEADS
110/115/120	N/A	X1, X2

Group G

PRIMARY VOLTAGE VAC 50/60 Hz	SECONDARY VOLTAGE VAC 50/60 Hz
200/220/440, 208/230/460, 240/480	110/115/120

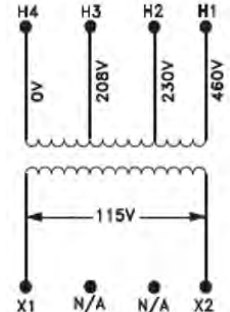

PRIMARY VOLTS	JUMPERS	PRIMARY LINE LEADS
200/208	N/A	H3, H4
220/230/240	N/A	H2, H4
440/460/480	N/A	H1, H4

SECONDARY VOLTS	CONNECTIONS	SECONDARY LINE LEADS
110/115/120	N/A	X1, X2

Group A with secondary fusing

PRIMARY VOLTAGE VAC 50/60 Hz	SECONDARY VOLTAGE VAC 50/60 Hz
220/440, 230/460, 240/480	110/115/120

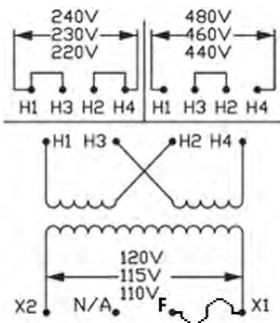

PRIMARY VOLTS	JUMPERS	PRIMARY LINE LEADS
220/230/240	H1-H3, H2-H4	H1, H4
440/460/480	H2-H3	H1, H4

SECONDARY VOLTS	CONNECTIONS	SECONDARY LINE LEADS
110/115/120	N/A	F, X2

Group E with secondary fusing

PRIMARY VOLTAGE VAC 50/60 Hz	SECONDARY VOLTAGE VAC 50/60 Hz
550/575/600	110/115/120

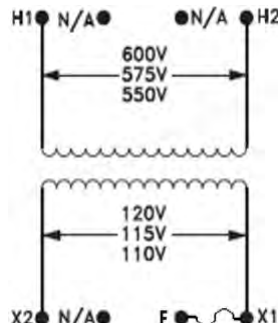

PRIMARY VOLTS	JUMPERS	PRIMARY LINE LEADS
550/575/600	N/A	H1, H2

SECONDARY VOLTS	CONNECTIONS	SECONDARY LINE LEADS
110/115/120	N/A	F, X2

Group G with secondary fusing

PRIMARY VOLTAGE VAC 50/60 Hz	SECONDARY VOLTAGE VAC 50/60 Hz
200/220/440, 208/230/460, 240/480	110/115/120

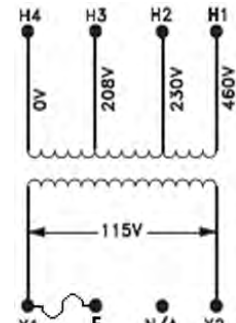

PRIMARY VOLTS	JUMPERS	PRIMARY LINE LEADS
200/208	N/A	H3, H4
220/230/240	N/A	H2, H4
440/460/480	N/A	H1, H4

SECONDARY VOLTS	CONNECTIONS	SECONDARY LINE LEADS
110/115/120	N/A	F, X2

Dimensions - Inch

Group A Frame Sizes

Primary Voltage - 220/440, 230/460, 240/480

Secondary Voltage - 110/115/120

50VA - 350VA

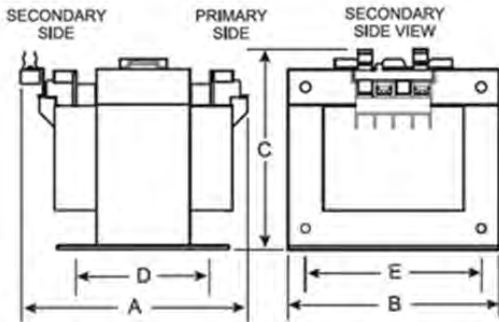

500VA - 5000VA

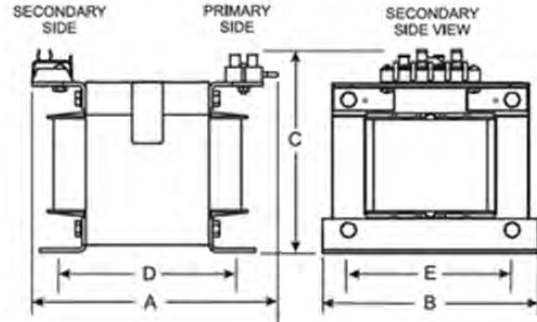

Transformers 50VA - 350VA have 4 terminals per side.

Transformers 500VA - 5000VA have 6 terminals per side.

* Images are a general representation of a CPTW Control Transformer without fusing accessories or jumper links.

GROUP A												
Primary		220/440, 230/460, 240/480										
Secondary		110/115/120										
Approximate Dimensions (In.) and Weight (lbs.)												
VA Rating	Part #	Max. Depth (A)	Max. Width (B)	Max. Height (C)	Mounting Depth (D)	Mounting Width (E)	Mounting Hole Depth	Mounting Hole Width	Temp Rise	Insulation	Est. Shipping Weight	
50	CPTW050-AQC-F0	3.32	3.00	2.79	2.00	2.50	0.20	0.41	55°C (131°F)	130°C (266°F)	2.60	
75	CPTW075-AQC-F0	3.82	3.00	2.79	2.50	2.50	0.20	0.41	55°C (131°F)	130°C (266°F)	3.50	
100	CPTW100-AQC-F0	3.78	3.38	3.10	2.38	2.81	0.20	0.41	55°C (131°F)	130°C (266°F)	4.20	
150	CPTW150-ARC-F0	4.27	3.75	3.41	2.88	3.13	0.20	0.41	80°C (176°F)	130°C (266°F)	6.70	
250	CPTW250-ARC-F0	4.55	4.50	4.04	2.88	3.75	0.20	0.41	80°C (176°F)	130°C (266°F)	10.0	
350	CPTW350-ARC-F0	5.28	4.50	4.04	3.75	3.75	0.20	0.41	80°C (176°F)	130°C (266°F)	13.6	
500	CPTW500-ARC-F0	5.75	5.25	4.66	4.25	4.38	0.31	1.06	80°C (176°F)	130°C (266°F)	15.8	
750	CPTW750-ARC-F0	7.00	5.25	4.66	5.38	4.38	0.31	1.06	80°C (176°F)	130°C (266°F)	28.1	
1000	CPTW1K0-ASC	6.61	7.00	5.65	4.00	6.13	0.31	1.06	115°C (239°F)	180°C (356°F)	29.8	
1500	CPTW1K5-ASC	7.62	7.00	5.65	4.50	6.13	0.31	1.06	115°C (239°F)	180°C (356°F)	30.0	
2000	CPTW2K0-ASC	8.37	7.00	5.65	5.13	6.13	0.31	1.06	115°C (239°F)	180°C (356°F)	38.0	
3000	CPTW3K0-ASC	7.82	9.00	7.62	4.25	6.50	0.44	1.00	115°C (239°F)	180°C (356°F)	53.0	
5000	CPTW5K0-ASC	9.06	9.00	7.62	7.25	7.50	0.44	1.00	115°C (239°F)	180°C (356°F)	89.0	

Notes:

* Jumper Link and Fuse Clip height not included

** Add 5/16" to the Depth (A) when fuse clips are included (50 thru 350VA)

*** Add 1 3/8" to the Height (D) when fuse block is included (1, 2, and 3 poles) (50 thru 350VA)

**** Add 1/2" to the Height (D) when fuse block is included (1, 2, and 3 poles) (500 thru 5000VA)

Dimensions - Inch

Group E Frame Sizes

Primary Voltage - 550/575/600

Secondary Voltage - 110/115/120

50VA - 350VA

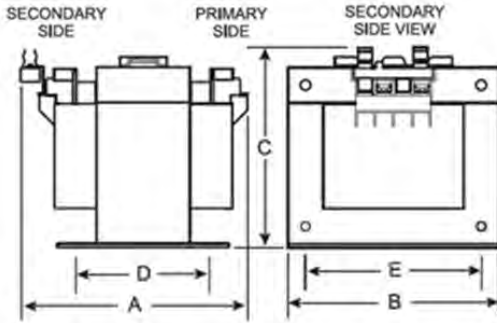

500VA - 5000VA

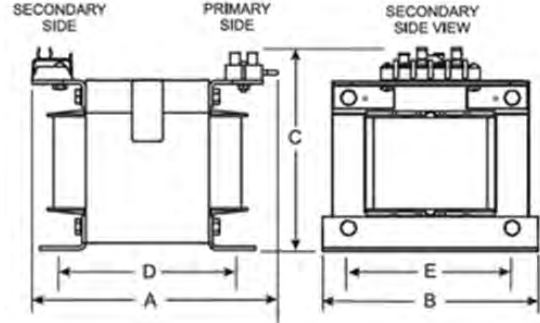

Transformers 50VA - 350VA have 4 terminals per side.

Transformers 500VA - 5000VA have 6 terminals per side.

* Images are a general representation of a CPTW Control Transformer without fusing accessories or jumper links.

GROUP E											
Primary		550/575/600									
Secondary		110/115/120									
Approximate Dimensions (In.) and Weight (lbs.)											
VA Rating	Part #	Max. Depth (A)	Max. Width (B)	Max. Height (C)	Mounting Depth (D)	Mounting Width (E)	Mounting Hole Depth	Mounting Hole Width	Temp Rise	Insulation	Est. Shipping Weight
50	CPTW050-EQC-F0	3.23	3.00	2.79	2.00	2.50	0.20	0.41	55°C (131°F)	130°C (266°F)	2.60
75	CPTW075-EQC-F0	3.73	3.00	2.79	2.50	2.50	0.20	0.41	55°C (131°F)	130°C (266°F)	3.50
100	CPTW100-EQC-F0	3.69	3.38	3.11	2.38	2.81	0.20	0.41	55°C (131°F)	130°C (266°F)	4.20
150	CPTW150-ERC-F0	4.17	3.75	3.42	2.88	3.13	0.20	0.41	80°C (176°F)	130°C (266°F)	6.70
250	CPTW250-ERC-F0	4.47	4.50	4.04	2.88	3.75	0.20	0.41	80°C (176°F)	130°C (266°F)	10.0
350	CPTW350-ERC-F0	5.19	4.50	4.04	3.75	3.75	0.20	0.41	80°C (176°F)	130°C (266°F)	13.6
500	CPTW500-ERC-F0	5.17	5.25	4.66	4.25	4.38	0.31	1.06	80°C (176°F)	130°C (266°F)	15.9
750	CPTW750-ERC-F0	6.42	5.25	4.66	5.38	4.38	0.31	1.06	80°C (176°F)	130°C (266°F)	28.1
1000	CPTW1K0-ESC	6.21	7.00	5.65	4.00	6.13	0.31	1.06	115°C (239°F)	180°C (356°F)	29.8
3000	CPTW3K0-ESC	7.82	9.00	7.62	4.25	6.50	0.44	1.00	115°C (239°F)	180°C (356°F)	53.0
5000	CPTW5K0-ESC	9.06	9.00	7.62	7.25	7.50	0.44	1.00	115°C (239°F)	180°C (356°F)	89.0

Notes:

* Jumper Link and Fuse Clip height not included

** Add 5/16" to the Depth (A) when fuse clips are included (50 thru 350VA)

*** Add 1 3/8" to the Height (D) when fuse block is included (1, 2, and 3 poles) (50 thru 350VA)

**** Add 1/2" to the Height (D) when fuse block is included (1, 2, and 3 poles) (500 thru 5000VA)

Dimensions - Inch

Group G Frame Sizes

Primary Voltage - 200/220/240, 208/230/460, 240/480

Secondary Voltage - 110/115/120

50VA - 350VA

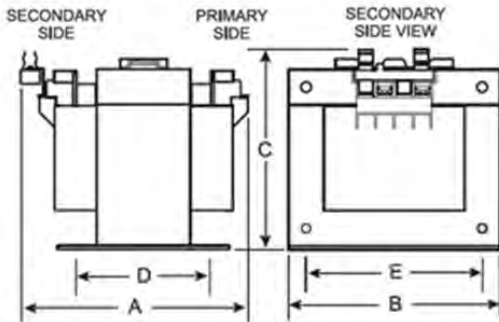

500VA - 5000VA

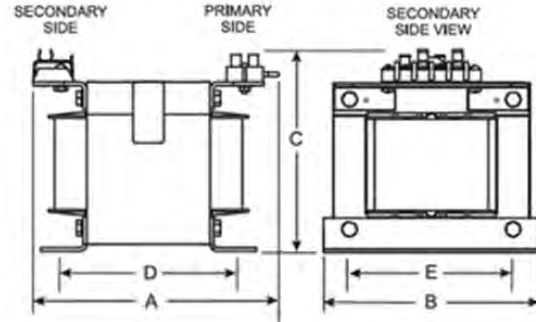

Transformers 50VA - 350VA have 4 terminals per side.

Transformers 500VA - 5000VA have 6 terminals per side

* Images are a general representation of a CPTW Control Transformer without fusing accessories or jumper links.

GROUP G											
Primary	200/220/440, 208/230/460, 240/480										
Secondary	110/115/120										
Approximate Dimensions (In.) and Weight (lbs.)											
VA Rating	Part #	Max. Depth (A)	Max. Width (B)	Max. Height (C)	Mounting Depth (D)	Mounting Width (E)	Mounting Hole Depth	Mounting Hole Width	Temp Rise	Insulation	Est. Shipping Weight
50	CPTW050-GQC-F0	3.23	3.00	2.79	2.00	2.50	0.20	0.41	55°C (131°F)	130°C (266°F)	2.60
75	CPTW075-GQC-F0	3.73	3.00	2.79	2.50	2.50	0.20	0.41	55°C (131°F)	130°C (266°F)	3.50
100	CPTW100-GQC-F0	3.69	3.38	3.11	2.38	2.81	0.20	0.41	55°C (131°F)	130°C (266°F)	4.20
150	CPTW150-GRC-F0	4.17	3.75	3.42	2.88	3.13	0.20	0.41	80°C (176°F)	130°C (266°F)	6.70
200	CPTW200-GRC-F0	3.96	4.50	4.04	2.88	3.75	0.20	0.41	80°C (176°F)	130°C (266°F)	8.50
250	CPTW250-GRC-F0	4.47	4.50	4.04	3.25	3.75	0.20	0.41	80°C (176°F)	130°C (266°F)	10.0
350	CPTW350-GRC-F0	5.19	4.50	4.04	3.75	3.75	0.20	0.41	80°C (176°F)	130°C (266°F)	13.6
500	CPTW500-GRC-F0	5.17	5.25	4.66	4.75	4.38	0.31	1.06	80°C (176°F)	130°C (266°F)	16.0
750	CPTW750-GRC-F0	6.42	5.25	4.66	5.38	4.38	0.31	1.06	80°C (176°F)	130°C (266°F)	28.1
1000	CPTW1K0-GSC	6.21	7.00	5.65	4.00	6.13	0.31	1.06	115°C (239°F)	180°C (356°F)	29.8
1500	CPTW1K5-GSC	7.23	7.00	5.65	4.50	6.13	0.31	1.06	115°C (239°F)	180°C (356°F)	30.0
2000	CPTW2K0-GSC	7.98	7.00	5.43	5.13	6.13	0.31	1.06	115°C (239°F)	180°C (356°F)	38.0
3000	CPTW3K0-GSC	7.50	9.00	7.62	4.25	6.50	0.44	1.00	115°C (239°F)	180°C (356°F)	53.0
5000	CPTW5K0-GSC	9.00	9.00	7.62	7.25	7.50	0.44	1.00	115°C (239°F)	180°C (356°F)	89.0

Notes:

* Jumper Link and Fuse Clip height not included

** Add 5/16" to the Depth (A) when fuse clips are included (50 thru 350VA)

*** Add 1 3/8" to the Height (D) when fuse block is included (1, 2, and 3 poles) (50 thru 350VA)

**** Add 1/2" to the Height (D) when fuse block is included (1, 2, and 3 poles) (500 thru 5000VA)

Global presence is essential, as much as understanding your needs.

Global Presence

With more than 30,000 employees worldwide, WEG is one of the largest electric motors, electronic equipments and systems manufacturers. We are constantly expanding our portfolio of products and services with expertise and market knowledge. We create integrated and customized solutions ranging from innovative products to complete after-sales service.

WEG's know-how guarantees our **CPTW industrial control power transformers** are the right choice for your application and business, assuring safety, efficiency and reliability.



Availability is to have a global support network



Partnership is to create solutions that suit your needs



Competitive edge is to unite technology and innovation



Know More



High performance and reliable products
to improve your production process.

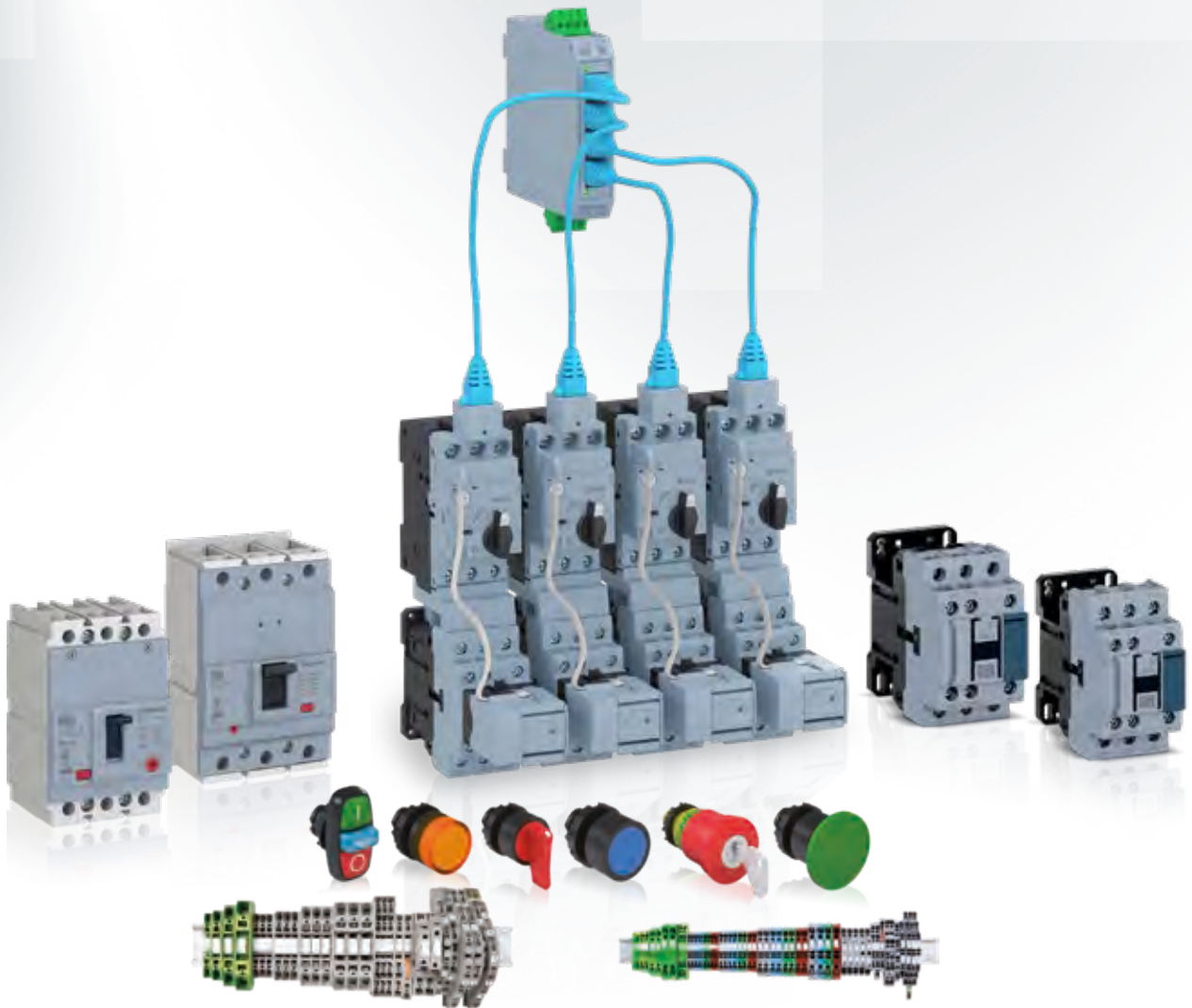

Excellence is to provide a whole solution in industrial automation that
improves our customers productivity.

Visit: www.weg.net

 youtube.com/wegvideos

**Distributed by Gross Automation.
Please call +1 (262) 252-1600
or email sales@grossautomation.com**

For WEG's
worldwide
operations visit our website



www.weg.net



 1-800-ASK-4WEG

 (275-4934) info-

 us@weg.net

Duluth, Georgia, USA