

CATALOG

Enclosed Softstarters

PSTX



Reliable motor operation is crucial to our modern way of life. ABB is powering progress — one motor at a time. The PSTX softstarter combines many years of research and product development with extensive knowledge of application-specific requirements and needs. It is our latest advancement in motor control and protection, adding new functionality and increased reliability.

Table of contents

004–005	Introduction
006–007	Common applications
008–009	Motor starting
010	Typical components
011	Certifications and approvals
012–014	Enclosed softstarters overview
015	Part numbering convention
016–018	Ordering details
019–020	Technical data
021–048	Dimensions
049–051	Representative circuit diagrams
052–053	Fieldbus communication
054–055	Marketing materials and tools

PSTX enclosed softstarters

An integrated solution

PSTX enclosed softstarters offer a comprehensive and easy-to-integrate solution for enclosed motor starting, ensuring reliable operation, efficient installation, and reduced total cost of ownership.



+



+



→



SOFTSTARTER BASE UNIT

- PSTX

MULTI-RATED ENCLOSURE

- UL Type 1 / 12 / 3R / 4

ELECTRICAL PROTECTION

- Fused disconnect
- Circuit breaker

ENCLOSED SOLUTION



SECURE MOTOR RELIABILITY

Our softstarters are designed to provide maximum motor protection against electrical stress, managing starting currents for your load, application and motor size. More than 10 built-in motor protection features safeguard your motor from various load and network irregularities.



IMPROVE INSTALLATION EFFICIENCY

With a compact design and numerous built-in features, our enclosed softstarters reduce installation time and panel size. The integrated bypass saves energy and space and reduces heat generation, providing a complete motor starting solution in one unit.



INCREASE APPLICATION PRODUCTIVITY

Our softstarters enable you to operate your process at its full potential by reducing mechanical stress on your motor application. Features like torque control, pump cleaning and motor brake allow for seamless integration into your production line or process, minimizing downtime and increasing system availability.

Case studies

Tasmanian salmon operation keeps its fish cool with ABB softstarters

Tassal upgrades the motor control center in Australia's biggest land-based salmon hatchery with ABB softstarters, ensuring the continuous operation of its water chillers.

For more information visit: [Link](#)

Reduced inrush current by 50%

Xylem - South Africa ABB softstarters providing efficiency to the mining industry

Xylem reduced the number of components by 80% and shortened installation time by 60%. Costs cut by half has helped Xylem sell twice as many panels with softstarters as before. For more information visit: [Link](#)

Total panel costs reduced by 50%

Indian tourist town is pumped up over ABB softstarters that help uninterrupted water supply

Shimla has cut pipeline damage by 50% using softstarters to help lift water thousands of feet from a dam to quench the thirst of millions. For more information visit: [Link](#)

Pipeline damage reduced by 50%



Common applications for softstarters

Pumps, fans, compressors and conveyors

A softstarter can do wonders for your operations. Packed with useful features, it reduces both mechanical and electrical stresses to your equipment, improves the reliability of your processes and increases overall productivity.



01 Softstarters
controlling pumps



02 Softstarters
controlling fans

Pump

Eliminating water hammering with torque control

Water hammering is a common problem with pumps and typically results in wear to pipes and valves when starting and stopping the pump. The torque control feature of ABB softstarters provides a soft pipe fill during start and eliminates water hammering during stop. The benefits are prolonged system life and increased uptime.

Keep pipes and pumps clean

Pumps are often prone to clogging over time, leading to reduced flow rates and increased risk of damage. However, with the reverse flow direction and kick-start features, ABB softstarters can effectively prevent and clear pump blockages, minimizing downtime and optimizing performance.

Avoid running dry with underload protection

Damage caused by running pumps dry can be prevented with ABB softstarters' built-in underload protection feature, also known as dry pump protection. This innovative technology stops the motor when it detects underload conditions, shielding the pump from excessive wear and tear and significantly extending its lifespan.

Fans

Soft starting adjusted to application

Fans normally have a high moment of inertia, which makes starting tough and current high. Using an ABB softstarter, the voltage is increased gradually during start, which reduces the current and removes the inrush peak. It is possible to adjust the settings to fit almost any starting condition, from unloaded to fully loaded.

Fast stops with motor braking

It can also take a long time to stop a fan. With the dynamic brake feature, also called flux braking, stopping time can be reduced. This improves process safety when the load has a high moment of inertia and makes fan operation easier for the operator.

Avoid unwanted movement with stand-still brake

An idle fan that is rotating backwards, due to wind or airflow from another fan, can be kept still using the stand-still brake. It prevents unwanted airflow and improves the control of the system without the need for an external mechanical brake.

01



02





03 Softstarters
controlling compressors



04 Softstarters
controlling
conveyor belts

Compressors

Full control of current with current limit

Many applications are sensitive to high or variable starting currents. The current limit feature makes it possible to start the motor securely even in a weak network, improving the availability of the equipment and system. Reducing the current means reducing the stress on cables, network, and motor.

Full voltage start for scroll compressors

For scroll compressors, it is often necessary to start the motor in a very short time while still maintaining a low starting current. Full voltage start is a start mode that gives you almost a direct start but without the current peak.

Phase reversal protection for problem-free commissioning

A motor rotating in the wrong direction, which may result from incorrect phase connection, can cause severe damage to a compressor. Using phase reversal protection, the motor won't start in the wrong direction, avoiding costly compressor downtime and repairs.

03



Conveyors

Avoid overheating with overload protection

Too much material on a conveyor belt may cause overload and overheating, reducing the reliability and longevity of the motor. ABB's overload protection feature shuts down the motor in case of overload, preventing damage and wear.

Increased flexibility with jog with slow speed

After stopping the belt, it may be necessary to run the motor at low speed to correctly position the belt before resuming operation. The jog with slow speed feature makes it possible to position the belt manually, in both forward and reverse direction, before restarting the belt. This improves process efficiency and eliminates the need for a variable speed drive, which is a considerably more expensive solution.

Continuous operation with limp mode

A thyristor short circuit is a possible problem for a softstarter, putting it out of operation until the component has been replaced. Using limp mode, the softstarter will continue to work with one thyristor shorted, making PSTX-based systems resilient to single faults, and avoiding costly unplanned stoppages.

04



Motor starting

Why motor starting and stopping matters

There are some common issues associated with starting and stopping electrical motors. Depending on requirement, different starting and stopping methods can be used.



Direct-on-line

Direct-on-line starting (DOL) is the easiest and most commonly used starting method. It is suitable for stable networks and mechanically stiff and well-dimensioned shaft systems due to the high current and torque generated during start. DOL starting is uncontrolled, which means that the motor will start with maximum current and torque regardless of load type.



Star-delta

A star-delta starter reduces current and torque during start. The starting current is about one-third compared to direct-on-line starting, although it also reduces the starting torque to about 25 percent. Star-delta is not adjustable, so if the torque is reduced too much, the motor will not start. Current peaks will happen when switching from star to delta connection.

Typical torque, current and voltage curves from starting a motor

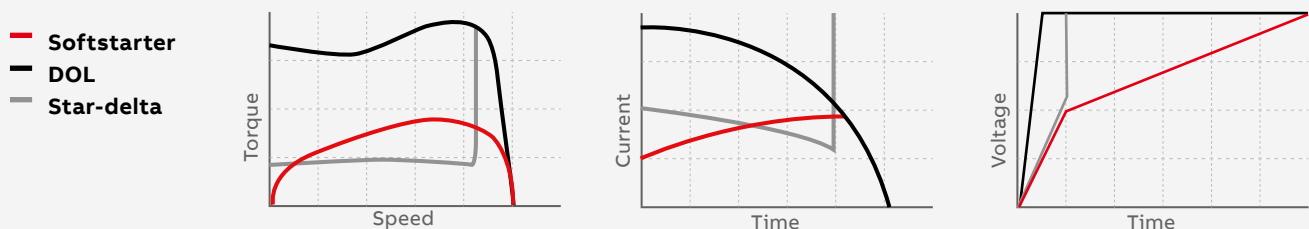



Softstarter

Like direct-on-line and star delta starters, softstarters are used to start and stop motors in full-speed applications. It eliminates common problems associated with motor starting and stopping, including electrical surges, spikes and high inrush currents. Because it offers soft starting and stopping, a softstarter is the optimal compromise between a direct-on-line or star-delta starter and a variable speed drive in many full-speed motor applications.



Variable speed drive

Like a softstarter, a variable speed drive (VSD) can perform soft motor starting and stopping. However, the VSD was designed primarily to control motor speed, resulting in energy-efficient motor operation in variable speed applications. Using a VSD with the sole purpose of ensuring soft starting and stopping of full-speed motors can, therefore, be considered an unnecessarily advanced solution.

Comparison between different starting methods

The table below describes which problems are prevented by using the most common starting methods.

	Direct-on-line DOL	Star-delta start Y/D	Softstarter	Drive
Reduce high inrush current	-	●	●	●
Reduce heavy wear on bearings, shafts, gear boxes, etc.	-	○	●	●
Prevent slipping belts	-	○	●	●
Remove torque/current peaks	-	-	●	●
Prevent water hammering in piping system	-	-	●	●
Need for variable speed control	-	-	-	●

● = standard, ○ = reduced, - = not available

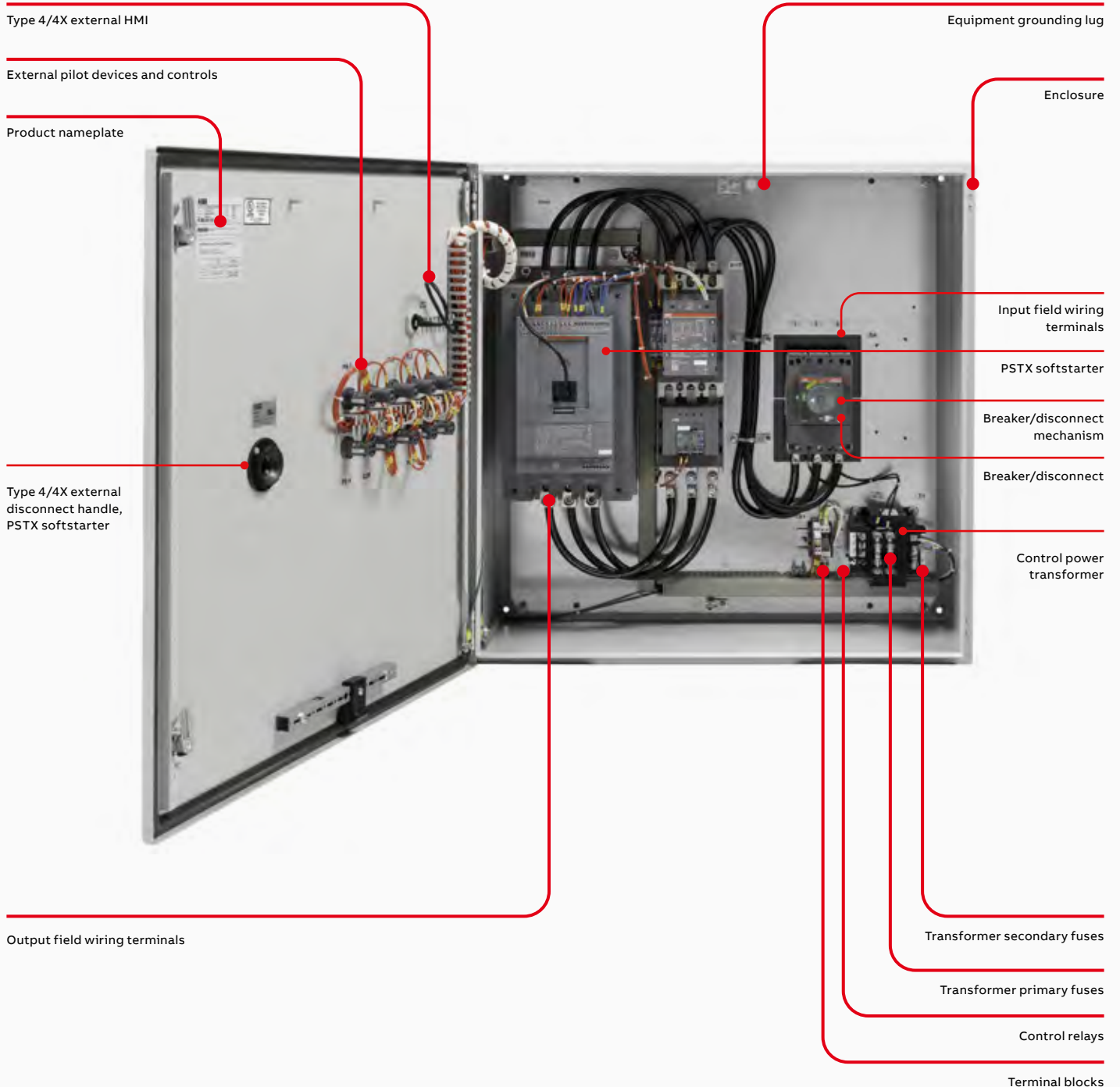

Typical enclosed softstarter components

Overview



Certifications and approvals

The table below shows the certifications and approvals for PSTX enclosed softstarters. For other certifications and/or approvals, please contact ABB.

Certifications for PSTX enclosed softstarters		
Description	Mark	Standard
X-series normal duty (ND) enclosed softstarter		UL 508A, CSA C22.2 No. 286
X-series extreme duty (XD) enclosed softstarter		UL 508A, CSA C22.2 No. 286

Enclosed softstarters

Introduction



+



+



→



SOFTSTARTER BASE UNIT

- PSTX

MULTI-RATED ENCLOSURE

- UL Type 1 / 12 / 3R / 4

ELECTRICAL PROTECTION

- Fused disconnect
- Circuit breaker

ENCLOSED SOLUTION



SECURE
MOTOR

Reliability

COMPLETE INSTALLATION PROTECTION

The enclosed softstarters combine efficient built-in motor protection with industry-tested branch protection and environment protection.

CHOICE OF ELECTRICAL PROTECTION

Multiple available types of protections, from fused disconnects to molded case circuit breakers, fitting your short circuit coordination needs.



IMPROVE
INSTALLATION

Efficiency

TURNKEY SOLUTION

Quick and easy installation with all the parts pre-assembled inside a UL/NEMA-rated cabinet.

DOOR-MOUNTED KEYPAD

A clear, user-friendly display saves you time and resources during both setup and operation. The keypad comes mounted on the cabinet for all enclosed softstarters.



INCREASE
APPLICATION

Productivity

AVOIDING DOWNTIME

With the optional emergency bypass, never lose time on a critical application when experiencing equipment failure. Keep the motor running until scheduled maintenance time.

CUSTOM-ENGINEERED SOLUTION

It is possible to get an engineered enclosed softstarter custom made to suit your application for needs that go beyond the scope of this catalog.

PSTX enclosed softstarters overview

The PSTX combines many years of research and product development with extensive knowledge of application-specific requirements and needs. The PSTX is our latest advancement in motor control and protection and adds new functionality with increased reliability to any motor starting application.

The PSTX offers complete motor protection in only one unit and is able to handle both load and network irregularities. PT-100, earth fault protection, overvoltage and undervoltage protection, along with many other functions, keep your motor safer than ever.

The PSTX offers three types of current limit: standard, dual and ramp. This gives you full control of your motor during start. It also allows you to use your motor in weaker networks.

When reaching full speed, the PSTX will activate its bypass. This saves energy while reducing the softstarter's heat generation. The fact that the softstarter's thyristors are not continuously switching at full speed prolongs the product life, relative to a variable speed drive. On the PSTX, the bypass is built in and verified by ABB, saving you time during installation and space in your panel.

The PSTX features many application-enhancing features, including torque control — the most efficient way to start and stop pumps. The pump cleaning feature can reverse pump flow and clean out pipes, boosting uptime of your pump system.

Main benefits

- Secure motor reliability
- Improve installation efficiency
- Increase application productivity

Main features

- Three-phase controlled
- Operational voltage: 208 to 600 V AC
- Rated operational current: 30...1250 A
- Coated circuit boards
- Torque control for excellent control of pumps
- Integrated control transformer

Standard equipment package additional features*

- Circuit breaker or fused disconnect
- Door-mounted keypad
- Start pushbutton
- Stop pushbutton
- Hand-off-auto selector switch
- Power on pilot light
- Run pilot light
- Fault pilot light
- NEMA 4 enclosure

Full external bypass equipment package features**

- Emergency bypass
- Normal-E-bypass selector switch
- E-bypass start pushbutton
- E-bypass stop pushbutton
- E-bypass pilot light
- Circuit breaker or fused disconnect
- Door-mounted keypad
- Start pushbutton
- Stop pushbutton
- Hand-off-auto selector switch
- Power on pilot light
- Run pilot light
- Fault pilot light
- NEMA 4 enclosure

* Standard on both "ND" and "XD" models.

** "XD" models only.

PSTX softstarter features

Heavy-duty design to handle heavy applications such as centrifugal fan, mill and mixers.

Jog with slow speed forward and reverse

The slow speed forward and backward jog feature will make you more flexible when operating conveyor belts and cranes.

Torque control function provides the best possible stopping of pumps without water hammering or pressure surges.

The HMI is user-friendly with a clear display that saves you time and resources during both setup and operation. The detachable keypad is standard on all PSTX softstarters with IP66 and 4X outdoor rating for tough environments.

Conformal coated electronics protected from dust, moisture and corrosive atmospheres increases the reliability of the softstarter.



Customize your own specific home screens (up to seven different). The PSTX has 17 pre-installed languages. You can use your customized home screens to show status information that's important to your process and hide information that's not.

Detachable keypad as standard. It can be placed externally, avoiding process interruptions to take readings or change settings, while increasing operator safety.

Easy to learn with a large graphical display along with built-in assistants that make learning how to handle the PSTX fun and simple. The interface resembles other interfaces from ABB, which will streamline and help with training of field personnel.

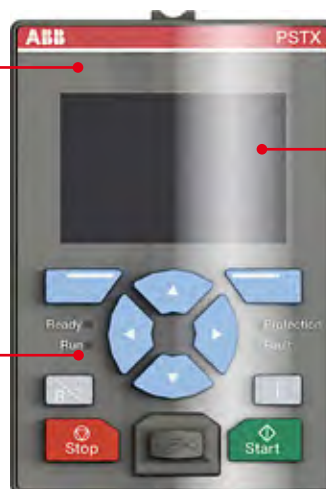

Part numbering convention

PSTX enclosed softstarters follow the part number scheme below:

<horsepower rating code > - < protection type > < enclosure rating code> - < voltage rating code > - < duty type code>

Codification/part number scheme

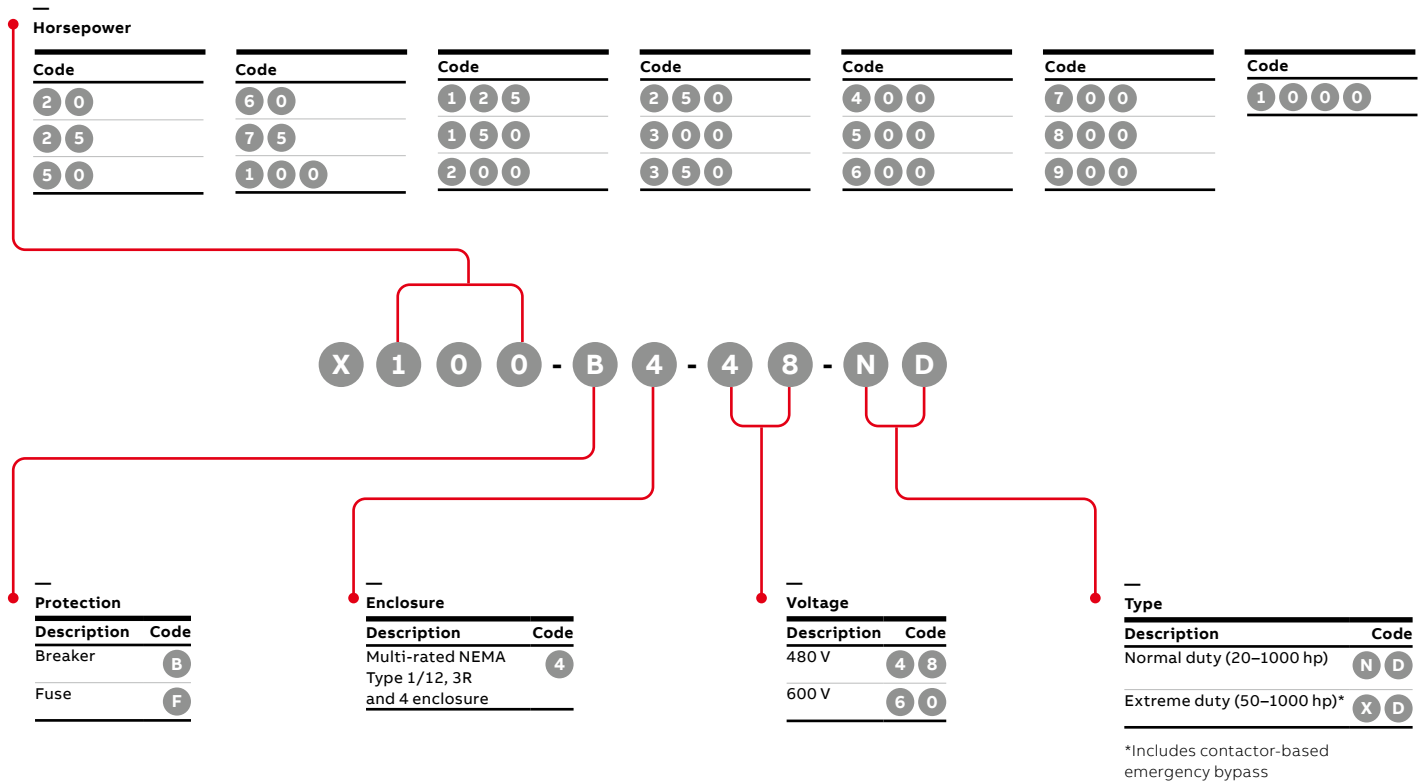

Example: 480 V service voltage, 100 horsepower, normal duty, Type 4 multi-rated enclosure with molded case circuit breaker for protection = X100-B4-48-ND

Ordering details

Normal duty (ND), 480 V



Door-mounted pilot devices include:

- PSTX keypad
- Hand-off-auto selector switch
- Start and stop pushbuttons
- Power on pilot light
- Run pilot light
- Fault pilot light

Typical normal-duty applications include:

- Belt thruster
- Centrifugal pump
- Compressor
- Conveyor belt (short)
- Elevator

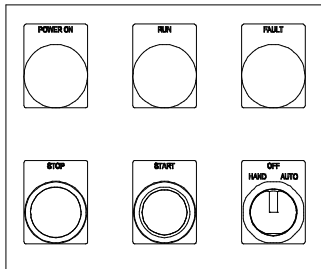

Detail A

Normal duty (ND) — 480 V, 3-phase with molded case circuit breaker protection

Normal-duty class 10 starts hp	Heavy-duty class 30 starts hp	Rated operational current A	SCCR rating kA	Type	Order code	Enclosure size H x W x D in
20	15	28	65	X20-B4-48-ND	3AUA0000224500	24x20x12
50	40	68	65	X50-B4-48-ND	3AUA0000224501	24x20x12
75	60	104	65	X75-B4-48-ND	3AUA0000224502	24x20x12
100	75	130	65	X100-B4-48-ND	3AUA0000224503	30x30x12
125	100	169	65	X125-B4-48-ND	3AUA0000224504	30x30x12
150	125	192	65	X150-B4-48-ND	3AUA0000224505	48x36x16
200	150	248	65	X200-B4-48-ND	3AUA0000224506	48x36x16
250	200	302	65	X250-B4-48-ND	3AUA0000224507	48x36x16
300	250	361	65	X300-B4-48-ND	3AUA0000224508	48x36x16
400	300	480	65	X400-B4-48-ND	3AUA0000224509	48x36x16
500	400	590	65	X500-B4-48-ND	3AUA0000224510	48x36x16
600	500	720	65	X600-B4-48-ND	3AUA0000224511	72x36x24 ¹
700	600	840	65	X700-B4-48-ND	3AUA0000224512	91x36x24 ¹

¹ Free-standing enclosure

² Includes pedestal base for floor mounting

³ Fused disconnect model only

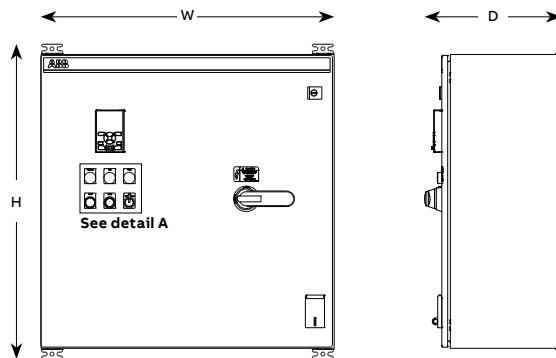

Ordering details

Normal duty (ND), 600 V

Normal duty (ND) — 600 V, 3-phase with fused disconnect

Normal-duty class 10 starts hp	Heavy-duty class 30 starts hp	Rated operational current A	SCCR rating kA	Type	Order code	Enclosure size H x W x D in
25	20	27	65	X25-F4-60-ND	1SQA013218R0001	24x20x12
50	40	52	65	X50-F4-60-ND	1SQA013219R0001	24x20x12
60	50	62	65	X60-F4-60-ND	1SQA013220R0001	24x20x12
75	60	77	65	X75-F4-60-ND	1SQA013221R0001	24x20x12
100	75	99	65	X100-F4-60-ND	1SQA013225R0001	24x20x12
125	100	125	65	X125-F4-60-ND	1SQA013222R0001	30x30x12
150	125	144	65	X150-F4-60-ND	1SQA013226R0001	30x30x12
200	150	192	65	X200-F4-60-ND	1SQA013227R0001	48x36x16
250	200	242	65	X250-F4-60-ND	1SQA013223R0001	48x36x16
300	250	289	65	X300-F4-60-ND	1SQA013228R0001	48x36x16
350	300	336	65	X350-F4-60-ND	1SQA013224R0001	48x36x16
500	350	472	65	X500-F4-60-ND	1SQA013229R0001	48x36x16
600	500	590	65	X600-F4-60-ND	1SQA013230R0001	72x36x24 ¹
700	600	720	65	X700-F4-60-ND	1SQA013231R0001	91x36x24 ¹
800	700	840	65	X800-F4-60-ND	1SQA013232R0001	91x36x24 ¹

¹ Free-standing enclosure

² Includes pedestal base for floor mounting

Ordering details

Extreme duty (XD) with full external bypass



Door-mounted pilot devices include:

- PSTX keypad
- Hand-off-auto selector switch
- Start and stop pushbuttons
- Power on pilot light
- Run pilot light
- Fault pilot light
- Normal/E-bypass selector switch
- E-bypass start and stop pushbuttons
- E-bypass pilot light

Typical heavy-duty applications include:

- Centrifugal fan
- Conveyor belt (long)
- Crusher
- Mill
- Mixer
- Stirrer

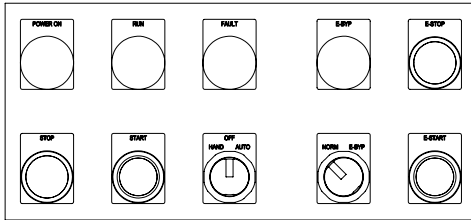

Detail A

Extreme duty (XD) — 480 V, 3-phase with molded case circuit breaker protection

Normal-duty class 10 starts hp	Heavy-duty class 30 starts hp	Rated operational current A	SCCR rating kA	Type	Order code	Enclosure size H x W x D in
60	50	65	65	X50-B4-48-XD	3AUA0000226360	24x20x12
100	75	96	65	X75-B4-48-XD	3AUA0000226361	30x30x12
125	100	124	65	X100-B4-48-XD	3AUA0000226362	30x30x12
150	125	156	65	X125-B4-48-XD	3AUA0000226363	48x36x16
200	150	180	65	X150-B4-48-XD	3AUA0000226364	48x36x16
250	200	240	65	X200-B4-48-XD	3AUA0000226365	48x36x16
300	250	302	65	X250-B4-48-XD	3AUA0000226366	48x36x16
400	300	361	65	X300-B4-48-XD	3AUA0000226367	72x36x24 ¹
500	400	477	65	X400-B4-48-XD	3AUA0000226368	72x36x24 ¹
600	500	590	65	X500-B4-48-XD	3AUA0000226369	72x36x24 ¹
700	600	720	65	X600-B4-48-XD	3AUA0000228980	85x72x24 ^{1,2}

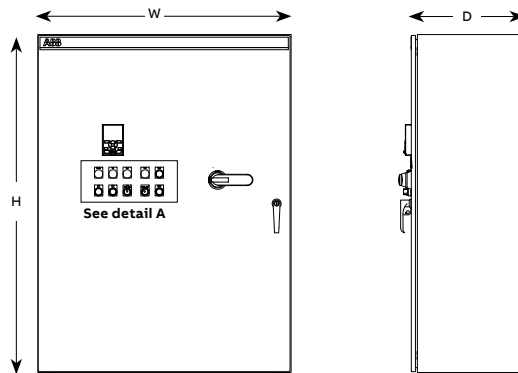

PSTX enclosed softstarters — The advanced range

Technical data

Comply with UL 508A and CSA22.2 No. 286 standards
Enclosure NEMA type 1, 12, 3R and 4

Technical data	X20...X1000
Rated insulation voltage U _i	690 V
Rated operational voltage U _e	208...600 V, +10%/-15%, 50/60 Hz ±10%
Rated control supply voltage U _S	100...250 V +10%/-15%, 50/60 Hz ±10%
Rated control circuit voltage U _C	Internal or external 24 V DC
Starting capacity at I _e	4 x I _e for 10 sec.
Number of starts per hour	10 for PSTX20...PSTX250 ¹ 6 for X300...X1000 ¹
Overload capability	Overload class 10
Maximum altitude	4000 m (13,123 ft) ³
Ambient temperature	
During operation	-25...40 °C (-13...104 °F) ²
During storage	-40...+70 °C (-40...+158 °F)
Degree of protection	
Main circuit	–
Supply and control circuit	IP20
Enclosure	UL Type 1, 12, 3R, 4
Main circuit	
Built-in bypass contactor	Yes
Cooling system – fan cooled	Yes (thermostat-controlled)
HMI (human machine interface) for settings	
Display	LCD type, graphical
Languages	Arabic, Chinese, Czech, Dutch, English, Finnish, French, German, Greek, Indonesian, Italian, Polish, Portuguese, Russian, Spanish, Swedish and Turkish
Keypad	2 selection keys, 4 navigation keys, start key, stop key, info key and remote/local key
Signal relays	
Number of programmable signal relays	3 (each relay can be programmed to None, Run, Top of ramp, Event group 0–6, Sequence 1–3 Run, Sequence 1–3 Top of ramp or Run reverse)
K4	Default as Run signal
K5	Default as Top of Ramp (Bypass) signal
K6	Default as Event group 0 (Faults)
Rated operational voltage, U _e	250 V AC/24 V DC
Rated thermal current I _{th}	5 A
Rated operational current I _e at AC-15 (U _e =250 V)	1.5 A
Analog output	
Output signal reference	0...10 V, 0...10 mA, 0...20 mA, 4...20 mA
Type of output signal	Motor current (A), Main voltage (V), Active power (kW), Active power (HP), Reactive power (kVAR), Apparent power (kVArh), Active energy (kWh), Reactive energy (kVArh), cos phi, Motor temperature (%), Thyristor temperature (%), Motor voltage (%), Main frequency (Hz), PT100 temperature (centigrade), PTC resistance (ohms)

Control circuit	
Number of inputs	2 (start, stop)
Number of additional programmable inputs	3 (each input can be programmed to: None, Reset, Enable, Slow speed forward (Jog), Slow speed reverse (Jog), Motor heating, Stand still brake, Start reverse, User defined protection, Emergency mode (active high), Emergency mode (active low), Fieldbus disable control, Start 1, Start 2, Start 3, Switch to remote control or Cancel brake)
Signaling indication LED	
Ready	Green
Run	Green
Fault	Red
Protection	Yellow
External keypad	
Detachable keypad	Yes (externally mounted)
Display	LCD type, graphical
Ambient temperature	
During operation	-25...+60 °C (-13...+140 °F)
During storage	-40...+70 °C (-40...+158 °F)
Degree of protection	IP66 (Type 1, 4X, 12)
Start and stop functions	
Soft start with voltage ramp	Linear voltage ramp, suitable for most applications
Soft stop with voltage ramp	Used to prolong the stop sequence
Soft start with torque control	Linear torque ramp, the best way to start pumps
Soft stop with torque control	Commonly used to reduce water hammering in pumps
Kick start	More power in the start for heavy-duty applications.
Full voltage start	0.5 second start ramp for applications with need of high starting torque
Sequence start	Start multiple motors with one softstarter
Current limit	Limits the current below a specified value
Dual current limit	Consist of a low level, a high level and a time between them
Current limit ramp	A linear increase of the current from the low to the high level
Torque limit	Limit the torque to between 20-200%
Pre-start function	Use Motor heating, Stand still brake or Jog automatically prior to start ramp
Jog with slow speed, forward and reverse	Run the motor in three different speeds, both forward and reverse
Start reverse (external contactors)	Internal logic that allows control of external contactors for reverse start
Dynamic brake	Provides a braking force to decrease stop time

¹ Valid for normal start (class 10) for 50% on time and 50% off time. If other data is required, contact your local ABB office.

² Above 40 °C (104 °F) up to max. 60 °C (140 °F) reduce the rated current with .8% per °C (0.44% per °F).

³ When used at high altitudes, above 1000 meters (3281 ft) up to 4000 meters (13123 ft), de-rate the rated current using the following formula.

$$[\% \text{ of } I_e = 100 - \frac{x-1000}{100}] \times \text{actual altitude of the softstarter in meter, } [\% \text{ of } I_e = 100 - \frac{x-3280}{497}] \times \text{actual altitude of the softstarter in feet. For de-rating of voltage, contact ABB.}$$

PSTX enclosed softstarters — The advanced range

Technical data

Fieldbus connection	
Built-in Modbus RTU	Yes, with RS485 interface on terminals 23 and 24
Connection for Anybus	Yes, including most common protocols, see open-type catalog for details
Connection for ABB Fieldbus plug	Yes, compatible with a special adapter, see open-type catalog for details
Protections	
Electronic overload protection, EOL	User-defined, class 10A, 10, 20, 30
Dual overload (separate overload for start and run)	Possible to set separate overloads for start and full speed
PTC connection	User-defined temperature control with external PTC sensor
PT-100 connection	User-defined temperature control with external PT-100 sensor
Locked rotor protection	Prevents start if motor is stuck, e.g., stuck pumps and conveyors
Current underload protection	Stops the process if the load is too light, e.g., a pump running dry
Current imbalance protection	User-defined, checks current imbalance between the phases
Power factor underload protection	User-defined, trip if power factor is out of range
Under-voltage protection	User-defined, prevents the motor from stalling in weak networks
Over-voltage protection	User-defined, prevents the motor from damage at high voltage levels
Voltage imbalance protection	User-defined, checks voltage imbalance between the phases
Earth fault protection/ground fault protection	User-defined, 0.1–1.0 sec, stops process if earth fault is detected
Phase reversal protection	Prevents start if phases are connected in the wrong order
Bypass open protection	Trips if the bypass is open when it should be closed
User-defined protection	Programmable input, can be used with external protection device
Too long current limit protection	User-defined, trips when the current has been at the current limit for too long
HMI failure protection	Indicates communication failure between softstarter and HMI
Fieldbus failure protection	Indicates communication failure between softstarter and PLC
Extension IO failure protection	Indicates communication failure between softstarter and IO module
Max. number of starts/hour	Prevents start if the thyristors gets too warm (thus used over specification)
Too long start time protection	User-defined, trips when the starting time exceeds a set value
External faults detection	
Phase loss	Yes
Hight current	Yes
Low control supply voltage	Yes
Faulty usage	Yes, e.g., using limp mode inside-delta
Faulty connection	Yes
Bad network quality	Yes
Vibration test	
PSTX softstarter only (not UL 508A assembly)	

Warnings	
Current underload warning	User-defined on/off
Current imbalance warning	User-defined on/off
Voltage imbalance warning	User-defined on/off
Thyristor overload warning (SCR)	User-defined on/off
Electronic overload time-to-trip (for limp mode)	User-defined on/off
Short circuit warning	User-defined on/off, for limp mode
Over-voltage warning	User-defined on/off
Under-voltage warning	User-defined on/off
Power factor underload warning	User-defined on/off
Locked rotor warning	User-defined on/off
Faulty fan warning	User-defined on/off
THD(U) — total harmonic distortion warning	User-defined on/off
Motor runtime limit warning	User-defined on/off
Phase loss warning (for standby)	User-defined on/off, for standby
EOL warning	User-defined on/off
Internal faults detection	
Thyristor overload	Yes
Short circuit	Yes
Open circuit thyristor or gate	Yes
Heat sink over temperature	Yes
Shunt fault	Yes
PTC input	
Switch off resistance	2825 ohms ± 20%
Switch on resistance	1200 ohms ± 20%
Other functions	
Real-time clock	Can maintain time when the softstarter isn't powered up, 48 hr. back-up
Event log	Log of events such as trips, parameters changed and operation
Emergency mode	To keep the softstarter running regardless of trip or failure; activated via DI
Automatic restart	In case of trip and stopped motor, the softstarter can restart itself
Keypad password	Lock the keypad to inhibit unauthorized motor control
Pump cleaning	Can reverse pump flow and clean out pipes
Electronic overload time-to-cool	Time until the motor is ready to be restarted after an EOL trip
Thyristor runtime measurement	Measures most electrical variables, e.g., voltage, current and power
Auto phase sequence detection	Detection of the phase sequence
Electricity metering	Measures most electrical variables, e.g., voltage, current and power
Motor heating	DC injection in all windings to heat up the motor; useful in cold or humid environment
Stand still brake	Prevents the motor from moving, useful to keep fans from reversing
Voltage sags detection	User-defined
Limp mode with two-phase motor control if one set of thyristors is shorted	Can keep process running until planned maintenance

For all functions and features, see installation and commissioning manual, available on [solutions.abb/softstarters](#)

PSTX enclosed softstarters

Dimensions

X20-B4-48-ND, X50-B4-48-ND, X75-B4-48-ND

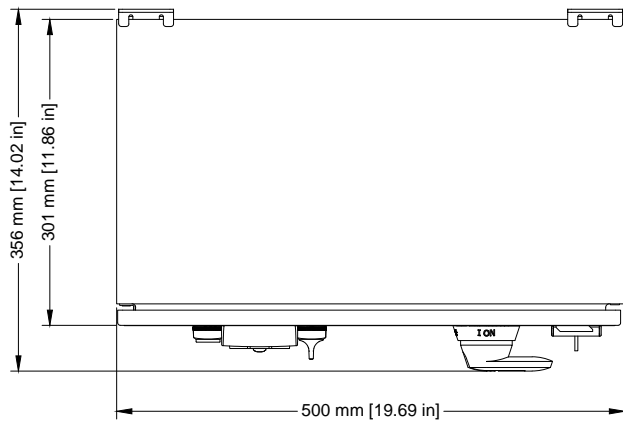

TOP VIEW
SCALE 1 / 6

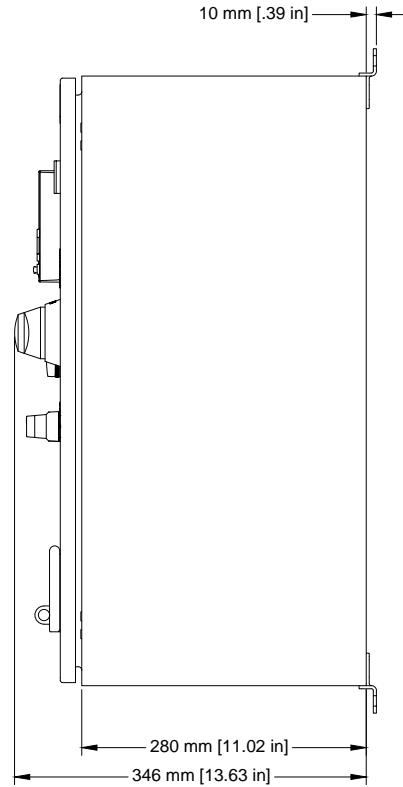

SIDE VIEW
SCALE 1 / 6

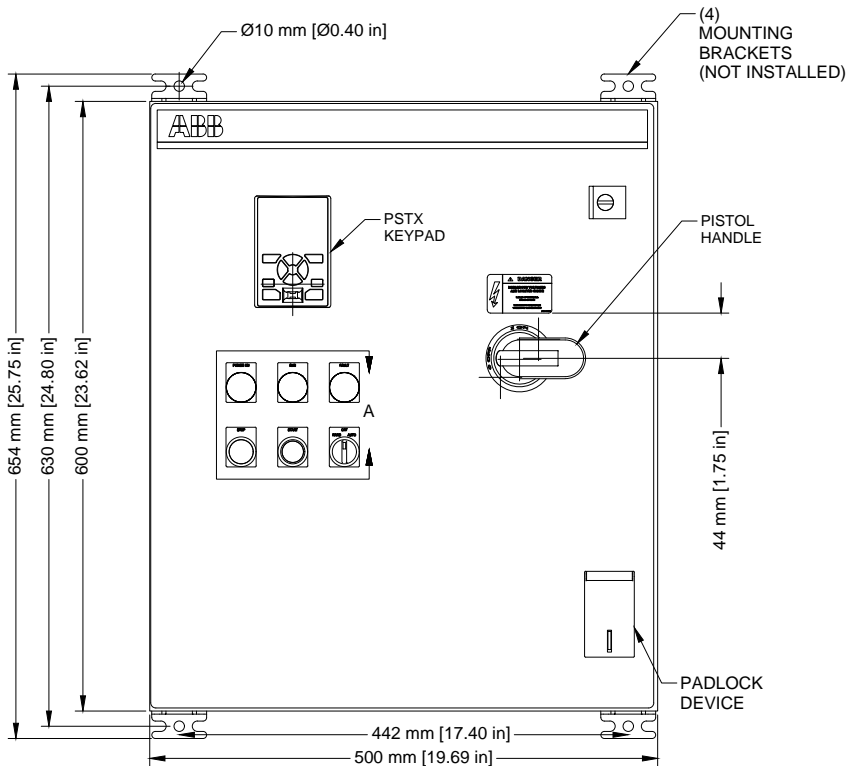

FRONT VIEW
SCALE 1 / 6

PSTX enclosed softstarters

Dimensions

X100-B4-48-ND, X125-B4-48-ND

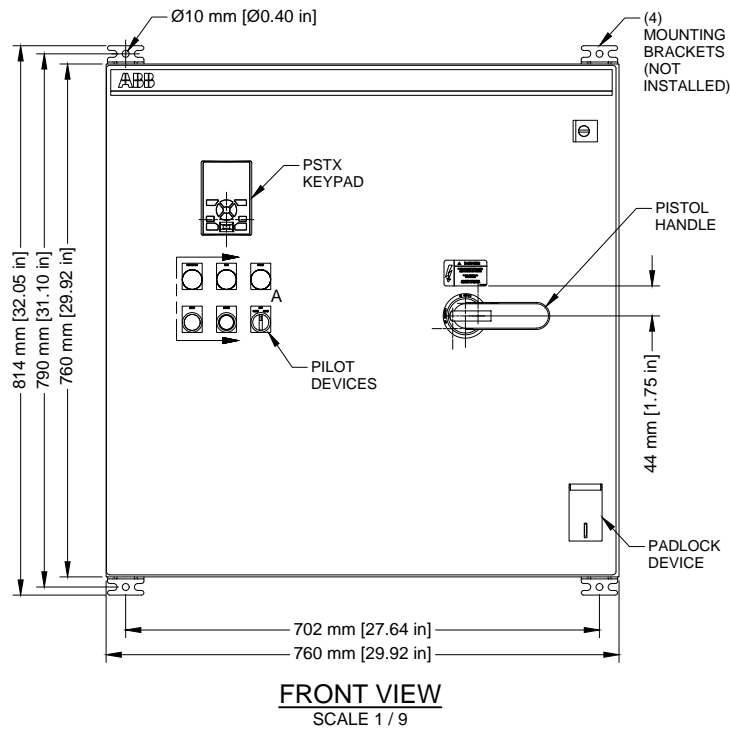
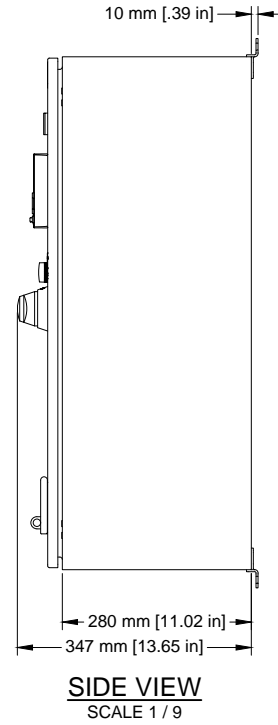
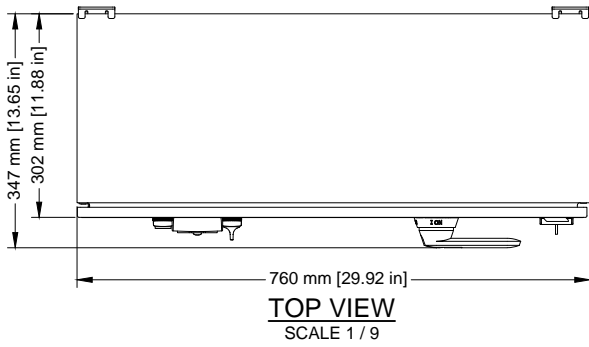

PSTX enclosed softstarters

Dimensions

X150-B4-48-ND, X200-B4-48-ND

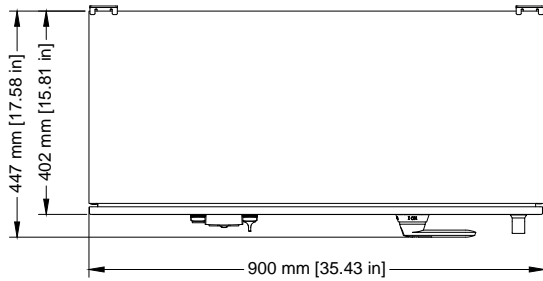

TOP VIEW
SCALE 1 / 12

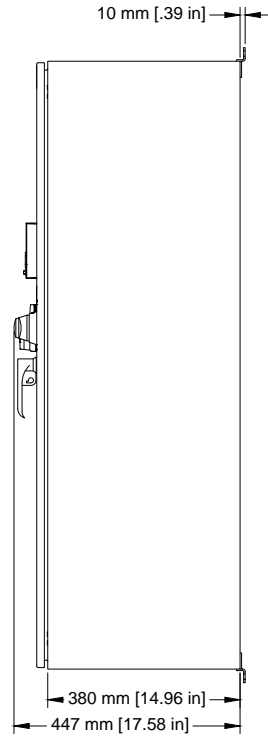

SIDE VIEW
SCALE 1 / 12

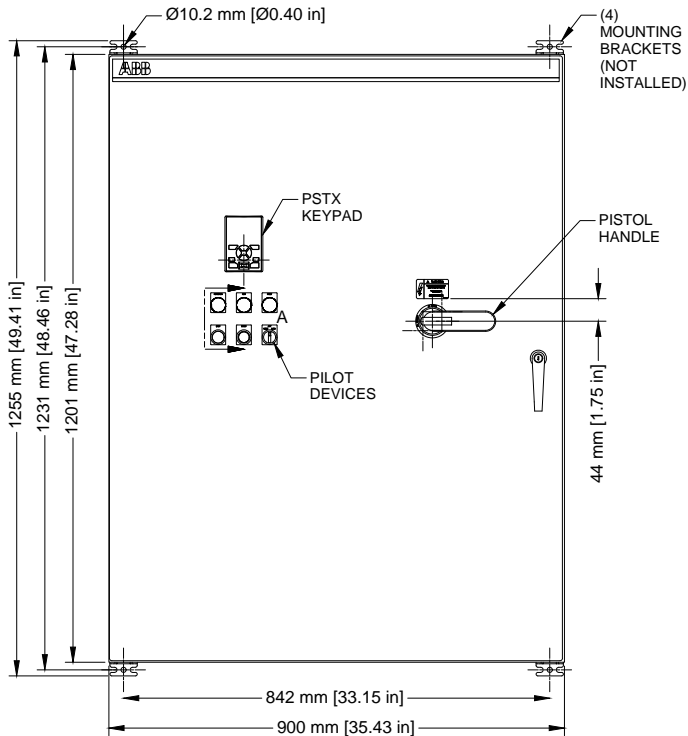

FRONT VIEW
SCALE 1 / 12

PSTX enclosed softstarters

Dimensions

X250-B4-48-ND, X300-B4-48-ND

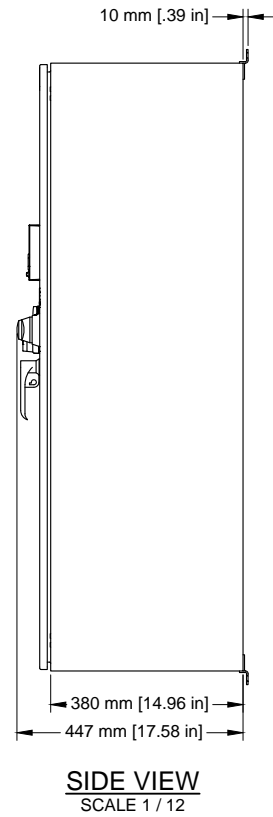
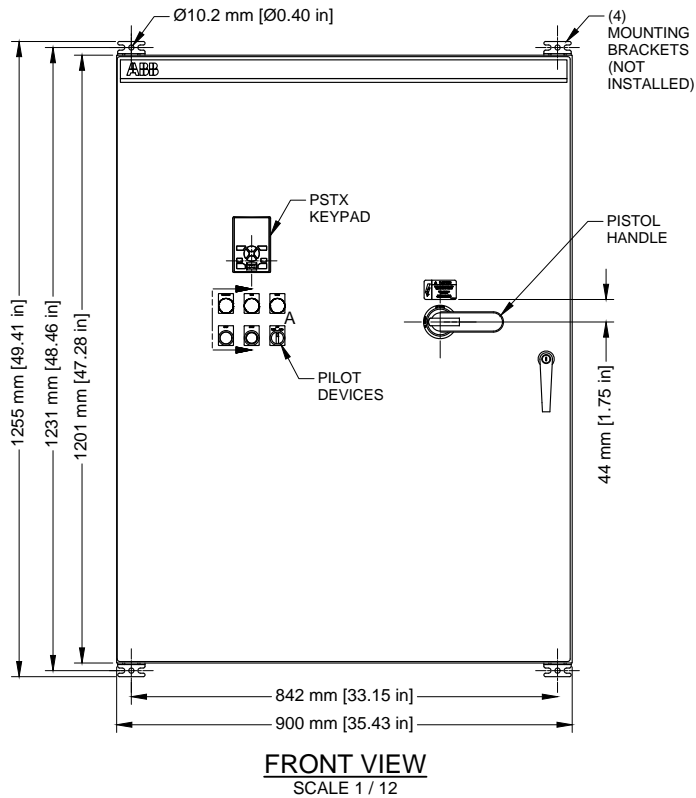
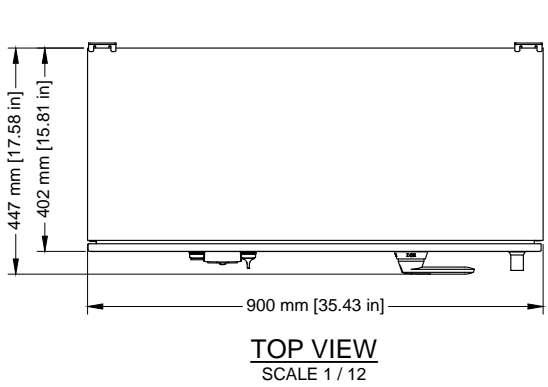

PSTX enclosed softstarters

Dimensions

X400-B4-48-ND

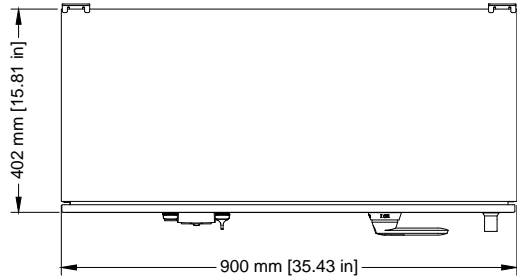

TOP VIEW
SCALE 1 / 12

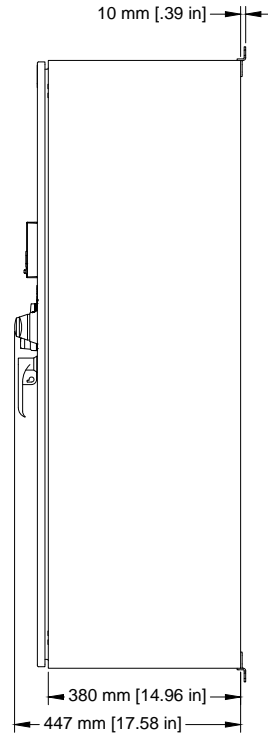

SIDE VIEW
SCALE 1 / 12

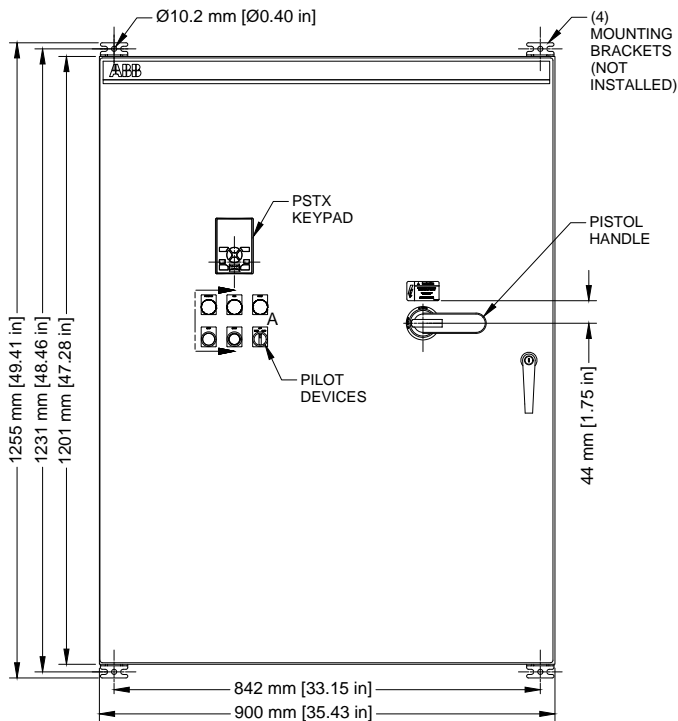

FRONT VIEW
SCALE 1 / 12

PSTX enclosed softstarters

Dimensions

X500-B4-48-ND

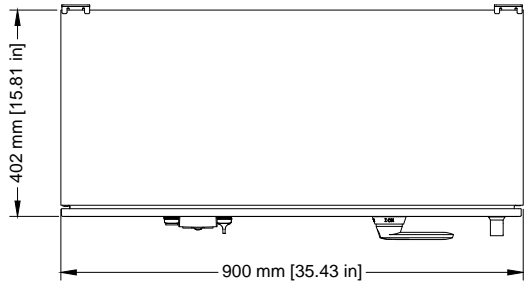

TOP VIEW
SCALE 1 / 12

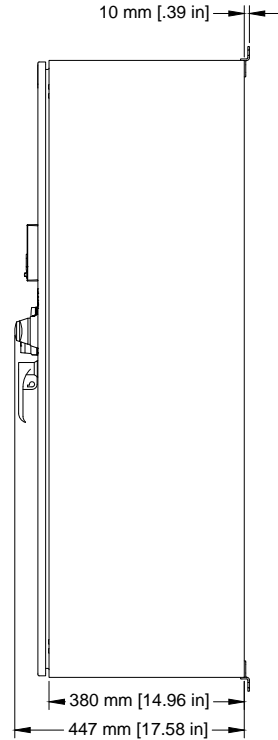

SIDE VIEW
SCALE 1 / 12

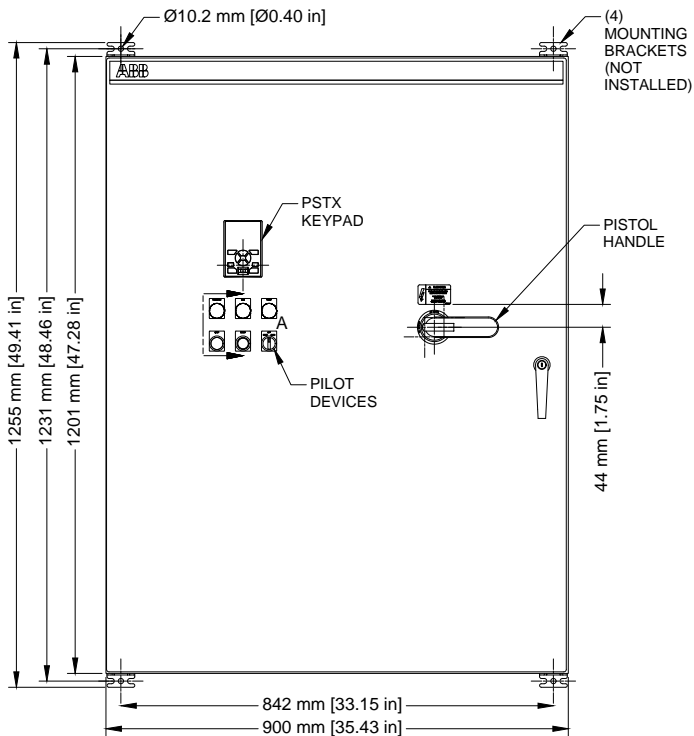

FRONT VIEW
SCALE 1 / 12

PSTX enclosed softstarters

Dimensions

X600-B4-48-ND

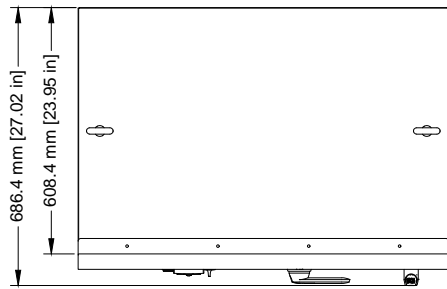

TOP VIEW
SCALE 1 / 15

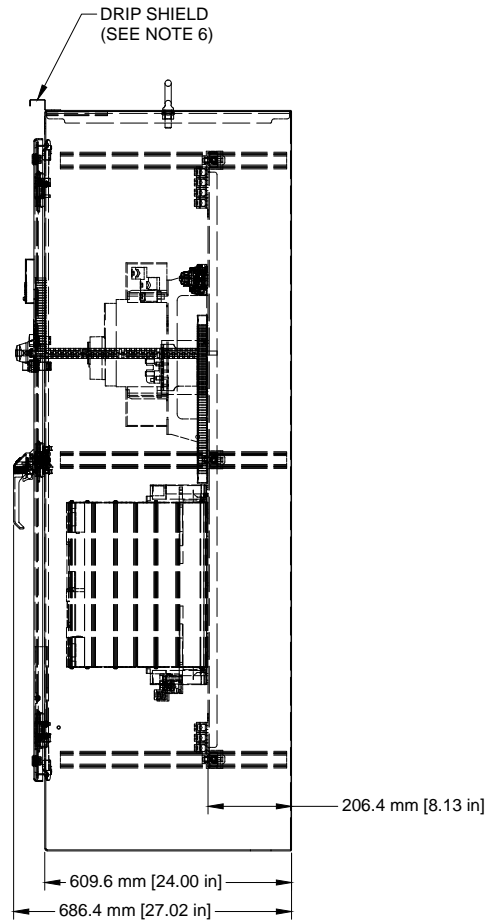

SIDE VIEW
SCALE 1 / 15

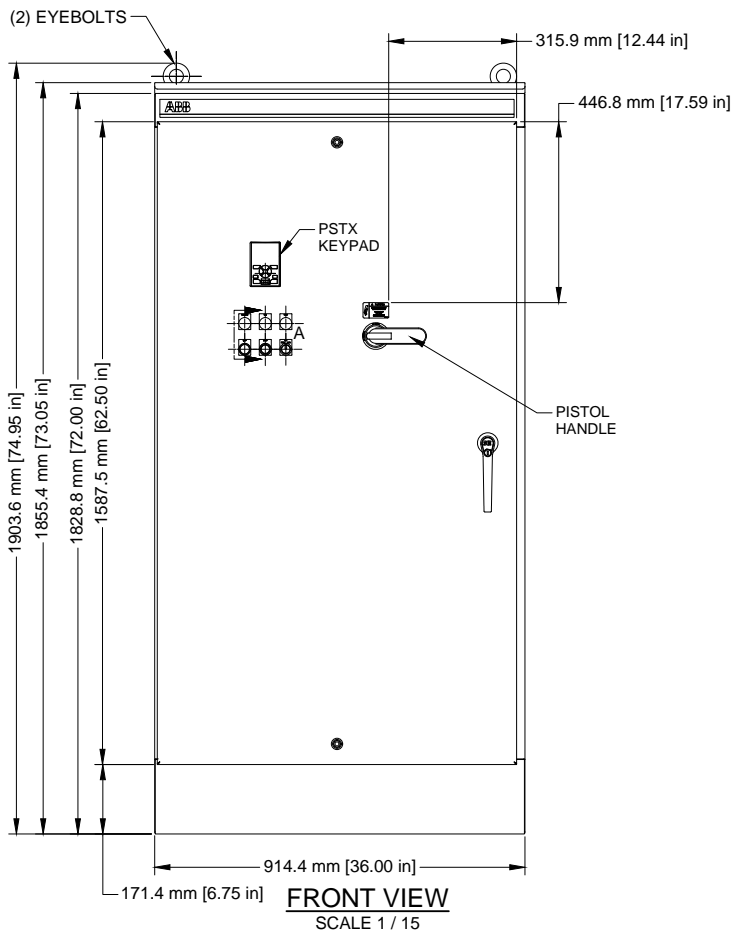

FRONT VIEW
SCALE 1 / 15

PSTX enclosed softstarters

Dimensions

X700-B4-48-ND

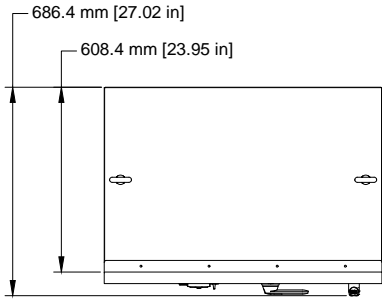

TOP VIEW
SCALE 1 / 20

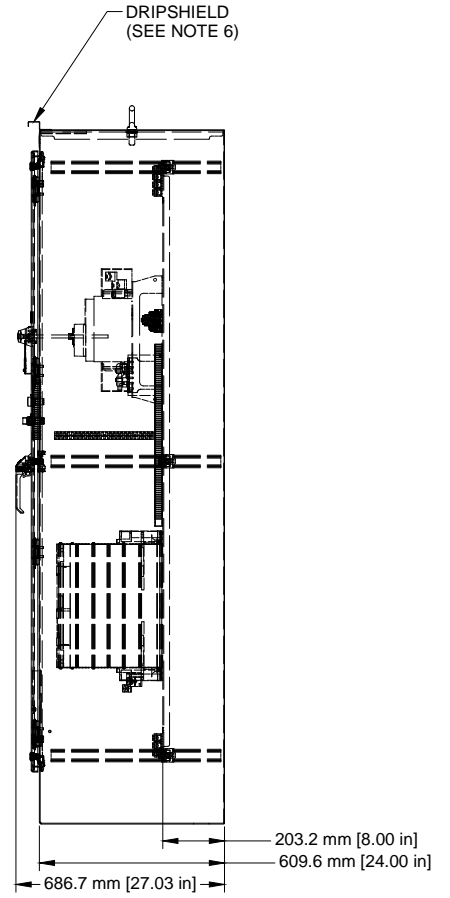

SIDE VIEW
SCALE 1 / 20

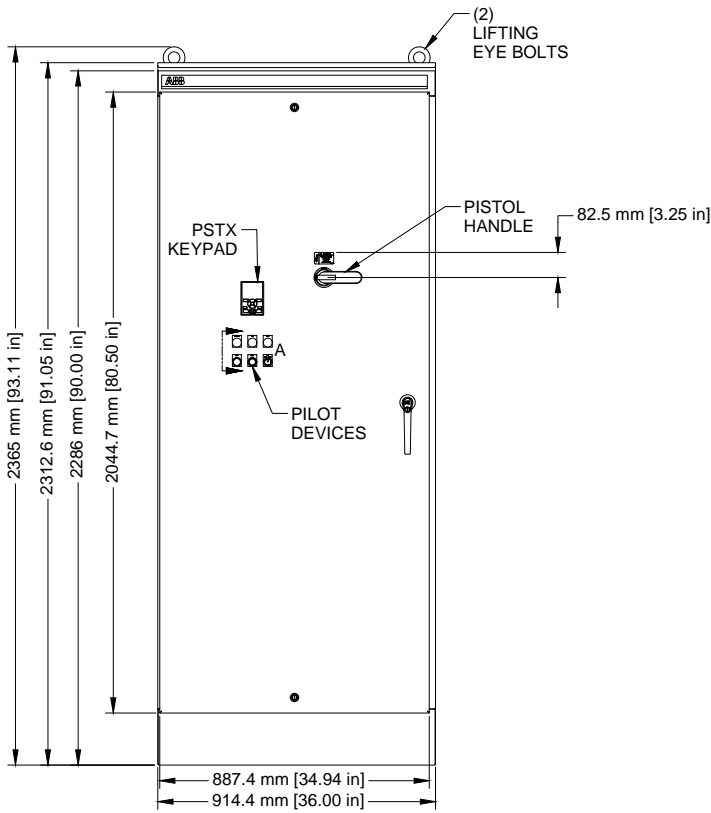

FRONT VIEW
SCALE 1 / 20

PSTX enclosed softstarters

Dimensions

X25-F4-60-ND

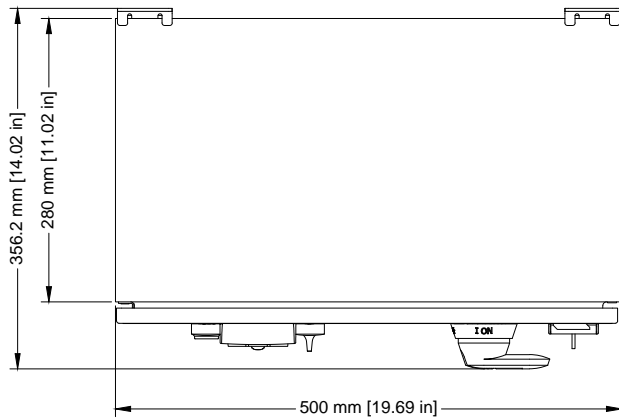

TOP VIEW
SCALE 1 / 6

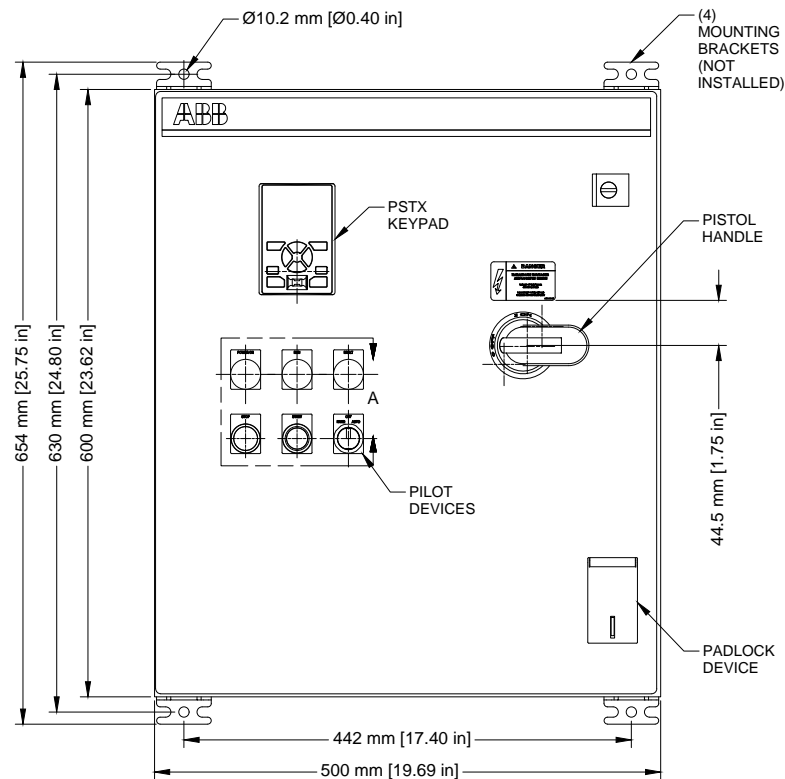

FRONT VIEW
SCALE 1 / 6

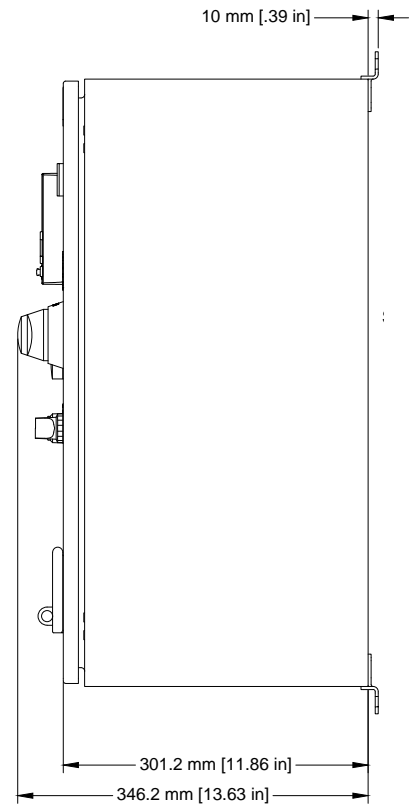

SIDE VIEW
SCALE 1 / 6

PSTX enclosed softstarters

Dimensions

X50-F4-60-ND, X60-F4-60-ND

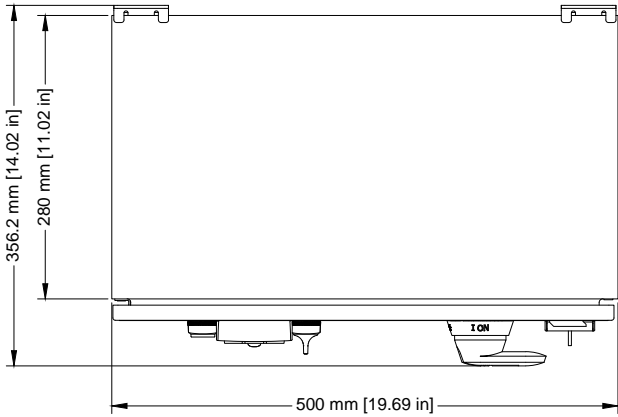

TOP VIEW
SCALE 1 / 6

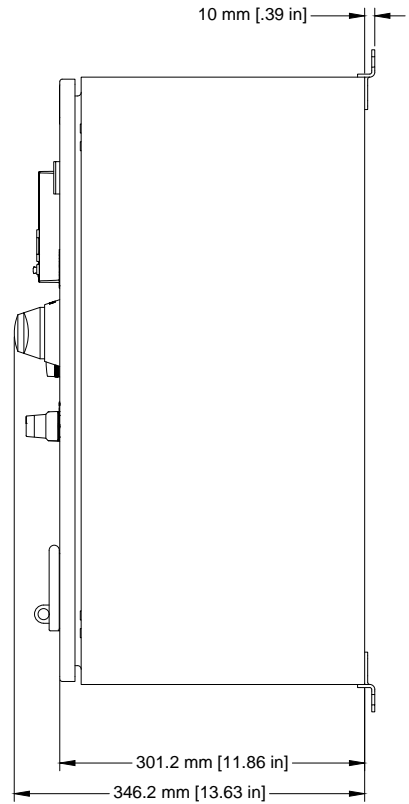

SIDE VIEW
SCALE 1 / 6

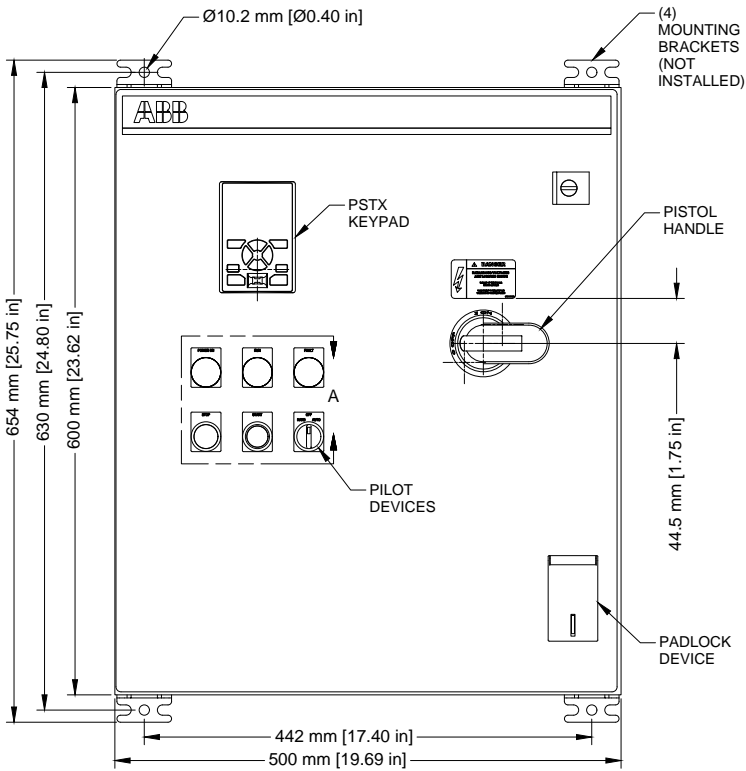

FRONT VIEW
SCALE 1 / 6

PSTX enclosed softstarters

Dimensions

X75-F4-60-ND, X100-F4-60-ND

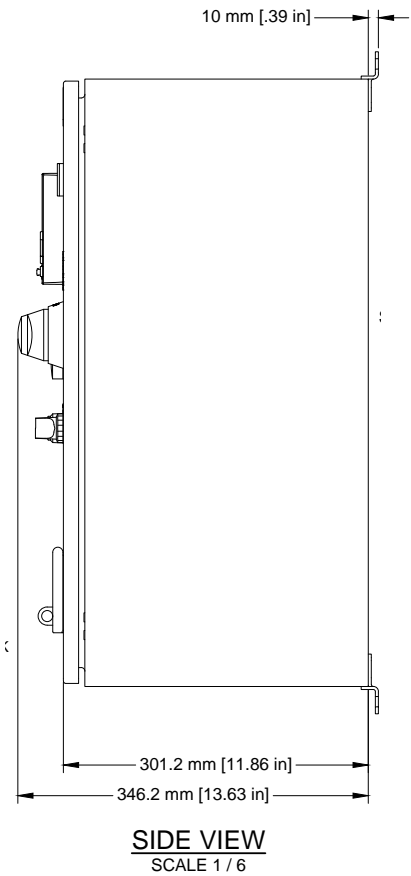
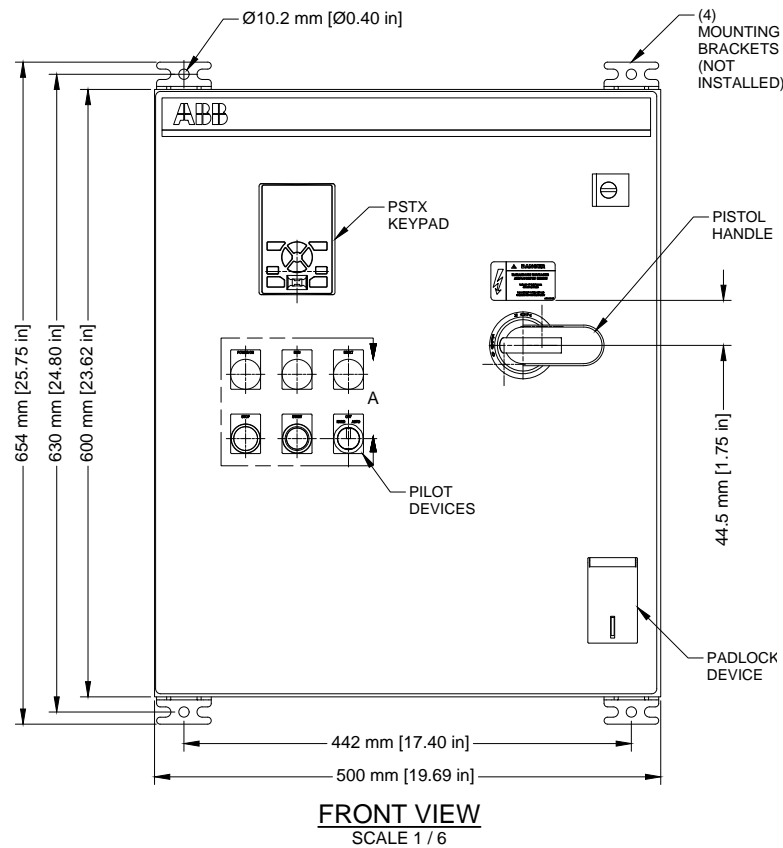
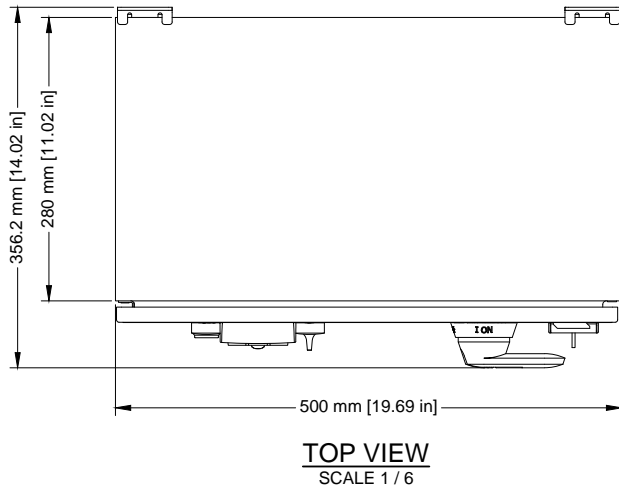

PSTX enclosed softstarters

Dimensions

X125-F4-60-ND

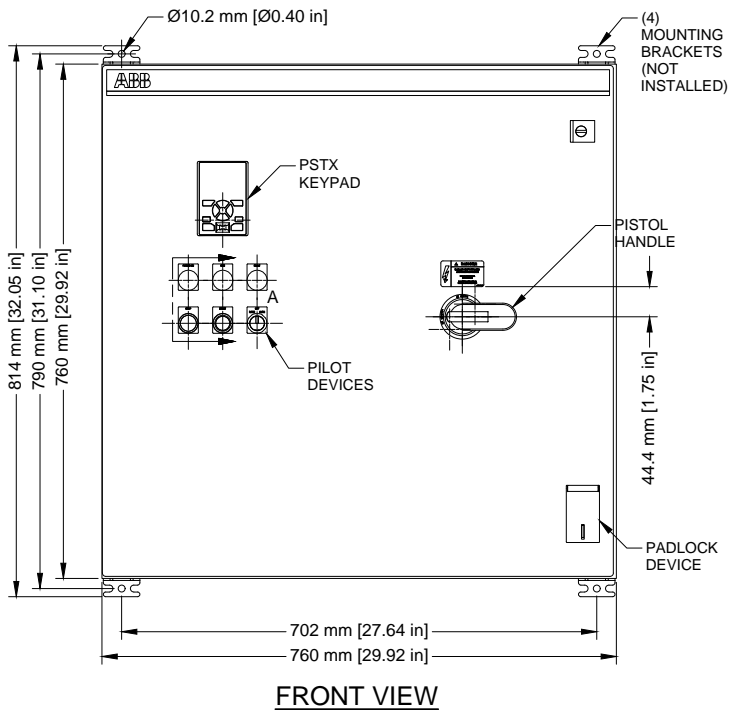
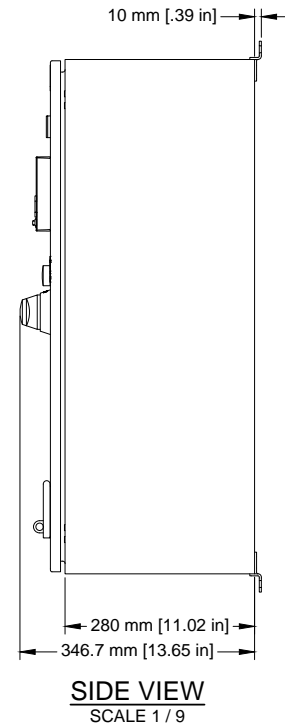
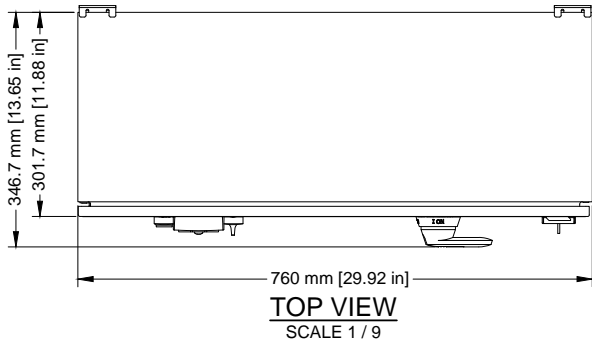

PSTX enclosed softstarters

Dimensions

X150-F4-60-ND

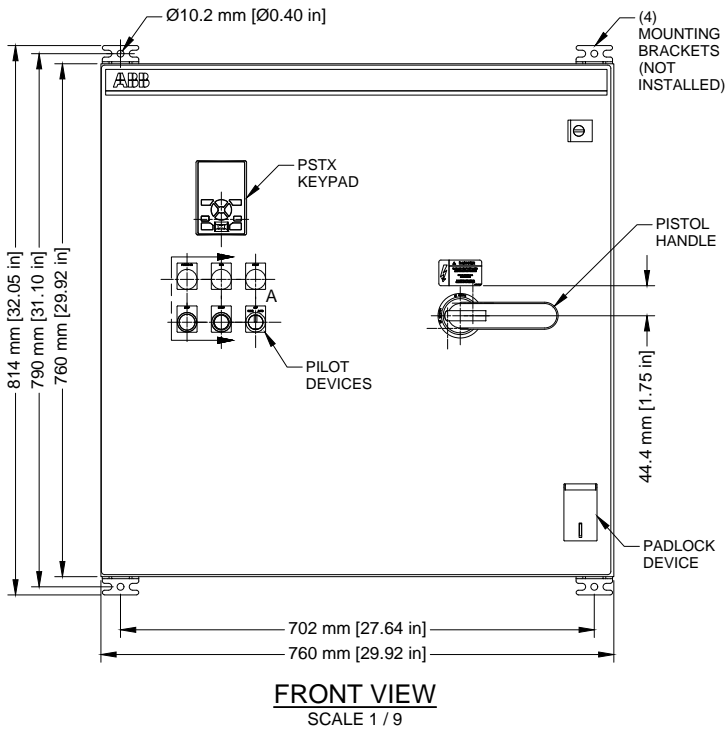
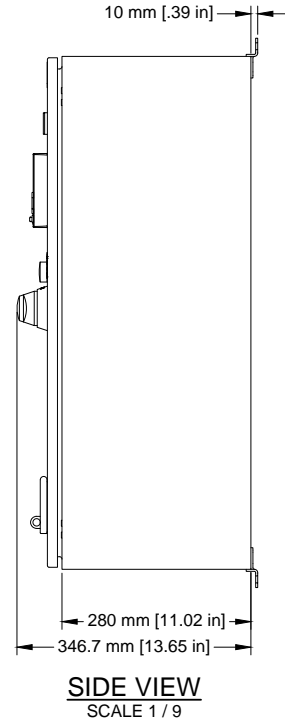
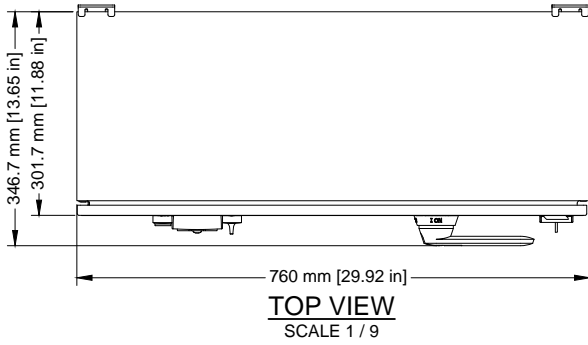

PSTX enclosed softstarters

Dimensions

X200-F4-60-ND, X250-F4-60-ND

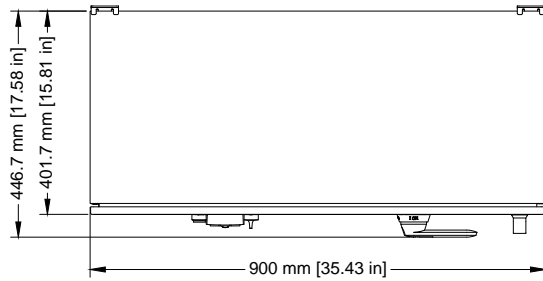

TOP VIEW
SCALE 1 / 12

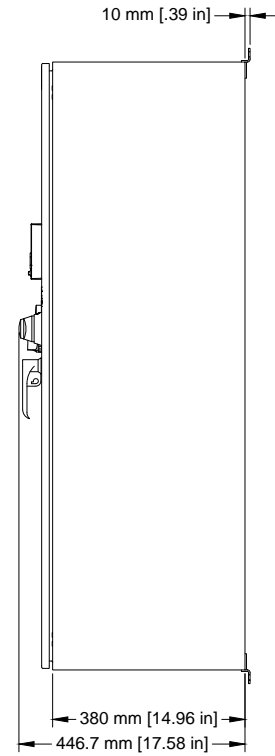

SIDE VIEW
SCALE 1 / 12

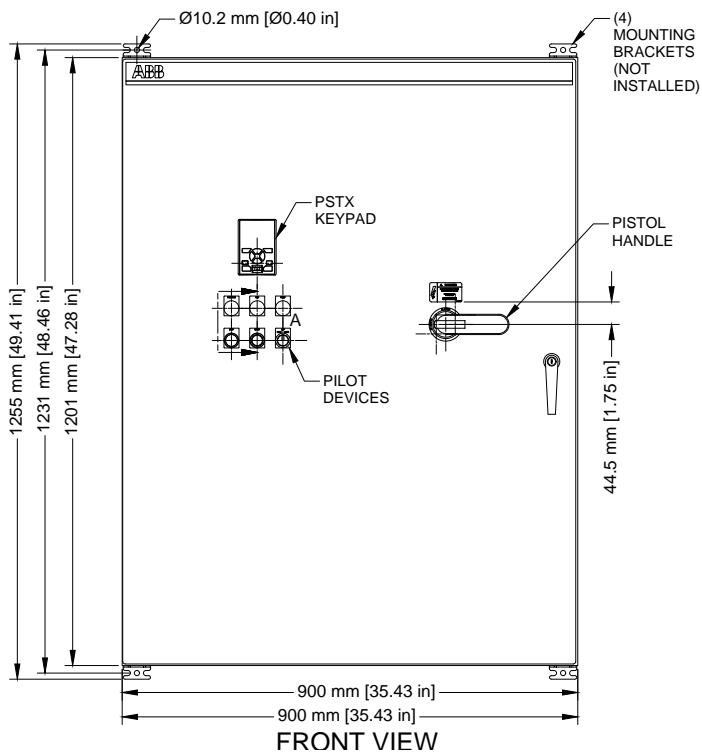

FRONT VIEW

PSTX enclosed softstarters

Dimensions

X300-F4-60-ND, X350-F4-60-ND

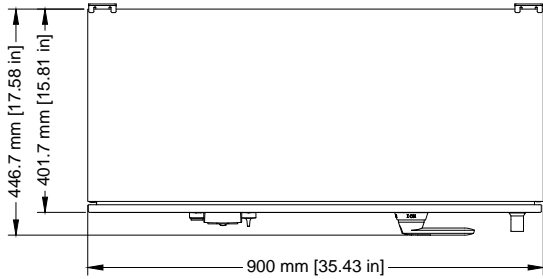

TOP VIEW
SCALE 1 / 12

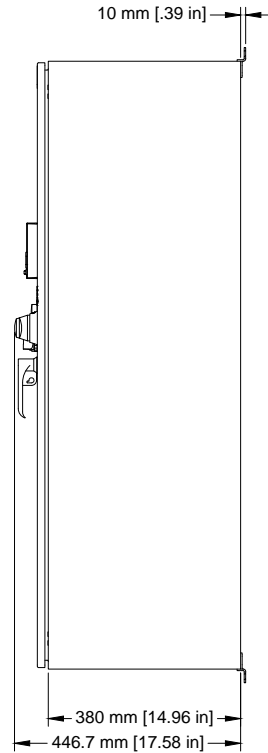

SIDE VIEW

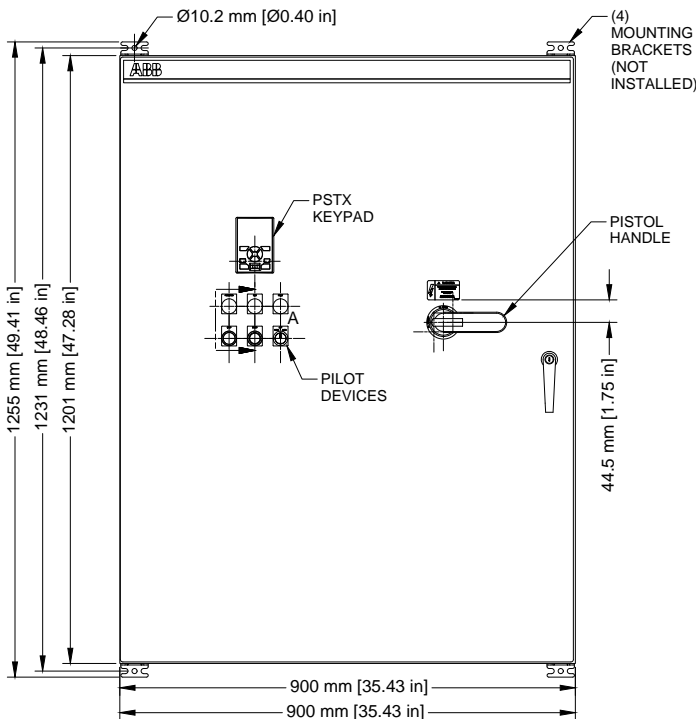

FRONT VIEW
SCALE 1 / 12

PSTX enclosed softstarters

Dimensions

X500-F4-60-ND

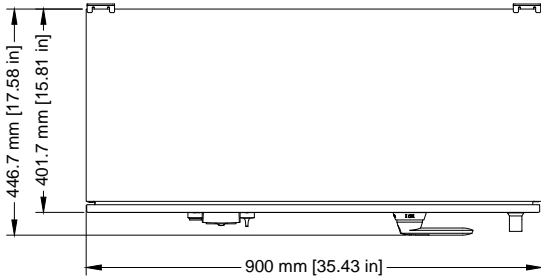

TOP VIEW
SCALE 1 / 12

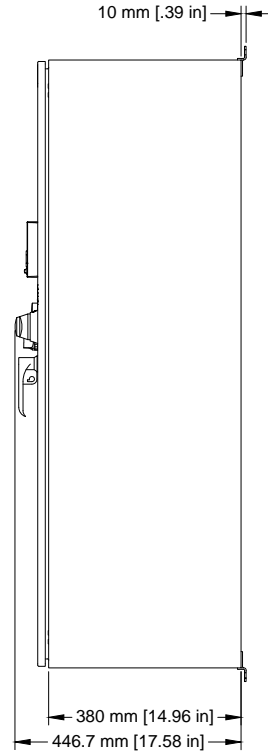

SIDE VIEW
SCALE 1 / 12

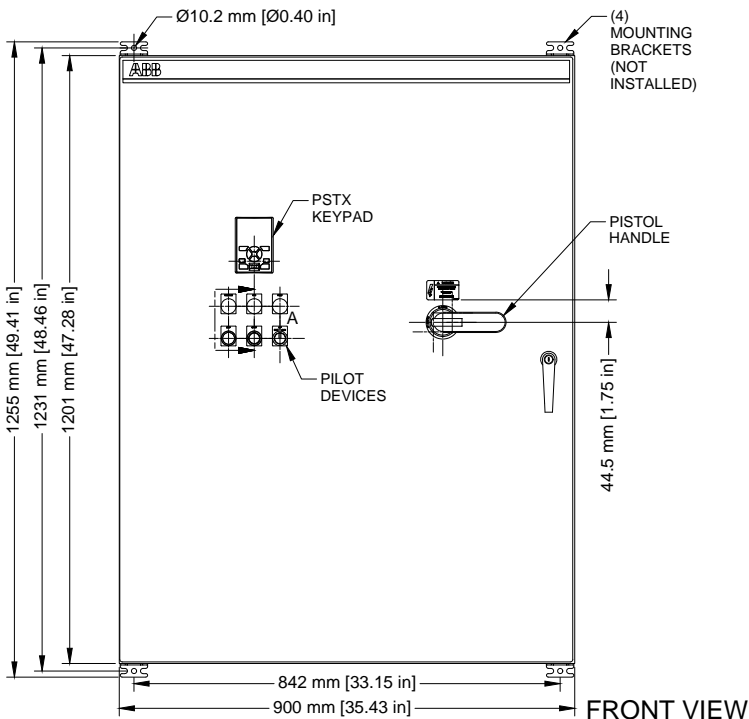

FRONT VIEW
SCALE 1 / 12

PSTX enclosed softstarters

Dimensions

X600-F4-60-ND

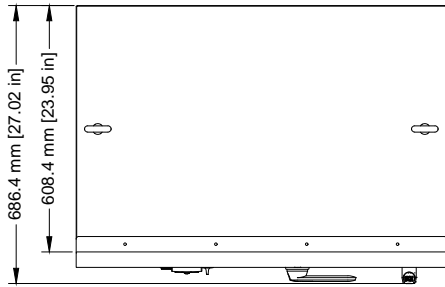

TOP VIEW
SCALE 1 / 15

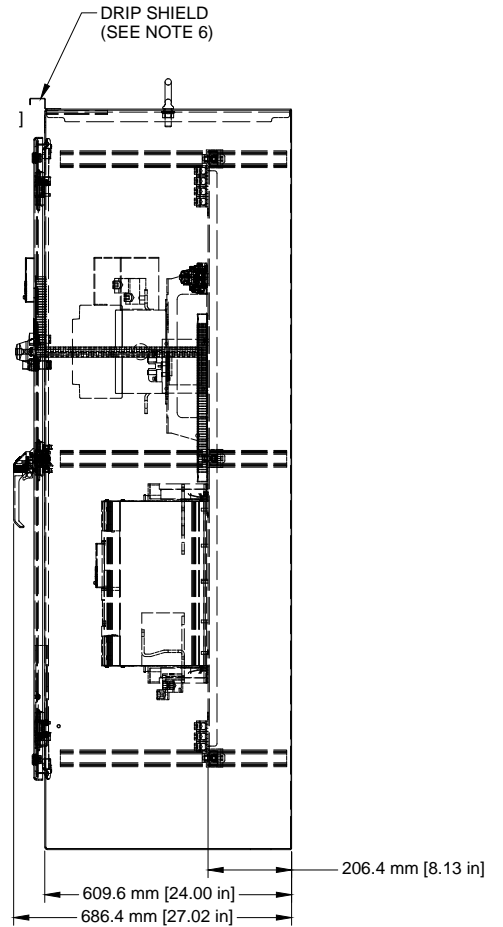

SIDE VIEW
SCALE 1 / 15

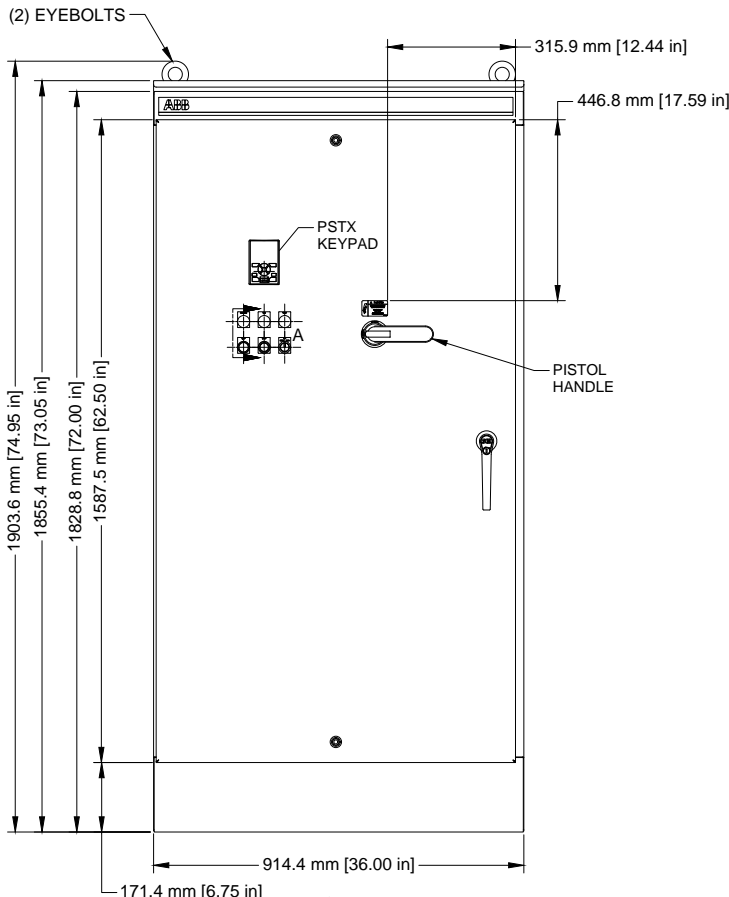

FRONT VIEW
SCALE 1 / 15

PSTX enclosed softstarters

Dimensions

X700-F4-60-ND, X800-F4-60-ND

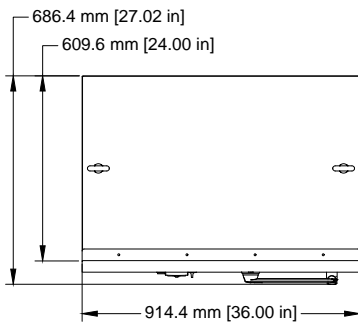

TOP VIEW
SCALE 1/20

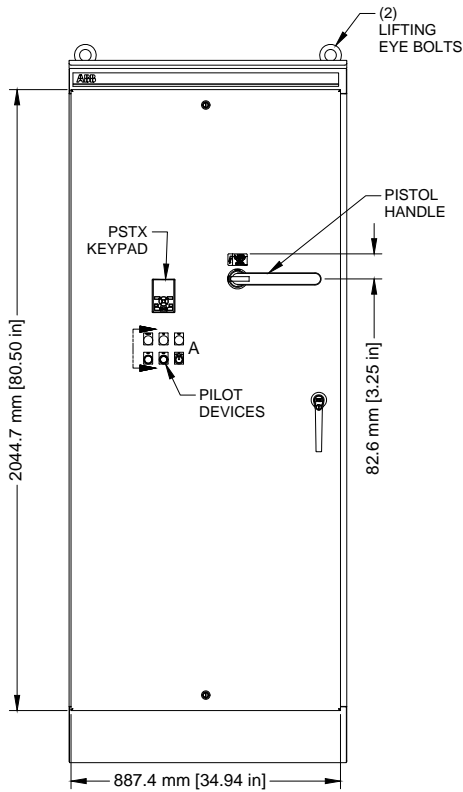

FRONT VIEW
SCALE 1/20

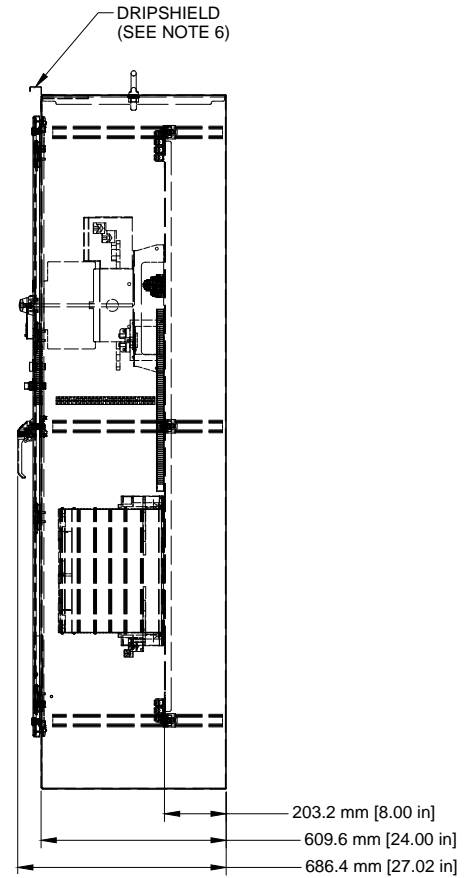

SIDE VIEW
SCALE 1/20

PSTX enclosed softstarters

Dimensions

X50-B4-48-XD

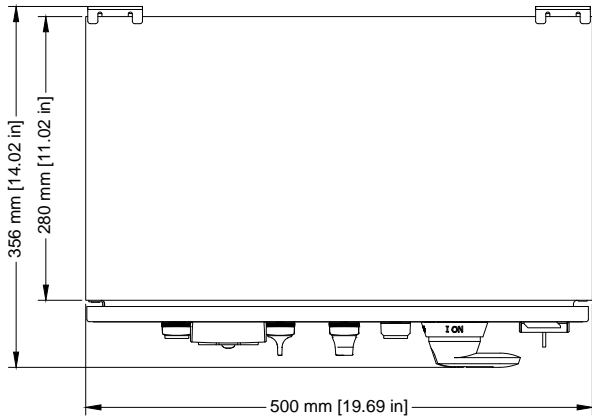

TOP VIEW
SCALE 1 / 6

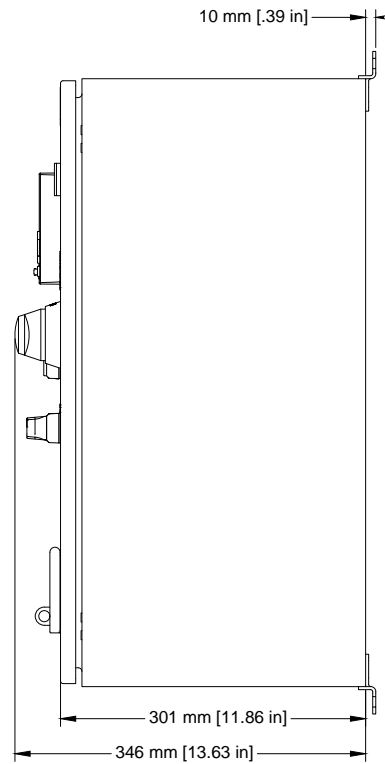

SIDE VIEW
SCALE 1 / 6

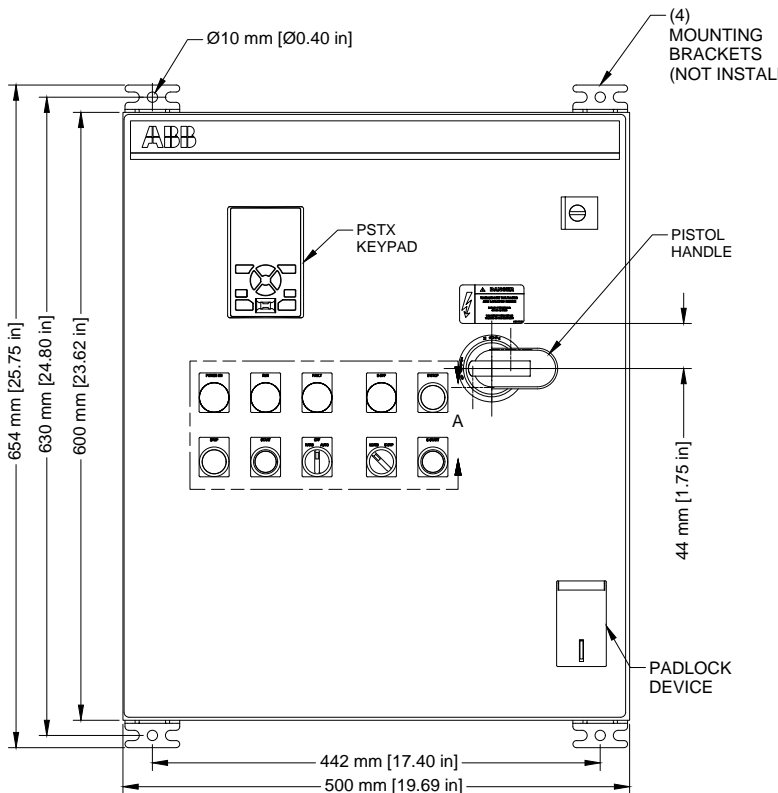

FRONT VIEW
SCALE 1 / 6

PSTX enclosed softstarters

Dimensions

X75-B4-48-XD, X100-B4-48-XD

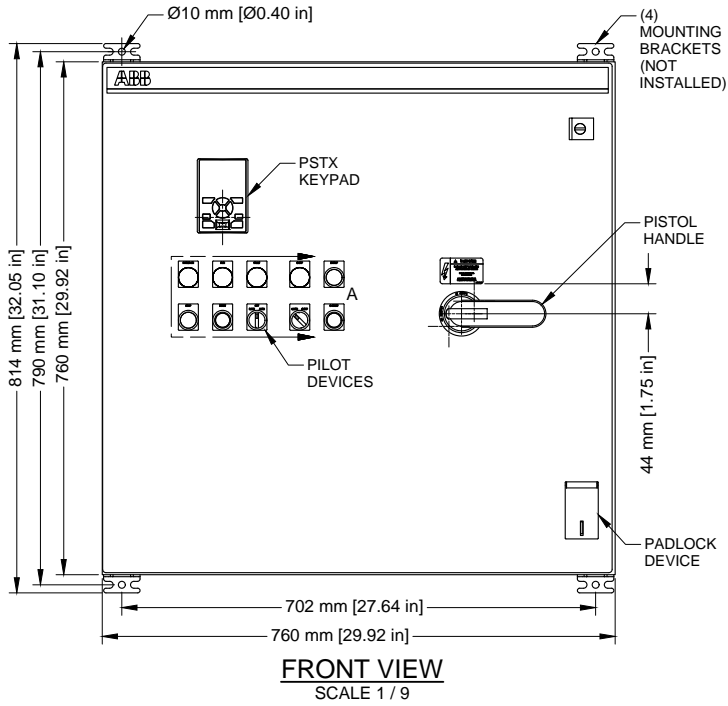
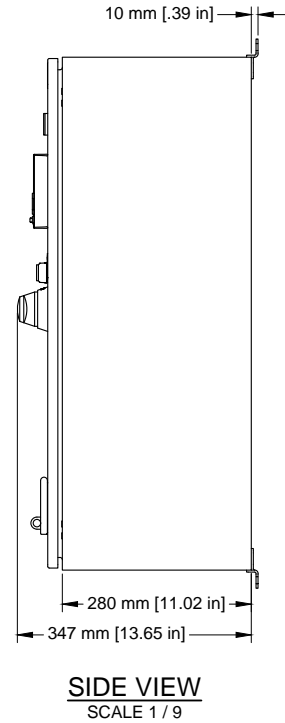
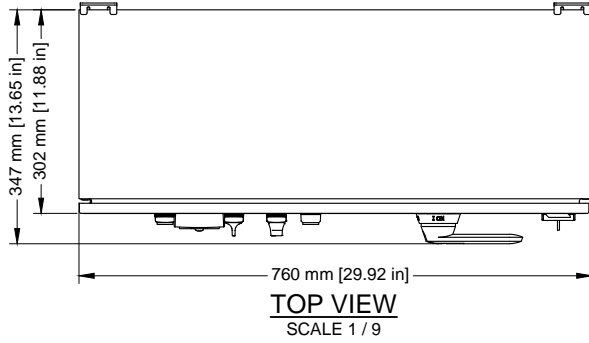

PSTX enclosed softstarters

Dimensions

X125-B4-48-XD, X150-B4-48-XD



TOP VIEW
SCALE 1 / 12

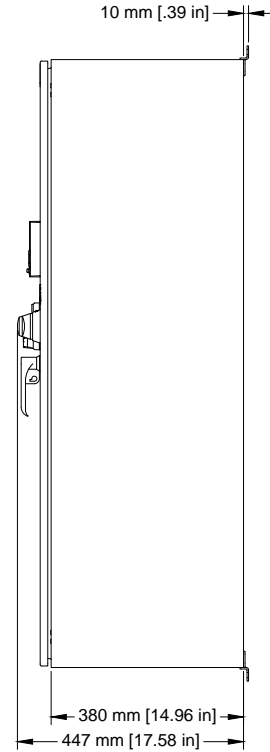

SIDE VIEW
SCALE 1 / 12

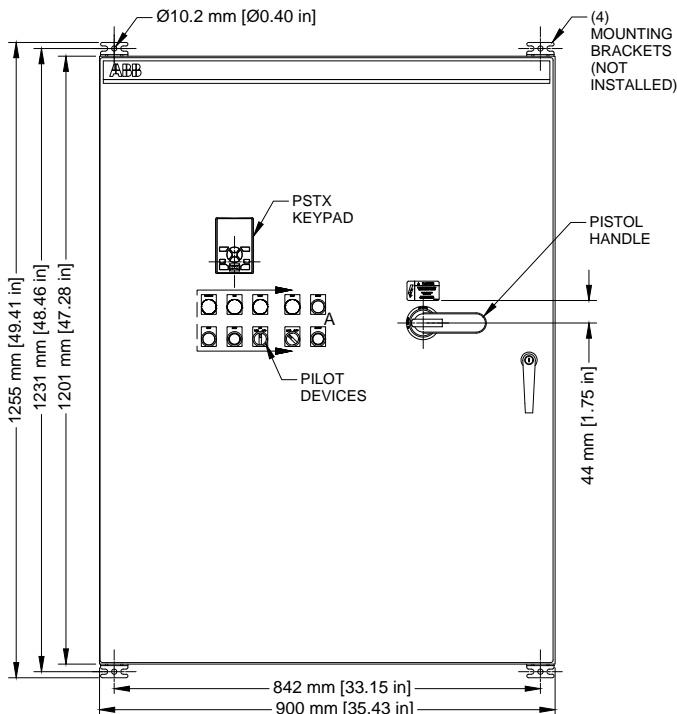

FRONT VIEW
SCALE 1 / 12

PSTX enclosed softstarters

Dimensions

X200-B4-48-XD, X250-B4-48-XD



TOP VIEW
SCALE 1 / 12

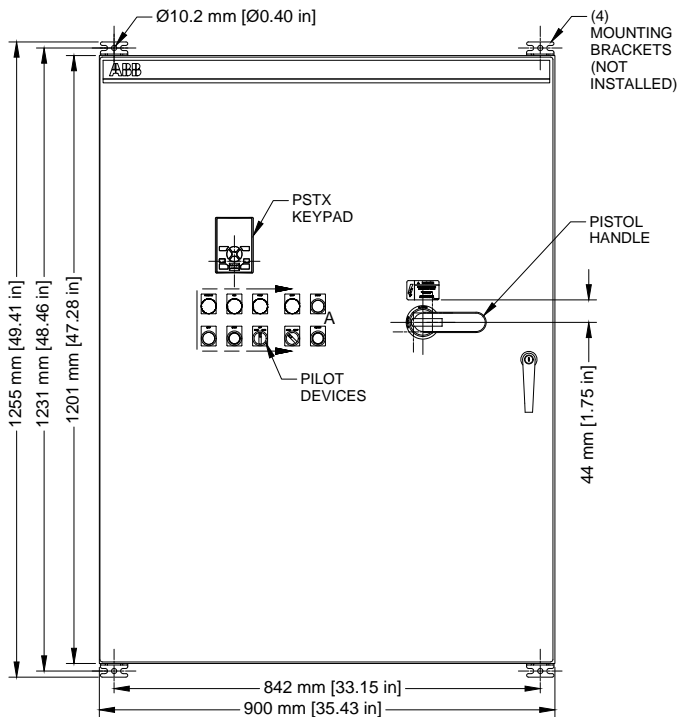

FRONT VIEW
SCALE 1 / 12

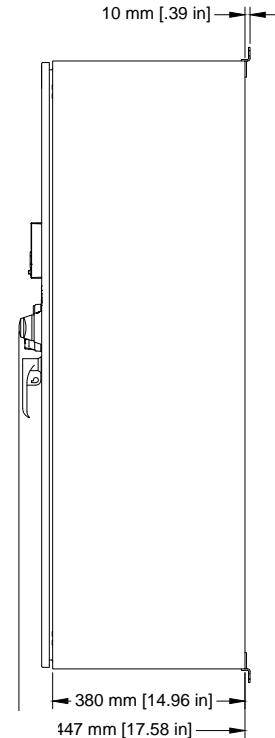

SIDE VIEW
SCALE 1 / 12

PSTX enclosed softstarters

Dimensions

X300-B4-48-XD

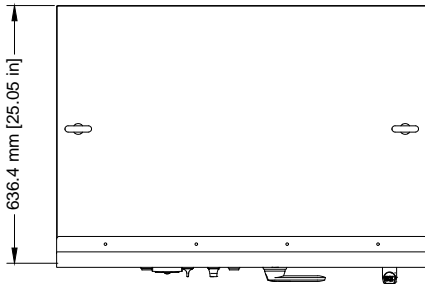

TOP VIEW
SCALE 1 / 15

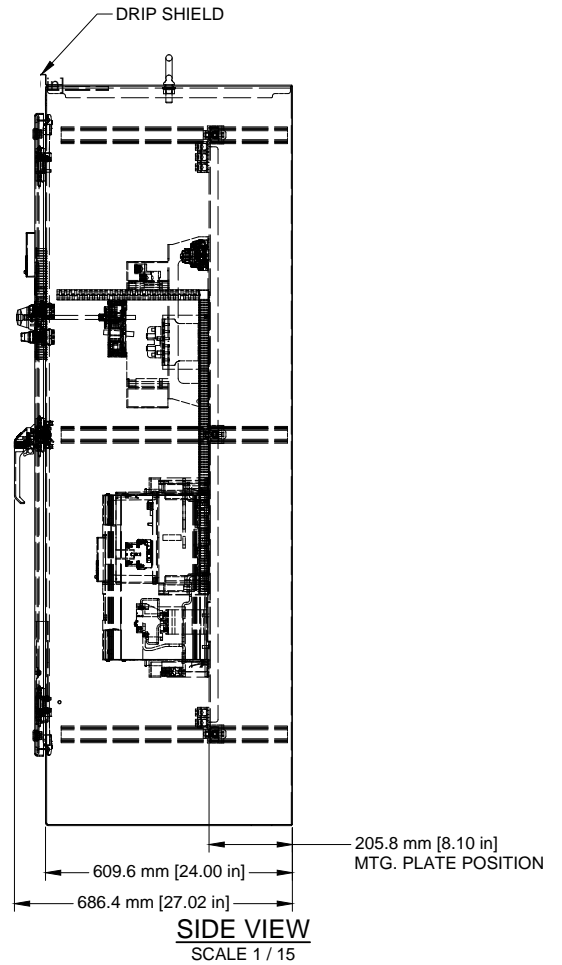

SIDE VIEW
SCALE 1 / 15

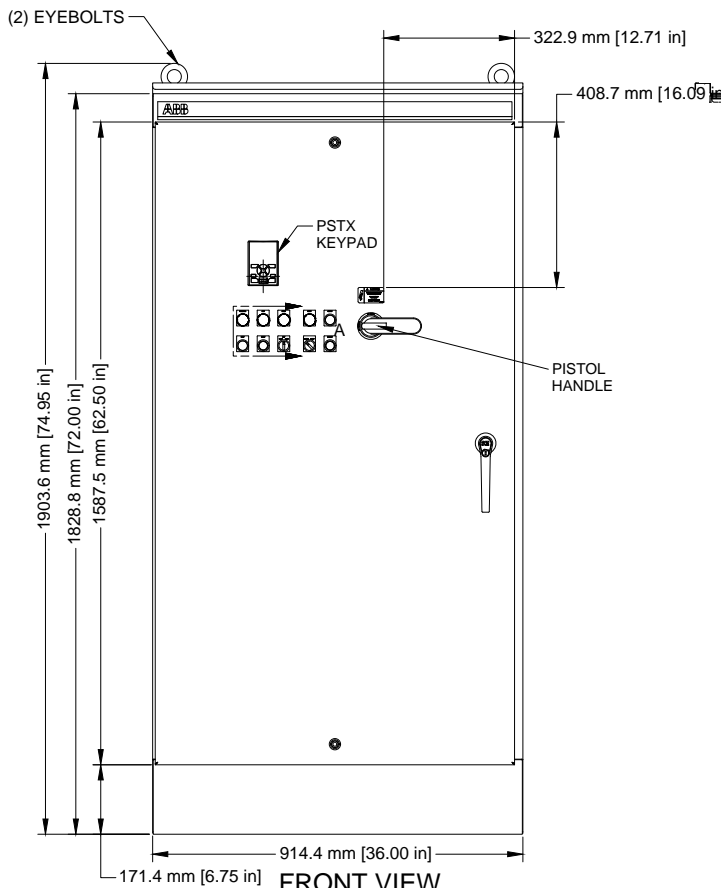

FRONT VIEW
SCALE 1 / 15

PSTX enclosed softstarters

Dimensions

X400-B4-48-XD

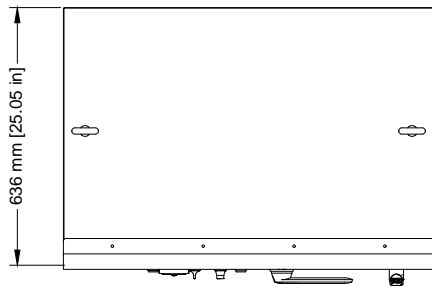

TOP VIEW
SCALE 1 / 15

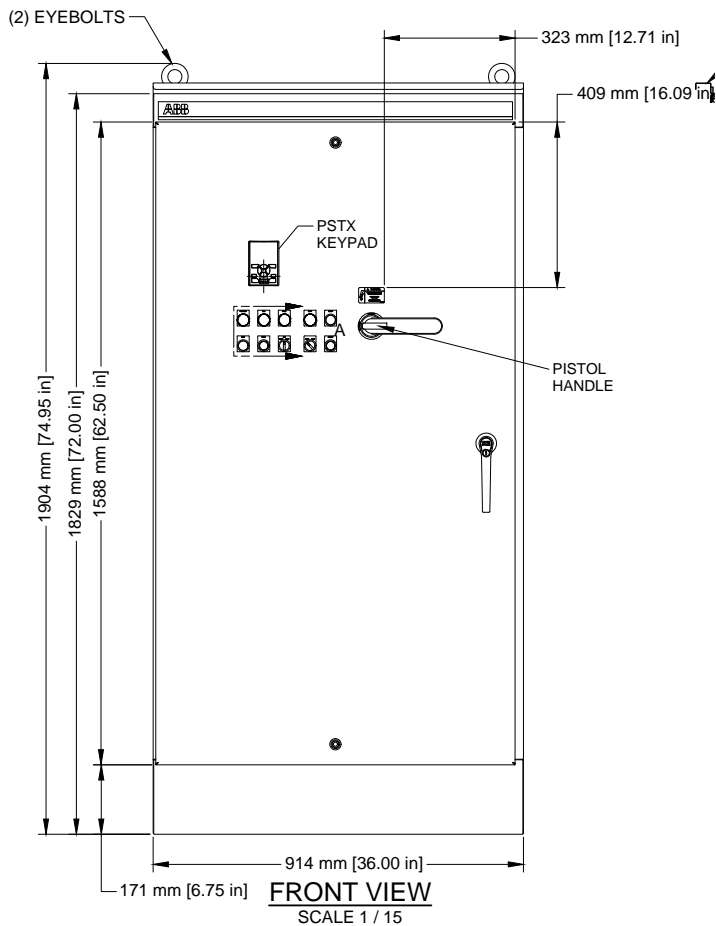

FRONT VIEW
SCALE 1 / 15

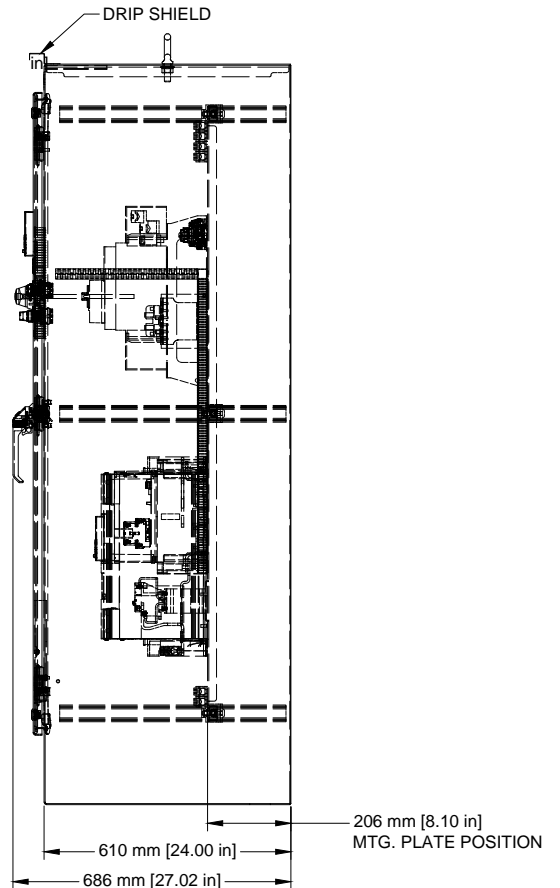

SIDE VIEW
SCALE 1 / 15

PSTX enclosed softstarters

Dimensions

X500-B4-48-XD

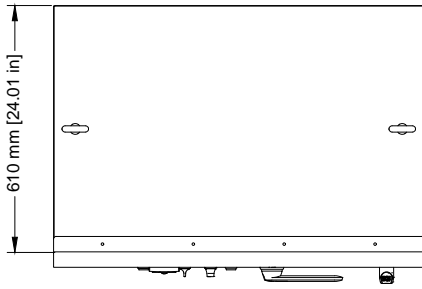

TOP VIEW
SCALE 1 / 15

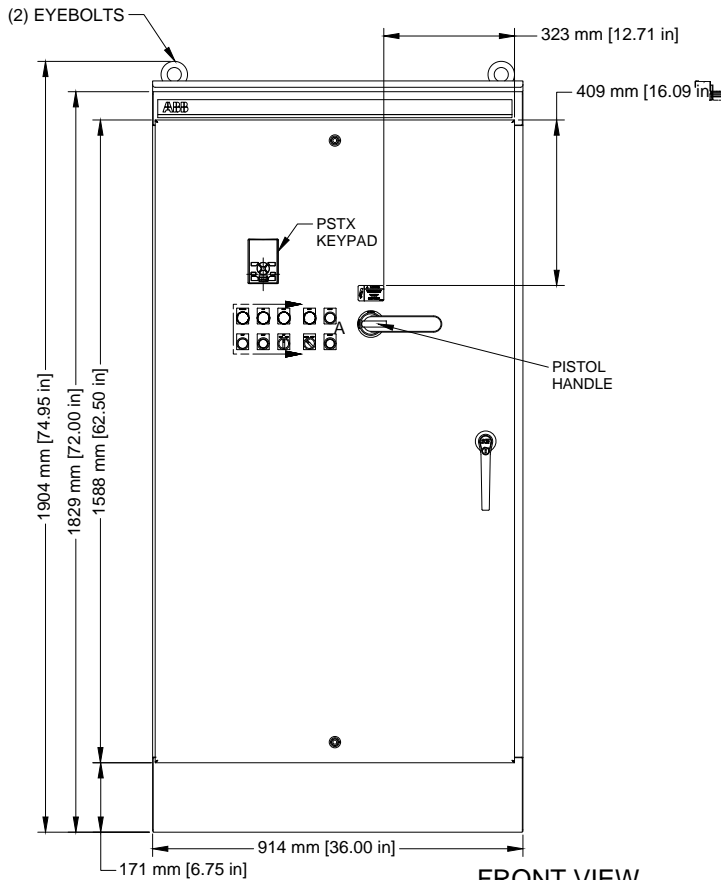

FRONT VIEW
SCALE 1 / 15

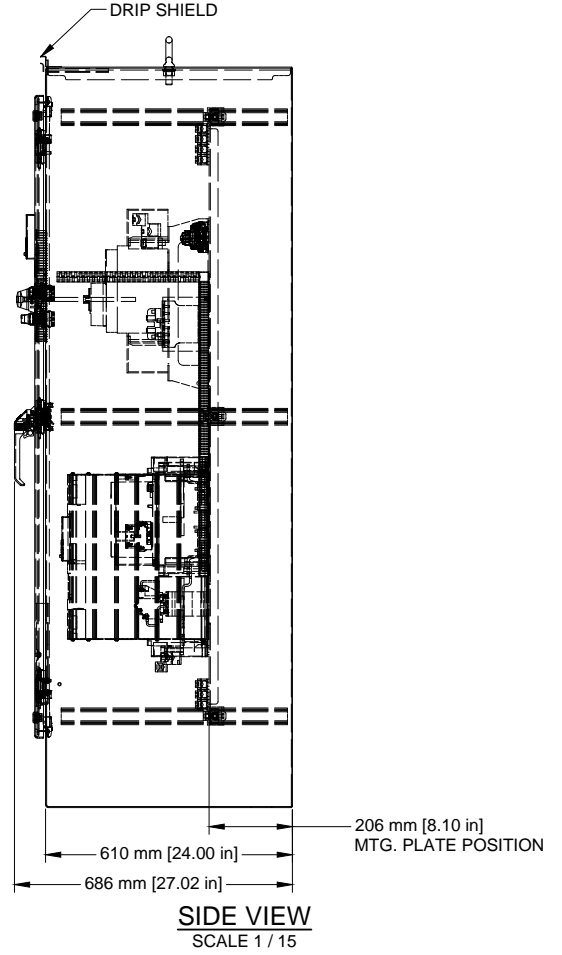

SIDE VIEW
SCALE 1 / 15

PSTX enclosed softstarters

Dimensions

X600-B4-48-XD

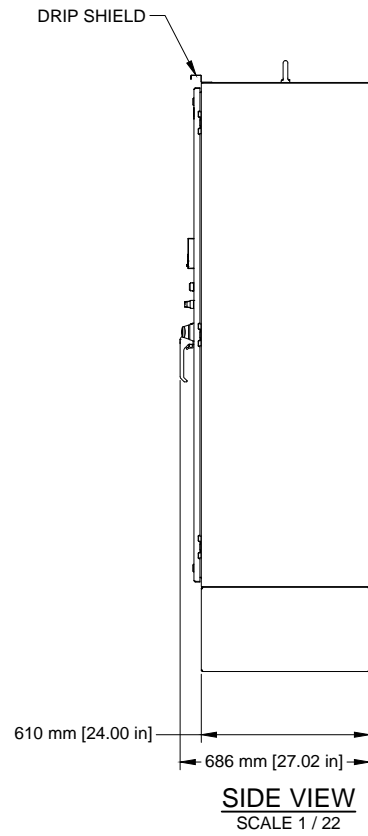
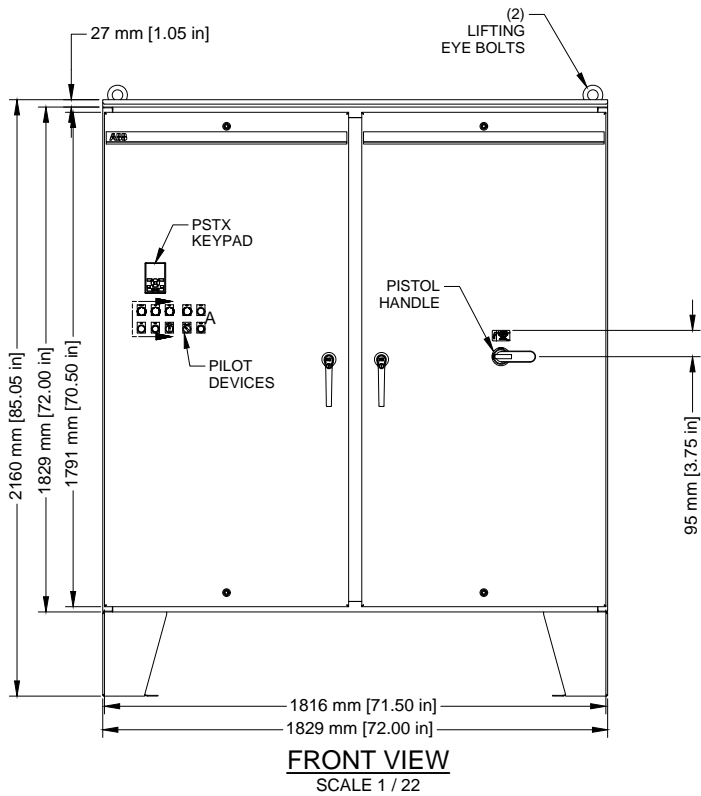
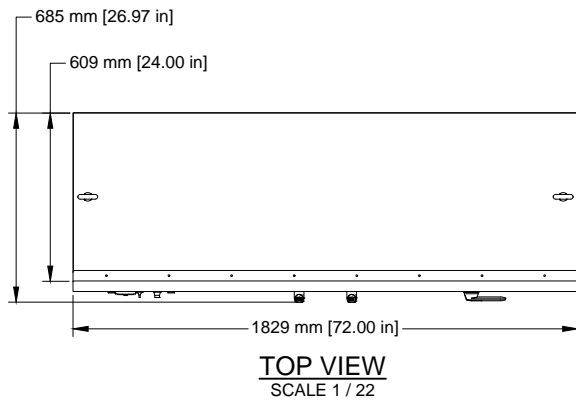

PSTX enclosed softstarters

Actual dimensions and mechanical drawings

Note: Outline drawings and wiring diagrams may be obtained by searching the file name in the [ABB Library](#).

Part number	Global product ID	Description	Enclosure	Nominal enclosure size			Depth	Outline/layout drawing	Wiring diagram
				H" x W" x D"	Height	Width			
X20-B4-48-ND	3AUA0000224500	PSTX encl 20 hp 480 V bkr ND N4 SEN-MS	Wall	24x20x12	25.75"	19.69"	14.02"	M-SST-300050	E-SST-300044
X50-B4-48-ND	3AUA0000224501	PSTX encl 50 hp 480 V bkr ND N4 SEN-MS	Wall	24x20x12	25.75"	19.69"	14.02"	M-SST-300050	E-SST-300044
X75-B4-48-ND	3AUA0000224502	PSTX encl 75 hp 480 V bkr ND N4 SEN-MS	Wall	24x20x12	25.75"	19.69"	14.02"	M-SST-300050	E-SST-300044
X100-B4-48-ND	3AUA0000224503	PSTX encl 100 hp 480 V bkr ND N4 SEN-MS	Wall	30x30x12	32.05"	29.92"	13.65"	M-SST-300062	E-SST-300044
X125-B4-48-ND	3AUA0000224504	PSTX encl 125 hp 480 V bkr ND N4 SEN-MS	Wall	30x30x12	32.05"	29.92"	13.65"	M-SST-300062	E-SST-300044
X150-B4-48-ND	3AUA0000224505	PSTX encl 150 hp 480 V bkr ND N4 SEN-MS	Wall	48x36x16	49.4"	35.4"	17.6"	M-SST-300073	E-SST-300044
X200-B4-48-ND	3AUA0000224506	PSTX encl 200 hp 480 V bkr ND N4 SEN-MS	Wall	48x36x16	49.4"	35.4"	17.6"	M-SST-300073	E-SST-300044
X250-B4-48-ND	3AUA0000224507	PSTX encl 250 hp 480 V bkr ND N4 SEN-MS	Wall	48x36x16	49.4"	35.4"	17.6"	M-SST-300074	E-SST-300044
X300-B4-48-ND	3AUA0000224508	PSTX encl 300 hp 480 V bkr ND N4 SEN-MS	Wall	48x36x16	49.4"	35.4"	17.6"	M-SST-300074	E-SST-300044
X400-B4-48-ND	3AUA0000224509	PSTX encl 400 hp 480 V bkr ND N4 SEN-MS	Wall	48x36x16	49.4"	35.4"	17.6"	M-SST-300078	E-SST-300044
X500-B4-48-ND	3AUA0000224510	PSTX encl 500 hp 480 V bkr ND N4 SEN-MS	Wall	48x36x16	49.4"	35.4"	17.6"	M-SST-300079	E-SST-300044
X600-B4-48-ND	3AUA0000224511	PSTX encl 600 hp 480 V bkr ND N4 SEN-MS	Free standing	72x36x24	74.95"	36.0"	27.02"	M-SST-300108	E-SST-300044
X700-B4-48-ND	3AUA0000224512	PSTX encl 700 hp 480 V bkr ND N4 SEN-MS	Free standing	91x36x24	93.11"	36.0"	27.03"	M-SST-300093	E-SST-300044
X25-F4-60-ND	1SQA013218R0001	PSTX encl 25 hp 600 V FD ND N4 SEN-MS	Wall	24x20x12	25.75"	19.69"	14.02"	M-SST-300052	E-SST-300046
X50-F4-60-ND	1SQA013219R0001	PSTX encl 50 hp 600 V FD ND N4 SEN-MS	Wall	24x20x12	25.75"	19.69"	14.02"	M-SST-300053	E-SST-300046
X60-F4-60-ND	1SQA013220R0001	PSTX encl 60 hp 600 V FD ND N4 SEN-MS	Wall	24x20x12	25.75"	19.69"	14.02"	M-SST-300053	E-SST-300046
X75-F4-60-ND	1SQA013221R0001	PSTX encl 75 hp 600 V FD ND N4 SEN-MS	Wall	24x20x12	25.75"	19.69"	14.02"	M-SST-300054	E-SST-300046
X100-F4-60-ND	1SQA013225R0001	PSTX encl 100 hp 600 V FD ND N4 SEN-MS	Wall	24x20x12	25.75"	19.69"	14.02"	M-SST-300054	E-SST-300046
X125-F4-60-ND	1SQA013222R0001	PSTX encl 125 hp 600 V FD ND N4 SEN-MS	Wall	30x30x12	32.05"	29.92"	13.65"	M-SST-300064	E-SST-300046
X150-F4-60-ND	1SQA013226R0001	PSTX encl 150 hp 600 V FD ND N4 SEN-MS	Wall	30x30x12	32.05"	29.92"	13.65"	M-SST-300065	E-SST-300046
X200-F4-60-ND	1SQA013227R0001	PSTX encl 200 hp 600 V FD ND N4 SEN-MS	Wall	48x36x16	49.41"	35.43"	17.58"	M-SST-300080	E-SST-300046
X250-F4-60-ND	1SQA013223R0001	PSTX encl 250 hp 600 V FD ND N4 SEN-MS	Wall	48x36x16	49.41"	35.43"	17.58"	M-SST-300080	E-SST-300046
X300-F4-60-ND	1SQA013228R0001	PSTX encl 300 hp 600 V FD ND N4 SEN-MS	Wall	48x36x16	49.41"	35.43"	17.58"	M-SST-300081	E-SST-300046
X350-F4-60-ND	1SQA013224R0001	PSTX encl 350 hp 600 V FD ND N4 SEN-MS	Wall	48x36x16	49.41"	35.43"	17.58"	M-SST-300081	E-SST-300046
X500-F4-60-ND	1SQA013229R0001	PSTX encl 500 hp 600 V FD ND N4 SEN-MS	Wall	48x36x16	49.41"	35.43"	17.58"	M-SST-300082	E-SST-300046

PSTX enclosed softstarters

Actual dimensions and mechanical drawings

Note: Outline drawings and wiring diagrams may be obtained by searching the file name in the [ABB Library](#).

Part number	Global product ID	Description	Enclosure	Nominal enclosure size			Outline/layout drawing		Wiring diagram
				H" x W" x D"	Height	Width	Depth		
X600-F4-60-ND	1SQA013230R0001	PSTX encl 600 hp 600 V FD ND N4 SEN-MS	Free standing	72x36x24	74.95"	36.0"	27.02"	M-SST-300112	E-SST-300046
X700-F4-60-ND	1SQA013231R0001	PSTX encl 700 hp 600 V FD ND N4 SEN-MS	Free standing	91x36x24	93.11"	36.0"	27.02"	M-SST-300095	E-SST-300046
X800-F4-60-ND	1SQA013232R0001	PSTX encl 800 hp 600 V FD ND N4 SEN-MS	Free standing	91x36x24	93.11"	36.0"	27.02"	M-SST-300095	E-SST-300046
X50-B4-48-XD	3AUA0000226360	PSTX encl 50 hp 480 V bkr XD N4 SEN-MS	Wall	24x20x12	25.75"	19.69"	14.02"	M-SST-300051	E-SST-300043
X75-B4-48-XD	3AUA0000226361	PSTX encl 70 hp 480 V bkr XD N4 SEN-MS	Wall	30x30x12	32.05"	29.92"	13.65"	M-SST-300063	E-SST-300043
X100-B4-48-XD	3AUA0000226362	PSTX encl 100 hp 480 V bkr XD N4 SEN-MS	Wall	30x30x12	32.05"	29.92"	13.65"	M-SST-300063	E-SST-300043
X125-B4-48-XD	3AUA0000226363	PSTX encl 125 hp 480 V bkr XD N4 SEN-MS	Wall	48x36x16	49.4"	35.4"	17.6"	M-SST-300075	E-SST-300043
X150-B4-48-XD	3AUA0000226364	PSTX encl 150 hp 480 V bkr XD N4 SEN-MS	Wall	48x36x16	49.4"	35.4"	17.6"	M-SST-300075	E-SST-300043
X200-B4-48-XD	3AUA0000226365	PSTX encl 200 hp 480 V bkr XD N4 SEN-MS	Wall	48x36x16	49.4"	35.4"	17.6"	M-SST-300076	E-SST-300043
X250-B4-48-XD	3AUA0000226366	PSTX encl 250 hp 480 V bkr XD N4 SEN-MS	Wall	48x36x16	49.4"	35.4"	17.6"	M-SST-300076	E-SST-300043
X300-B4-48-XD	3AUA0000226367	PSTX encl 300 hp 480 V bkr XD N4 SEN-MS	Free standing	72x36x24	74.95"	36.0"	27.02"	M-SST-300086	E-SST-300043
X400-B4-48-XD	3AUA0000226368	PSTX encl 400 hp 480 V bkr XD N4 SEN-MS	Free standing	72x36x24	74.95"	36.0"	27.02"	M-SST-300091	E-SST-300043
X500-B4-48-XD	3AUA0000226369	PSTX encl 500 hp 480 V bkr XD N4 SEN-MS	Free standing	72x36x24	74.95"	36.0"	27.02"	M-SST-300092	E-SST-300043
X600-B4-48-XD	3AUA0000228980	PSTX encl 600 hp 480 V bkr XD N4 SEN-MS	Free standing	85x72x24*	85.05"	72.0"	27.02"	M-SST-300104	E-SST-300043

PSTX enclosed softstarters

Representative circuit diagrams

Note: For official circuit diagrams, reference the wiring diagram file named in the actual dimensions and mechanical drawings table on the preceding pages and search in the [ABB Library](#).

X____-B4-48-ND (480 V, normal duty, breaker; electrical drawing E-SST-300044)

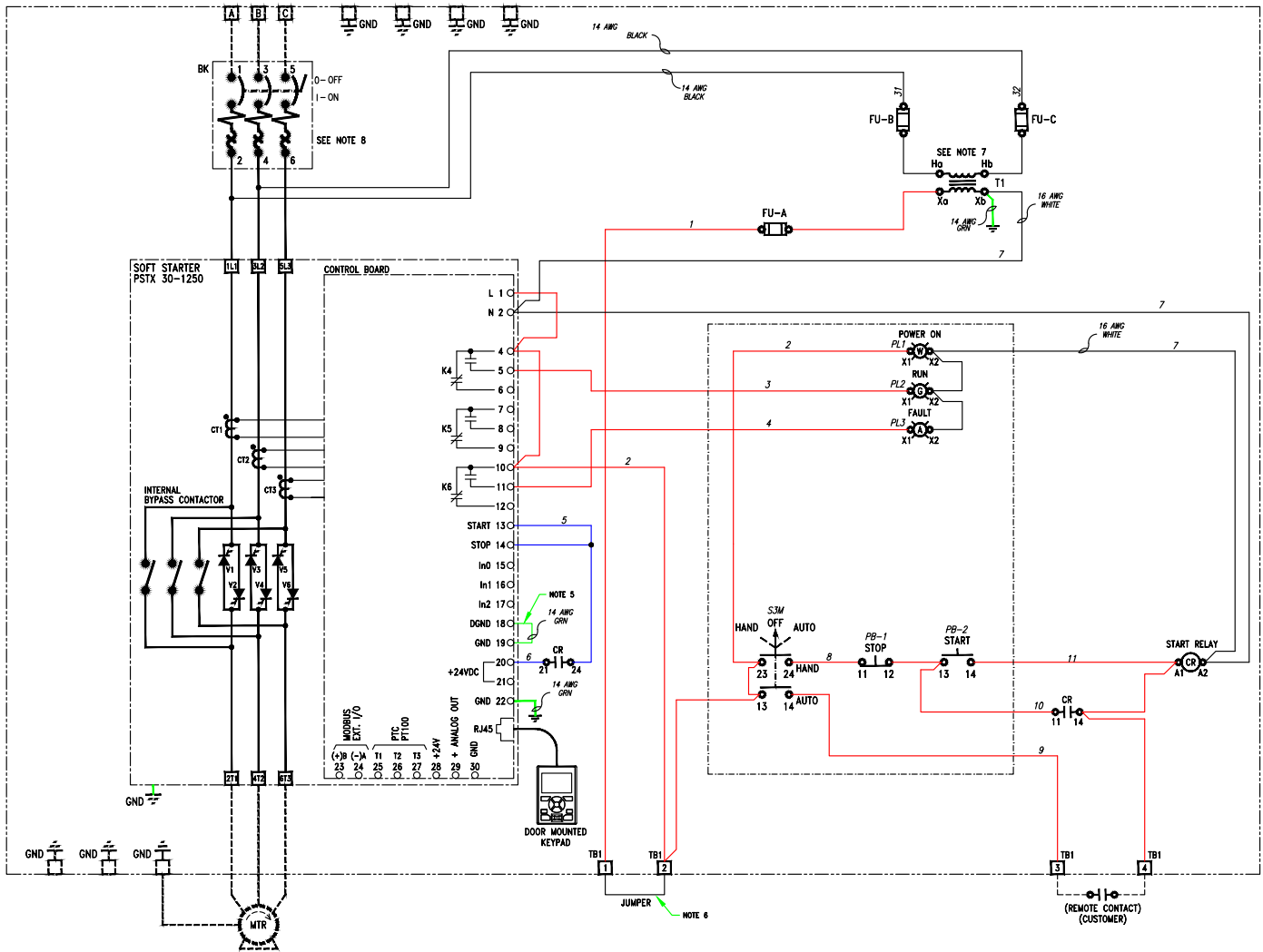

PSTX enclosed softstarters

Representative circuit diagrams

X____-B4-48-XD (480 V, extreme duty, breaker; electrical drawing E-SST-300043)

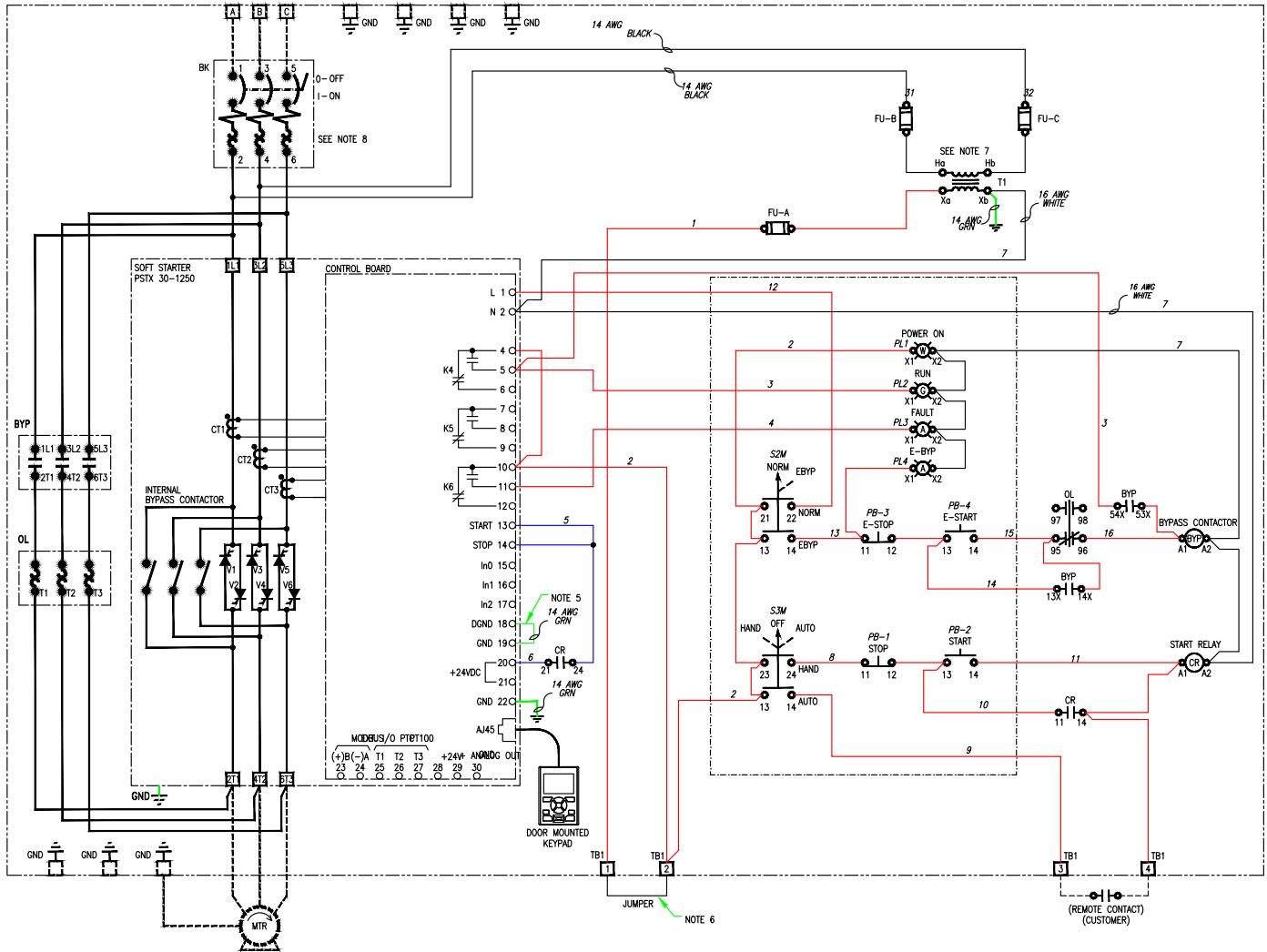

PSTX enclosed softstarters

Representative circuit diagrams

X____-F4-60-ND (600 V, normal duty, fusible; electrical drawing E-SST-300046)

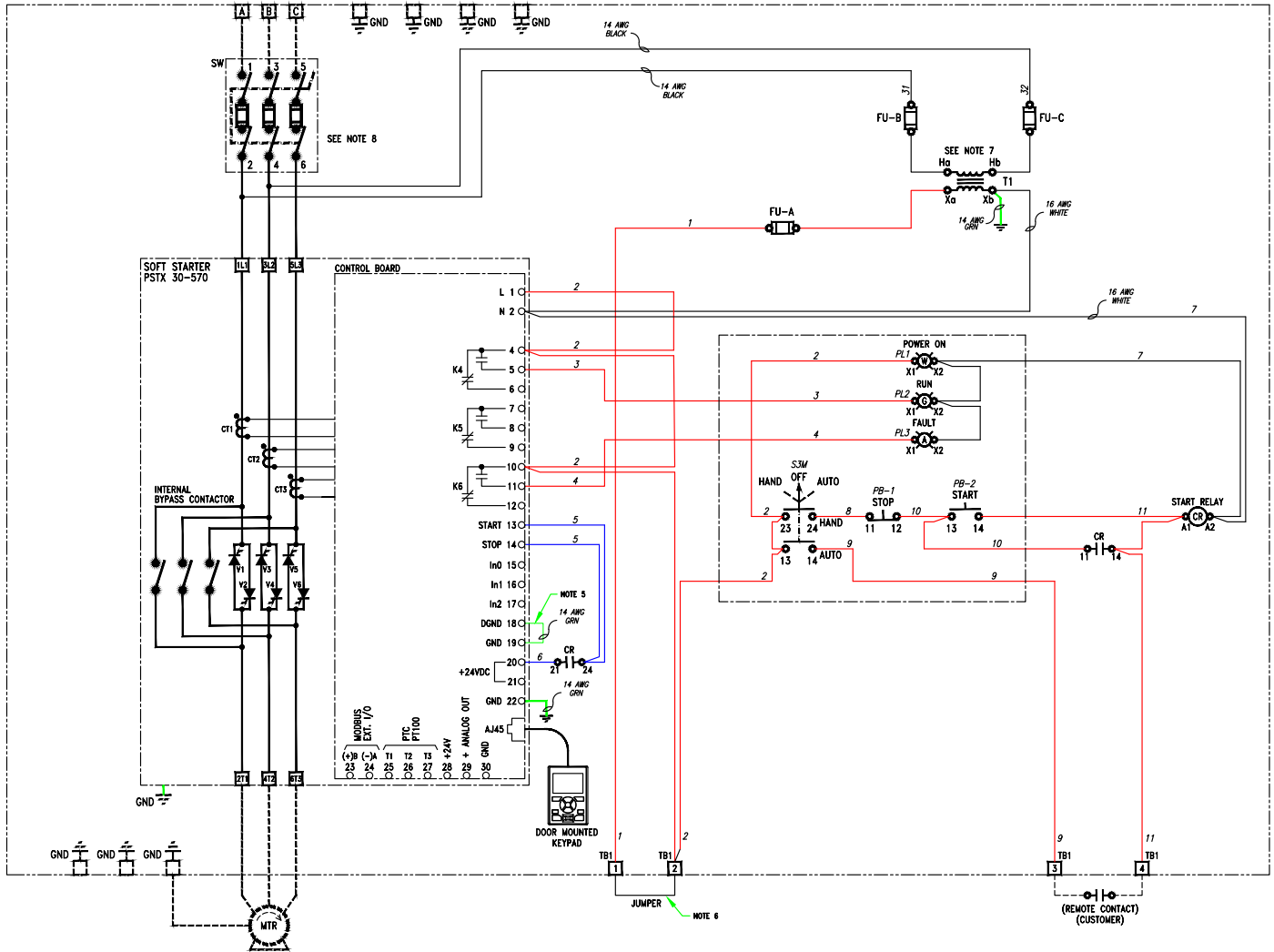

Fieldbus communication

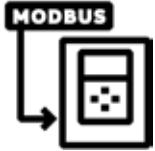

Fieldbus communication interface offering

PSTX-based softstarters can be connected to a Fieldbus network for monitoring and control. All major industrial Fieldbus protocols are covered with different accessories making the installation very flexible.

Built-in Modbus RTU

- Built-in Modbus RTU communication interface
- Easy to install using the Modbus RTU adapter, which is included with the softstarter
- Through this communication interface, it is possible to get full control and status information of the softstarter as well as reading and writing parameters

Anybus connection

- Anybus connection accessory for communication protocol suitable for X20...X1000
- Single, pluggable module to add protocol support with minimal additional installation



PROFIBUS



DeviceNet



Modbus RTU



BACnet IP



EtherNet IP



Modbus TCP



PROFINET



BACnet MS/TP



EtherCAT



CANopen

Anybus connection accessory for communication protocol suitable for PSTX30 ...PSTX1250

Article	Connection ports	Type	Order code	Pkg qty	kg	lb
Profibus	1	AB-PROFIBUS-1	1SFA899300R1001	1	0.03	0.07
DeviceNet	1	AB-DEVICENET-1	1SFA899300R1002	1	0.03	0.07
Modbus RTU ¹	1	AB-MODBUS-RTU-1	1SFA899300R1003	1	0.03	0.07
BACnet IP	2	AB- BACNET-IP-2	1SFA899300R1004	1	0.03	0.07
EtherNet/IP	2	AB-ETHERNET-IP-2	1SFA899300R1006	1	0.03	0.07
Modbus/TCP	2	AB-MODBUS-TCP-2	1SFA899300R1008	1	0.03	0.07
Profinet	2	AB-PROFINET-IO-2	1SFA899300R1010	1	0.03	0.07
BACnet MS/TP	1	AB-BACNET-MSTP-1	1SFA899300R1011	1	0.03	0.07
EtherCAT	2	AB-ETHERCAT-IP-2	1SFA899300R1012	1	0.03	0.07
New CANopen	1	AB-CANopen-IO-1	1SFA899300R1013	1	0.03	0.07

¹ Only needed when Com 3 port is used with extension I/O.

ABB Fieldbus interface

For PSTX enclosed softstarters

—
Fieldbus communication interface offering available communication protocols for softstarters

Communication	PSTX
Modbus RTU	●
Profibus	○
DeviceNet	○
Modbus TCP	—
Anybus	○

● = Built-in
 ○ = Optional
 — = not available

The diagram illustrates the fieldbus communication setup. On the left is the 'Softstarter PSTX' unit. It is connected to two communication modules: module '1' and module '2+3'. These modules are connected to an 'Ex. PLC AC500' (External PLC AC500) on the right. The connection lines show the physical interface between the softstarter and the PLC through the communication modules.

Marketing materials and tools

It is easy to access more information about ABB softstarters online. On our web page you will find tools for selection, coordination tables, CAD drawings and different types of documentation. solutions.abb/softstarters

Marketing materials

Manuals >

For help with settings, communication and more, check out the softstarter manual.

[Web page >](#)

Certificates >

ISO certificates and approvals for softstarters.

Videos >

Softstarter YouTube playlist.

Brochures >

One-page brochures for PSTX enclosed.



PSTX simulator

Software application for testing and learning more about PSTX softstarter. Simulate a motorstart in your computer an easy way to learn the menu and parameters.

[PSTX Simulator >](#)



ABB proSoft

Our popular software for the best softstarter/application match, which is free to download and use. All relevant ABB motors are preset in the tool, and all other motors can be set manually.

[ABB proSoft >](#)

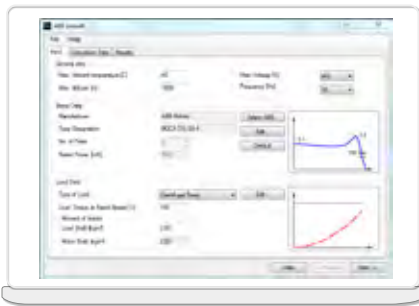

SoftstarterCare™

Service engineer tool makes softstarter commissioning easy by plugging your PSTX softstarter to a PC. Access all parameters, event logs and troubleshooting information.

[SoftstarterCare™ >](#)



**For more information, please
contact Gross Automation or
visit solutions.abb/softstarters**



For more information,
install QR code reader on
your mobile device, scan
the code and see more.

**Distributed by Gross Automation
+1(262)252-1600 or
sales@grossautomation.com**

We reserve the right to make technical changes or modify the contents of this document without prior notice. With regard to purchase orders, the agreed particulars shall prevail. ABB Inc. does not accept any responsibility whatsoever for potential errors or possible lack of information in this document.

We reserve all rights in this document and in the subject matter and illustrations contained therein. Any reproduction, disclosure to third parties or utilization of its contents – in whole or in parts – is forbidden without prior written consent of ABB Inc. Copyright© 2024 ABB
All rights reserved