

DIRIS A-100 / A-200

Power quality meter - panel mounted

Works with RJ12 or 333 mV current sensors



Function

The **DIRIS A-100 / A-200** are panel-mounted power quality meters that can communicate either via MODBUS RTU over RS485, MODBUS TCP and BACnet IP over Ethernet. The 4 independent current inputs allow to manage several types and numbers of circuits. The DIRIS A-100 / A-200 are compatible with all types of current sensor technologies: solid-core, split-core and Rogowski coil sensors to match any project requirements and installation constraints.

Advantages

Universal

The DIRIS A-100/A-200 is an all-in-one power quality meter providing a cost-effective answer to all application requirements:

- Native RS485 and dual Ethernet communication and digital inputs/outputs, eliminating the need for additional optional modules.
- Universal power supply 115 - 600 VAC.
- Wide range voltage service monitoring 90 - 690 VAC direct without using potential transformers.
- Compatible with any third party 333mV Current Transformers.

Plug & play

- Unique RJ12 technology provides a quick and reliable connection of current sensors to the power meter.
- Using mV output CTs means that no shorting blocks are needed.
- Fast and simple setup thanks to the screen's Configuration Wizard.
- Easy Config System is a free configuration software that allows you to create and save configuration templates which can later be uploaded to other A-100/A-200.
- Smart monitoring of protective devices with VirtualMonitor technology - without the need for auxiliary contacts or extra wiring.

Fully customizable

- Upload your own brand logo to customize the screen and embedded webserver.
- Creation of rolling favorite screens to display the measurement datasets that matter most to you.

Advanced features

- Waveform capture automatically triggered by power quality events to rapidly identify disturbances.
- Time of Use calendar configuration (up to 4 seasons and 4 tariffs) to align consumptions with any local utility contract.
- Ground leakage current monitoring, with alarm thresholds for preventative maintenance and quick remedial action.

Better than revenue grade

PreciSense technology provides industry leading accuracy which exceed revenue grade standards, for reliable and repeatable measurements under all conditions:

- Class 0.1 for the meter alone according to ANSI C12.20 and IEC 61557-12 standard.
- Class 0.5 from 2% to 120% of the CT rating for the global measurement chain (with TE/TR/TF/ACTL-1250 current sensors).

The solution for

- > Data center
- > Industry
- > Building

Strong points

- > Universal
- > Plug & play
- > Fully customizable
- > Advanced features
- > Better than revenue grade

Conformity to standards

- > UL 61010-1
CSA-C22.22
No. 61010-1
Guide FTRZ/PICQ
File E257746



- > ANSI C12.20



- > PBI Meter per CA Energy Commission



- > IEC 61557-12

- > IEC 62053-21 -24

Integrated technologies







For more information see our website www.socomec.us

DIRIS A-100 / A-200

Power quality meter - panel mounted

Works with RJ12 or 333 mV current sensors

				
DIRIS A	A-100	A-100	A-200	A-200
Current sensor technology	RJ12	333 mV	RJ12	333 mV
General				
Format	Door Mount	Door Mount	Door Mount	Door Mount
Number of current sensor inputs	4	4	4	4
Available enclosed			•	
Electrical				
Power supply	115 - 600 VAC	115 - 600 VAC	115 - 600 VAC	115 - 600 VAC
Voltage measurement	50 - 600 VAC L-N 90 - 690 VAC L-L	50 - 600 VAC L-N 90 - 690 VAC L-L	50 - 600 VAC L-N 90 - 690 VAC L-L	50 - 600 VAC L-N 90 - 690 VAC L-L
Communication				
RS485 Modbus RTU	•	•	•	•
Ethernet (Modbus TCP/BACnet IP)			•	•
WEBVIEW web interface			•	•
Digital Input / Output	3 / 1	3 / 1	3 / 1	3 / 1
Analog Input / Output	- / -	- / -	- / -	- / -
Energy metering				
±kWh, ±kvarh, kVAh	•	•	•	•
ΣP (kW), ΣQ (kvar), ΣS (kVA), PF	•	•	•	•
P (kW), Q (kvar), S (kVA), PF per phase	•	•	•	•
Predictive Power	•	•	•	•
Load curves / demand profiles	•	•	•	•
Peak Demand	•	•	•	•
Multi-tariff	4 (with Time of Use)	4 (with Time of Use)	4 (with Time of Use)	4 (with Time of Use)
Multi - measurement				
U12, U23, U31, V1, V2, V3, f	•	•	•	•
U system, V system	•	•	•	•
I1, I2, I3, In, I system	•	•	•	•
Unbalance U, V, I	•	•	•	•
Phi, cos Phi, tan Phi	•	•	•	•
Power quality				
THD U, V, I	•	•	•	•
Individual Harmonics U, V, I (up to 63rd)			•	•
Ground Leakage Monitoring			•	
Crest Factor I1, I2, I3	•	•	•	•
K-Factor	•	•	•	•
PQ Events (sags, swells, interruptions, overcurrents)	•	•	•	•
Waveform capture			•	•
Alarms				
Measurement thresholds	•	•	•	•
System alarms	•	•	•	•
Protective device	•	•	•	•
Logical (digital input status)	•	•	•	•
History				
Average Values	•	•	•	•
Reference	4825 0600	4825 0601	4825 0604	4825 0605

DIRIS A-100 / A-200

Power quality meter - panel mounted

Works with RJ12 or 333 mV current sensors

Functions

Monitoring

- Real-time visualization of all electrical parameters, available under several formats (bar graphs, tables)
- Phasor diagram to identify potential CT wiring errors



Consumption curves

- Recording of active (kWh), reactive (kvarh) and apparent (kVAh) energies
- Graphical view of monthly, weekly, daily or hourly energy consumptions to detect drifts



Time of Use

- Custom calendar management
- Energy consumption displayed according to the utility's daily rates, weekdays, seasons and holiday schedules



Measurement history

- History of all electrical parameters (V, I, P, Q, S, THD etc.)
- Time period selection (year, month, day etc.)
- Easy correlation, by displaying multiple parameters on the same graph

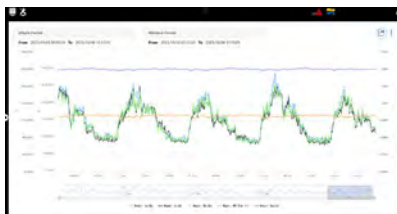

Alarms & Events

- View active alarms and power quality events
- Access to details (duration, amplitude etc.)
- Log of finished alarms & events



Waveform

- Automatic waveform captures following power quality events
- Waveform picture and samples can be downloaded from the webserver

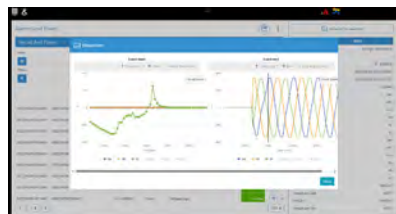

Terminals

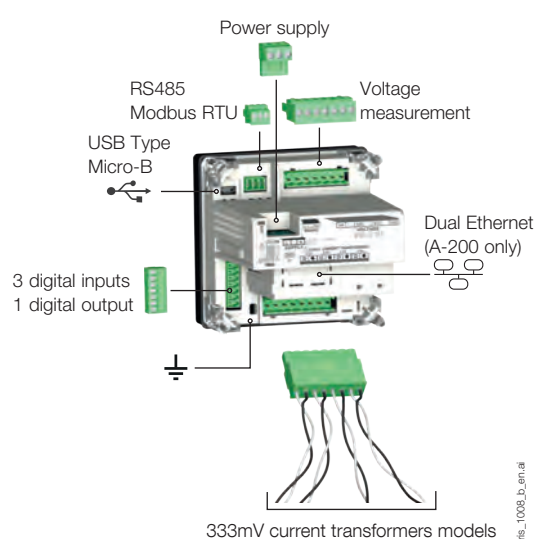
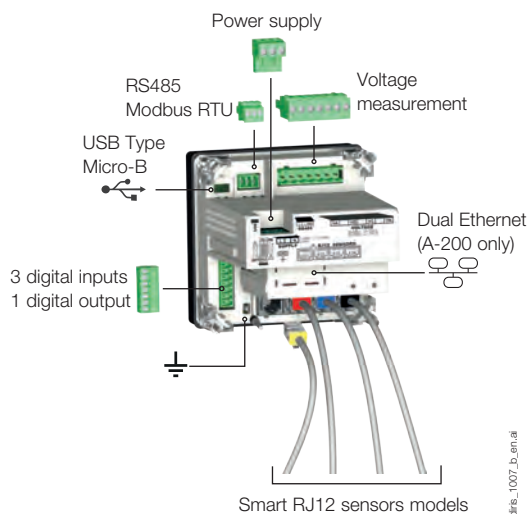

DIRIS A-100 / A-200

Power quality meter - panel mounted

Works with RJ12 or 333 mV current sensors

Terminals (continued)

3 Digital inputs
Self-supplied by PMD

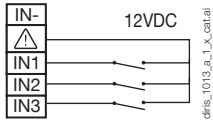

External power supply

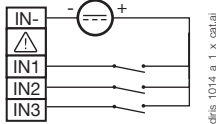

1 digital output

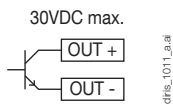

Voltage and power supply connections

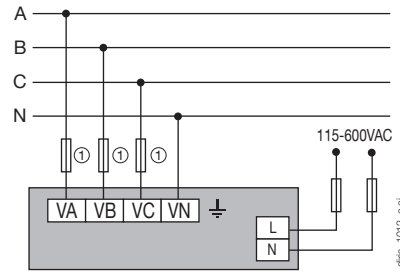

1. 1 A gG / 1 A class CC Listed fuses for UL application.

Ground



Power supply



RS485

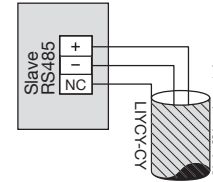

Dual Ethernet

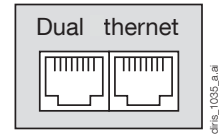

Current measurement

RJ12 version

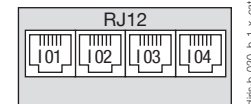

333mV version

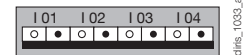

Dimensions (in/mm)

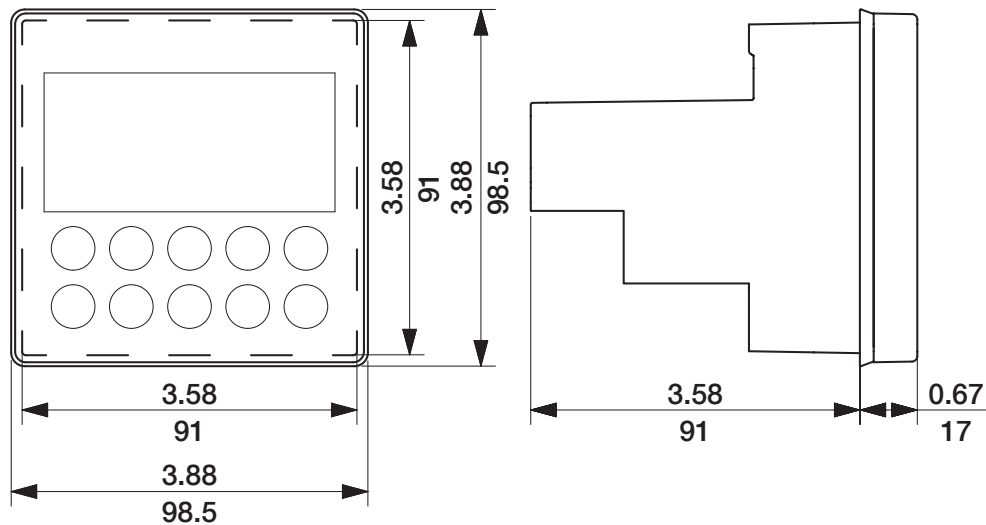

DIRIS A-100 / A-200

Power quality meter - panel mounted

Works with RJ12 or 333 mV current sensors

Current sensors

The DIRIS A-100/A-200 supports various types of current sensors including smart RJ12 solid-core (TE), split-core (TR/iTR), and Rogowski coil (TF) sensors (A-100/A-200 RJ12 models), as well as any 333 mV current sensors (A-100/A-200 333 mV models). Additionally, the DIRIS A-200 RJ12 model (reference 4825 0604) can accommodate zero-sequence $\Delta IC/\Delta IP-R$ CTs for ground leakage monitoring. This versatile range of sensors makes the DIRIS A-100/A-200 suitable for both new and existing installations.

TE solid current sensors



TR/iTR split-core current sensors



TF Rogowski current sensors



333mV current sensors



$\Delta IC/\Delta IP-R$ zero sequence CTs



RJ12 smart current sensors

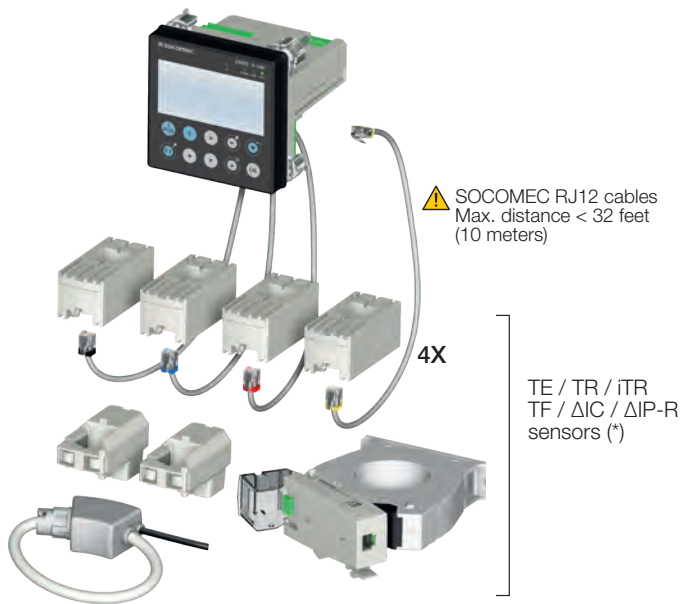

Current transformers with 333 mV outputs



(*) Notes regarding the use of zero sequence CTs:

1. ΔIC / $\Delta IP-R$ zero sequence CTs for ground leakage monitoring are only compatible with the DIRIS A-200 RJ12 model (part no 48250604).
2. Only one ΔIC / $\Delta IP-R$ may be connected on the DIRIS A-200 power meter.
3. DIRIS T-10 RJ12 adaptor (part no 48290620) must be used and ordered separately to connect ΔIC / $\Delta IP-R$ to the DIRIS A-200 power meter.

Voltage and current sensor connection examples - RJ12 models

Three-Phase, Four-Wire Wye
3P+N - 4CT
 (1 three-phase load + measured neutral)

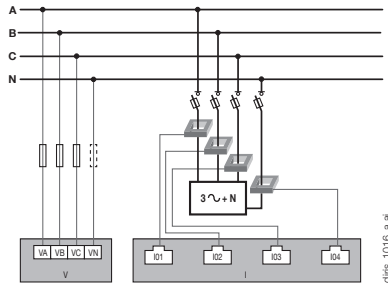

Three-Phase, Four-Wire Wye
3P+N - 3CT & 3P - 1CT
 (1 unbalanced three-phase load + calculated Neutral + 1 three-phase balanced load)

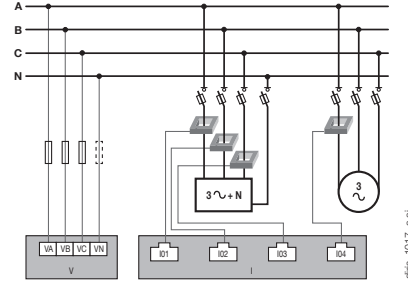

Single-Phase, Two-Wire, Line-to-Neutral
1P+N - 1CT (x4)
 (4 single-phase loads)

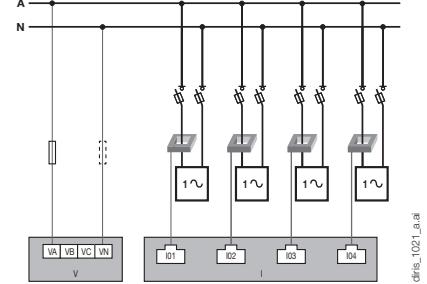

Three-Phase Four-Wire Delta (High Leg)
3P+N - 3CT
 (1 three-phase load)

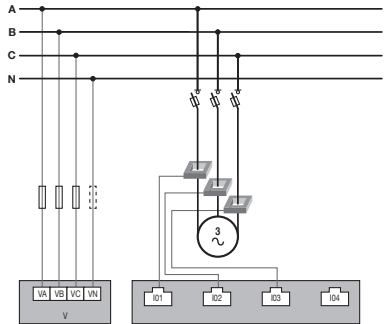

Three-Phase, Four-Wire Wye
3P+N - 3CT
 (1 three-phase load with RCM* (Δ))

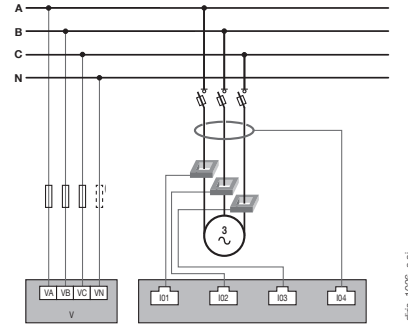

Three-Phase, Three-Wire Delta
3P - 1CT (x4)
 (4 three-phase balanced loads)

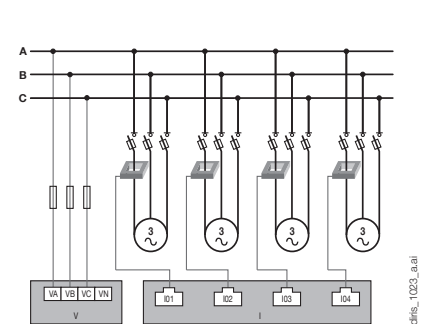

* only for DIRIS A-200 RJ12 model (ref. 48250604).

Voltage and current sensor connection examples - 333 mV models

Three-Phase, Four-Wire Wye
3P+N - 4CT
 (1 three-phase load + measured neutral)

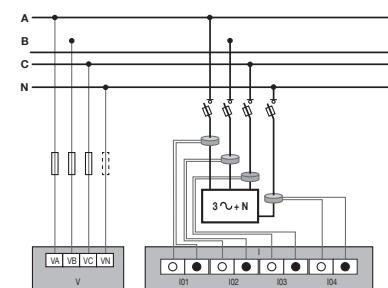

Three-Phase, Four-Wire Wye
3P+N - 3CT & 1P+N - 1CT
 (1 three-phase load + calculated Neutral + 1 single-phase load)

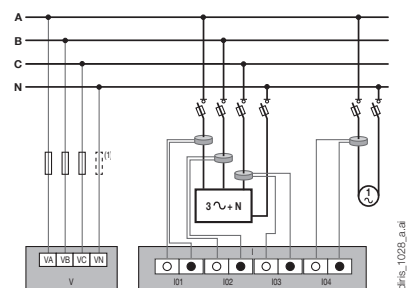

Three-Phase Four-Wire Delta (High Leg)
3P+N - 3CT
 (1 three-phase load)

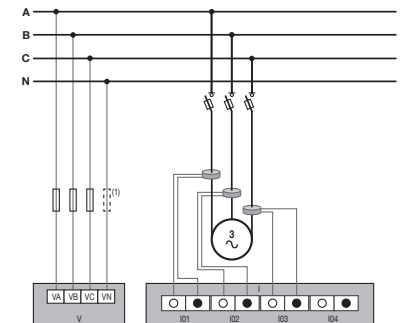



 Fuse: 1 A gG / 1 A class CC
 Listed fuses for UL application

 TE / TR / iTR / TF
 sensors

 333 mV current
 transformers

 Balanced load

 Unbalanced load

 Zero sequence CT

DIRIS A-100 / A-200

Power quality meter - panel mounted

Works with RJ12 or 333 mV current sensors

Technical characteristics

Electrical characteristics		
Power supply		
Voltage	115-600 VAC L/N L/L, CAT III	
Frequency	50-60 Hz	
Power consumption	A-100: 5VA, A-200: 7VA	
Connection (Use copper conductors only)	Removable spring-cage terminal block, 2 positions, 28-12 AWG (1-2.5 mm ²) solid or stranded cable with ferrule	
Measurement characteristics		
Standards		
Active energy accuracy	ANSI C12.20	Class 0.2 DIRIS A-100/A-200 alone
	IEC 61557-12	Class 0.2 DIRIS A-100/A-200 alone Global accuracy class from 2% to 120% of In (meter + sensors): - Class 0.5 system accuracy with TE, iTR, TF, ACTL-1250 current sensors - Class 1 system accuracy with TR or ACTL-0750 current sensors
Reactive energy accuracy	IEC 62053-24	Class 1 DIRIS A-100/A-200 alone Class 2 system accuracy with TE, TR/iTR or TF current sensors
Voltage measurement		
Voltage range	50-600 VAC L-N UL CAT III 90-690 VAC L-L UL CAT III 50-1039 VAC L-L IEC CAT III	
Frequency range	45 to 65 Hz	
Electrical service type	Single-Phase, Two-Wire, Line-to-Neutral, Single-Phase, Two-Wire, Line-to-Line, Single-Phase, Three-Wire (Split-Phase), Three-Phase, Three-Wire Delta, Three-Phase, Four-Wire Wye, Three-Phase Four-Wire Delta (High Leg)	
Measurement by voltage transformer	Primary: 400 000 VAC Secondary: 60, 100, 110, 173, 190 VAC	
Input consumption	≤ 0.1 VA	
Connection (Use copper conductors only)	Removable spring-cage terminal block, 4 positions, 28-12 AWG (1-2.5 mm ²) solid or stranded cable with ferrule	
Current measurement		
Number of current inputs	4	
Associated current sensors	- Smart RJ12 sensors: solid-core TE, split-core TR and iTR, flexible TF current sensors - 333 mV current sensors: split-core ACTL 0750-xxx, ACTL-1250-xxx - ΔIC circular solid-core and ΔIP-R circular split-core zero-sequence CT with T-10 RJ12 adaptor	

Input/output characteristics	
Inputs	
Number	3
Type / Power supply	Optocoupler with internal (12 VDC ± 10%) or external (10-30 VDC) polarisation 27 mA max.
Input function	Logical state, pulse meter, breaker status or sync. pulse signal (input 1)
Connection	Removable screw terminal block, 5 positions, stranded or solid 18-16 AWG (0.5-1.5 mm ²)
Outputs	
Number	1
Type	Optocoupler 30 VDC max 20 mA max - SELV
Output function	Configurable alarm signal (current, power, etc.) when threshold is exceeded or remote control through communication command
Connection	Removable screw terminal block, 4 positions, stranded or solid 18-16 AWG (0.5-1.5 mm ²)

Communication characteristics

RS485	
Link	RS485
Connection type	Half-Duplex, 2 wires
Protocol	Modbus RTU
Baud rate	9600 to 115200 bauds

Ethernet (A-200 only)	
Link	Ethernet
Connection type	RJ45 10/100 Mbs
Protocol	Modbus TCP/IP, BACnet IP

USB	
Link	USB Type Micro-B
Purpose	Configuration via Easy Config System and firmware upgrade via Product Upgrade Tool

Environmental characteristics

Storage temperature	-40 ... +85°C / -40 ... +185°F (ANSI C12.1)
Operating temperature	-25 ... +70°C / -13 ... +158°F (ANSI C12.1)
Humidity	5 to 95% RH non condensing (ANSI C12.1)
Degree of pollution	2

DIRIS A-100 / A-200

Power quality meter - panel mounted

Works with RJ12 or 333 mV current sensors

References

DIRIS A power meters

DIRIS A-100	RS485 - Smart RJ12 current sensors	4825 0600
DIRIS A-100	RS485 - 333 mV current sensors	4825 0601
DIRIS A-200	RS485 + Dual Ethernet - Smart RJ12 current sensors	4825 0604
DIRIS A-200	RS485 + Dual Ethernet - 333 mV current sensors	4825 0605

Accessories

	Sold in multiples of	Reference
DIN-rail mounting accessory	1	4825 0690
3-pole RM Class CC fuse holder to protect voltage inputs	4	5705 0003
2-pole RM Class CC fuse holder to protect power supply input	6	5701 0002
1A/5A secondary CT adapter with RJ12 output	1	4829 0599
6.5-ft USB Cable for configuration - Type A to Type Micro-B	1	4829 0050

RJ12 Solid-core current sensors ⁽¹⁾

Model	Nominal current range (A)	Real range covered (A)	Window size (in/mm)	Reference
TE-18	5 ... 20	0.1 ... 24	Ø 0.33 / 8.6	4829 0500
TE-18	25 ... 63	0.5 ... 75	Ø 0.33 / 8.6	4829 0501
TE-25	40 ... 160	0.8 ... 192	0.53 x 0.53 / 13.5 x 13.5	4829 0502
TE-35	63 ... 250	1.26 ... 300	0.82 x 0.82 / 21 x 21	4829 0503
TE-45	160 ... 630	3.2 ... 756	1.22 x 1.22 / 31 x 31	4829 0504
TE-55	400 ... 1000	8 ... 1200	1.61 x 1.61 / 41 x 41	4829 0505
TE-90	600 ... 2000	12 ... 2400	2.52 x 2.52 / 64 x 64	4829 0506

(1) Refer to pages 348-351 for more information on TE current sensors

RJ12 Split-core current sensors ⁽²⁾

Model	Nominal current range (A)	Real range covered (A)	Window size (in/mm)	Reference
TR-10 / iTR-10	25 ... 63	0.5 ... 75.6	Ø 0.39 / 10	4829 0555 / 4829 0655
TR-14 / iTR-14	40 ... 160	0.8 ... 192	Ø 0.55 / 14	4829 0556 / 4829 0656
TR-21 / iTR-21	63 ... 250	1.26 ... 300	Ø 0.83 / 21	4829 0557 / 4829 0657
TR-32 / iTR-32	160 ... 600	3.2 ... 720	Ø 1.26 / 32	4829 0558 / 4829 0658

(2) Refer to pages 352-353 for more information on TR/iTR current sensors

RJ12 Flexible Rogowski current sensors ^{(3) (4)}

Model	Nominal current range (A)	Real range covered (A)	Window size (in/mm)	Reference
TF-40	100 ... 400	2 ... 480	Ø 1.57 / 40	4829 0573
TF-80	150 ... 600	3 ... 720	Ø 3.15 / 80	4829 0574
TF-120	400 ... 2000	8 ... 2400	Ø 4.72 / 120	4829 0575
TF-200	600 ... 4000	12 ... 4800	Ø 7.87 / 200	4829 0576
TF-300	1600 ... 6000	32 ... 7200	Ø 11.81 / 300	4829 0577
TF-600	1600 ... 6000	32 ... 7200	Ø 23.62 / 600	4829 0578
Set of 3 RJ12 female/female connectors for RJ12 lead extension between power meter and TF sensor				4829 0670

(3) TF Rogowski sensors come with a 6-ft cable lead with RJ12 male connector

(4) Refer to pages 354-355 for more information on TF current sensors

RJ12 sensor lead cables	Cable length (ft / m)										164/50 reel + 100 connectors
	0.32/0.1	0.64/0.2	0.96/0.3	1.64/0.5	3.3/1	6.5/2	9.84/3	16.4/5	22.9/7	32.8/10	
Number of cables	Reference	Reference	Reference	Reference	Reference	Reference	Reference	Reference	Reference	Reference	Reference
1	-	-	-	-	-	-	-	4829 0602	-	4829 0603	4829 0601
3	4829 0580	4829 0581	4829 0582	4829 0595	4829 0583	4829 0584	4829 0606	4829 0607	4829 0608	4829 0609	-
4	-	-	-	4829 0596	4829 0588	4829 0589	-	-	-	-	-
6	4829 0590	4829 0591	4829 0592	4829 0597	4829 0593	4829 0594	-	-	-	-	-

DIRIS A-100 / A-200

Power quality meter - panel mounted

Works with RJ12 or 333 mV current sensors

References (continued)

333 mV split-core current sensors						
Model	Primary rating (A)	Real range covered (A)	Accuracy	Window size (in/mm)	Output lead length (ft / m)	Reference
TR-10W	63	3 ... 75.6	0.50%	Ø 0.39 / 10	22 / 7	194S 5010
TR-14W	160	8 ... 192	0.50%	Ø 0.55 / 14	22 / 7	194S 5014
TR-21W	250	12.5 ... 300	0.50%	Ø 0.83 / 21	22 / 7	194S 5021
TR-32W	600	30 ... 720	0.50%	Ø 1.26 / 32	22 / 7	194S 5032
ACTL-0750-20	20	0.2 ... 24	0.75%	0.78 x 0.78 / 20 x 20	8 / 2.4	USACTL0750020
ACTL-0750-20-C06	20	0.2 ... 24	0.50%	0.78 x 0.78 / 20 x 20	8 / 2.4	USACTL0750020C06
ACTL-0750-50	50	0.5 ... 60	0.75%	0.78 x 0.78 / 20 x 20	8 / 2.4	USACTL0750050
ACTL-0750-50-C06	50	0.5 ... 60	0.50%	0.78 x 0.78 / 20 x 20	8 / 2.4	USACTL0750050C06
ACTL-0750-100	100	1 ... 120	0.75%	0.78 x 0.78 / 20 x 20	8 / 2.4	USACTL07500100
ACTL-0750-100-C06	100	1 ... 120	0.50%	0.78 x 0.78 / 20 x 20	8 / 2.4	USACTL07500100C06
ACTL-0750-150	150	1.5 ... 180	0.75%	0.78 x 0.78 / 20 x 20	8 / 2.4	USACTL07500150
ACTL-0750-150-C06	150	1.5 ... 180	0.50%	0.78 x 0.78 / 20 x 20	8 / 2.4	USACTL07500150C06
ACTL-0750-200	200	2 ... 240	0.75%	0.78 x 0.78 / 20 x 20	8 / 2.4	USACTL07500200
ACTL-0750-200-C06	200	2 ... 240	0.50%	0.78 x 0.78 / 20 x 20	8 / 2.4	USACTL07500200C06
ACTL-0750-250	250	2.5 ... 300	0.75%	0.78 x 0.78 / 20 x 20	8 / 2.4	USACTL07500250
ACTL-0750-250-C06	250	2.5 ... 300	0.50%	0.78 x 0.78 / 20 x 20	8 / 2.4	USACTL07500250C06
ACTL-1250-250	250	2.5 ... 300	0.75%	Ø 1.77 x 1.26 / 45 x 32	8 / 2.4	USACTL1250250
ACTL-1250-250-C06	250	2.5 ... 300	0.50%	Ø 1.77 x 1.26 / 45 x 32	8 / 2.4	USACTL1250250C06
ACTL-1250-250-C02	250	2.5 ... 300	0.20%	Ø 1.77 x 1.26 / 45 x 32	8 / 2.4	USACTL1250250C02
ACTL-1250-400	400	4 ... 480	0.75%	Ø 1.77 x 1.26 / 45 x 32	8 / 2.4	USACTL1250400
ACTL-1250-400-C06	400	4 ... 480	0.50%	Ø 1.77 x 1.26 / 45 x 32	8 / 2.4	USACTL1250400C06
ACTL-1250-400-C02	400	4 ... 480	0.20%	Ø 1.77 x 1.26 / 45 x 32	8 / 2.4	USACTL1250400C02
ACTL-1250-600	600	6 ... 720	0.75%	Ø 1.77 x 1.26 / 45 x 32	8 / 2.4	USACTL1250600
ACTL-1250-600-C06	600	6 ... 720	0.50%	Ø 1.77 x 1.26 / 45 x 32	8 / 2.4	USACTL1250600C06
ACTL-1250-600-C02	600	6 ... 720	0.20%	Ø 1.77 x 1.26 / 45 x 32	8 / 2.4	USACTL1250600C02

Commissioning		Reference
1/2 day remote commissioning	Remote commissioning including installation verification, programming and communication testing	9230100027
1/2 day on-site commissioning	On-site commissioning including installation verification, programming and communication testing	9230100004

DIRIS A-100 / A-200

Power quality meter - panel mounted

Works with RJ12 or 333 mV current sensors

Expert Services

Our service engineers are an essential part of our team, and they are dedicated to ensuring your power monitoring system provides accurate and reliable measurements to your EPMS software or SCADA system.

Our services include:

- > Site audits to verify the proper wiring of your system
- > Personnel training on how to configure, operate and maintain power monitoring equipment and associated software
- > Remote and on-site commissioning to ensure that your system is up and running quickly, with peace of mind.

For further information, please contact your nearest SOCOMEC branch.

