

Control, Monitoring and Protection Products



General Purpose Relays



Alternating Relays



Intrinsically Safe Barrier Relays



Three-Phase Monitor Relays



Time Delay Relays

Industrial control products deliver high quality and exceptional value

When we say Macromatic is “Better by Design” we are referring to both the performance of our products and our exceptional customer service - before, during and after the sale.

Our attention to your requirements includes engineering assistance for your unique applications, quick turnaround on prototypes, and the best technical support in the industry.

Macromatic products are used in systems for a range of industries including water/ wastewater, pump and motor control, irrigation, oil and gas, HVACR, material handling, lifts and elevators and other systems requiring process control and protection.

NEED TECHNICAL HELP? HAVE A SPECIAL APPLICATION?

Can't decide which product is most suitable for your application? Need a custom-engineered solution? Having trouble setting up one of our products?

View our online Technical Resource Center at macromatic.com/technical-support or contact our team of technical advisors at macromatic.com/contact.

TABLE OF CONTENTS

PRODUCT	SERIES	PAGE
Alternating Relays	ARF, ARP, ATP	3
Alternating Relays	ARP	4
Current Sensing Relays	CAH, COKP, CAP, CMD	5
General Purpose Relays	GSC, GB, GR	6
Intrinsically Safe Barrier Relays	ISD, ISE, ISP	7
Liquid Level Control Relays	LCP	8
Seal Leakage and Over Temperature Relays	SFP, SFF, TCF, TCP	9
Single-Phase Voltage Monitor Relays	VMP, VAKP, VMKE	10
Three-Phase Voltage Monitor Relays	PMP, PMD, PBDU, PAP, PCP	11
Three-Phase Voltage Monitor Relays with Communication	PC	12
Percentage Timers and Reset Timers	PTA, RT	13
Time Delay Relays		
	THR-1 Series	14
	THR-3 Series	15
	TH4 Series	16
	THS-1 Series	17
	THL-1 Series	18
	THL-8 Series	18
	TR-5 Series	19
	TR-6 Series	20
	TD-7 Series	21
	TD-8 Series	22
	TE5 Series	23
	TE-881 and TE-6 Series	24
	TAD and TAA Series	25
	Sockets and Other Accessories	26

Innovative products to improve safety and efficiency, and reduce downtime.

Macromatic regularly introduces innovative solutions to help customers be more productive and efficient. Need a custom product? Our design and application experience makes it easy to find cost-effective advantages for your applications. You get quick turnaround on prototypes and on production.

VMKE VOLTAGE MONITORING RELAYS

Protect equipment required to operate within an upper and lower voltage limit



VMKE Series protects equipment from premature failure caused by voltage faults on single-phase systems.

- Provides voltage band protection
- Protects against overvoltage and undervoltage conditions
- Adjustable time delay available

SEE PAGE 10

TE5 SERIES TIME DELAY RELAYS

Space saving design and easy set up



TE5 Series Time Delay Relays is equipped with precise time-based control in compact package.

- 17.5 mm slim design
- 15 time delay functions available
- Adjustable factory or fixed time ranges

SEE PAGE 20

Alternating Relays

ARP Series:

- ◆ Plug-in enclosure uses standard 8- or 11-pin octal socket
- ◆ Duplex control of two loads
- ◆ 10 A SPDT, DPDT or DPDT Cross-Wired output



ARF Series:

- ◆ Flange enclosure for door mounting (back-mounted socket included)
- ◆ Duplex control of two loads
- ◆ 10 A SPDT or DPDT Cross-Wired output



ATP Series:

- ◆ Plug-in enclosure uses standard 8-pin octal or 12-pin square socket
- ◆ Triplex control of three loads
- ◆ Works with three switch inputs: LEAD, LAG and LAG2
- ◆ Optional top-mounted switch allows use as Duplexor until system expansion requires added third load
- ◆ 3 A SPNO output contacts



Equalizing run times increases equipment life and provides additional capacity.

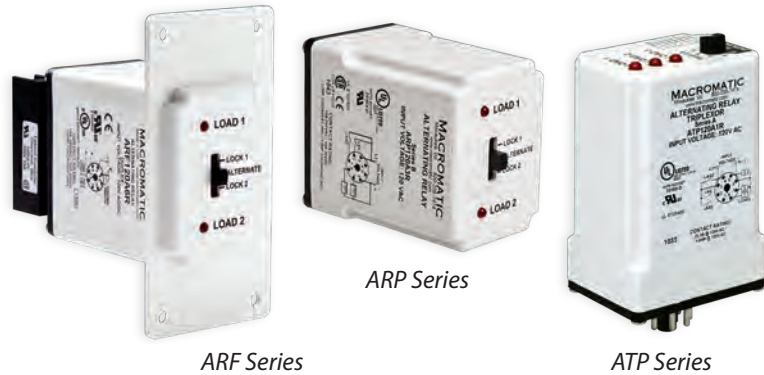

EQUALIZING THE RUN TIME OF MULTIPLE LOADS

Alternating Relays are used in applications where the optimization of load usage is required by equalizing the run time of multiple loads.

When identical loads are used for the same jobs, a standby unit is typically available in case the first load fails. However, an idle standby unit might deteriorate due to lack of use and is not a reliable backup. Alternating relays prevent this by assuring that multiple loads get equal run time.

CONTROLLING MULTIPLE LOADS FOR ADDITIONAL CAPACITY

Alternating Relays can also be used where multiple loads are on at the same time for additional capacity, if one load cannot keep up with demand.

This alternating action is normally initiated by a control switch such as a float switch or pressure switch. Each time the initiating switch is opened, turning off a load, the alternating relay will change state, thus alternating between multiple loads.

Typical applications include pump/motor units with float switches as the initiating contact, or compressors with pressure switches, or thermostats as the initiating contact.

DUPLEX AND TRIPLEX CONTROL OF LOADS

Macromatic offers two types of Alternating Relays:

Duplexor: For controlling two loads with both plug-in (ARP Series) and Flange enclosure (ARF Series) for inner-door mounting, in SPDT, DPDT and DPDT Cross-Wired output configurations. ARP Series Duplex Controllers provides Sequence On - Simultaneous OFF (S.O.S.O.) operation with three switch inputs.

Triplexor: For controlling up to three loads with plug-in enclosures (ATP Series). An optional top-mounted switch allows it to be used as a Duplexor until system expansion requires an added third load.

ARP Series Duplex Controllers:

- ◆ Combines the functions of alternating relay, control relay and auxiliary contacts in one unit.
- ◆ Protects against failures of both OFF and LEAD switches
- ◆ Space saving, compact plug-in design uses standard 8-pin octal socket
- ◆ Low-profile selector switch for normal alteration or to lock either load to be on first
- ◆ Two LEDs indicate load to be energized first
- ◆ 5A output contacts



ARP Series Duplex Controller

DUPLEX CONTROLLERS FOR S.O.S.O. OPERATION REDUCE PANEL COSTS

Many duplex pump applications require Sequence On – Simultaneous OFF (S.O.S.O.) operation with three switch inputs and alternation of which pump is turned on first. The two loads are energized sequentially when the LEAD & LAG switches close, but remain on together until the OFF switch is opened.

Macromatic ARP Series Duplex Controllers combine the function of alternating relay, control relay and auxiliary contacts in one plug-in unit. This reduces control panel cost by saving space, reducing the number of components and minimizing assembly labor.

TYPICAL MODEL CODE

ARP, ARF and ATP Series

Family	Function	Enclosure Style	Control Voltage	Output Configurations	Standard Modifications
A Alternating	R Duplexor T Triplexor		012 12V AC/DC (ARP and ARF Series only) 024 24V AC/DC 120 120V AC 240 240V AC (ARP and ARF Series only)	A1 8-pin Octal Base (ATP Series only) A2 DPDT (ARP Series only) A3 DPDT Cross-Wired, Pins 3-6 Input Voltage (ARP & ARF Series only) A4 DPDT Cross-Wired 12-pin Square Base (ARP Series only) A5 DPDT Cross-Wired, Pins 5-6 Input Voltage (ARP Series only) A6 SPDT (ARP & ARF Series only) A7 12-pin Square Base (ATP Series only) A8 Duplex Controller for S.O.S.O. Operation (Pins 3-6 Input Voltage) with standard switch to select normal alternation or lock loads 1or 2 (Model ARP***A8R)	
P Plug-in F Flange Mounted - Available for Output Configurations A3, A6 and A8					R Optional switch to select normal alternation or lock Loads 1 or 2 (ARP Series only). Required on ARF Series model numbers. Optional switch to operate as normal Triplexor or Duplexor or lock Loads in sequence (ATP Series only). Z Bulk Packaging

SERIES	OUTPUT CONFIGURATION	SOCKETS
ARP	A2	70170-D 11-pin - Order Separately
ARP	A3, A5, A6, A8	70169-D 8-pin - Order Separately
ARP	A4	SD12-PC 12-pin - Order Separately
ATP	A1	70169-D 8-pin - Order Separately
ATP	A7	SD12-PC 12-pin - Order Separately
ARF	A3, A6	SR6P-M08G (included)

GSC Series:

- ◆ Slim relays (6 mm wide on rail) for high-density applications
- ◆ Relay and socket assembled as one unit for use together.
- ◆ One Form C contact
- ◆ High capacity 6 Amp rating

GB Series:

- ◆ "Ice Cube" style with blade terminals
- ◆ Economical, compact design
- ◆ Sockets for DIN-rail or screw mounting
- ◆ Two Form C contacts rated 12 Amp
- ◆ Three Form C contacts rated 10 Amp
- ◆ Four Form C contacts rated 6 Amp

GR Series:

- ◆ "Ice Cube" style with octal (round) terminals
- ◆ Economical, compact design
- ◆ Sockets for DIN-rail or screw mounting
- ◆ Two Form C or Three Form C contacts rated 10 Amp

Approvals for all General Purpose Relays:



Compact, side-by-side mounting simplifies installation and wiring for reduced costs.

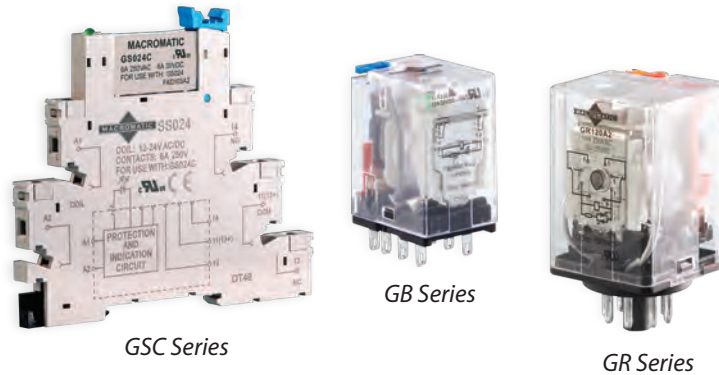

COMPACT DESIGN PROVIDES ECONOMICAL AND RELIABLE OPERATION

Small profile General Purpose Relays make the best use of panel space in applications with space restrictions. The relays are economical for reduced system cost.

Three configurations offer mounting versatility. Slim GSC Series relays, installed in sockets for DIN-rail mounting, are only 0.25 in (6 mm) wide. GB Series (blade terminals) and GR series (octal terminals) installed on sockets can be DIN-Rail or screw mounted.

EASY INSTALLATION, TESTING AND TROUBLESHOOTING

Side-by-side DIN-rail mounting simplifies installation and wiring. GB Series and GR Series are color coded for easy testing and troubleshooting of control logic circuits. AC voltage units have orange "Push-to-Test" buttons. DC voltage units have blue "Push to Test" buttons.

The buttons can be pushed for a momentary test. Or, they can be locked in place with a simple 90-degree rotation. All relays have an LED light for visual confirmation that the relay is energized. AC is red and DC is green.

TYPICAL MODEL CODE

GSC, GB and GR Series

Family	Style	Control Voltage	Output Contacts	Options
G General Purpose	SC Slim DIN Rail B Blade Terminal R Octal Terminal	024 24V AC/DC (GS Series) ■ 120 120V AC/DC (GS Series) ■ 024A 24V AC (GB Series) 024D 24V DC (GB and GR Series) 120A 120V AC (GB and GR Series) 240A 240 V AC (GB Series)	2 2 Form C (GB and GR Series Only) 3 3 Form C (GB and GR Series Only) 4 4 Form C (GB Series Only) C 1 Form C (GSC Series Only) ■	T Omit Push-to-Test (GR Series Only)

- GSC024C is comprised of GS024C (relay) and SS024 (socket). GSC120C is comprised of GS060C (relay) and SS120 (socket).

ACCESSORIES - ORDER SEPARATELY	
Series	Description
GSC	41F-J1B Jumper
	41F-S Separator
GB	GB-PR Retainer (Plastic)
GR	GR-MR Retainer (Metal)

SOCKETS - ORDER SEPARATELY				
Series	Contacts	C1 Suffix	C3 Suffix	C5 Suffix (Tower Style)
GB	2 Form C	18F-2Z-C1 8-blade	--	18F-2Z-C5 8-blade
	3 Form C	18F-3Z-C1 11-blade	--	SB3ZC5 11-blade
	4 Form C	18F-4Z-C1 14-blade	--	18F-4Z-C5 14-blade
GR	2 Form C	10F-2Z-C1 8-pin	SR2ZC3 8-pin	--
	3 Form C	10F-3Z-C1 11-pin	SR3ZC3 11-pin	--

Intrinsically Safe Barrier Relays

ISD and ISE Series:

- Both series are approved for use in these Hazardous Locations:
Class 1, Div 1 (Zones 0 and 1 Canada), Group A, B, C, D;
Class II, Div 1 (Zones 20 and 21 Canada), Group E, F, G;
Class III, Div 1
- Isolated 5A relay outputs
- UL913 6th Edition**



ISD Features

- Four-channel with independent selection of configuration for each.
- 60 mm wide enclosure for DIN-rail or panel mounting.
- Choice of operating modes and time delay

ISE Features

- One-channel
- 17.5 mm wide enclosure for DIN-rail or panel mounting.
- Standard or inverse logic

ISP Series:

- One-channel
- Plug-in enclosure with socket for DIN-rail or panel mounting
- Approved for use in these Hazardous Locations:
Class 1, Div 1, Group A, B, C, D
Class II, Div 1, Group E, F, G
Class III, Div 1
- Isolated 10A relay output
- UL913 6th Edition**



Protect hazardous location circuits and control loads without additional relays or contactors.



ISD Series



ISE Series



ISP Series on Socket

CIRCUIT PROTECTION AND CONTROL IN ONE COMPACT DEVICE

Intrinsically Safe Barrier Relays provide low-cost protection when controlling loads with input devices located in hazardous areas. IS circuits operate at low-energy levels that cannot ignite potentially explosive atmospheres. In the event of a fault condition, the IS barrier prevents excess voltage and current from reaching the hazardous area.

ISD SERIES: FOUR CHANNEL DIN-RAIL MOUNTED BARRIER RELAYS

ISD Series barrier relays, with a 60 mm wide enclosure, mount on 35mm DIN-rail or can be panel-mounted with screws.

These barrier relays provide a safe and reliable method to control up to four loads (motor starters, relays, etc.) with up to four input devices (switches, sensors, etc.) located in a hazardous area. Models are available for time delay or logic selection to be independently applied to each channel.

Terminals are removable for easy connection.

ISE SERIES: ONE-CHANNEL DIN-RAIL MOUNTED BARRIER RELAYS

ISE Series barrier relays, with 17.5 mm wide enclosure, mount on 35mm DIN-rail or can be panel-mounted with screws. These barrier relays provide a safe method to control a single load with a single input device located in a hazardous area.

ISP SERIES: ONE-CHANNEL PLUG-IN BARRIER RELAYS

ISP Series barrier relays, with an 8-pin plug-in design with socket, can be mounted on 35mm DIN-rail or panel-mounted with two screws. These barrier relays provide a safe method to control a single load with a single input device located in a hazardous area.

TYPICAL MODEL CODE

ISD, ISE and ISP Series

Family	Enclosure Style	Control Voltage	Function	Number of Channels	Standard Modification
IS Intrinsically Safe	D 60 mm E 17.5 mm P Plug-in	U 102-132V AC and 10-125V DC (ISD and ISE Series only) 120A 120V AC (ISP Series Only)	R Time delay or logic selection applied to all channels (ISD and ISE Series only) M Time delay or logic selection independently applied to each channel (ISD Series only)	1 1 Channel (ISE Series only) 4 4 channels (ISD Series only)	V Inverted Operation (ISE Series only)

LCP Series:

- ◆ Plug-in enclosure uses standard 8-pin octal socket
- ◆ Controls level of conductive liquids in Pump Up (Fill) or Pump Down (Drain) applications
- ◆ Single probe or dual probe models
- ◆ Probe is pulsed to prevent electroplating
- ◆ Two adjustable sensitivity ranges
- ◆ LED status indication
- ◆ Factory-fixed time delay of 1-60 seconds prevents rapid cycling (single probe only)
- ◆ 10A SPDT contacts



Precisely detect and raise, lower or maintain levels of conductive liquids.



LCP Series

SINGLE OR DUAL PROBE MODELS AVAILABLE TO MEET REQUIREMENTS

Liquid Level Control Relays detect and control levels of conductive liquids in pump up (fill) or pump down (drain) applications.

The conductive properties of the liquid complete a circuit between a probe and common when the liquid comes in contact with both. The relay compares the value of the measured resistance between probes with the set-point of the adjustable potentiometer on the device.

The output of the relay is used to control pumps, solenoids or valves to lower, raise or maintain the level of the liquid in the tank.

Single probe or dual probe configurations are available. On single probe models a fixed time delay prevents rapid cycling of the output relay and its load. Ten factory-set time delays are available.

Dual probe models are available with specific pin configurations to match competitive devices.

These relays are used in processes involving liquids such as tap water, seawater, sewage, water treatment, irrigation, chemical and pharmaceutical solutions, beer, coffee, ice cream, and many conductive liquids.

TYPICAL MODEL CODE

LCP Series

Family	Control Voltage	Function / Configuration	Sensitivity Range	Fixed Time Delay (Single Channel)	Standard Modifications																								
LCP	Liquid Level Control		<table border="1"> <tr> <td>100</td> <td>4.7K - 100K Ω</td> </tr> <tr> <td>250</td> <td>1K - 250K Ω</td> </tr> </table>	100	4.7K - 100K Ω	250	1K - 250K Ω		Z Bulk Packaging																				
100	4.7K - 100K Ω																												
250	1K - 250K Ω																												
	<table border="1"> <tr> <td>8</td> <td>24V AC</td> </tr> <tr> <td>2</td> <td>120V AC</td> </tr> <tr> <td>1</td> <td>240V AC</td> </tr> </table>	8	24V AC	2	120V AC	1	240V AC	<table border="1"> <tr> <td>A</td> <td>Single Probe Pump Up</td> </tr> <tr> <td>B</td> <td>Single Probe Pump Down</td> </tr> <tr> <td>C</td> <td>Dual Probe Pump Up (w/ Pin Configuration = SSAC & NCC unit)</td> </tr> <tr> <td>D</td> <td>Dual Probe Pump Down (w/ Pin Configuration = SSAC & NCC unit)</td> </tr> <tr> <td>E</td> <td>Dual Probe Pump Up (w/ Pin Configuration = Crouzet & SymCom Unit)</td> </tr> <tr> <td>G</td> <td>Dual Probe Pump Down (w/ Pin Configuration = Crouzet & SymCom Unit)</td> </tr> <tr> <td>H</td> <td>Dual Probe Pump Up (w/ Pin Configuration = GEMS unit)</td> </tr> <tr> <td>J</td> <td>Dual Probe Pump Down (w/ Pin Configuration = GEMS unit)</td> </tr> </table>	A	Single Probe Pump Up	B	Single Probe Pump Down	C	Dual Probe Pump Up (w/ Pin Configuration = SSAC & NCC unit)	D	Dual Probe Pump Down (w/ Pin Configuration = SSAC & NCC unit)	E	Dual Probe Pump Up (w/ Pin Configuration = Crouzet & SymCom Unit)	G	Dual Probe Pump Down (w/ Pin Configuration = Crouzet & SymCom Unit)	H	Dual Probe Pump Up (w/ Pin Configuration = GEMS unit)	J	Dual Probe Pump Down (w/ Pin Configuration = GEMS unit)		<table border="1"> <tr> <td>Fx</td> <td>Factory fixed time delay in Secs: 1, 2, 3, 4, 5, 10, 15, 20, 30, or 60 Secs Applies to Single Channel Function A & B only</td> </tr> </table>	Fx	Factory fixed time delay in Secs: 1, 2, 3, 4, 5, 10, 15, 20, 30, or 60 Secs Applies to Single Channel Function A & B only	
8	24V AC																												
2	120V AC																												
1	240V AC																												
A	Single Probe Pump Up																												
B	Single Probe Pump Down																												
C	Dual Probe Pump Up (w/ Pin Configuration = SSAC & NCC unit)																												
D	Dual Probe Pump Down (w/ Pin Configuration = SSAC & NCC unit)																												
E	Dual Probe Pump Up (w/ Pin Configuration = Crouzet & SymCom Unit)																												
G	Dual Probe Pump Down (w/ Pin Configuration = Crouzet & SymCom Unit)																												
H	Dual Probe Pump Up (w/ Pin Configuration = GEMS unit)																												
J	Dual Probe Pump Down (w/ Pin Configuration = GEMS unit)																												
Fx	Factory fixed time delay in Secs: 1, 2, 3, 4, 5, 10, 15, 20, 30, or 60 Secs Applies to Single Channel Function A & B only																												
					<table border="1"> <tr> <td></td> <td>SOCKET</td> </tr> <tr> <td>LCP</td> <td>70169-D 8-pin - Order Separately</td> </tr> </table>		SOCKET	LCP	70169-D 8-pin - Order Separately																				
	SOCKET																												
LCP	70169-D 8-pin - Order Separately																												

Seal Leakage and Over Temperature Relays

SFP Series:

- ◆ Works with pumps using Resistance Sensing Leakage Detection

SFF Series:

- ◆ Works with pumps using Resistance Sensing Leakage Detection

TC Series:

- ◆ TCP and TCF works with pumps using Resistance Sensing Leakage Detection; TCF-E works with pumps using Float Type Sensors; TCF-F works with pumps using CLS or FLS Sensors; TCF-A installed in place of existing Flygt MiniCas



Protect submersible pumps by monitoring for over temperature and shaft seal leakage.



SELECT FROM SINGLE OR DUAL CHANNEL MODELS.

Seal Leakage Relays monitor the shaft seals of submersible pumps for leakage. Select from models with Plug-in enclosures (SFP Series) or Flange Mounting (SFF Series) for mounting on inner door. Select from two sensitivity ranges to meet requirements.

Over Temperature & Seal Leakage Relays protect submersible pump motors against damage from both conditions. Select from Plug-in enclosures (TCP Series) or Flange Mounting (TCF Series) for mounting on inner door.

TYPICAL MODEL CODE

SFP and SFF Series

Family	Enclosure Style	Control Voltage	Function	Sensitivity Range	Standard Modification
SF Seal Leakage	P Plug-in F Flange Mount	024 24V AC AD7 24V AC/DC 120 120V AC 240 240V AC	A Single Channel 8-pin SPDT B Single Channel 11-pin DPDT (Plug-in only) C Dual Channel 8-pin (2) SPNO	100 4.7K - 100K Ω 250 1K - 250K Ω	Z Bulk Packaging

TYPICAL MODEL CODE

TCP and TCF Series

Family	Enclosure Style	Control Voltage	Function	Sensitivity Range	Standard Modification
TC Over Temperature	P Plug-in F Flange Mount	8 24V AC 7 24V AC/DC 2 120V AC 1 240V AC	A Combination Single Channel Seal Leak / Over Temperature 11-pin (2) SPDT - Both Automatic & Manual Reset w/ switch - Installed in place of existing Flygt MiniCAS ("F" enclosure only) D Combination Single Channel Seal Leak / Over Temperature 11-pin (2) SPDT - Both automatic & manual reset w/ switch ("F" enclosure only) E Combination Single Channel Seal Leak / Over Temperature 11-pin (2) SPDT - Both Automatic and Manual Reset w/ switch - For Ebara submersible pumps onyx using float-type leakage detection ("F" enclosure style only) F Combination Single Channel Seal Leak / Over Temperature 11-pin (2) SPDT - Both Automatic & Manual Reset w/ switch - For Xylem / Flygt submersible pumps only using a CLS or FLS sensor (MINI-CAS equivalent). ("F" enclosure only) G Combination Single Channel Seal Leak / Over Temperature 11-pin (2) SPDT - Automatic Reset only. ("P" enclosure only)	100 4.7K - 100K Ω 250 1K - 250K Ω	Z Bulk Packaging

Applied to Functions D and G only:	
100	4.7K - 100K Ω
250	1K - 250K Ω

SOCKETS	
SFF / TCF	Included
All TCP	Order Separately: 70170-D 11-pin
SFP	Order Separately:
A and C Function	70169-D 8-pin
B Function	70170-D 11-pin

Single-Phase Voltage Monitor Relays

VMP Series:

- ◆ Wide range of user-adjustable pick-up voltages

VAKP Series:

- ◆ Wide range of user-adjustable pick-up voltages
- ◆ Adjustable time delay



VWKP Series:

- ◆ Provides voltage band protection
- ◆ Wide range of user-adjustable over- and under-voltage settings
- ◆ Adjustable time delay



VMKE Series:

- ◆ 17.5mm Modular for 35mm DIN-Rail mounting
- ◆ Provides voltage band, undervoltage, overvoltage protection
- ◆ Adjustable time delay



Protect equipment from premature failure caused by voltage faults on single-phase systems.



VMP Series



VAKP Series



VMKE Series

RELAYS REQUIRE NO SEPARATE POWER SUPPLY

Voltage Monitor Relays monitor either AC single phase (50-60Hz) or DC voltages to protect equipment against voltage fault conditions. No separate supply (input) voltage is required on any Macromatic Voltage Monitor Relays since each unit is powered by monitored voltage.

Versions are available in either a plug-in enclosure using an 8-pin octal socket or a narrow 17.5mm DIN-Rail mounted case (VMKE Series only).

SELECT FROM OVER/UNDER OR VOLTAGE BAND RELAYS

Over/Under Voltage Relays protect equipment where either an over- or under-voltage condition is potentially damaging. Select from either fixed or adjustable time delay on drop-out. These relays (VMP Series and VAKP Series) are available with plug-in enclosures or with enclosures for DIN-rail mounting (VMKE Series).

Voltage Band Relays protect equipment that is required to operate within an upper and lower voltage limit. The relay stays energized as long as the monitored voltage remains within the adjustable OVER and UNDER voltage limits. These relays are available with either plug-in enclosures (VWKP Series) or with enclosures for DIN-rail mounting (VWKE Series).

TYPICAL MODEL CODE

VMP, VAKP, VWKP and VWKE Series

Family	Function	Drop-out Voltage Setting	Enclosure Style	Monitored Voltage	Standard Modifications
V	Voltage Monitor	Blank	P Plug-in		X 5A DPDT 240V instead of 10A SPDT (240A and 480A only)
M	Over/Under-voltage Relay w/ fixed time delay on drop-out	K Adjustable % of Pick-up Voltage Setting	E DIN-Rail		Z Bulk Packaging
A	Over/Under-voltage Relay w/ adjustable time delay on drop-out	SOCKET		012D 12V DC	
W	Voltage Band Relay	Plug-in 70169-D 8-pin - Order Separately		024D 24V DC	
				048D 48V DC	
				110D 110V DC	
				120A 120V AC	
				240A 240V AC	
				480A 480V AC	

TYPICAL MODEL CODE

DIN-Rail: VMKE

Family	Function	Drop-out Voltage Setting	Enclosure Style	Monitored Voltage	Standard Modifications
V	Voltage Monitor		E DIN-Rail		Z Bulk Packaging
M	Over/Under-voltage Relay w/ fixed time delay on drop-out	K Adjustable % of Pick-up Voltage Setting		012D 12V DC	
				024D 24V AC/DC	
				048D 48V AC	

Three-Phase Monitor Relays

PCP, PLP and PMP Series:

- ◆ Plug-in enclosure uses standard 8-pin octal socket
- ◆ Universal voltage range
- ◆ 10A SPDT contacts

PMP-X Series:

- ◆ Additional SPNO contact for signaling secondary systems.

PAP Series:

- ◆ Plug-in enclosure uses standard 8-pin octal socket
- ◆ 10A SPDT contacts

PMPU-FA Series:

- ◆ Universal voltage range

PMD Series:

- ◆ 52.5 mm wide enclosure for DIN-rail or panel-mounting
- ◆ Universal voltage range
- ◆ 10A SPDT contacts

PBDU Series:

- ◆ 17.5 mm wide enclosure for DIN-rail mounting
- ◆ Universal voltage range
- ◆ 10A SPDT contacts

Approvals for all Series:



Protect against premature equipment failure caused by voltage faults on 3-phase systems.



RETAINS INDICATION AND CONTINUES MONITORING EVEN WITH A LOST PHASE

Three-Phase Monitor Relays continuously monitor voltage faults on three-phase systems. They are compatible with most Wye or Delta systems with no connection to Neutral required. True RMS voltage measurement ensures more accurate sensing across more applications.

Select from models that offer protection against a combination of voltage faults. Refer to "Typical Model Code".

Phase Loss is a total loss of one or more of the three phases. This "single phasing" can be caused by a blown fuse, broken wire or worn contact and can result in motor burn-out.

Phase Reversal will cause a motor to rotate in the opposite direction. Phase Monitors can detect and protect against machinery damage or potential injury to personnel.

Phase Unbalance results from loads connected such that one or two lines carry more or less of the load. Phase Monitors can protect motors from resulting over heating.

Under-voltage is caused when voltage in all three lines drop simultaneously with an increase in current and over heating resulting in a reduction in motor performance.

Over-voltage is caused by voltage in all three lines increasing simultaneously causing a decrease in load current and poor power.

TYPICAL MODEL CODE

PCP, PLP, PMP, PMP-X, PAP, PMPU-FA, PMD and PBDU Series

Family	Function	Enclosure Style	Monitored Voltage	Standard Modifications
P	Three-Phase Monitor	P Plug-in (A, C, J, L and M Functions) D DIN-Rail (B and M Function only)		
A	Phase Loss, Phase Reversal and Under-voltage		120 102 - 138V AC (M Series only)	-FA8 Fixed Under-voltage, Unbalance and Time Delay settings on PMPU only w/ 8-pin SPDT output
B	Phase Loss, Phase Reversal and Voltage Unbalance		208 208V AC (A Series only)	-FA8X Fixed settings of -FA8 on PMPU and PJPJ w/ 8-pin SPDT and SPNO output
C	Phase Reversal only		240 240V AC (A Series only)	-FA12X Fixed settings of -FA8 on PMPU series w/ 12-pin DPDT output
J	Phase Loss, Phase Reversal and Under-voltage (All Trip) w/ Unbalance Indication only (No Trip)		400 400V AC (A Series only)	-X Additional SPNO contact (PMP Series)
L	Phase Loss and Phase Reversal		480 480V AC (A Series only)	-Z Bulk Packaging
M	Phase Loss, Phase Reversal, Voltage Unbalance, Under-voltage and Over-voltage		575 575V AC (A Series only) 460 - 600V AC (C, L and M series)	
U			190 - 500V AC (C, J, L and M Series only) 208 - 480V AC (B Series only)	SOCKET Plug-in 70169-D 8-pin - Order Separately

Three-Phase Monitor Relays with Communication

PC Series:

- ◆ Provides real-time status and measurement data via Modbus TCP
- ◆ Webserver provides access to status, measurements, and configuration from your web browser
- ◆ Protects against phase loss, phase reversal, phase unbalance, undervoltage and overvoltage
- ◆ Compact 60 mm wide enclosure for both DIN-rail or screw mounting with extendable clips
- ◆ Wide voltage ranges to cover more global applications
- ◆ True RMS voltage measurement with full wave monitoring increases accuracy
- ◆ Full fault indication on front face for easy troubleshooting
- ◆ Pluggable terminal blocks simplify initial wiring and replacement
- ◆ 5A SPDT output contacts



Relays with Modbus TCP communication to reduce downtime and service costs



Model PC1MDUL

REAL TIME AND HISTORICAL FAULT DATA FOR CONTINUOUS MONITORING

PC Series Three-Phase Monitor Relays protect equipment from voltage faults and communicate voltage parameters via Modbus TCP. This industry-first technology provides real-time alerts and intelligent evaluation and troubleshooting of voltage systems.

Communication improves decision making within smart network control systems. This affordable IoT solution is an advantage in automation applications requiring smart, connected systems including motors and voltage sensitive equipment.

PC Series relays monitor three-phase system voltages to protect from damage due to phase loss, phase reversal, phase unbalance, undervoltage and overvoltage. These products detect single phasing and unbalanced voltages regardless of any regenerative voltages.

A universal monitored voltage range of 190 to 600V AC covers more global applications.

Dials allow adjustment of the undervoltage trip point, trip delay, restart delay and unbalance trip point.

A 60 mm wide enclosure mounts on 35 mm DIN-rail or on a panel with two screws inserted through extended clips on the back of the enclosure.

Pluggable terminal blocks on both the input and output side allow for easy initial wiring and replacement without having to remove any wires.

TYPICAL MODEL CODE

PC Series

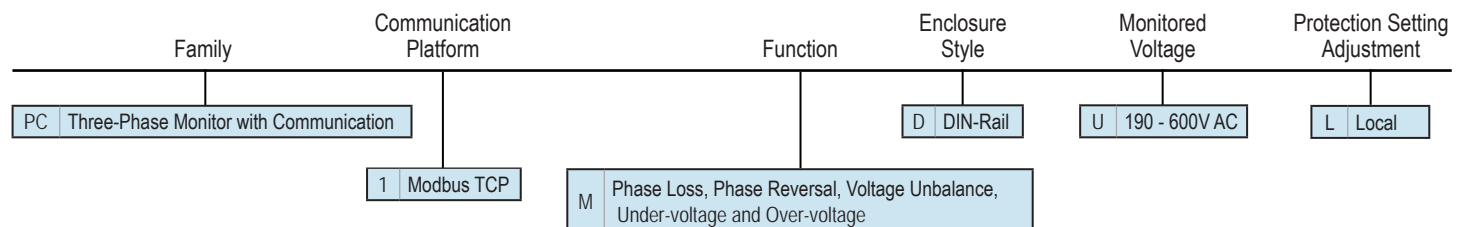

Percentage and Reset Timers

PTA Series Percentage Timers:

- ◆ Industry-standard panel cutout and mounting pattern
- ◆ Easy setting of time delay using a rotary potentiometer
- ◆ 10A SPNO output
- ◆ Available with or without memory of timing sequence



RT Series Reset Timers:

- ◆ Encapsulated enclosure for reliable operation in harsh environments
- ◆ Easy setting of time delay using a rotary potentiometer
- ◆ Available with or without memory of timing sequence



Ensure reliable and accurate timing for critical applications such as agricultural irrigation.



PTA Series



RT Series

PERCENTAGE TIMERS DELIVER RELIABLE AND ACCURATE TIMING

PTA Series microprocessor-based Percentage Timers provide reliable and accurate timing for critical applications such as agricultural irrigation. A potentiometer setting determines the ON time as a percentage of the total ON/OFF cycle time. Seven fixed total cycle times are available in seconds, minutes and hours.

SURFACE-MOUNT RESET TIMERS SAVE SPACE AND INSTALLATION TIME

RT Series microprocessor-based Reset Timers deliver reliable and accurate timing for critical applications. The compact 2" x 2" enclosure installs with a single bolt or screw through the center mounting hole, saving panel space and installation time.

TYPICAL MODEL CODE - Percentage Timers

PTA Series

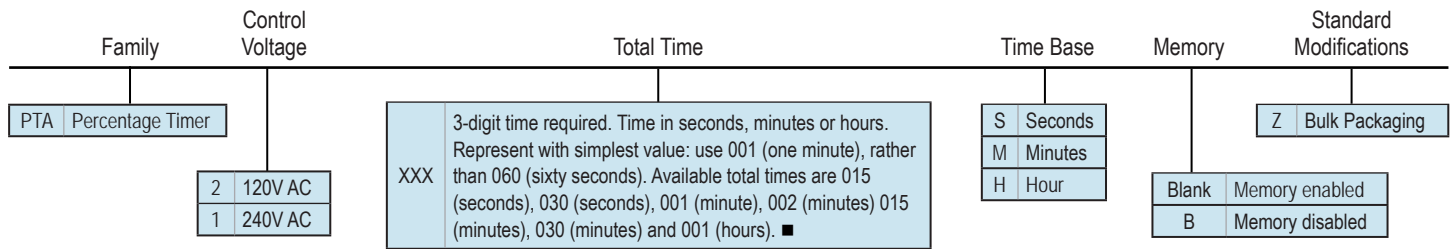

■ Example: PTA2030S = PTA with 120V, 30 second total time with memory enabled

TYPICAL MODEL CODE - Reset (Over-watering) Timers

RT Series

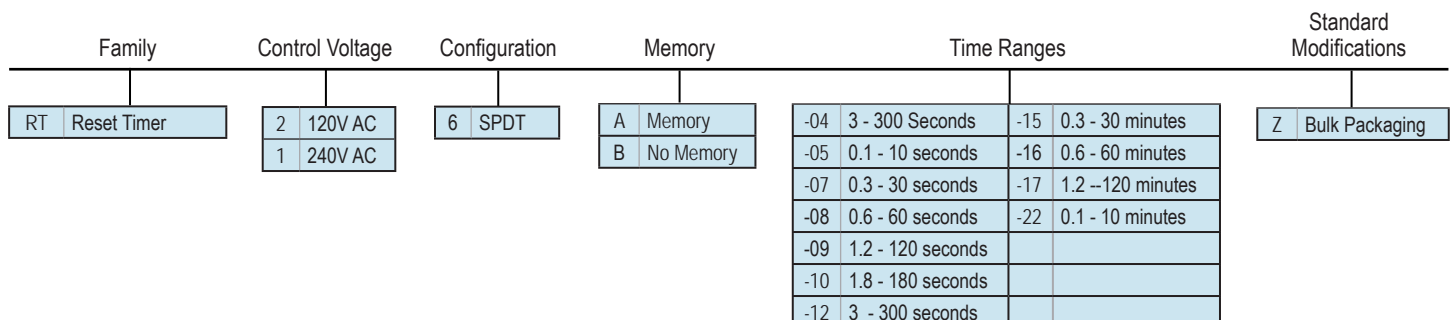

Time Delay Relays - THR-1 Series

THR-1 Series:

- ◆ Encapsulated 2" x 2" enclosure, panel mounted with one bolt or screw
- ◆ Single Function - Select from 15 Single Time or Dual Time (ON-OFF)
- ◆ Microprocessor-based design for good performance and maximum flexibility
- ◆ 10A SPDT relay output contacts can handle most pilot duty and fractional HP loads
- ◆ On-board and remote adjustable or fixed time delays from 0.05 seconds to 100 hours.



Single-function, encapsulated relays operate reliably in harsh environments.



THR-1 Series

COST-EFFECTIVE DESIGN IDEAL FOR VOLUME OEM APPLICATIONS

THR-1 Series are basic, cost-effective Time Delay Relays in a compact 2" x 2" enclosure. Encapsulation makes them resistant to the effects of harsh environments.

Setting the time delay is easy using the adjustable potentiometers. The microprocessor-based design provides good performance and maximum versatility.

These relays have three time delay options: on-board adjustable, on-board fixed, or remote adjustable settings.

TYPICAL MODEL CODE

THR-1 Series

Family	Function	Output Configuration	Control Voltage	Time Ranges	Standard Modifications
THR-1	Time Delay	5 SPNC 6 SPDT 7 SPNO	1 240V AC 2 120V AC/DC 4 48V AC/DC 6 12V DC 8 24V AC/DC	-04 0.05 - 5 seconds -30 0.1 - 10 seconds -07 0.3 - 30 seconds -08 0.6 - 60 seconds -31 1 - 100 seconds -09 1.2 - 120 seconds -10 1.8 - 180 seconds -12 3 - 300 seconds -36 10 - 1,000 seconds -32 0.1 - 10 minutes -15 0.3 - 30 minutes -16 0.6 - 60 minutes -33 1 - 100 minutes -37 10 - 1,000 minutes -17 1.2 - 120 minutes -34 0.1 - 10 hours -35 1 - 100 hours -F Fixed Time Range (i.e., F5S for Fixed 5 seconds)	REMOTE POTENTIOMETER (Only applies to Single Time Functions 02, 05, 08, 09, 12, 13, 15, 16, and 22): R1 100K (Std.) R7 1M R9 2M J Relay Common internally connected to Pin 2 T Control Switch connected to Pin 2 (applies to functions 12, 13, 15, 16, 22, 41, & 65 only) Z Bulk Packaging
	SINGLE TIME				
	02 On Delay				
	05 Interval On				
	08 Flasher (Off 1st)				
	09 Flasher (On 1st)				
	12 On Delay (Switch Trigger)				
	13 Watchdog (Switch Trigger)				
	15 Single Shot (Switch Trigger)				
	16 Off Delay (Switch Trigger)				
	22 Single Shot Falling Edge (Switch Trigger)				
	DUAL TIME (ON-OFF)				
	31 Repeat Cycle (OFF 1st)				
	41 On Delay / Off Delay (Switch Trigger)				
	51 Repeat Cycle (On 1st)				
	61 Delayed Interval				
	65 Delayed Interval (Switch Trigger)				

All combinations of R, J and T are allowed where appropriate with the function as described above except as noted by each modification.

Dual Time functions come with same ON & OFF time ranges as standard. Can be ordered in combinations of Standard or Fixed time ranges. See www.macromatic.com/onoff for details.

Time Delay Relays - THR-3 Series

THR-3 Series:

- ◆ Encapsulated 2" x 2" enclosure, panel mounted with one bolt or screw
- ◆ Multi-Function: Three models each offer 4 common time delay functions.
- ◆ Universal Voltage: 24-240V AC and 12-125VDC
- ◆ 10A SPDT relay output contacts can handle most pilot duty and fractional HP loads
- ◆ On-board & remote adjustment of time delay (remote adjustment not offered on THR-3856U)
- ◆ THR-3856U allows different ON and OFF times



Replace thousands of other devices with these programmable, multi-function relays.



THR-3 Series

ENCAPSULATION ENSURES RELIABLE OPERATION IN HARSH ENVIRONMENTS

The THR-3 Series was developed to replace thousands of products from Macromatic and many other manufacturers with just three Catalog Numbers. Each model includes four functions and four timing ranges covering 0.1 second to 100 minutes (1,000 minutes on THR-3856U dual time unit).

These relays have three time delay options: on-board adjustable, on-board fixed, or remote adjustable time delay setting (remote time delay not available on THR-3856U).

Set up is done with DIP switches for ease of use. A universal input voltage of 24-240V AC and 12-125V DC adds to the versatility of these products.

Encapsulation makes them resistant to the effects of harsh environments. A 10A SPDT relay output rating can handle most pilot duty and fractional HP loads.

TYPICAL MODEL CODE

THR-3 Series

Family	Function	Output Configuration	Control Voltage	Standard Modifications
THR-3 Time Delay	SINGLE TIME 81 Four Functions: <ul style="list-style-type: none"> ● On Delay ● Interval ● Off Delay ● Single Shot 83 Four Functions: <ul style="list-style-type: none"> ● Watchdog ● Single Shot Falling Edge ● Flasher OFF 1st ● Flasher ON 1st 85 Four Functions: <ul style="list-style-type: none"> ● Delayed Interval ● Triggered Delayed Interval ● Repeat Cycle OFF 1st ● Repeat Cycle ON 1st 	6 SPDT	U 24-240V AC and 12-125V DC	Z Bulk Packaging

Time Delay Relays - TH4 Series

TH4 Series:

- ◆ Encapsulated 2" x 3" enclosure, panel mounted with one bolt or screw
- ◆ Single Function - Select from 14 Single Time or Dual Time (ON-OFF)
- ◆ 30A SPDT relay output contacts can control heavy loads without a separate contactor
- ◆ Microprocessor-based design for superior accuracy and repeatability
- ◆ Time delays are set using adjustable on-board potentiometers, remote potentiometers, or they can be factory fixed.
- ◆ Time ranges from 0.05 seconds to 100 hours.



Effectively and economically operate heavy loads such as pumps, compressors, and heaters.



TH4 Series

30A CONTACTS CONTROL HEAVY LOADS WITHOUT A SEPARATE CONTACTOR

TH4 Series Time Delay Relays combine time-based control with high amperage switching capacity in compact 2" x 3" enclosures. This cost-effective solution can eliminate the need for a separate contactor reducing cost and saving space.

Encapsulation makes the relays resistant to harsh environments ensuring reliable operation. Electrical connections are easy using quick connect terminals.

The TH4 Series is a microprocessor-based design providing superior accuracy and repeatability.

TYPICAL MODEL CODE

TH4 Series

Family	Function	Output Configuration	Control Voltage	Time Ranges	Standard Modifications
		6 SPDT	1 240V AC/DC 2 120V AC/DC 4 48V AC/DC 6 12V DC 8 24V AC/DC	-04 0.05 - 5 seconds -30 0.1 - 10 seconds -07 0.3 - 30 seconds -08 0.6 - 60 seconds -31 1 - 100 seconds -09 1.2 - 120 seconds -10 1.8 - 180 seconds -36 10 - 1,000 seconds -32 0.1 - 10 minutes -15 0.3 - 30 minutes -16 0.6 - 60 minutes -33 1 - 100 minutes -37 10 - 1,000 minutes -17 1.2 - 120 minutes -34 0.1 - 10 hours -35 1 - 100 hours -F Fixed Time Range (i.e., F5S for Fixed 5 seconds)	R1 Remote Potentiometer - 100K J Control Voltage connected at Relay Common T Single Pin Trigger, Pin 6 (Applies to functions 12, 13, 15, 16, 22, 41, & 65 only) Z Bulk Packaging
SINGLE TIME					
02	On Delay				
05	Interval On				
08	Flasher (Off 1st)				
09	Flasher (On 1st)				
12	On Delay (Switch Trigger)				
13	Watchdog (Switch Trigger)				
15	Single Shot (Switch Trigger)				
16	Off Delay (Switch Trigger)				
22	Single Shot Falling Edge (Switch Trigger)				
DUAL TIME (ON-OFF)					
31	Repeat Cycle (OFF 1st)				
41	On Delay / Off Delay (Switch Trigger)				
51	Repeat Cycle (On 1st)				
61	Delayed Interval				
65	Delayed Interval (Switch Trigger)				

All combinations of R, J and T are allowed where appropriate with the function as described above except as noted.

Dual Time functions come with same ON & OFF time ranges as standard. Can be ordered in combinations of Standard or Fixed time ranges. See www.macromatic.com/onoff for details.

Time Delay Relays - THS-1 Series

THS-1 Series:

- ◆ Solid State Output
- ◆ Encapsulated 2" x 2" enclosure, panel mounted with one bolt or screw
- ◆ Single Function - Select from 15 Single Time or Dual Time (ON-OFF)
- ◆ Microprocessor-based design for greater performance and maximum flexibility
- ◆ Solid-state output rated 1A continuous/10A inrush is ideal for high cycle rate and long life applications
- ◆ Built-in load suppression eliminates need for separate protection
- ◆ Pilot duty rating



Single-function, solid state relays operate reliably with good accuracy in harsh environments.



THS-1 Series

SOLID STATE OUTPUT FOR HIGH CYCLE RATE AND LONG LIFE

THS-1 Series are solid state Time Delay Relays in a compact 2" x 2" enclosure. Encapsulation makes them resistant to the effects of harsh environments.

Setting the time delay is easy using the adjustable potentiometers. The microprocessor-based design provides good performance and maximum versatility.

These relays have three time delay options: on-board adjustable, on-board fixed, or remote adjustable settings.

TYPICAL MODEL CODE

THS-1 Series

Family	Function	Output Configuration	Control Voltage	Time Ranges	Standard Modifications
THS-1	Time Delay	4 1A Normally Open (Solid State)	A 24 - 240V AC D 12 - 125V DC		REMOTE POTENTIOMETER
	SINGLE TIME				
02	On Delay			-02 0.01 - 1 second	R1 100K (Std.)
05	Interval On			-04 0.05 - 5 seconds	R7 1M
08	Flasher (Off 1st)			-30 0.1 - 10 seconds	R9 2M
09	Flasher (On 1st)			-07 0.3 - 30 seconds	T Control Switch connected to Pin 2 (applies to functions 12, 13, 15, 16, 22, 41, & 65 only)
12	On Delay (Switch Trigger)			-08 0.6 - 60 seconds	Z Bulk Packaging
13	Watchdog (Switch Trigger)			-31 1 - 100 seconds	
15	Single Shot (Switch Trigger)			-09 1.2 - 120 seconds	
16	Off Delay (Switch Trigger)			-10 1.8 - 180 seconds	
22	Single Shot Falling Edge (Switch Trigger)			-12 3 - 300 seconds	
	DUAL TIME (ON-OFF)				
31	Repeat Cycle (OFF 1st)			-F Fixed Time Range (i.e., F5S for Fixed 5 seconds)	
41	On Delay / Off Delay (Switch Trigger)				
51	Repeat Cycle (On 1st)				
61	Delayed Interval				
65	Delayed Interval (Switch Trigger)				

Dual Time functions come with same ON & OFF time ranges as standard. Can be ordered in combinations of Standard or Fixed time ranges. See www.macromatic.com/onoff for details.

Time Delay Relays - THL-1 and THL-8 Series

THL-1 and THL-8 Series:

- ◆ On Delay Function
- ◆ Solid State In-line (Series Connection)
- ◆ Encapsulated 2" x 2" enclosure, panel mounted with one bolt or screw
- ◆ Microprocessor-based design for greater performance and maximum versatility
- ◆ Universal Voltage: 24-240V AC and 12-48V DC
- ◆ Solid-state output rate 1A continuous/10A inrush is ideal for high cycle rate and long life applications



Inline (series connection) On Delay function with universal input voltage.



THL-1 Series



THL-8 Series

THL-1 SERIES PROVIDES SOLID STATE, ANALOG-SET TIME DELAY

Micro-processor-based THL-1 Series Time Delay Relays provide greater performance and maximum versatility. Setting the time delay is easy using the adjustable potentiometers. The relays have three time delay options: on-board adjustable, on-board fixed, or remote adjustable time delay setting.

Encapsulation makes them resistant to the effects of harsh environments.

THL-8 SERIES PROVIDES SOLID STATE, DIGITAL-SET TIME DELAY

Inline (series connection) THL-8 Series On Delay Relays offer an easy and accurate method to select any time delay. Programming using a 10-position DIP-switch provides greater accuracy compared to units with analog potentiometers.

The relays feature a universal input voltage of 24-240V AC and 12-48V DC. The in-line two-terminal output is rated 1A continuous/10A inrush pilot duty, and is ideal for high cycle rate and long life applications.

Encapsulation makes them resistant to the effects of harsh environments.

TYPICAL MODEL CODE

THL-1 and THL-8 Series

Family		Function	Output Configuration	Input Voltage	Time Ranges	Standard Modifications		
THL-1	Time Delay - Analog Set	02 On Delay	4 SPNO	U 24-240V AC and 12-48V DC		THL-1 SERIES		
THL-8	Time Delay - Dip-Switch Digital Set					REMOTE POTENTIOMETER USES VALUES BELOW		
			THL-1 SERIES		THL-8 SERIES			
			-02	0.01 - 1 seconds	-36	10 - 1,000 seconds	-40	0.1 - 102.3 seconds
			-04	0.05 - 5 seconds	-32	0.1 - 10 minutes	-41	1 - 1,023 seconds
			-30	0.1 - 10 seconds	-15	0.3 - 30 minutes	-42	10 - 10,230 seconds
			-07	0.3 - 30 seconds	-16	0.6 - 60 minutes		
			-08	0.6 - 60 seconds	-33	1 - 100 minutes		
			-31	1 - 100 seconds	-37	10 - 1,000 minutes		
			-09	1.2 - 120 seconds	-17	0.02 - 2 hours		
			-10	1.8 - 180 seconds	-34	0.1 - 10 hours		
			-12	3 - 300 seconds	-35	1 - 100 hours		
			-F	Fixed Time Range (i.e., F5S for Fixed 5 seconds)				
								THL-8 SERIES
								Z Bulk Packaging

Time Delay Relays - TR-5 Series

TR-5 Series:

- ◆ Plug-in enclosure uses standard 8-pin or 11-pin octal sockets
- ◆ Single Function - Select from 21 Single Time or Dual Time (ON-OFF)
- ◆ On-board and remote adjustable, or fixed time delays from 50 ms to 2 hours
- ◆ 10A DPDT output contacts
- ◆ Pilot duty rating



Basic plug-in relays offer a range of single function units with analog-set time delays.



TR-5 Series

TR-5 SERIES - SINGLE FUNCTION, ANALOG-SET TIME DELAYS

TR-5 Series Relays offer reliable performance with a wide range of units with single functions. Select from 21 functions with Single Time or Dual Time (ON-OFF).

Setting the time delay is easy using the adjustable potentiometers. The microprocessor-based design provides good performance and maximum versatility.

These relays have three time delay options: on-board adjustable, on-board fixed, or remote adjustable settings from 50 ms to 2 hours.

TYPICAL MODEL CODE

TR-5 Series

Family	Function	Output Configuration	Control Voltage	Time Ranges	Standard Modifications
TR-5	Time Delay				
SINGLE TIME					
02	On Delay				
05	Interval On				
06	True Off Delay				
08	Flasher (Off 1st)				
09	Flasher (On 1st)				
12	On Delay (Switch Trigger)				
13	Watchdog (Switch Trigger)				
15	Single Shot (Switch Trigger)				
16	Off Delay (Switch Trigger)				
17	Single Shot (Power Trigger)				
18	Watchdog (Power Trigger)				
19	Off Delay (Power Trigger)				
22	Single Shot Falling Edge, Retriggerable (Switch Trigger)				
DUAL TIME (ON-OFF)					
31	Repeat Cycle (OFF 1st)				
41	On Delay / Off Delay (Switch Trigger)				
46	On Delay / True Off Delay				
51	Repeat Cycle (On 1st)				
61	Delayed Interval				
65	Delayed Interval (Switch Trigger)				
		1 240V AC			
		2 120V AC/DC			
		4 48V AC/DC (not available on Function 06 or 46)			
		6 12V DC			
		8 24V AC/DC			
			-04 0.05 - 5 seconds	-10 1.8 - 180 seconds	
			-05 0.1 - 10 seconds	-12 3 - 300 seconds	
			-07 0.3 - 30 seconds	-22 0.1 - 10 minutes	
			-08 0.6 - 60 seconds	-15 0.3 - 30 minutes	
			-09 1.2 - 120 seconds		
			-16 0.6 - 60 minutes (not available on Functions 06 or 46)		
			-17 1.2 - 120 minutes (not available on Functions 06 or 46)		
			-F Fixed Time Delay in seconds (S), minutes (M), or hours (H) (i.e., F5S = Fixed 5 seconds)		
		Dual Time Delay models are available with the same ON-OFF time ranges as standard. May be ordered special with different time ranges for ON and OFF (i.e., F5S-F10M = 5 seconds ON delay and 10 minutes OFF delay).			
		2 DPDT - Available all Functions			
		6 SPDT - Applies only to Functions 13, 15, 16, 17, 18 and 19			
			REMOTE POTENTIOMETER (Applies to all Functions except 06, 17, 18, 19 and 46. Does not apply to Functions 12, 13, 15 and 16 with SPDT.):		
			R5	500K	
			R6	750K	
			R7	1M	
			SPECIAL TRIGGER SWITCH PIN CONFIGURATION Contact your Regional Sales Manager or email sales@macromatic.com.		
			Z	Bulk Packaging	
			OUTPUT		SOCKETS (Order Separately)
			SPDT & DPDT		70169-D 8-pin
			DPDT with Trigger		70170-D 11-pin

Time Delay Relays - TR-6 Series

TR-6 Series:

- ◆ Plug-in enclosure uses standard 8-pin or 11-pin octal sockets
- ◆ Programmable Multi-Range
- ◆ 16 built-in timing ranges from 0.05 seconds - 100 hours, easily selected using a rotary switch.
- ◆ Universal Voltage: 24-240V AC and 12-125V DC
- ◆ 10A DPDT output contacts can handle most pilot duty and fractional HP loads

TR-681 and TR-682 Features

- ◆ Programmable Multi-Function
- ◆ Four or eight timing functions in one unit are selected using two rotary switches
- ◆ 16 built-in time ranges from 50 ms - 100 hours

TR-606 Features

- ◆ Programmable True Off Delay
- ◆ Eight built-in timing ranges from 50 ms - 30 minutes



with appropriate socket

Versatile relays are easily programmed for multiple functions and built-in time delays.



TR-6 Series

VERSATILE TR-6 SERIES RELAYS

TR-6 Series Relays were developed to replace hundreds of different catalog numbers, greatly reducing inventory requirements. These relays provide flexible functions, multi-range time delays, and universal input voltage.

Selecting one of 16 time ranges between 50 ms and 100 hours is easy using a rotary switch. Actual time delay is then set by adjusting a potentiometer within the selected range.

MODEL TR-681 AND TR-682

Multi-function relays are easily programmed, choosing from one of eight (TR-681) or one of four (TR-682) time delays. Two rotary switches select function and time range. The actual time delay is then set using a potentiometer.

MODEL TR-606

The TR-606 True Off Delay relay can replace the function of pneumatic time delays which are very large, expensive and inaccurate. This relay is perfect to use when a trigger switch is not available in the circuit.

TYPICAL MODEL CODE

TR-6 Series

Family	Function	Output Configuration	Control Voltage	Standard Modifications																																											
TR-6 Time Delay		2 DPDT 6 SPDT (Applies to Function 81 only)	U 24-240V AC and 12-125V DC (not available on Function 06) 1 240V AC (06 Function only) 2 120V AC/DC (06 Function only) 4 48V AC/DC (06 Function only) 6 12V DC (06 Function only) 8 24V AC/DC (06 Function only)	Z Bulk Packaging																																											
<table border="1"> <thead> <tr> <th colspan="2">SINGLE TIME</th> <th colspan="2">DUAL TIME (ON-OFF)</th> </tr> </thead> <tbody> <tr> <td>02</td> <td>On Delay</td> <td>31</td> <td>Repeat Cycle (OFF 1st)</td> </tr> <tr> <td>05</td> <td>Interval On</td> <td>41</td> <td>On Delay / Off Delay (Switch Trigger)</td> </tr> <tr> <td>06</td> <td>True Off Delay</td> <td>51</td> <td>Repeat Cycle (On 1st)</td> </tr> <tr> <td>08</td> <td>Flasher (Off 1st)</td> <td>61</td> <td>Delayed Interval</td> </tr> <tr> <td>09</td> <td>Flasher (On 1st)</td> <td>65</td> <td>Delayed Interval (Switch Trigger)</td> </tr> <tr> <td>12</td> <td>On Delay (Switch Trigger)</td> <td rowspan="5">81</td> <td rowspan="5">Eight Functions: ● On Delay ● Interval On ● Off Delay ● Single Shot ● Flasher (ON 1st) ● Single Shot Falling Edge ● Watchdog ● On Delay (Switch Trigger)</td> </tr> <tr> <td>13</td> <td>Watchdog (Switch Trigger)</td> </tr> <tr> <td>15</td> <td>Single Shot (Switch Trigger)</td> </tr> <tr> <td>16</td> <td>Off Delay (Switch Trigger)</td> </tr> <tr> <td>17</td> <td>Single Shot (Power Trigger)</td> </tr> <tr> <td>18</td> <td>Watchdog (Power Trigger)</td> <td rowspan="3">82</td> <td rowspan="3">Four Functions: ● On Delay ● Interval On ● Flasher OFF 1st ● Flasher ON 1st</td> </tr> <tr> <td>19</td> <td>Off Delay (Power Trigger)</td> </tr> <tr> <td>22</td> <td>Single Shot Falling Edge, Retriggerable (Switch Trigger)</td> </tr> </tbody> </table>		SINGLE TIME		DUAL TIME (ON-OFF)		02	On Delay	31	Repeat Cycle (OFF 1st)	05	Interval On	41	On Delay / Off Delay (Switch Trigger)	06	True Off Delay	51	Repeat Cycle (On 1st)	08	Flasher (Off 1st)	61	Delayed Interval	09	Flasher (On 1st)	65	Delayed Interval (Switch Trigger)	12	On Delay (Switch Trigger)	81	Eight Functions: ● On Delay ● Interval On ● Off Delay ● Single Shot ● Flasher (ON 1st) ● Single Shot Falling Edge ● Watchdog ● On Delay (Switch Trigger)	13	Watchdog (Switch Trigger)	15	Single Shot (Switch Trigger)	16	Off Delay (Switch Trigger)	17	Single Shot (Power Trigger)	18	Watchdog (Power Trigger)	82	Four Functions: ● On Delay ● Interval On ● Flasher OFF 1st ● Flasher ON 1st	19	Off Delay (Power Trigger)	22	Single Shot Falling Edge, Retriggerable (Switch Trigger)		
SINGLE TIME		DUAL TIME (ON-OFF)																																													
02	On Delay	31	Repeat Cycle (OFF 1st)																																												
05	Interval On	41	On Delay / Off Delay (Switch Trigger)																																												
06	True Off Delay	51	Repeat Cycle (On 1st)																																												
08	Flasher (Off 1st)	61	Delayed Interval																																												
09	Flasher (On 1st)	65	Delayed Interval (Switch Trigger)																																												
12	On Delay (Switch Trigger)	81	Eight Functions: ● On Delay ● Interval On ● Off Delay ● Single Shot ● Flasher (ON 1st) ● Single Shot Falling Edge ● Watchdog ● On Delay (Switch Trigger)																																												
13	Watchdog (Switch Trigger)																																														
15	Single Shot (Switch Trigger)																																														
16	Off Delay (Switch Trigger)																																														
17	Single Shot (Power Trigger)																																														
18	Watchdog (Power Trigger)	82	Four Functions: ● On Delay ● Interval On ● Flasher OFF 1st ● Flasher ON 1st																																												
19	Off Delay (Power Trigger)																																														
22	Single Shot Falling Edge, Retriggerable (Switch Trigger)																																														
			<table border="1"> <thead> <tr> <th>FUNCTION</th> <th>SOCKETS</th> </tr> </thead> <tbody> <tr> <td>SPDT & DPDT</td> <td>70169-D 8-pin - Order Separately</td> </tr> <tr> <td>DPDT with Trigger</td> <td>70170-D 11-pin - Order Separately</td> </tr> </tbody> </table>	FUNCTION	SOCKETS	SPDT & DPDT	70169-D 8-pin - Order Separately	DPDT with Trigger	70170-D 11-pin - Order Separately																																						
FUNCTION	SOCKETS																																														
SPDT & DPDT	70169-D 8-pin - Order Separately																																														
DPDT with Trigger	70170-D 11-pin - Order Separately																																														

Time Delay Relays - TD-7 Series

TD-7 Series:

- ◆ Plug-in enclosure uses standard 8-pin or 11-pin octal sockets
- ◆ Ten user-selectable functions in one unit
- ◆ Digital setting of time delay with 4 pushbutton thumb-wheels
- ◆ 50ms - 999 hour programmable time range
- ◆ 10A DPDT output contacts
- ◆ LED indicates timing mode and time out conditions
- ◆ Pilot duty rating

TD-781 Features

- ◆ Ten built-in functions in one unit are selected using a fifth pushbutton thumb-wheel.



Digital setting of function and time delay is easy with pushbutton thumb-wheels.



TD-7 Series

DIGITAL INPUT FOR GREATER ACCURACY THAN ANALOG INPUT

TD-7 Series Relays offer an easy and accurate way to select any time delay between 50 ms and 999 hours. A pushbutton thumb-wheel is used to select one of seven built-in time ranges. Three pushbutton thumb wheels digitally set the time delay required.

This method provides a greater setting accuracy compared to units with an analog potentiometer.

An LED indicates timing mode and time out condition.

MODEL TD-781 PROVIDES TEN SELECTABLE FUNCTIONS IN ONE UNIT

These multi-function units have a fifth pushbutton thumb wheel to select one of ten built-in functions. Like other models in the TD-7 Series, an LED indicates timing mode and time out condition. It also has a pilot duty rating.

TYPICAL MODEL CODE

TD-7 Series

Family	Function	Output Configuration	Control Voltage	Standard Modifications						
TD-7	Time Delay	2 DPDT 6 SPDT (Applies to 12, 13, 15, 16, 22 and 81 Functions only)	1 240V AC 2 120V AC/DC 4 48V AC/DC 6 12V DC 8 24V AC/DC	Z Bulk Packaging						
02	On Delay	<table border="1"> <thead> <tr> <th>FUNCTION</th> <th>SOCKETS</th> </tr> </thead> <tbody> <tr> <td>SPDT & DPDT</td> <td>70169-D 8-pin - Order Separately</td> </tr> <tr> <td>DPDT with Trigger</td> <td>70170-D 11-pin - Order Separately</td> </tr> </tbody> </table>	FUNCTION	SOCKETS	SPDT & DPDT	70169-D 8-pin - Order Separately	DPDT with Trigger	70170-D 11-pin - Order Separately		
FUNCTION	SOCKETS									
SPDT & DPDT	70169-D 8-pin - Order Separately									
DPDT with Trigger	70170-D 11-pin - Order Separately									
05	Interval On									
08	Flasher (Off 1st)									
09	Flasher (On 1st)									
12	On Delay (Switch Trigger)									
13	Watchdog (Switch Trigger)									
15	Single Shot (Switch Trigger)									
16	Off Delay (Switch Trigger)									
22	Single Shot Falling Edge, Retriggerable (Switch Trigger)									
41	On Delay / Off Delay (Switch Trigger)									
	Multi-Function (10 Functions)									
	81									
	<ul style="list-style-type: none"> • On Delay • Interval On • Off Delay • Single Shot • Flasher (OFF 1st) • Flasher (ON 1st) • On/Off Delay • Single Shot Falling Edge • Watchdog • Triggered On Delay 									

Time Delay Relays - TD-8 Series

TD-8 Series:

- ◆ Plug-in enclosure uses standard 8-pin or 11-pin octal sockets
- ◆ DIP-switches for accurate digital setting of time delay
- ◆ Programmable from 0.05 seconds - 10,230 hours
- ◆ 10A DPDT output contacts
- ◆ LED indicates relay status
- ◆ Pilot duty rating

TD-881 Features

- ◆ Sixteen built-in functions are user-selectable using two 10-position DIP-switches



Dip-switches provide ultimate flexibility and digital accuracy.



TD-8 Series

SINGLE-FUNCTION RELAYS ARE EASY TO PROGRAM

TD-8 Series Time Delay Relays are easy to accurately select any time delay between 0.1 seconds and 1,023 hours.

Programming is accomplished using a 10-position DIP-switch. Each position is marked with a binary time increment. The required delay is selected by moving the switch of each increment to the ON position and adding their corresponding values.

MULTI-FUNCTION MODEL TD-881 CAN REDUCE INVENTORY

Two 10-position DIP-switches provide an easy and accurate method to select any of 16 time delay functions and any time delay between 0.05 seconds and 10,230 hours (310 hours for Dual Mode functions).

The TD-881 relays can replace hundreds of different catalog numbers, greatly reducing inventory requirements. Refer to the online programming tool at:

macromatic.com/blog/relays/dip-switch-programming

TYPICAL MODEL CODE

TD-8 Series

Family	Function	Output Configuration	Control Voltages	Time Ranges	Standard Modifications							
TD-8	Time Delay											
02	On Delay	2 DPDT 6 SPDT (Applies to 12, 13, 15, 16, 22 and 81 Functions only)	1 240V AC 2 120V AC/DC 4 48V AC/DC 6 12V DC 8 24V AC/DC	Not required for Multi-function 81 -40 0.1 - 102.3 seconds -41 1 - 1,023 seconds -42 1 - 10,230 seconds -43 1 - 1,023 minutes -44 10 - 10,230 minutes -45 1 - 1,023 hours	Special internal jumper connection with 5-6 trigger to match equivalent products from SSAC and Infitec (Applies to Functions 15, 16, 41 and 81 only): SPDT 8 PIN: T14 Internal Jumper Pins 2-6 DPDT 11 PIN: T15 Internal Jumper Pins 2-5 Z Bulk Packaging							
05	Interval On					81						
08	Flasher (Off 1st)						SINGLE TIME: <ul style="list-style-type: none"> On Delay Interval On Flasher (OFF 1st) Flasher (ON 1st) Off Delay Single Shot Watchdog Single Shot (Trailing Edge) Triggered on Delay 					
09	Flasher (On 1st)											
12	On Delay (Switch Trigger)											
13	Watchdog (Switch Trigger)											
15	Single Shot (Switch Trigger)											
16	Off Delay (Switch Trigger)											
22	Single Shot Falling Edge, Retriggerable (Switch Trigger)							DUAL TIME OFF: DUAL TIME (ON-OFF): <ul style="list-style-type: none"> Repeat Cycle (OFF 1st) Repeat Cycle (ON 1st) Delayed Interval Triggered Delayed Interval On/Off Delay Single Shot - Flasher On Delay / Flasher 				
31	Repeat Cycle (OFF 1st)											
41	On Delay / Off Delay (Switch Trigger)											
51	Repeat Cycle (ON 1st)											
61	Delayed Interval											
65	Delayed Interval (Switch Trigger)											
		<table border="1"> <thead> <tr> <th>OUTPUT</th> <th>SOCKETS</th> </tr> </thead> <tbody> <tr> <td>SPDT & DPDT</td> <td>70169-D 8-pin - Order Separately</td> </tr> <tr> <td>DPDT with Trigger</td> <td>70170-D 11-pin - Order Separately</td> </tr> </tbody> </table>		OUTPUT	SOCKETS				SPDT & DPDT	70169-D 8-pin - Order Separately	DPDT with Trigger	70170-D 11-pin - Order Separately
OUTPUT	SOCKETS											
SPDT & DPDT	70169-D 8-pin - Order Separately											
DPDT with Trigger	70170-D 11-pin - Order Separately											

Time Delay Relays - TE5 Series

TE5 Series:

- ◆ Slim 17.5mm slim design for compact DIN Rail mounting
- ◆ 10 A SPDT OR DPDT outputs available
- ◆ 15 Time Delay Functions available
- ◆ Universal Control Voltage: 24V -240V AC & 12-240V DC
- ◆ Adjustable factory fixed time ranges from 50ms to 100 hours
- ◆ LEDs indicate output relay status and timing mode



Time Delay Relays provide a simple solution for automation, motor control, energy efficiency, and many more applications.



TE5 Series

The TE5 Series of 17.5MM time delay relays provide precise time-based control in a compact package, saving valuable space. Each product has a single dedicated function and time range so there is no complicated setup required before use. Time delays from 0.05 seconds up to 100 hours can be accomplished across 17 user-adjustable time ranges, or factory fixed times (non-adjustable) are also available. Select from 15 unique timing functions to meet your specific control and automation needs.

TYPICAL MODEL CODE

TE5 Series

Family		Function	Output Configuration	Control Voltage	Time Ranges	Standard Modifications
TE5	17.5 MM Time Delay	SINGLE TIME 02 On Delay 05 Interval On 08 Flasher (Off 1st) 09 Flasher (On 1st) 12 On Delay (Triggered) 13 Watchdog (Triggered) 15 Single Shot (Triggered) 16 Off Delay (Triggered) 22 Single Shot Falling Edge (Triggered) 29 Memory Latch (Triggered) Dual Time 31 Repeat Cycle (OFF 1st) 41 On Delay/Off Delay (Triggered) 51 Repeat Cycle (ON 1st) 61 Delayed Interval 65 Delayed Interval (Triggered)	2 DPDT 6 SPDT	U 24-240V AC, 12-240V DC	-04 0.05 - 5 seconds -30 0.1 - 10 seconds -07 0.3 - 30 seconds -08 0.6 - 60 seconds -31 1 - 100 seconds -09 1.2 - 120 seconds -10 1.8 - 180 seconds -12 3 - 300 seconds -36 10 - 1,000 seconds -32 0.1 - 10 minutes -15 0.3 - 30 minutes -16 0.6 - 60 minutes -33 1-100 minutes -37 10 - 1,000 minutes -17 1.2 - 120 minutes -34 0.1 - 10 hours -35 1 - 100 hours -F Fixed Time Range (i.e., F5S for Fixed 5 seconds)	Z Bulk Packaging

Time Delay Relays - TE-881 and TE-6 Series

TE-881 Series:

- ◆ Narrow 17.5 mm enclosure mounts on 35mm DIN-rail
- ◆ Ten field-selectable functions in one unit
- ◆ Universal Input Voltage: 12 - 240V AC/DC
- ◆ Programmable time delay from 0.1 second - 10 days
- ◆ 15A SPDT or DPDT output contacts

TE-6 Series:

- ◆ Narrow 17.5 mm enclosure mounts on 35mm DIN-rail
- ◆ Single function simplifies set-up
- ◆ Universal Input Voltage: 12 - 240V AC/DC
- ◆ Programmable time delay from 0.1 second - 10 days
- ◆ 15A SPDT output contacts



Versatile relays with DIN-rail mounting conserve space and reduce installation time.



TE-881 Series



TE-6 Series

SELECT FROM MULTI-FUNCTION OR SINGLE FUNCTION RELAYS

These narrow DIN-Rail mounted Time Delay Relays feature universal voltage input (12-240V AC/DC) with a programmable time range from 0.1 second to 10 days. LEDs indicates output relay status and timing modes.

The TE-881 Series provides ten programmable timing functions with 15A SPDT or DPDT output contacts. These versatile relays can replace hundreds of separate time delay relays.

The TE-6 Series are single-function ON Delay or OFF Delay (Switch Trigger) relays that simplify set-up and troubleshooting.

TYPICAL MODEL CODE

TE-881 Series

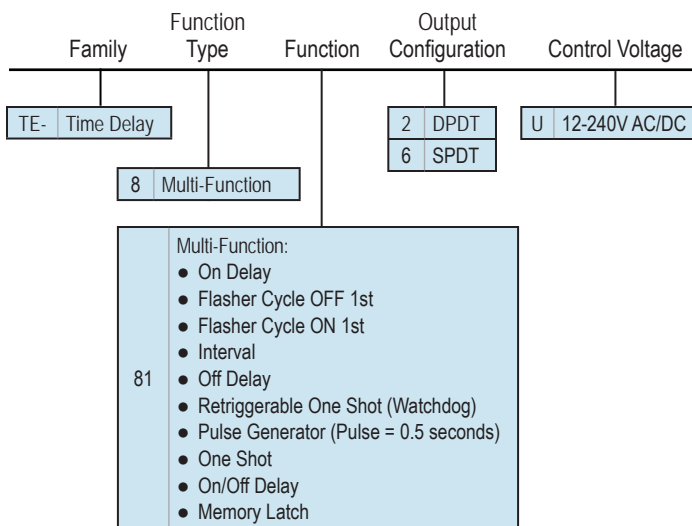

TE-6 Series

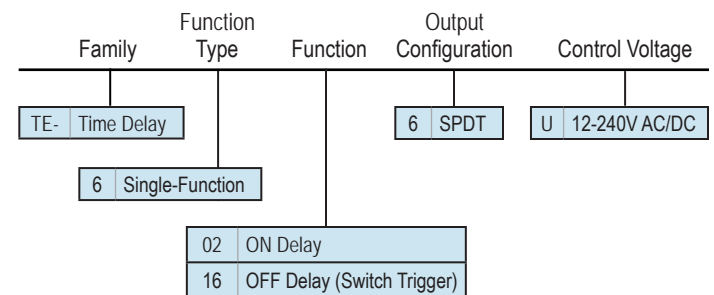

Time Delay Relays - TAD and TAA Series

TAD Series:

- ◆ 1/16 DIN-style case (48 mm wide) includes adapter for panel or surface mounting
- ◆ Push-button thumb-wheels for digital-setting of time delay & selection of function
- ◆ 10 field-selectable functions in one unit
- ◆ Programmable from 0.05 seconds to 9,990 hours

TAA Series:

- ◆ 1/16 DIN-style case (48 mm wide) includes adapter for panel or surface mounting
- ◆ Six built-in user-selectable functions in one unit
- ◆ Large dial for setting time delay
- ◆ Programmable from 0.05 seconds to 100 hours



Relays provide easy 1/16 DIN mounting and accurate set-up with large displays.



TAD Series

TAD Series Relays include 10 selectable functions in one unit. Setting the time delay is easy with push-button thumb-wheels.

The LED display shows time remaining in both digit and bar graph form. It also indicates relay status and time base. A switch on the bottom of the unit allows a choice of timing up or timing down display.



TAA Series

TAA Series Time Delay Relays include six built-in functions. A large dial is used to set the time delay.

One red LED indicates Voltage/Timing (flashing) and a second red LED indicates relay status.

TYPICAL MODEL CODE

TAD Series

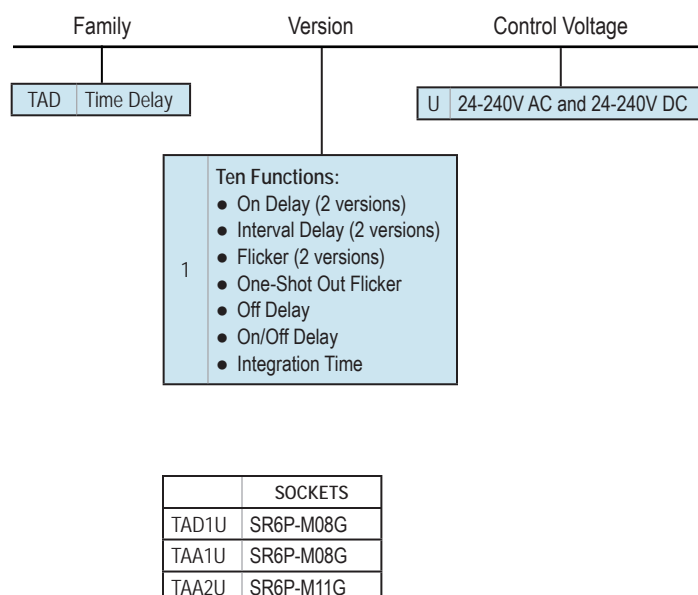

TAA Series

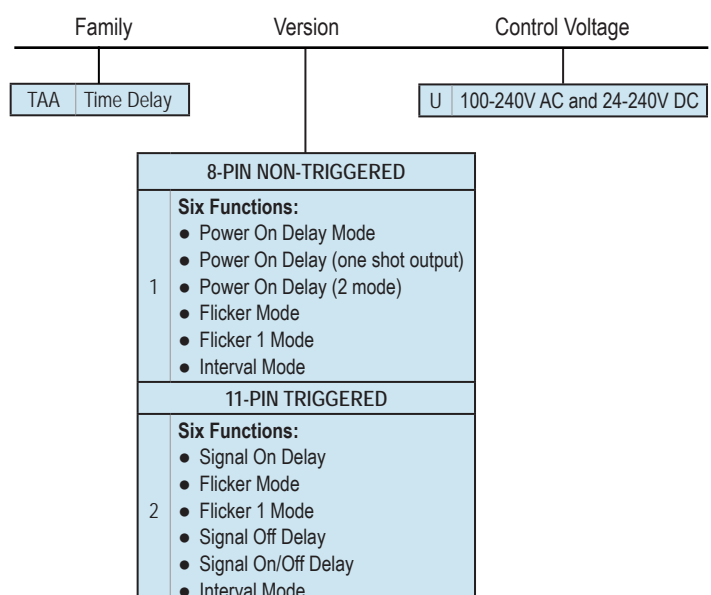



Proudly Manufactured in **Waukesha, WI.**

OTHER OFFERINGS - SOCKETS & ACCESSORIES

Macromatic offers a complete line of accessories that work with our products. Sockets simplify relay installation and replacement. Other accessories include retainers and hold-down springs, terminal covers, and replacement terminals.

SOCKETS



Industry standard 8-pin and 11-pin octal sockets, and 12-pin square sockets simplify relay installation. Back-mounted sockets allow flange style enclosures to be panel mounted.

OTHER ACCESSORIES



Accessories include retainers and hold-down springs, terminal covers, and replacement terminals.



www.macromatic.com

800.238.7474



Your source for quality, innovative industrial control solutions

Macromatic Industrial Controls, Inc. designs and manufactures control, monitoring and protection products to manage your electrical processes and to protect your equipment from damaging fault conditions.

With a 49-year legacy of high-quality products and outstanding customer service, we continue to introduce innovative solutions that help our customers be more productive and efficient.

Our design and application experience makes it easy to find cost-effective advantages for your applications.

As your source for quality, innovative industrial control solutions, we offer you:

- Engineering and design assistance for unique applications
- Quick turnaround on prototypes and production
- Knowledge to obtain agency approval on your custom products
- The best technical support in the industry

We continuously improve our products by integrating new technology and improving our manufacturing processes. The result is innovative, reliable products, delivered on-time, every time.



Better. By Design.

Macromatic Industrial Controls, Inc. • 2201 Corporate Drive • Waukesha, WI 53189
800.238.7474 • 262.781.3366 • sales@macromatic.com • www.macromatic.com

LSGAZ00AEN0922

Distributed by Gross Automation | +1 (262) 252-1600 | sales@grossautomation.com