



Industrial Control & Monitoring Products



Better. By Design.

Distributed by Gross Automation | +1 (262) 252-1600 | sales@grossautomation.com.

About Macromatic

Macromatic is a highly responsive, independently owned provider of Industrial Control & Monitoring products. Our goal is simple: to establish long-term customer value through proven quality products, continuous customer support & superior performance. With over 30 years of experience, we have tailored our capabilities to accommodate your special requirements. We make it easy for you to do business with Macromatic.



Why Work With Us?

- ▶ *Five Year Warranty*
- ▶ *Short lead-times*
- ▶ *Superior customer service*
- ▶ *Advanced technical support*
- ▶ *Products meet UL and CE*
- ▶ *RoHS manufacturing*





PRODUCT INDEX

Index by Product Number	4
Phase Monitor Relays	
Product Summary	5
PCP Series Phase Reversal	6-7
PLP Series Phase Loss & Phase Reversal	8-9
PAP Series Phase Loss, Phase Reversal & Undervoltage	10-11
PMP Series Phase Loss, Phase Reversal, Phase Unbalance, Undervoltage & Overvoltage	12-13
PMP-FA Series Phase Loss, Phase Reversal, Phase Unbalance, Under/Over Voltage	14-15
PMD Series Phase Loss, Phase Reversal, Phase Unbalance, Undervoltage & Overvoltage	16-17
Current Monitor Relays	
Product Summary	18-19
CM Series Standard	20-21
CO Series Overcurrent	22-23
CU Series Undercurrent	24-25
Voltage Monitor Relays	
Product Summary	26-27
VM Series Over/Under Voltage (Fixed Time Delay on Drop-Out) 12-120V	28-29
VA Series Over/Under Voltage (Adjustable Time Delay on Drop-Out) 12-120V	30-31
VW Series Voltage Band (Window) 12-120V	32-33
VAK Series Over/Under Voltage 208-240V	34-35
VWK Series Voltage Band & Three Phase Voltage Band 208-240V	36-39
VAKE Series Over/Under Voltage 17.5mm	40
VWKE Series Voltage Band 17.5mm	41
Alternating Relays	
SPDT & DPDT	42-43
DPDT Cross-Wired	44-45
Pump Seal Failure Relays	
Single & Dual Channel	46-47
Intrinsically Safe Relays	
Single Channel	48-49
Time Delay Relays	
Product Summary	50-51
Definition of Timing Functions	52-53
TR-6 Series <i>Time Ranger</i> Programmable Multi-Range	54-59
TR-5 Series Non-Programmable DPDT	60-63
TR-5 Series Non-Programmable 8 Pin SPDT	64-65
SS-6 & -8 Series Compact Non-Programmable	66
SS-4 Series Non-Programmable with Quick Connect Terminals	67
TD-7 Series <i>Time Ranger</i> Digital-Set Programmable	68-69
TD-8 Series <i>Time Ranger</i> DIP-Switch Digital-Set Programmable	70-73
TAD Series Digital-Set & TAA Series Analog-Set Multi-Function Multi-Range	74-77
TE-881 Series Programmable Multi-Function Multi Range 17.5mm	78-79
Standard Modifications for Time Delay Relays	80
Sockets & Accessories	81-82

Since we continuously strive to improve and update our product offering, specifications are subject to change without notice.

"Macromatic" & *"Time Ranger"* are Registered Tradenames of Macromatic Industrial Controls Inc.

INDEX BY PRODUCT NUMBER

Product *	Page	Product *	Page	Product *	Page	Product *	Page	Product *	Page	Product *	Page
27390D	82	COKP05A68	22	SFP240A100	46	TD-81621-xx	71	TR-51922-xx	61	TR-66121	56
70100	52	COKP10A22	22	SFP240A250	46	TD-81622-xx	71	TR-51926-xx	61	TR-66122	56
70166	82	COKP10A28	22	SFP240B025	46	TD-81626-xx	71	TR-51928-xx	61	TR-66126	56
70169-D	81	COKP10A62	22	SFP240B100	46	TD-81628-xx	71	TR-51961-xx	64	TR-66128	56
70170-D	81	COKP10A68	22	SFP240B250	46	TD-83121-xx	71	TR-51962-xx	64	TR-66521	56
70171-D	81	COP01A22	22	SFP240C025	46	TD-83122-xx	71	TR-51966-xx	64	TR-66522	56
70400	82	COP01A28	22	SFP240C100	46	TD-83126-xx	71	TR-51968-xx	64	TR-66526	56
ARP012A2	42	COP01A62	22	SFP240C250	46	TD-83128-xx	71	TR-53121-xx	62	TR-66528	56
ARP012A2R	42	COP01A68	22	SR6P-M08G	81	TD-85121-xx	71	TR-53122-xx	62	TR-68129	**
ARP012A3	44	COP05A22	22	SR6P-M11G	81	TD-85122-xx	71	TR-53126-xx	62	TR-68169	**
ARP012A3R	44	COP05A28	22	SS-3 (Any)	**	TD-85126-xx	71	TR-53128-xx	62	VAKE024D	40
ARP012A5	44	COP05A62	22	SS-40222-xx	67	TD-85128-xx	71	TR-55121-xx	62	VAKE120A	40
ARP012A5R	44	COP05A68	22	SS-40228-xx	67	TD-88121	70	TR-55122-xx	62	VAKE240A	40
ARP012A6	42	COP10A22	22	SS-41622-xx	67	TD-88122	70	TR-55126-xx	62	VAKP012D	30
ARP012A6R	42	COP10A28	22	SS-41628-xx	67	TD-88126	70	TR-55128-xx	62	VAKP024A	30
ARP024A2	42	COP10A62	22	SS-6262-xx	66	TD-88128	70	TR-56121-xx	62	VAKP024D	30
ARP024A2R	42	COP10A68	22	SS-6266-xx	66	TE-8816U	78	TR-56122-xx	62	VAKP048D	30
ARP024A3	44	CUP01A22	24	SS-6268-xx	66	TR-50221-xx	60	TR-56126-xx	62	VAKP110D	30
ARP024A3R	44	CUP01A28	24	SS-70166	***	TR-50222-xx	60	TR-56128-xx	62	VAKP120A	30
ARP024A5	44	CUP01A62	24	SS-8062-xx	66	TR-50226-xx	60	TR-56521-xx	62	VAKPU	34
ARP024A5R	44	CUP01A68	24	SS-8066-xx	66	TR-50228-xx	60	TR-56522-xx	62	VAP012D	30
ARP024A6	42	CUP05A22	24	SS-8068-xx	66	TR-50521-xx	60	TR-56526-xx	62	VAP024A	30
ARP024A6R	42	CUP05A28	24	SS-8162-xx	**	TR-50522-xx	60	TR-56528-xx	62	VAP024D	30
ARP120A2	42	CUP05A62	24	SS-8166-xx	**	TR-50526-xx	60	TR-60221	54	VAP048D	30
ARP120A2R	42	CUP05A68	24	SS-8168-xx	**	TR-50528-xx	60	TR-60222	54	VAP110D	30
ARP120A3	44	CUP10A22	24	SS-8562-xx	66	TR-50821-xx	60	TR-60226	54	VAP120A	30
ARP120A3R	44	CUP10A28	24	SS-8566-xx	66	TR-50822-xx	60	TR-60228	54	VMKP012D	28
ARP120A5	44	CUP10A62	24	SS-8568-xx	66	TR-50826-xx	60	TR-60521	54	VMKP024A	28
ARP120A5R	44	CUP10A68	24	SS-8762-xx	66	TR-50828-xx	60	TR-60522	54	VMKP024D	28
ARP120A6	42	ISP024A	48	SS-8766-xx	66	TR-51321-xx	61	TR-60526	54	VMKP048D	28
ARP120A6R	42	ISP120A	48	SS-8768-xx	66	TR-51322-xx	61	TR-60528	54	VMKP110D	28
ARP240A2	42	PAP120	10	TAA1U	76	TR-51326-xx	61	TR-60621	58	VMKP120A	28
ARP240A2R	42	PAP208	10	TAA2U	76	TR-51328-xx	61	TR-60622	58	VMP012D	28
ARP240A3	44	PAP240	10	TAD1U	74	TR-51361-xx	64	TR-60628	58	VMP024A	28
ARP240A3R	44	PAP400	10	TD-70221	68	TR-51362-xx	64	TR-60821	54	VMP024D	28
ARP240A5	44	PAP480	10	TD-70222	68	TR-51366-xx	64	TR-60822	54	VMP048D	28
ARP240A5R	44	PCP1	6	TD-70226	68	TR-51368-xx	64	TR-60826	54	VMP110D	28
ARP240A6	42	PCP2	6	TD-70228	68	TR-51521-xx	61	TR-60828	54	VMP120A	28
ARP240A6R	42	PLP120	8	TD-70521	68	TR-51522-xx	61	TR-61321	55	VWKE024D	41
CMKP01A22	20	PLP208	8	TD-70522	68	TR-51526-xx	61	TR-61322	55	VWKE120A	41
CMKP01A28	20	PLP240	8	TD-70526	68	TR-51528-xx	61	TR-61326	55	VWKE240A	41
CMKP01A62	20	PLP400	8	TD-70528	68	TR-51561-xx	64	TR-61328	55	VWKP012D	32
CMKP01A68	20	PLP480	8	TD-70821	68	TR-51562-xx	64	TR-61521	55	VWKP024A	32
CMKP05A22	20	PMD120	16	TD-70822	68	TR-51566-xx	64	TR-61522	55	VWKP024D	32
CMKP05A28	20	PMD208	**	TD-70826	68	TR-51568-xx	64	TR-61526	55	VWKP048D	32
CMKP05A62	20	PMD240	**	TD-70828	68	TR-51621-xx	61	TR-61528	55	VWKP110D	32
CMKP05A68	20	PMD400	**	TD-71521	68	TR-51622-xx	61	TR-61621	55	VWKP120A	32
CMKP10A22	20	PMD480	**	TD-71522	68	TR-51626-xx	61	TR-61622	55	VWKP120A	32
CMKP10A28	20	PMD600	16	TD-71526	68	TR-51628-xx	61	TR-61626	55	VWKP120A	32
CMKP10A62	20	PMDU	16	TD-71528	68	TR-51661-xx	64	TR-61628	55	VWKP120A	32
CMKP10A68	20	PMP120	12	TD-71621	68	TR-51662-xx	64	TR-61721	55	VWKP120A	32
CMP01A22	20	PMP208	**	TD-71622	68	TR-51666-xx	64	TR-61722	55	VWKP120A	32
CMP01A28	20	PMP208-FA11	14	TD-71626	68	TR-51668-xx	64	TR-61726	55	VWKP120A	32
CMP01A62	20	PMP240	**	TD-71628	68	TR-51721-xx	61	TR-61728	55	VWKP120A	32
CMP01A68	20	PMP240-FA11	14	TD-78121	68	TR-51722-xx	61	TR-61821	55	VWKP120A	32
CMP05A22	20	PMP480	**	TD-78122	68	TR-51726-xx	61	TR-61822	55	VWKP120A	32
CMP05A28	20	PMPU	12	TD-78126	68	TR-51728-xx	61	TR-61826	55	VWKP120A	32
CMP05A62	20	PMPU-FA12	14	TD-78128	68	TR-51761-xx	64	TR-61828	55	VWKP120A	32
CMP05A68	20	PMPU-FA8	14	TD-80221-xx	71	TR-51762-xx	64	TR-61921	55	VWKP120A	32
CMP10A22	20	PMPU-FA8X	14	TD-80222-xx	71	TR-51766-xx	64	TR-61922	55	VWKP120A	32
CMP10A28	20	SFP120A025	46	TD-80226-xx	71	TR-51768-xx	64	TR-61926	55	VWKP120A	32
CMP10A62	20	SFP120A100	46	TD-80228-xx	71	TR-51821-xx	61	TR-61928	55	VWKP120A	32
CMP10A68	20	SFP120A250	46	TD-80521-xx	71	TR-51822-xx	61	TR-63121	56	VWKP120A	32
COKP01A22	22	SFP120B025	46	TD-80522-xx	71	TR-51826-xx	61	TR-63122	56	VWKP120A	32
COKP01A28	22	SFP120B100	46	TD-80526-xx	71	TR-51828-xx	61	TR-63126	56	VWKP120A	32
COKP01A62	22	SFP120B250	46	TD-80528-xx	71	TR-51861-xx	64	TR-63128	56	VWKP120A	32
COKP01A68	22	SFP120C025	46	TD-81521-xx	71	TR-51862-xx	64	TR-65121	56	VWKP120A	32
COKP05A22	22	SFP120C100	46	TD-81522-xx	71	TR-51866-xx	64	TR-65122	56	VWKP120A	32
COKP05A28	22	SFP120C250	46	TD-81526-xx	71	TR-51868-xx	64	TR-65126	56	VWKP120A	32
COKP05A62	22	SFP240A025	46	TD-81528-xx	71	TR-51921-xx	61	TR-65128	56	VWKP120A	32

* The "-xx" suffix denotes the time range for non-programmable time delay relays.

** Contact Macromatic for more information.

PHASE MONITOR RELAYS

PRODUCT SUMMARY



Phase Monitor Relays provide protection against premature equipment failure caused by voltage faults on 3 Phase systems. All Macromatic Phase Monitor Relays are designed to be compatible with most Wye or Delta systems. In Wye systems, a connection to a neutral is not required. Phase Monitor Relays protect against single phasing regardless of any regenerative voltages.

The Reference Guide below provides general information on the different versions of Phase Monitor Relays offered by Macromatic (see Product Selection on the following pages for further details):

Series	Mounting Style	Phase Loss	Phase Reversal	Phase Unbalance	Under Voltage	Over Voltage	Time Delay on Undervoltage	Approvals *	See Page
PCP	Plug-in *		✓					UL US	6
PLP	Plug-in *	✓	✓					UL US	8
PAP	Plug-in *	✓	✓		✓ (adj.)		50ms fixed	UL US	10
PMP	Plug-in *	✓	✓	✓ (adj.)	✓ (adj.)	✓ (fixed)	0.1 - 20 sec.	UL US CE	12
PMP-FA	Plug-in *	✓	✓	✓ (fixed)	✓ (fixed)	✓ (fixed)	4 seconds fixed	UL US CE	14
PMD	Surface	✓	✓	✓ (adj.)	✓ (adj.)	✓ (fixed)	0.1 - 20 sec.	UL US CE	16

* In addition to the above approvals, all Plug-in Products are also UL Listed when used with the appropriate Macromatic socket.

PROTECTION

Depending on the unit selected, it will protect three phase equipment against:

- ◆ **phase loss** - total loss of one or more of the three phases. Also known as "single phasing." Typically caused by a blown fuse, broken wire, or worn contact. This condition would result in a motor drawing locked rotor current during start-up. In addition, a three phase motor will continue to run after losing a phase, resulting in possible motor burn-out.
- ◆ **phase reversal** - reversing any two of the three phases will cause a three phase motor to run in the opposite direction. This may cause damage to driven machinery or injury to personnel. The condition usually occurs as a result of mistakes made during routine maintenance or when modifications are made to the circuit.
- ◆ **phase unbalance** - unbalance of a three phase system occurs when single phase loads are connected such that one or two of the lines (phases) carry more or less of the load. This could cause motors to run at temperatures above published ratings.
- ◆ **undervoltage** - when voltage in all three lines of a three phase system drop simultaneously.
- ◆ **overvoltage** - when voltage in all three lines of a three phase system increase simultaneously.

TYPICAL CONNECTIONS

Line Side Monitoring

With the relay connected before the motor starter, the motor can be started in the reverse direction. However, the motor is unprotected against phase failures between the relay and the motor.

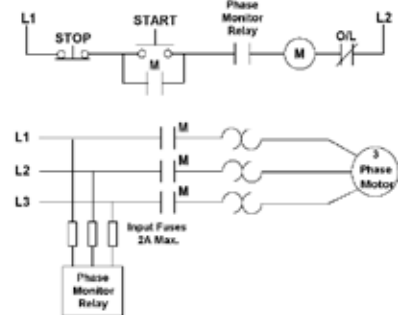

Load Side Monitoring

With the relay connected directly to the motor, the total feed lines are monitored. This connection should not be used with reversing motors.

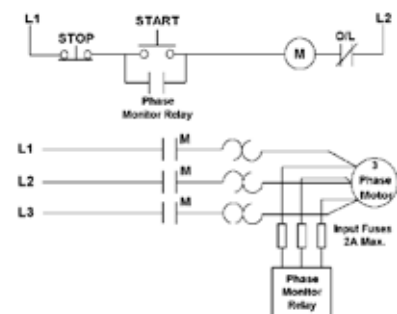

PHASE MONITOR RELAYS

PHASE REVERSAL ONLY PCP SERIES PLUG-IN



- ◆ Protects against phase reversal
- ◆ One version works on 208-480V 3 Phase Systems
- ◆ LED indicates both normal and fault conditions
- ◆ Compact plug-in case utilizing industry-standard 8 pin octal socket
- ◆ 10A SPDT output contacts
- ◆  (with appropriate socket)

The PCP Series Phase Monitor Relays provide protection against phase reversal in a compact plug-in design. One version will work on any 3 phase system from 208V to 480V (a separate 120V-only version is also available). These devices are designed to be compatible with most Wye or Delta systems. In Wye systems, a connection to a neutral is not required.

The relay is energized and the LED on when the sequence is correct. Any fault will de-energize the relay and turn off the LED. Re-energization is automatic upon correction of the fault condition.

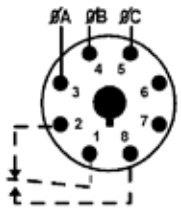
MOUNTING STYLE	NOMINAL VOLTAGE 50/60 Hz	PRODUCT NUMBER	WIRING/SOCKET ■
Plug-in	120V	PCP1	8 Pin Octal 70169-D  DIAGRAM 23
	208-480V	PCP2 *	

* Requires a 600V-rated socket when used on system voltages greater than 300V.

■ See Pages 81 & 82 for **Sockets & Accessories**.



800-238-7474

www.macromatic.com
sales@macromatic.com

PHASE MONITOR RELAYS

PHASE REVERSAL ONLY PCP SERIES PLUG-IN APPLICATION DATA & DIMENSIONS

APPLICATION DATA

Phase Reversal:

Unit trips if sequence of the three phases is anything other than A-B-C.

Output Contacts:

10A Resistive SPDT @ 240V AC, 1/3HP @ 120/240V AC (N.O.), 1/6HP @ 120/240V AC (N.C.)

Life:

Full Load: 100,000 operations

Response Times:

Operate: 50ms

Release: 50ms

Load (Burden):

3VA

Temperature:

-28° to 65°C (-20° to 150°F)

Transient Protection:

10,000 volts for 20 microseconds

Mounting:

Uses an 8 pin octal socket. Requires a 600V-rated socket when used on system voltages greater than 300V (Macromatic Product Number 70169-D--see Page 81).

Indicator LED:

Red LED on when all conditions are normal, and off when a fault condition has occurred.

Reset:

Automatic upon correction of fault

Approvals:



DIMENSIONS

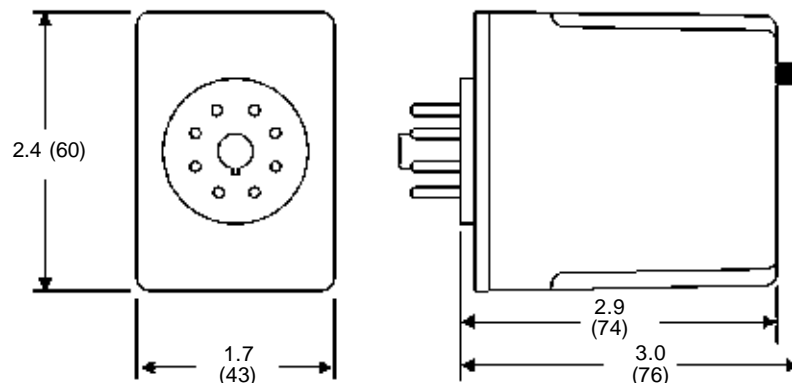

All Dimensions in
Inches (Millimeters)

PHASE MONITOR RELAYS

PHASE LOSS & PHASE REVERSAL PLP SERIES PLUG-IN



- ◆ Protects against phase loss & phase reversal
- ◆ LED indicates both normal and fault conditions
- ◆ Compact plug-in case utilizing industry-standard 8 pin octal socket
- ◆ 10A SPDT output contacts
- ◆  (with appropriate socket)

The PLP Series Phase Monitor Relays provide protection against phase loss & phase reversal in a compact plug-in design. These devices are designed to be compatible with most Wye or Delta systems. In Wye systems, a connection to a neutral is not required. Phase Monitor Relays protect against single phasing regardless of any regenerative voltages.

The relay is energized and the LED on when all three phases are present and in the correct sequence. Any fault will instantaneously de-energize the relay and turn off the LED. Re-energization is automatic upon correction of the fault condition.

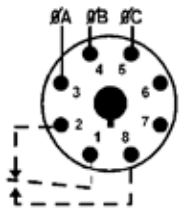
MOUNTING STYLE	NOMINAL VOLTAGE 50/60 Hz	PRODUCT NUMBER	WIRING/SOCKET ■
Plug-in	120V	PLP120	8 Pin Octal 70169-D  DIAGRAM 23
	208V	PLP208	
	240V	PLP240	
	400V	PLP400 *	
	480V	PLP480 *	

* Requires a 600V-rated socket when used on system voltages greater than 300V.
 ■ See Pages 81 & 82 for **Sockets & Accessories**.



800-238-7474

www.macromatic.com
sales@macromatic.com

PHASE MONITOR RELAYS

PHASE LOSS & PHASE REVERSAL

PLP SERIES PLUG-IN

APPLICATION DATA & DIMENSIONS

APPLICATION DATA

Phase Loss:

Unit trips on loss of any Phase A, B or C

Phase Reversal:

Unit trips if sequence of the three phases is anything other than A-B-C.

Output Contacts:

10A Resistive SPDT @ 240V AC, 1/3HP @ 120/240V AC (N.O.), 1/6HP @ 120/240V AC (N.C.)

Life:

Full Load: 100,000 operations

Response Times:

Operate: 50ms

Release: 50ms

Load (Burden):

3VA

Temperature:

-28° to 65°C (-20° to 150°F)

Transient Protection:

10,000 volts for 20 microseconds

Mounting:

Uses an 8 pin octal socket. Requires a 600V-rated socket when used on system voltages greater than 300V (Macromatic Product Number 70169-D--see Page 81).

Indicator LED:

Red LED on when all conditions are normal, and off when a fault condition has occurred.

Reset:

Automatic upon correction of fault

Approvals:

DIMENSIONS

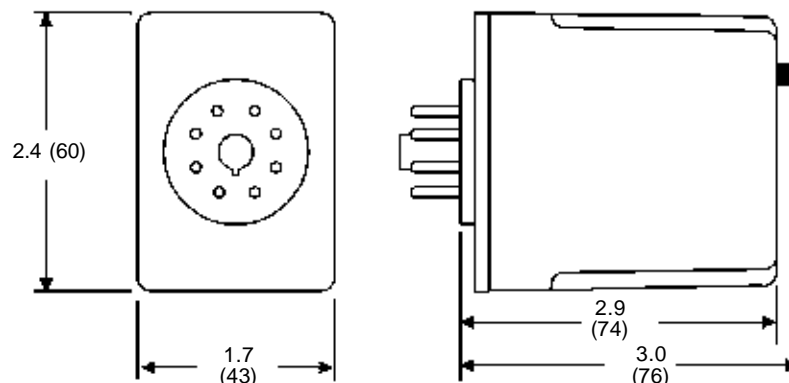

All Dimensions in
Inches (Millimeters)

PHASE MONITOR RELAYS

PHASE LOSS, PHASE REVERSAL & UNDERVOLTAGE PAP SERIES PLUG-IN



- ◆ Protects against phase loss, phase reversal & undervoltage
- ◆ Undervoltage setting is adjustable from 75-95% of nominal
- ◆ LED indicates both normal and fault conditions
- ◆ Compact plug-in case utilizing industry-standard 8 pin octal socket
- ◆ 10A SPDT output contacts



(with appropriate socket)

The PAP Series Phase Monitor Relays provide protection against phase loss, phase reversal & undervoltage in a compact plug-in design. These devices are designed to be compatible with most Wye or Delta systems. In Wye systems, a connection to a neutral is not required. Phase Monitor Relays protect against single phasing regardless of any regenerative voltages.

The relay is energized and the LED on when all three phase are present in the correct sequence at a voltage level above the undervoltage setting. The undervoltage drop-out can be set at 75-95% of operating voltage. Any fault will instantaneously de-energize the relay and turn off the LED. Re-energization is automatic upon correction of the fault condition.

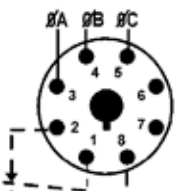
MOUNTING STYLE	NOMINAL VOLTAGE 50/60 Hz	UNDER-VOLTAGE RANGE	PRODUCT NUMBER	WIRING/SOCKET ■
Plug-in	120V	90-115V	PAP120	8 Pin Octal 70169-D  DIAGRAM 23
	208V	156-198V	PAP208	
	240V	180-230V	PAP240	
	400V	300-380V	PAP400 *	
	480V	360-460V	PAP480 *	

- * Requires a 600V-rated socket when used on system voltages greater than 300V.
- See Pages 81 & 82 for **Sockets & Accessories**.



800-238-7474

www.macromatic.com
sales@macromatic.com

PHASE MONITOR RELAYS

PHASE LOSS, PHASE REVERSAL & UNDERVOLTAGE

PAP SERIES PLUG-IN

APPLICATION DATA & DIMENSIONS

APPLICATION DATA

Phase Loss:

Unit trips on loss of any Phase A, B or C

Phase Reversal:

Unit trips if sequence of the three phases is anything other than A-B-C.

Undervoltage:

Adjustable over a range per product selection table. Unit trips when the average of all three lines is less than the adjusted set point.

Output Contacts:

10A Resistive SPDT @ 240V AC, 1/3HP @ 120/240V AC (N.O.), 1/6HP @ 120/240V AC (N.C.)

Life:

Full Load: 100,000 operations

Response Times:

Operate: 50ms

Release: 50ms

Load (Burden):

3VA

Temperature:

-28° to 65°C (-20° to 150°F)

Transient Protection:

10,000 volts for 20 microseconds

Mounting:

Uses an 8 pin octal socket. Requires a 600V-rated socket when used on system voltages greater than 300V (Macromatic Product Number 70169-D--see Page 81).

Indicator LED:

Red LED on when all conditions are normal, and off when a fault condition has occurred.

Reset:

Automatic upon correction of fault

Approvals:



with
appropriate
socket
File #E109466

DIMENSIONS

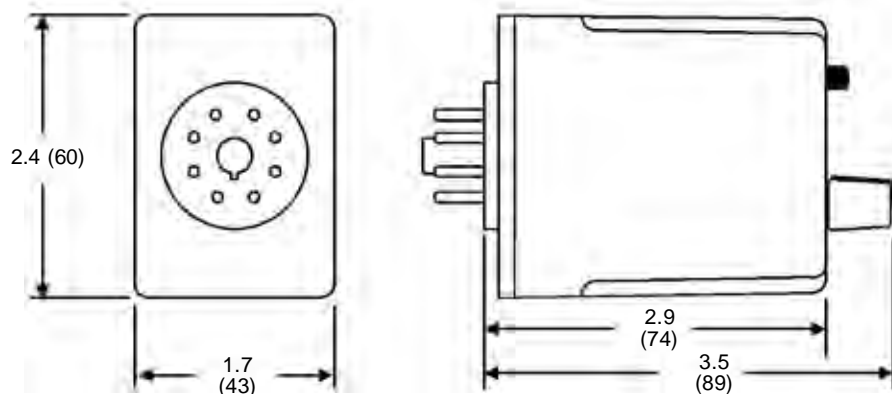

All Dimensions in
Inches (Millimeters)

PHASE MONITOR RELAYS

PHASE LOSS, PHASE REVERSAL, PHASE UNBALANCE, AND UNDER/OVER VOLTAGE PMP SERIES PLUG-IN



- ◆ Universal voltage range of 208-480V on PMPU provides the flexibility to cover a variety of applications with one unit
- ◆ Protects against phase loss, phase reversal, phase unbalance, undervoltage and overvoltage
- ◆ Variety of user-selectable and adjustable settings for the ultimate in three-phase protection
- ◆ Automatic or Manual Reset
- ◆ Multi-Color LED indicates normal condition and provides fault indication to simplify troubleshooting
- ◆ Compact plug-in case utilizing industry-standard 8 pin octal socket
- ◆ 10A SPDT output contacts



The PMP Series Phase Monitor Relays utilize a microprocessor-based design to provide protection against phase loss, phase reversal, phase unbalance, undervoltage and overvoltage. The PMPU is a universal voltage product that works on any three-phase system voltage from 208-480V (a separate 120V version is available). These devices are designed to be compatible with most Wye or Delta systems. In Wye systems, a connection to a neutral is not required. PMP Series products protect against unbalanced voltages or single phasing regardless of any regenerative voltages.

The relay is energized when the phase sequence and all voltages are correct. Any one of five fault conditions will de-energize the relay. As standard, re-energization is automatic upon correction of the fault condition. Manual reset is available if a momentary N.C. switch is wired to the appropriate terminals. A multi-color LED indicates normal condition and also provides specific fault indication to simplify troubleshooting.

The PMP Series offers a variety of user-adjustable settings. The percent phase unbalance is adjustable from 2-10%, and also has a "Disable" setting for those applications where poor voltage conditions could cause nuisance tripping. The undervoltage drop-out can be set at 80-95% of operating voltage (overvoltage setting is fixed at 110% of nominal). The adjustable time delay drop-out on undervoltage (0.1-20 seconds) eliminates nuisance tripping caused by momentary voltage fluctuations. There is also an adjustable time delay (1-300 seconds) on both power up and restart after a fault has been cleared.

MOUNTING STYLE	OPERATING VOLTAGE 50/60 Hz	PRODUCT NUMBER	WIRING/SOCKET ■
Plug-in	120V	PMP120	8 Pin Octal 70169-D DIAGRAM 104
	208-480V	PMPU *	

* Requires a 600V-rated socket when used on system voltages greater than 300V.

■ See Pages 81 & 82 for **Sockets & Accessories**.



800-238-7474

www.macromatic.com
sales@macromatic.com

PHASE MONITOR RELAYS

PHASE LOSS, PHASE REVERSAL, PHASE UNBALANCE, AND UNDER/OVER VOLTAGE

PMP SERIES PLUG-IN

APPLICATION DATA & DIMENSIONS

APPLICATION DATA

Phase Loss:

Unit trips on loss of any Phase A, B or C.

Phase Reversal:

Unit trips if rotation (sequence) of the three phases is anything other than A-B-C.

Undervoltage:

Adjustable from 80-95% of nominal voltage. Unit trips when the average of all three lines is less than the adjusted set point for a period longer than the adjustable time delay drop-out.

Overvoltage:

Fixed at 110% of nominal voltage. Unit trips when the average of all three lines is greater than the fixed set point for a period longer than the time delay drop-out.

Phase Unbalance:

Adjustable from 2 - 10% unbalance. Unit trips when any one of the three lines deviates from the average of all three lines by more than the adjusted set point. There is also a "Disable" setting adjustment that will turn off the Phase Unbalance Protection if nuisance tripping is a problem.

Output Contacts:

SPDT: 10A @ 240V AC/30V DC, 1/2HP @ 240V AC

Life:

Mechanical: 10,000,000 operations
Full Load: 100,000 operations

Response Times:

Power Up & Restart After Fault:	1 - 300 seconds adjustable
Drop-out Due to Fault:	
Phase Loss & Reversal	100ms fixed
Phase Unbalance	2 seconds fixed
Undervoltage	0.1 - 20 seconds adjustable
Overvoltage	Fixed Time Based on Inverse Time Curve

Hysteresis: 2 - 3%

Load (Burden): Less than 3VA

Temperature: -28° to 65°C (-20° to 150°F)

Mounting:

Uses an 8 pin octal socket. Requires a 600V-rated socket when used on system voltages greater than 300V (Macromatic Product Number 70169-D--see Page 81).

Indicator LED:

LED Status	Indicator
Green Steady	Normal / Relay ON
Green Flashing	Power Up / Restart Delay
Red Steady	Unbalance
Red Flashing	Undervoltage / Overvoltage
Amber Steady	Reversal
Amber Flashing	Loss
Green / Red Alternating	Undervoltage / Overvoltage Trip Pending
Red / Amber Alternating*	Nominal Voltage Set Error

* Applies to 208-480V units only.

Reset:

As standard, reset is automatic upon correction of fault. When a momentary-contact N.C. switch is wired across the Manual Reset terminals (6 & 7), the unit switches to manual reset mode and remote manual reset is available.

Approvals:



Low Voltage & EMC Directives
EN60947-1, EN60947-5-1

with appropriate socket
File #E109466

DIMENSIONS

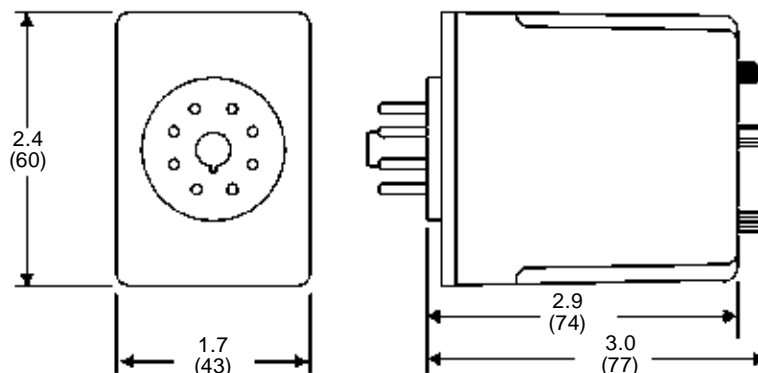

All Dimensions in Inches (Millimeters)

PHASE MONITOR RELAYS

PHASE LOSS, PHASE REVERSAL, PHASE UNBALANCE, AND UNDER/OVER VOLTAGE PMPU-FA SERIES PLUG-IN



- ◆ Universal voltage range of 208-480V (208 or 240V on 11 pin) provides the flexibility to cover a variety of applications with one unit
- ◆ Protects against phase loss, phase reversal, phase unbalance, undervoltage and overvoltage
- ◆ Choose between 11 Pin DPDT, 12 Pin DPDT, 8 Pin SPDT & 8 Pin SPDT/SPNO output configurations
- ◆ Automatic Reset
- ◆ Multi-Color LED indicates normal condition and provides fault indication to simplify troubleshooting
- ◆ Compact plug-in case utilizing industry-standard 8 or 11 pin octal or 12 pin square sockets

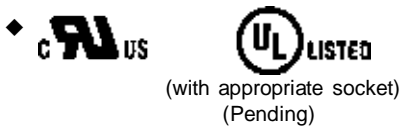

The PMPU-FA Series Phase Monitor Relays utilize a microprocessor-based design to provide protection against phase loss, phase reversal, phase unbalance, undervoltage and overvoltage, and are compatible with most Wye or Delta systems. They protect against unbalanced voltages or single phasing regardless of any regenerative voltages.

The relay is energized when the phase sequence and all voltages are correct. Any one of five fault conditions will de-energize the relay. Re-energization is automatic upon correction of the fault condition. A multi-color LED indicates normal condition and also provides specific fault indication to simplify troubleshooting.

These products offer a universal voltage design that works on any three-phase system voltage from 208-480V (208 or 240V only on the 11 pin DPDT version). The undervoltage drop-out is fixed at 90% & the overvoltage drop-out is fixed at 110% of operating voltage. The time delay drop-out on undervoltage is fixed at 4 seconds. The percent phase unbalance is fixed at 6%. The time delay on both power up and restart after a fault has been cleared is fixed at 2 seconds.

OUTPUT CONFIGURATION	OPERATING VOLTAGE 50/60 Hz	PRODUCT NUMBER *	WIRING/SOCKET ■
11 Pin DPDT	208V 240V	PMP208-FA11 PMP240-FA11	<p>11 Pin Octal 70170-D DIAGRAM 173</p>
12 Pin DPDT	208-480V	PMPU-FA12	<p>12 Pin 27390D DIAGRAM 174</p>
8 Pin SPDT	208-480V	PMPU-FA8	<p>8 Pin 70169-D DIAGRAM 23</p>
8 Pin SPDT/SPNO	208-480V	PMPU-FA8X	<p>8 Pin 70169-D DIAGRAM 175</p>

* Requires a 600V-rated socket when used on system voltages greater than 300V.

■ See Pages 81 & 82 for **Sockets & Accessories**.



800-238-7474

www.macromatic.com
sales@macromatic.com

PHASE MONITOR RELAYS

PHASE LOSS, PHASE REVERSAL, PHASE UNBALANCE, AND UNDER/OVER VOLTAGE

PMPU-FA SERIES PLUG-IN

APPLICATION DATA & DIMENSIONS

APPLICATION DATA

Phase Loss:

Unit trips on loss of any Phase A, B or C.

Phase Reversal:

Unit trips if rotation (sequence) of the three phases is anything other than A-B-C.

Undervoltage:

Fixed at 90% of nominal voltage. Unit trips when the average of all three lines is less than the adjusted set point for longer than the fixed 4 second time delay.

Overvoltage:

Fixed at 110% of nominal voltage. Unit trips when the average of all three lines is greater than the fixed set point for a period longer than the time delay drop-out.

Phase Unbalance:

Fixed at 6% unbalance. Unit trips when any one of the three lines deviates from the average of all three lines by more than the adjusted set point for longer than the fixed 2 second time delay.

Output Contacts:

10A @ 240V AC/30V DC,
1/2HP @ 120/240V AC (N.O.), 1/3HP @ 120/240V AC (N.C.)
B300 & R300; AC15 & DC13

Life:

Mechanical: 10,000,000 operations
Full Load: 100,000 operations

Response Times:

Power Up & Restart After Fault:	Fixed at 2 seconds
Drop-out Due to Fault:	
Phase Loss & Reversal	100ms fixed
Phase Unbalance	2 seconds fixed
Undervoltage	Fixed at 4 seconds
Overvoltage	Fixed Time Based on Inverse Time Curve

Hysteresis: 2 - 3%

Load (Burden): Less than 3VA

Temperature: -28° to 65°C (-20° to 150°F)

Mounting:

Use the appropriate socket as shown in the Product Selection Table on Page 14. Requires a 600V-rated socket when used on system voltages greater than 300V. See Pages 81 & 82 for Sockets & Accessories.

Indicator LED:

LED Status	Indicator
Green Steady	Normal / Relay ON
Green Flashing	Power Up / Restart Delay
Red Steady	Unbalance
Red Flashing	Undervoltage / Overvoltage
Amber Steady	Reversal
Amber Flashing	Loss
Green / Red Alternating	Undervoltage / Overvoltage Trip Pending
Red / Amber Alternating	Nominal Voltage Set Error

Reset:

Reset is automatic upon correction of fault.

Approvals:



DIMENSIONS

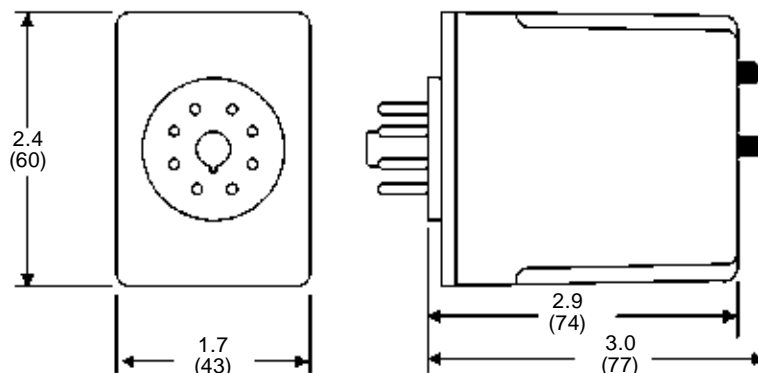

All Dimensions in Inches (Millimeters)

PHASE MONITOR RELAYS

PHASE LOSS, PHASE REVERSAL, PHASE UNBALANCE, AND UNDER/OVER VOLTAGE PMD SERIES SURFACE-MOUNT



- ◆ Universal voltage range of 208-480V on PMDU provides the flexibility to cover a variety of applications with one unit
- ◆ Protects against phase loss, phase reversal, phase unbalance, undervoltage and overvoltage
- ◆ Variety of user-selectable and adjustable settings for the ultimate in three-phase protection
- ◆ Automatic or Manual Reset
- ◆ Multi-Color LED indicates normal condition and provides fault indication to simplify troubleshooting
- ◆ 45mm DIN-style surface-mount case
- ◆ 10A SPDT & SPNC output contacts



The PMD Series Phase Monitor Relays utilize a microprocessor-based design to provide protection against phase loss, phase reversal, phase unbalance, undervoltage and overvoltage. The PMDU is a universal voltage product that works on any three-phase system voltage from 208-480V (separate 120V & 575V versions are available). These devices are designed to be compatible with most Wye or Delta systems. In Wye systems, a connection to a neutral is not required. PMD Series products protect against unbalanced voltages or single phasing regardless of any regenerative voltages.

The relay is energized when the phase sequence and all voltages are correct. Any one of five fault conditions will de-energize the relay. As standard, re-energization is automatic upon correction of the fault condition. Manual reset is available if a momentary N.C. switch is wired to the appropriate terminals. A multi-color LED indicates normal condition and also provides specific fault indication to simplify troubleshooting.

The PMD Series offers a variety of user-adjustable settings. The percent phase unbalance is adjustable from 2-10%, and also has a "Disable" setting for those applications where poor voltage conditions could cause nuisance tripping. The undervoltage drop-out can be set at 80-95% of operating voltage (overvoltage setting is fixed at 110% of nominal). The adjustable time delay drop-out on undervoltage (0.1-20 seconds) eliminates nuisance tripping caused by momentary voltage fluctuations. There is also an adjustable time delay (1-300 seconds) on both power up and restart after a fault has been cleared.

MOUNTING STYLE	OPERATING VOLTAGE 50/60 Hz	PRODUCT NUMBER ◆	WIRING ■
Surface-Mount	120V	PMD120	<p>DIAGRAM 105</p>
	208-480V	PMDU	
	575V	PMD600	

- ◆ To order PMD units with a second N.O. contact instead of the N.C. (terminals 21-22), add a suffix "-A1" to the Product Number, i.e., PMDU-A1. To order PMD units with DPDT output contacts instead of one SPDT and one SPNC, **but** with no manual reset feature, add a suffix "-A2" to the Product Number, i.e., PMDU-A2.
- See Page 82 for **Accessories**.



800-238-7474

www.macromatic.com
sales@macromatic.com

PHASE MONITOR RELAYS

PHASE LOSS, PHASE REVERSAL, PHASE UNBALANCE, AND UNDER/OVER VOLTAGE

PMD SERIES SURFACE-MOUNT

APPLICATION DATA & DIMENSIONS

APPLICATION DATA

Phase Loss:

Unit trips on loss of any Phase A, B or C.

Phase Reversal:

Unit trips if rotation (sequence) of the three phases is anything other than A-B-C.

Undervoltage:

Adjustable from 80-95% of nominal voltage. Unit trips when the average of all three lines is less than the adjusted set point for a period longer than the adjustable time delay drop-out.

Overvoltage:

Fixed at 110% of nominal voltage. Unit trips when the average of all three lines is greater than the fixed set point for a period longer than the time delay drop-out.

Phase Unbalance:

Adjustable from 2 - 10% unbalance. Unit trips when any one of the three lines deviates from the average of all three lines by more than the adjusted set point. There is also a "Disable" setting adjustment that will turn off the Phase Unbalance Protection if nuisance tripping is a problem.

Output Contacts:

10A SPDT & SPNC @ 240V AC/30VDC,
1/2HP @ 120/240V AC (N.O.), 1/3HP @ 120/240V AC (N.C.)

Life:

Mechanical: 10,000,000 operations
Full Load: 100,000 operations

Response Times:

Power Up & Restart After Fault: 1 - 300 seconds adjustable
Drop-out Due to Fault:

Phase Loss & Reversal	100ms fixed
Phase Unbalance	2 seconds fixed
Undervoltage	0.1 - 20 seconds adjustable
Overvoltage	Fixed Time Based on Inverse Time Curve

Hysteresis: 2 - 3%

Load (burden): Less than 3VA

Temperature: -28° to 65°C (-20° to 150°F)

Mounting:

Does not require a socket. Can either be mounted directly on 35mm DIN track with no additional parts or to a back-panel with two screws.

Indicator LED:

LED Status	Indicator
Green Steady	Normal / Relay ON
Green Flashing	Power Up / Restart Delay
Red Steady	Unbalance
Red Flashing	Undervoltage / Overvoltage
Amber Steady	Reversal
Amber Flashing	Loss
Green / Red Alternating	Undervoltage / Overvoltage Trip Pending
Red / Amber Alternating	Nominal Voltage Set Error

* Applies to 208-480V units only.

Reset:

As standard, reset is automatic upon correction of fault. When a momentary-contact N.C. switch is wired across the Manual Reset terminals (5 & 6), the unit switches to manual reset mode and remote manual reset is available.

Approvals:

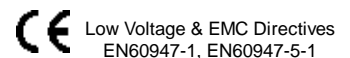

DIMENSIONS

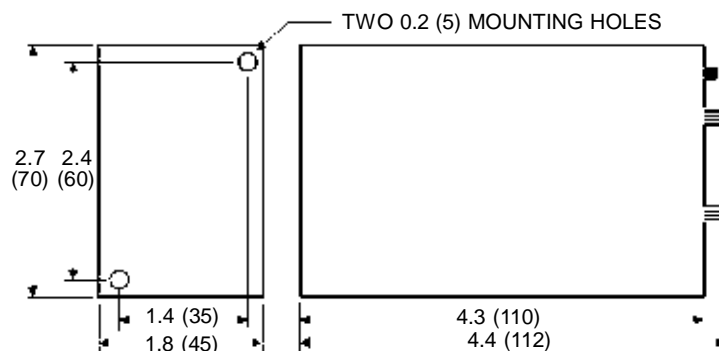

All Dimensions in Inches (Millimeters)

CURRENT MONITOR RELAYS

PRODUCT SUMMARY



Current Monitor Relays monitor AC single phase currents for over or under current conditions. A separate 24 or 120VAC input (supply) voltage is required to power these units. Three current ranges are available: 0.1 – 1A; 0.5 – 5A; and 1 – 10A. An external current transformer may be used to extend the range of these products (see Typical Installations on Page 19). All versions are available in a compact plug-in case utilizing industry-standard 8 or 11 pin octal sockets.

The Reference Guide below provides general information on the different versions of Current Monitor Relays offered by Macromatic (see Product Selection on the following pages for further details):

Series	Pick-up Current		Drop-Out Current		Function Chart	Page
	Setting	Time Delay	Setting	Time Delay		
CMP	Adjustable (Across Monitored Range)	Fixed 100ms *	Fixed at 95% of Pick-Up	Fixed 100ms *		20
CMKP			Adjustable 50- 95% of Pick-Up	Fixed 100ms *		20
COP	Adjustable (Across Monitored Range)	Adjustable 0.1-10 seconds	Fixed at 95% of Pick-Up	Fixed 100ms *		22
COKP			Adjustable 50- 95% of Pick-Up	Fixed 100ms *		22
CUP	Fixed (+5% of Drop-Out)	Fixed 100ms *	Adjustable (Across Monitored Range)	Adjustable 0.1-10 seconds		24

*Fixed time delay eliminates nuisance tripping due to short current surges or drops.

CURRENT MONITOR RELAYS

PRODUCT SUMMARY

Typical Installations

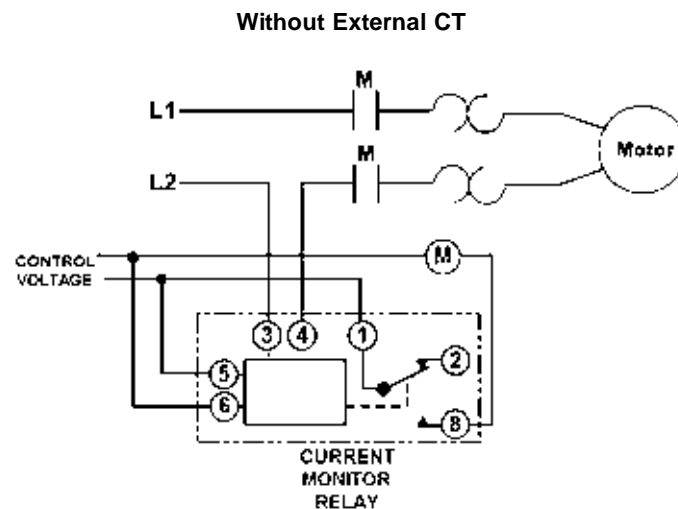
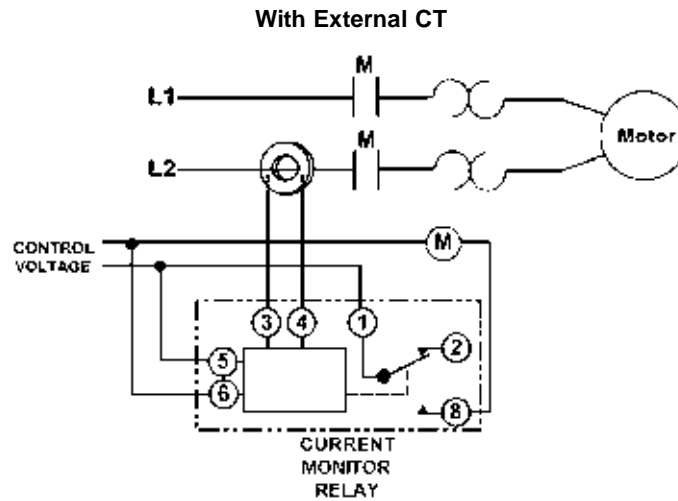

Approvals

All Macromatic plug-in Current Monitor Relays are UL Component Recognized. They are also UL Listed when used with the appropriate Macromatic socket.

CURRENT MONITOR RELAYS

CM SERIES STANDARD AC PLUG-IN



- ◆ Monitors AC single phase currents
- ◆ Three separate current monitoring ranges covering 0.1 - 10 amperes
- ◆ External CT can be used to extend ranges
- ◆ Adjustable Pick-up Setting with either Fixed or Adjustable Drop-out Setting
- ◆ LED indicates output relay status
- ◆ Choice of compact 8 Pin SPDT or 11 Pin DPDT plug-in case
- ◆ 10A output contacts



(with appropriate socket)

The CM Series is used to detect either an overcurrent or undercurrent condition. The pick-up current setting is user-adjustable within one of three ranges as shown in the Product Selection Table below. An external current transformer can be used to extend the range beyond 10 amperes.

Choose between a fixed drop-out current setting at 95% of the selected pick-up setting or an adjustable drop-out setting of 50-95% of the selected pick-up setting. The relay will energize when the monitored AC current is above the pick-up setting, and will de-energize when the monitored AC current is below the drop-out setting. The time delay on both pick-up and drop-out is fixed at 100ms (for products with adjustable time delay on pick-up, see page 22; for adjustable time delay on drop-out, see page 24).

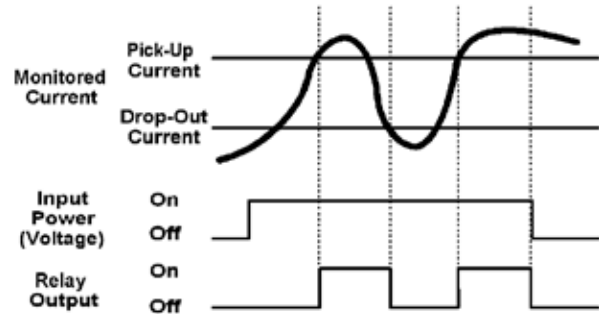

SPDT 8 Pin Plug-in

Pick-up Setting	Drop-Out Setting	Input Voltage	Current Range Monitored	Product Number	Wiring/Socket
Adjustable (Across Monitored Range)	Fixed (At 95% of Pick-Up)	24V AC	0.1 - 1A 0.5 - 5A 1 - 10A	CMP01A68 CMP05A68 CMP10A68	<p>Diagram 21</p>
		120V AC	0.1 - 1A 0.5 - 5A 1 - 10A	CMP01A62 CMP05A62 CMP10A62	
Adjustable (Across Monitored Range)	Adjustable (From 50-95% of Pick-Up)	24V AC	0.1 - 1A 0.5 - 5A 1 - 10A	CMKP01A68 CMKP05A68 CMKP10A68	
		120V AC	0.1 - 1A 0.5 - 5A 1 - 10A	CMKP01A62 CMKP05A62 CMKP10A62	

DPDT 11 Pin Plug-in

Pick-up Setting	Drop-Out Setting	Input Voltage	Current Range Monitored	Product Number	Wiring/Socket
Adjustable (Across Monitored Range)	Fixed (At 95% of Pick-Up)	24V AC	0.1 - 1A 0.5 - 5A 1 - 10A	CMP01A28 CMP05A28 CMP10A28	<p>Diagram 22</p>
		120V AC	0.1 - 1A 0.5 - 5A 1 - 10A	CMP01A22 CMP05A22 CMP10A22	
Adjustable (Across Monitored Range)	Adjustable (From 50-95% of Pick-Up)	24V AC	0.1 - 1A 0.5 - 5A 1 - 10A	CMKP01A28 CMKP05A28 CMKP10A28	
		120V AC	0.1 - 1A 0.5 - 5A 1 - 10A	CMKP01A22 CMKP05A22 CMKP10A22	



800-238-7474

www.macromatic.com
sales@macromatic.com

Sockets & Accessories—Pages 81 & 82

Application Data & Dimensions—Page 21

CURRENT MONITOR RELAYS

CM SERIES STANDARD

AC PLUG-IN

APPLICATION DATA & DIMENSIONS

APPLICATION DATA

Input Voltage Tolerance:

AC Operation: +10/-15% of nominal at 50/60 Hz.

Load (Burden):

Less than 5VA

Current Settings:

Pick-up: Adjustable throughout current range monitored
Drop-out: Fixed at 95% of pick-up setting (CMP Series); or
Adjustable from 50-95% of pick-up setting (CMKP Series)

Temperature:

-28° to 55° C (-20° to 131° F)

Response Times:

Pick-up: 100ms

Drop-out: 100ms

Output Contacts:

10A @ 240V AC/30V DC, 1/2HP @ 120/240V AC (N.O.),
1/3HP @ 120/240V AC (N.C.)

Life:

Mechanical: 10,000,000 operations

Full Load: 100,000 operations

Indicator LED: Green when Input Voltage is applied;
Red when Relay is energized

Reset: Automatic. Contact Macromatic for information on a product with a latching function--the relay remains energized even after the current drops below the drop-out setting until a remote N.C. button is opened.

Mounting:

Requires an 8 or 11 pin octal socket--see page 81.

Approvals:



Low Voltage & EMC Directives
EN60947-1, EN60947-5-1

with appropriate socket
File #E109466

DIMENSIONS

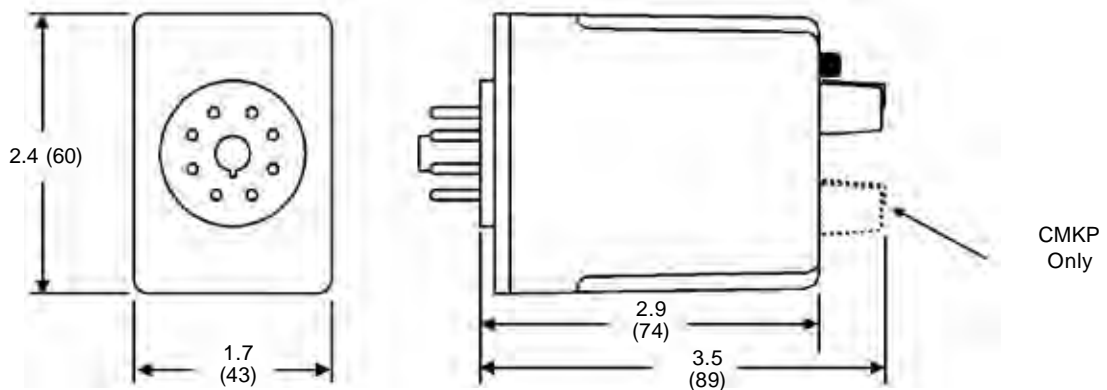

All dimensions are inches (millimeters)

CURRENT MONITOR RELAYS

CO SERIES OVERCURRENT AC PLUG-IN



- ◆ Monitors AC single phase currents for overcurrent conditions
- ◆ Three separate current monitoring ranges covering 0.1 - 10 amperes
- ◆ External CT can be used to extend ranges
- ◆ Adjustable Pick-up Setting with either Fixed or Adjustable Drop-out Setting
- ◆ Adjustable time delay of 0.1-10 seconds on pick-up
- ◆ LED indicates output relay status
- ◆ Choice of compact 8 Pin SPDT or 11 Pin DPDT plug-in case
- ◆ 10A output contacts



The CO Series is used to detect an overcurrent condition. The pick-up current setting is user-adjustable within one of three ranges as shown in the Product Selection Table below. An external current transformer can be used to extend the range beyond 10 amperes.

Choose between a fixed drop-out current setting at 95% of the selected pick-up setting or an adjustable drop-out setting of 50-95% of the selected pick-up setting. The relay will energize when the monitored AC current is above the pick-up setting for a period longer than the adjustable time delay of 0.1-10 seconds. This delay prevents nuisance tripping caused by inrush currents. It will de-energize when the monitored AC current is below the drop-out setting.

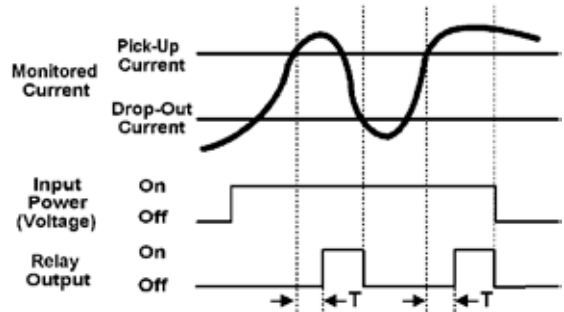

8 Pin SPDT Plug-in

Pick-up Setting	Drop-Out Setting	Input Voltage	Current Range Monitored	Product Number	Wiring/Socket
Adjustable (Across Monitored Range)	Fixed (At 95% of Pick-Up)	24V AC	0.1 - 1A 0.5 - 5A 1 - 10A	COP01A68 COP05A68 COP10A68	<p>Diagram 21</p>
		120V AC	0.1 - 1A 0.5 - 5A 1 - 10A	COP01A62 COP05A62 COP10A62	
		Adjustable (Across Monitored Range)	Adjustable (From 50-95% of Pick-Up)	24V AC	
		120V AC	0.1 - 1A 0.5 - 5A 1 - 10A	COKP01A62 COKP05A62 COKP10A62	

11 Pin DPDT Plug-in

Pick-up Setting	Drop-Out Setting	Input Voltage	Current Range Monitored	Product Number	Wiring/Socket
Adjustable (Across Monitored Range)	Fixed (At 95% of Pick-Up)	24V AC	0.1 - 1A 0.5 - 5A 1 - 10A	COP01A28 COP05A28 COP10A28	<p>Diagram 22</p>
		120VAC	0.1 - 1A 0.5 - 5A 1 - 10A	COP01A22 COP05A22 COP10A22	
		Adjustable (Across Monitored Range)	Adjustable (From 50-95% of Pick-Up)	24V AC	
		120V AC	0.1 - 1A 0.5 - 5A 1 - 10A	COKP01A22 COKP05A22 COKP10A22	



800-238-7474

www.macromatic.com
sales@macromatic.com

Sockets & Accessories—Pages 81 & 82

Application Data & Dimensions—Page 23

CURRENT MONITOR RELAYS

CO SERIES OVERCURRENT

AC PLUG-IN

APPLICATION DATA & DIMENSIONS

APPLICATION DATA

Input Voltage Tolerance:

AC Operation: +10/-15% of nominal at 50/60 Hz.

Load (Burden):

Less than 5VA

Current Settings:

Pick-up: Adjustable throughout current range monitored

Drop-out: Fixed at 95% of pick-up setting (COP Series); or
Adjustable from 50-95% of pick-up setting (COKP Series)

Temperature:

-28° to 55° C (-20° to 131° F)

Response Times:

Pick-up: Adjustable 0.1-10 seconds

Drop-out: Fixed 100ms

Output Contacts:

10A @ 240V AC/30V DC, 1/2HP @ 120/240V AC (N.O.),
1/3HP @ 120/240V AC (N.C.)

Life:

Mechanical: 10,000,000 operations

Full Load: 100,000 operations

Indicator LED: Green when Input Voltage is applied;
Red when Relay is energized

Reset: Automatic. Contact Macromatic for information on a product with a latching function--the relay remains energized even after the current drops below the drop-out setting until a remote N.C. button is opened.

Mounting:

Requires an 8 or 11 pin octal socket--see page 81.

Approvals:

UL US
File #E109466



Low Voltage & EMC Directives
EN60947-1, EN60947-5-1

UL LISTED
IND. CONT. EQUIP.
5017
with
appropriate
socket
File #E109466

DIMENSIONS

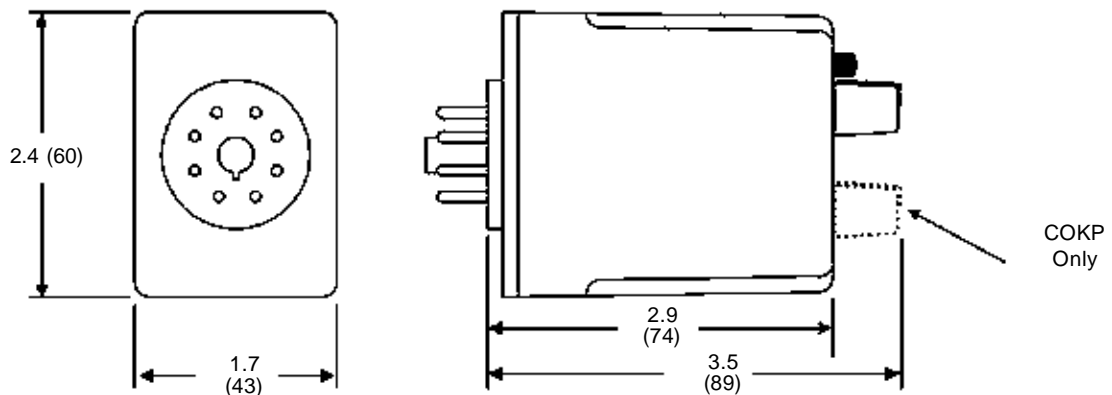

All dimensions are inches
(millimeters)

CURRENT MONITOR RELAYS

CU SERIES UNDERCURRENT AC PLUG-IN



- ◆ Monitors AC single phase currents for undercurrent conditions
- ◆ Three separate current monitoring ranges covering 0.1 - 10 amperes
- ◆ External CT can be used to extend ranges
- ◆ Adjustable Drop-out Setting with Fixed Pick-up Setting
- ◆ Adjustable time delay of 0.1-10 seconds on drop-out
- ◆ LED indicates output relay status
- ◆ Choice of compact 8 Pin SPDT or 11 Pin DPDT plug-in case

- ◆ 10A output contacts



(with appropriate socket)

The CU Series is used to detect an undercurrent condition. The drop-out current setting is user-adjustable within one of three ranges as shown in the Product Selection Table below. An external current transformer can be used to extend the range beyond 10 amperes.

The pick-up current setting is fixed at +5% of the selected drop-out setting. The relay will energize

when the monitored AC current is above the pick-up setting. It will de-energize when the monitored AC current is below the drop-out setting for a period longer than the adjustable time delay of 0.1-10 seconds. This delay prevents nuisance tripping caused by momentary line dips. The relay will energize when the current rises 5% above the drop-out setting.

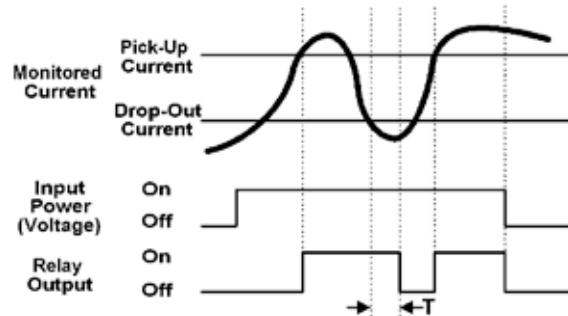

8 Pin SPDT Plug-in

Pick-up Setting	Drop-Out Setting	Input Voltage	Current Range Monitored	Product Number	Wiring/Socket
Fixed (At +5% of Drop-Out)	Adjustable (Across Monitored Range)	24V AC	0.1 - 1A 0.5 - 5A 1 - 10A	CUP01A68 CUP05A68 CUP10A68	<p>Diagram 21</p>
		120V AC	0.1 - 1A 0.5 - 5A 1 - 10A	CUP01A62 CUP05A62 CUP10A62	

11 Pin DPDT Plug-in

Pick-up Setting	Drop-Out Setting	Input Voltage	Current Range Monitored	Product Number	Wiring/Socket
Fixed (At +5% of Drop-Out)	Adjustable (Across Monitored Range)	24V AC	0.1 - 1A 0.5 - 5A 1 - 10A	CUP01A28 CUP05A28 CUP10A28	<p>Diagram 22</p>
		120V AC	0.1 - 1A 0.5 - 5A 1 - 10A	CUP01A22 CUP05A22 CUP10A22	



800-238-7474

www.macromatic.com
sales@macromatic.com

Sockets & Accessories—Pages 81 & 82

Application Data & Dimensions—Page 25

CURRENT MONITOR RELAYS

CU SERIES UNDERCURRENT

AC PLUG-IN

APPLICATION DATA & DIMENSIONS

APPLICATION DATA

Input Voltage Tolerance:

AC Operation: +10/-15% of nominal at 50/60 Hz.

Load (Burden):

Less than 5VA

Current Settings:

Pick-up: Fixed at 5% above adjustable drop-out setting

Drop-out: Adjustable throughout current range monitored

Temperature:

-28° to 55° C (-20° to 131° F)

Response Times:

Pick-up: Fixed 100ms

Drop-out: Adjustable 0.1-10 seconds

Output Contacts:

10A @ 240V AC/30V DC, 1/2HP @ 120/240V AC (N.O.),

1/3HP @ 120/240V AC (N.C.)

Life:

Mechanical: 10,000,000 operations

Full Load: 100,000 operations

Indicator LED: Green when Input Voltage is applied;
Red when Relay is energized

Reset: Automatic

Mounting:

Requires an 8 or 11 pin octal socket--see page 81.

Approvals:

Low Voltage & EMC Directives
EN60947-1, EN60947-5-1



with
appropriate
socket
File #E109466

DIMENSIONS

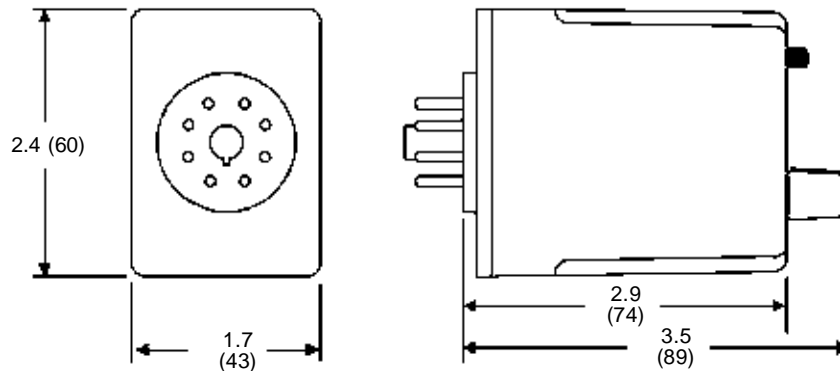

All dimensions are inches
(millimeters)

VOLTAGE MONITOR RELAYS

PRODUCT SUMMARY



Voltage Monitor Relays monitor either AC single phase (50-60Hz) or DC voltages to protect equipment against voltage fault conditions. No separate supply (input) voltage is required on any Macromatic Voltage Monitor Relays. All versions are available in a compact plug-in case utilizing an 8 pin octal socket or a 17.5mm IEC-style enclosure.

Macromatic offers two styles of Voltage Monitor Relays:

- ◆ **Over/Under Voltage Relays**--provides protection to equipment where either an over or under voltage condition is potentially damaging. When used as an under voltage relay, they provide protection to equipment that is required to operate above a minimum voltage. When used as over voltage relays, they protect equipment against excessive voltage conditions. Over/Under Voltage Relays are designed to operate when the operating voltage reaches a preset value and drop-out when the operating voltage drops to a level below the preset value.
- ◆ **Voltage Band Relays**--provides protection to equipment that is required to operate within an upper & lower voltage limit. As long as the operating voltage remains within an OVER & UNDER voltage range, the internal relay stays energized. If the operating voltage falls outside this range, the relay will drop-out.

These products are summarized below & on the next page:

Over/Undervoltage Relays

Plug-in 12-120V
17.5mm 24-240V

Series	Pick-out Voltage	Drop-Out Voltage	Time Delay Drop-Out	Function Chart	Page
VMP	Adjustable 85-115% of Nominal	Fixed at 95% of Pick-Up	Fixed 500ms *		28
VMKP	Adjustable 85-115% of Nominal	Adjustable 75-95% of Pick-Up	Fixed 500ms *		28
VAP	Adjustable 85-115% of Nominal	Fixed at 95% of Pick-Up	Adjustable 0.5-10 seconds		30
VAKP	Adjustable 85-115% of Nominal	Adjustable 75-95% of Pick-Up	Adjustable 0.5-10 seconds		30
VAKE	Adjustable 75-125% of Nominal	Adjustable 30-95% of Pick-Up	Adjustable 0.1-10 seconds		40

*Fixed time delay eliminates nuisance tripping due to short voltage surges or dips.

Plug-in 208-240V

Series	Pick-out Voltage	Drop-Out Voltage	Time Delay Pick-Up & Drop-Out	Function Chart	Page
VAKPU	Adjustable 85-115% of Nominal	Adjustable 80-95% of Pick-Up	Adjustable 0.0-10 seconds		34

*Fixed time delay eliminates nuisance tripping due to short voltage surges or dips.

VOLTAGE MONITOR RELAYS

PRODUCT SUMMARY

Voltage Band Relays

**Plug-in 12-120V
17.5mm 24-240V**

Series	Over Voltage Voltage	Under Voltage Voltage	Time Delay Drop-Out	Function Chart	Page
VWP	Adjustable 100-125% of Nominal	Adjustable 75-100% of Nominal	Fixed 500ms *	<p>The function chart shows a sinusoidal wave representing 'Monitored Voltage'. Two horizontal lines indicate 'Over Voltage' and 'Under Voltage' thresholds. The relay output is shown as a square wave that is 'On' when the voltage is within the band and 'Off' when it goes above or below. Time delays T1 and T2 are indicated for the pick-up and drop-out actions respectively.</p>	32
VWKP	Adjustable 100-125% of Nominal	Adjustable 75-100% of Nominal	Adjustable 0.5-10 seconds		32
VWKE	Adjustable 75-125% of Nominal	Adjustable 30-95% of Pick-Up Setting	Adjustable 0.1-10 seconds		41

*Fixed time delay eliminates nuisance tripping due to short voltage surges or dips.

Plug-in 208-240V

Series	Over Voltage Voltage	Under Voltage Voltage	Time Delay Pick-Up & Drop-Out	Function Chart	Page
VWKPU	Adjustable 100-125% of Nominal	Adjustable 75-100% of Nominal	Adjustable 0.1-10 seconds	<p>The function chart shows a sinusoidal wave representing 'Monitored Voltage'. Two horizontal lines indicate 'Over Voltage' and 'Under Voltage' thresholds. The relay output is shown as a square wave that is 'On' when the voltage is within the band and 'Off' when it goes above or below. Time delays T1 and T2 are indicated for the pick-up and drop-out actions respectively.</p>	36
VWKPU3 (3-Phase)	Adjustable 100-125% of Nominal	Adjustable 75-100% of Nominal	Adjustable 0.1-10 seconds		38

*Fixed time delay eliminates nuisance tripping due to short voltage surges or dips.

Approvals

All Macromatic plug-in Voltage Monitor Relays are UL Component Recognized. They are also UL Listed when used with the appropriate Macromatic socket.

All Macromatic 17.5mm Voltage Monitor Relays are UL Listed.

VOLTAGE MONITOR RELAYS

VM SERIES OVER/UNDERVOLTAGE

FIXED TIME DELAY ON DROP-OUT
12-120V PLUG-IN



- ◆ Monitors AC single phase and DC voltages
- ◆ Wide range of user-adjustable pick-up and drop-out settings
- ◆ Fixed time delay on drop-out of 500ms
- ◆ LED indicates output relay status
- ◆ Compact plug-in case utilizing industry standard 8 pin octal socket
- ◆ 10A DPDT output contacts



(with appropriate socket)

Over/Under Voltage Relays provide protection to equipment where either an over or under voltage condition is potentially damaging. They are designed to operate when the operating voltage reaches a preset value and drop-out when the operating voltage drops to a level below the preset value.

The pick-up voltage setting is user-adjustable from 85-115% of the nominal voltage rating. As standard, the VMP Series has a drop-out voltage setting fixed at 95% of the pick-up voltage setting. An adjustable drop-out setting of 75-95% of the pick-up setting is available on the VMKP Series. The relay energizes when the monitored voltage is above the pick-up setting. The relay de-energizes when the monitored voltage is below the drop-out setting for a period longer than the drop-out time delay (T), which is a fixed 500ms for VM Series products. An adjustable time delay on drop-out of 0.5-10 seconds is available (see Page 30).

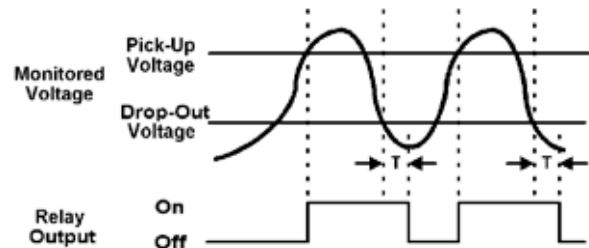

Adjustable Pick-Up, Fixed Drop-Out Settings * Time Delay on Drop-out Fixed at 500ms

NOMINAL VOLTAGE	PICK-UP VOLTAGE RANGE	DROP-OUT VOLTAGE RANGE*	PRODUCT NUMBER	WIRING/SOCKET
24V AC 120V AC	21-27V AC 102-138V AC	20-26V AC 97-131V AC	VMP024A VMP120A	8 Pin Octal 70169-D DIAGRAM 20
12V DC 24V DC 48V DC 110V DC	10-14V DC 21-27V DC 41-55V DC 94-126V DC	9-13V DC 20-26V DC 39-52V DC 89-121V DC	VMP012D VMP024D VMP048D VMP110D	

* Drop-out Voltage is fixed at 95% of the adjusted Pick-up Setting.

Adjustable Pick-Up & Drop-Out Settings ** Time Delay on Drop-out Fixed at 500ms

NOMINAL VOLTAGE	PICK-UP VOLTAGE RANGE	DROP-OUT VOLTAGE RANGE	PRODUCT NUMBER	WIRING/SOCKET
24V AC 120V AC	21-27V AC 102-138V AC	16-26V AC 77-131V AC	VMKP024A VMKP120A	8 Pin Octal 70169-D DIAGRAM 20
12V DC 24V DC 48V DC 110V DC	10-14V DC 21-27V DC 41-55V DC 94-126V DC	8-13V DC 16-26V DC 32-52V DC 71-121V DC	VMKP012D VMKP024D VMKP048D VMKP110D	

** Drop-out Voltage is adjustable from 75-95% of the adjusted Pick-up Setting.



800-238-7474

www.macromatic.com
sales@macromatic.com

Sockets & Accessories—Pages 81 & 82

Application Data & Dimensions—Page 29

VOLTAGE MONITOR RELAYS

VM SERIES OVER/UNDERVOLTAGE

FIXED TIME DELAY ON DROP-OUT

12-120V PLUG-IN

APPLICATION DATA & DIMENSIONS

OPERATING MODES

These relays can be used as either overvoltage or undervoltage relays, depending on the output contact used:

Overvoltage Relay

Provides protection to equipment that cannot handle excess voltages. Uses a normally closed contact (N.C.). As long as the monitored voltage remains below the maximum voltage the equipment can withstand (Pick-Up Setting), the relay remains de-energized and the N.C. contact remains closed, keeping the load energized. If the operating voltage increases beyond the maximum rating of the equipment, the relay energizes and the N.C. contact opens, turning off the load. When the voltage falls below the Drop-Out Setting (hysteresis), the relay de-energizes and the N.C. contact re-closes, turning on the load.

Undervoltage Relay

Provides protection to equipment that is required to operate above a certain minimum voltage. Uses a normally open contact (N.O.). As long as the monitored voltage is above the minimum value required (Pick-Up Setting), the relay will energize and the N.O. contact closes, turning on the load. If the voltage drops below the Drop-out Setting (the minimum voltage required minus the hysteresis), the relay will de-energize and the N.O. contact will re-open, turning off the load.

APPLICATION DATA

Voltage Tolerance:

+25%/-50% of nominal voltage; AC voltages are 50-60Hz;
No separate supply (input) voltage is required.

Load (Burden): Less than 3VA

Voltage Settings:

Pick-up: Adjustable from 85-115% of nominal voltage
Drop-out: Fixed at 95% of the pick-up setting

Temperature:

-28° to 55° C (-20° to 131° F)

Output Contacts:

10A @ 240V AC/30V DC, 1/2HP @ 120/240V AC (N.O.),
1/3HP @ 120/240V AC (N.C.)

Life:

Mechanical: 10,000,000 operations
Full Load: 100,000 operations

Response Times:

Operate: 500ms

Release: Fixed 500 ms

Indicator LED: Red Steady when Relay is energized; Green when Relay is Off.

Transient Protection:

10,000 volts for 20 microseconds

Reset: Automatic. Contact Macromatic for information on units with Manual Reset.

Approvals:



Low Voltage & EMC Directives
EN60947-1, EN60947-5-1



with appropriate socket
File #E109466

DIMENSIONS

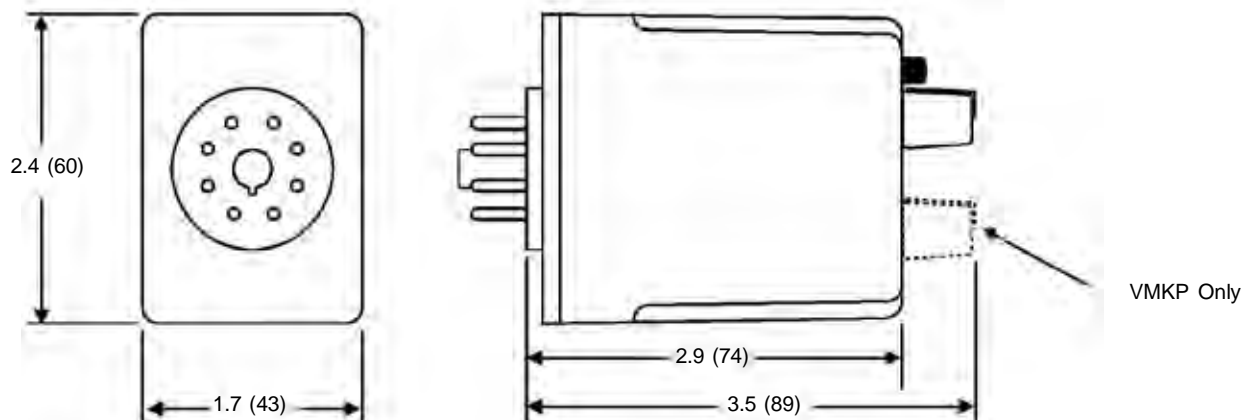

All Dimensions in
Inches (Millimeters)

VOLTAGE MONITOR RELAYS

VA SERIES OVER/UNDERVOLTAGE ADJUSTABLE TIME DELAY ON DROP-OUT 12-120V PLUG-IN



- ◆ Monitors AC single phase and DC voltages
- ◆ Wide range of user-adjustable pick-up and drop-out settings
- ◆ Adjustable time delay on drop-out of 0.5 - 10 seconds
- ◆ LED indicates output relay status
- ◆ Compact plug-in case utilizing industry standard 8 pin octal socket
- ◆ 10A DPDT output contacts



(with appropriate socket)

Over/Under Voltage Relays provide protection to equipment where an over or under voltage condition is potentially damaging. They are designed to operate when the operating voltage reaches a preset value and drop-out when the operating voltage drops to a level below the preset value.

The pick-up voltage setting is user-adjustable from 85-115% of the nominal voltage rating. As standard, the VAP Series has a drop-out voltage setting fixed at 95% of the pick-up voltage setting. An adjustable drop-out setting of 75-95% of the pick-up setting is available on the VAKP Series. The relay energizes when the monitored voltage is above the pick-up setting. The relay de-energizes when the monitored voltage is below the drop-out setting for a period longer than the drop-out time delay (T), which is adjustable from 0.5-10 seconds for VA Series products. A time delay on drop-out fixed at 500ms is available (see Page 28).

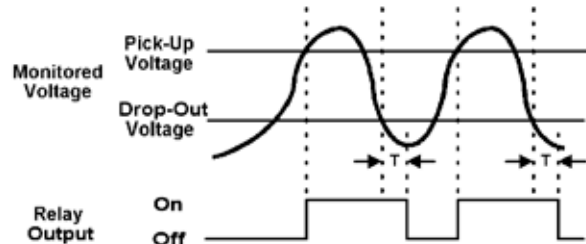

Adjustable Pick-Up, Fixed Drop-Out Settings * Adjustable Time Delay on Drop-out from 0.5 - 10 Seconds

NOMINAL VOLTAGE	PICK-UP VOLTAGE RANGE	DROP-OUT VOLTAGE RANGE*	PRODUCT NUMBER	WIRING/SOCKET
24V AC 120V AC	21-27V AC 102-138V AC	20-26V AC 97-131V AC	VAP024A VAP120A	<p>DIAGRAM 20</p>
12V DC 24V DC 48V DC 110V DC	10-14V DC 21-27V DC 41-55V DC 94-126V DC	9-13V DC 20-26V DC 39-53V DC 89-121V DC	VAP012D VAP024D VAP048D VAP110D	

* Drop-out Voltage is fixed at 95% of the adjusted Pick-up Setting.

Adjustable Pick-Up & Drop-Out Settings ** Adjustable Time Delay on Drop-out from 0.5 - 10 Seconds

NOMINAL VOLTAGE	PICK-UP VOLTAGE RANGE	DROP-OUT VOLTAGE RANGE	PRODUCT NUMBER	WIRING/SOCKET
24V AC 120V AC	21-27V AC 102-138V AC	16-26V AC 77-131V AC	VAKP024A VAKP120A	<p>DIAGRAM 20</p>
12V DC 24V DC 48V DC 110V DC	10-14V DC 21-27V DC 41-55V DC 94-126V DC	8-13V DC 16-26V DC 32-52V DC 71-121V DC	VAKP012D VAKP024D VAKP048D VAKP110D	

** Drop-out Voltage is adjustable from 75-95% of the adjusted Pick-up Setting.



800-238-7474

www.macromatic.com
sales@macromatic.com

VOLTAGE MONITOR RELAYS

VA SERIES OVER/UNDERVOLTAGE ADJUSTABLE TIME DELAY ON DROP-OUT 12-120V PLUG-IN APPLICATION DATA & DIMENSIONS

OPERATING MODES

These relays can be used as either overvoltage or undervoltage relays, depending on the output contact used:

Overvoltage Relay

Provides protection to equipment that cannot handle excess voltages. Uses a normally closed contact (N.C.). As long as the monitored voltage remains below the maximum voltage the equipment can withstand (Pick-Up Setting), the relay remains de-energized and the N.C. contact remains closed, keeping the load energized. If the operating voltage increases beyond the maximum rating of the equipment, the relay energizes and the N.C. contact opens, turning off the load. When the voltage falls below the Drop-Out Setting (hysteresis), the relay de-energizes and the N.C. contact re-closes, turning on the load.

Undervoltage Relay

Provides protection to equipment that is required to operate above a certain minimum voltage. Uses a normally open contact (N.O.). As long as the monitored voltage is above the minimum value required (Pick-Up Setting), the relay will energize and the N.O. contact closes, turning on the load. If the voltage drops below the Drop-out Setting (the minimum voltage required minus the hysteresis), the relay will de-energize and the N.O. contact will re-open, turning off the load.

APPLICATION DATA

Voltage Tolerance:

+25%/-50% of nominal voltage; AC voltages are 50-60Hz;
No separate supply (input) voltage is required.

Load (Burden): Less than 3VA

Voltage Settings:

Pick-up: Adjustable from 85-115% of nominal voltage
Drop-out: Adjustable from 75-95% of pick-up setting

Temperature:

-28° to 55° C (-20° to 131° F)

Output Contacts:

10A @ 240V AC/30V DC, 1/2HP @ 120/240V AC (N.O.),
1/3HP @ 120/240V AC (N.C.)

Life:

Mechanical: 10,000,000 operations
Full Load: 100,000 operations

Response Times:

Operate: 500ms

Release: Adjustable 0.5 - 10 Seconds

Indicator LED: Red Steady when Relay is energized; Green when Relay is Off.

Transient Protection:

10,000 volts for 20 microseconds

Reset: Automatic. Contact Macromatic for information on units with Manual Reset.

Approvals:



Low Voltage & EMC Directives
EN60947-1, EN60947-5-1



with
appropriate
socket

File #E109466

DIMENSIONS

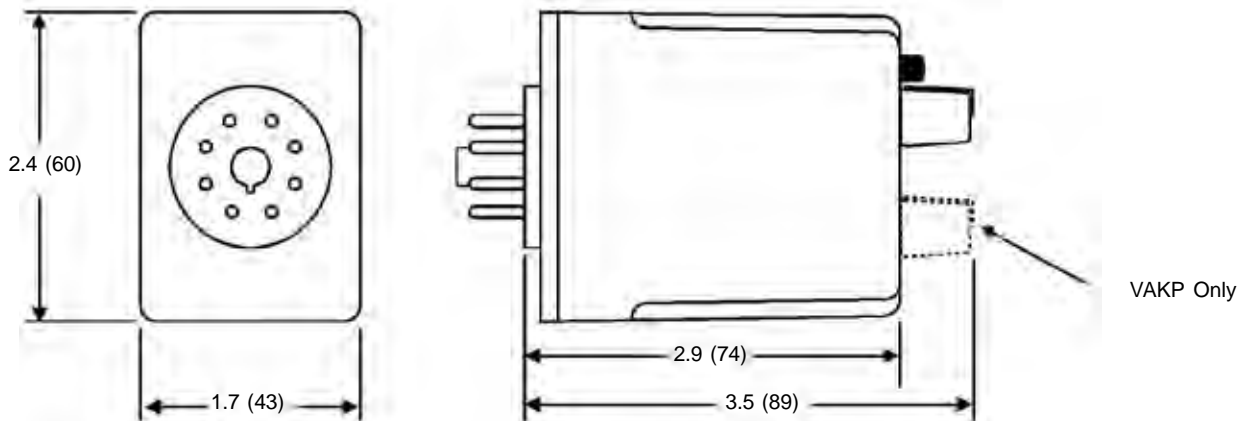

All Dimensions in
Inches (Millimeters)

VOLTAGE MONITOR RELAYS

VW SERIES VOLTAGE BAND

12-120V PLUG-IN



- ◆ Monitors AC single phase and DC voltages
- ◆ Provides voltage band (window) protection
- ◆ Wide range of user-adjustable Over Voltage and Under Voltage settings
- ◆ Fixed or adjustable time delay on drop-out
- ◆ LED indicates output relay status
- ◆ Compact plug-in case utilizing industry standard 8 pin octal socket
- ◆ 10A DPDT output contacts

- ◆ 10A DPDT output contacts



(with appropriate socket)

Voltage Band Relays provide protection to equipment that is required to operate within an upper & lower voltage limit. As long as the operating voltage remains within an OVER & UNDER voltage range, the internal relay stays energized. If the operating voltage falls outside this range, the relay will drop-out.

When nominal operating voltage with a value between the UPPER & LOWER setting is applied, the internal relay will energize (Pick-up). If the operating voltage falls outside the preset OVER trip point (adjustable 100-125% of nominal) or UNDER trip point (adjustable 75-100% of nominal) for a period longer than the drop-out time delay (T), the relay will de-energize (Drop-out). When the voltage returns to normal (within the preset OVER & UNDER trip points), the unit automatically resets and the relay energizes. Choose between a unit with fixed drop-out time of 500ms or one with an adjustable 0.5-10 second drop-out time.

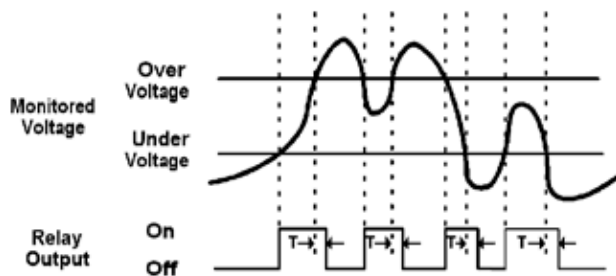

Fixed Drop-Out Time Delay (500ms)

NOMINAL VOLTAGE	OVER VOLTAGE RANGE	UNDER VOLTAGE RANGE	PRODUCT NUMBER	WIRING/SOCKET
24V AC 120V AC	24-30V AC 120-150V AC	18-24V AC 90-120V AC	VWP024A VWP120A	<p>DIAGRAM 20</p>
12V DC 24V DC 48V DC 110V DC	12-15V DC 24-30V DC 48-60V DC 110-137V DC	9-12V DC 18-24V DC 36-48V DC 83-110V DC	VWP012D VWP024D VWP048D VWP110D	

Adjustable Drop-Out Time Delay 0.5 - 10 Seconds

NOMINAL VOLTAGE	OVER VOLTAGE RANGE	UNDER VOLTAGE RANGE	PRODUCT NUMBER	WIRING/SOCKET
24V AC 120V AC	24-30V AC 120-150V AC	18-24V AC 90-120V AC	VWKP024A VWKP120A	<p>DIAGRAM 20</p>
12V DC 24V DC 48V DC 110V DC	12-15V DC 24-30V DC 48-60V DC 110-137V DC	9-12V DC 18-24V DC 36-48V DC 83-110V DC	VWKP012D VWKP024D VWKP048D VWKP110D	



800-238-7474

www.macromatic.com
sales@macromatic.com

Sockets & Accessories-Pages 81 & 82

Application Data & Dimensions-Page 33

VOLTAGE MONITOR RELAYS

VW SERIES VOLTAGE BAND

12-120V PLUG-IN

APPLICATION DATA & DIMENSIONS

APPLICATION DATA

Voltage Tolerance:

+25%/-50% of nominal voltage; AC voltages are 50-60Hz;
No separate supply (input) voltage is required.

Load (Burden): Less than 3VA

Voltage Settings:

Over Voltage: 100-125% of Nominal Voltage
Under Voltage: 75-100% of Nominal Voltage

Temperature:

-28° to 55° C (-20° to 131° F)

Indicator LED: Red Steady when Relay is energized; Green when Relay is Off.

Reset: Automatic. Contact Macromatic for information on units with Manual Reset.

Response Times:

Operate: 500ms

Release: Fixed 500 ms (VWP Series)
Adjustable 0.5 -10 Seconds (VWKP Series)

Output Contacts:

10A @ 240V AC/30V DC, 1/2HP @ 120/240V AC (N.O.),
1/3HP @ 120/240V AC (N.C.)

Life:

Mechanical: 10,000,000 operations
Full Load: 100,000 operations

Transient Protection:

10,000 volts for 20 microseconds

Approvals:

CALUS
File #E109466



Low Voltage & EMC Directives
EN60947-1, EN60947-5-1



with
appropriate
socket
File #E109466

DIMENSIONS

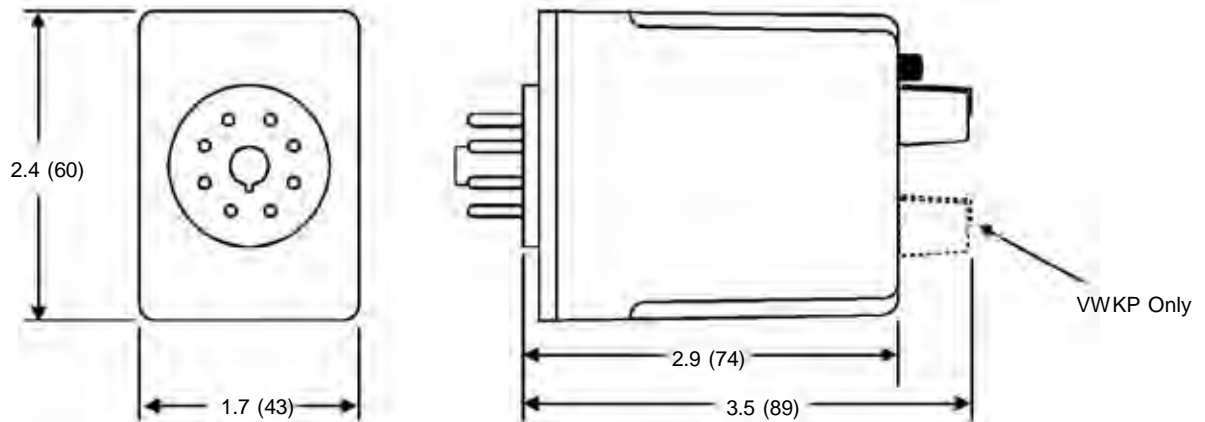

All Dimensions in
Inches (Millimeters)

VOLTAGE MONITOR RELAYS

VAKPU SERIES OVER/UNDERVOLTAGE

208-240V PLUG-IN



- ◆ Monitors 208-240V AC single phase voltage
- ◆ Provides over/under voltage protection
- ◆ Wide range of user-adjustable Pick-Up and Drop-Out settings
- ◆ Independently adjustable time delay on Pick-Up and Drop-Out
- ◆ LED indicates output relay status
- ◆ Compact plug-in case utilizing industry standard 8 pin octal socket
- ◆ 10A SPDT output contacts

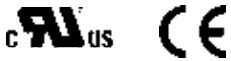

with appropriate socket

Over/Under Voltage Relays provide protection to equipment where an over or under voltage condition is potentially damaging. They are designed to operate when the operating voltage reaches a preset value and drop-out when the operating voltage drops to a level below the preset value.

The VAKPU can be used to monitor any 208, 220 or 240V AC single phase voltage. The pick-up voltage setting is user-adjustable from 85-115% of the nominal voltage setting. The drop-out setting is adjustable from 80-95% of the pick-up setting. The relay energizes when the monitored voltage is above the pick-up setting for a period longer than the adjustable pick-up time delay (T1) of 0.1-10 seconds. The relay de-energizes when the monitored voltage is below the drop-out setting for a period longer than the drop-out time delay (T2), which is adjustable from 0.1-10 seconds. The pick-up time (T1) and drop-out time (T2) are independently adjustable.

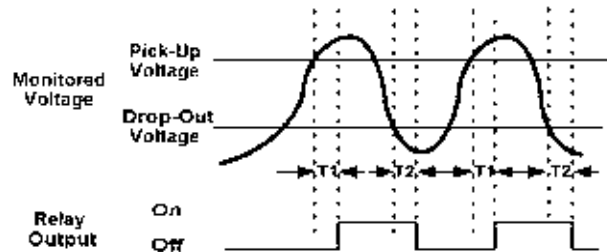

Adjustable Nominal Voltage Setting 208 to 240V AC Adjustable Time Delay on Pick-up & Drop-out from 0.1 - 10 Seconds

NOMINAL VOLTAGE	PICK-UP VOLTAGE RANGE	DROP-OUT VOLTAGE RANGE	PRODUCT NUMBER	WIRING/ SOCKET
208, 220 & 240V AC	85-115% of Nominal Voltage Setting	80-95% of Pick-Up Setting	VAKPU	8 PIN OCTAL 70169-D MONITORED VOLTAGE DIAGRAM 150



800-238-7474

www.macromatic.com
sales@macromatic.com

Sockets & Accessories-Pages 81 & 82

Application Data & Dimensions-Page 35

VOLTAGE MONITOR RELAYS

VAKPU SERIES OVER/UNDERVOLTAGE

208-240V PLUG-IN

APPLICATION DATA & DIMENSIONS

OPERATING MODES

These relays can be used as either overvoltage or undervoltage relays, depending on the output contact used:

Overvoltage Relay

Provides protection to equipment that cannot handle excess voltages. Uses a normally closed contact (N.C.). As long as the monitored voltage remains below the maximum voltage the equipment can withstand (Pick-Up Setting), the relay remains de-energized and the N.C. contact remains closed, keeping the load energized. If the operating voltage increases beyond the maximum rating of the equipment, the relay energizes and the N.C. contact opens, turning off the load. When the voltage falls below the Drop-Out Setting (hysteresis), the relay de-energizes and the N.C. contact re-closes, turning on the load.

Undervoltage Relay

Provides protection to equipment that is required to operate above a certain minimum voltage. Uses a normally open contact (N.O.). As long as the monitored voltage is above the minimum value required (Pick-Up Setting), the relay will energize and the N.O. contact closes, turning on the load. If the voltage drops below the Drop-out Setting (the minimum voltage required minus the hysteresis), the relay will de-energize and the N.O. contact will re-open, turning off the load.

APPLICATION DATA

Voltage Tolerance:

+50%/-40% of nominal voltage; AC voltages are 50-60Hz; No supply (input) voltage is required.

Load (Burden): Less than 3VA

Voltage Settings:

Pick-up: Adjustable from 85-115% of nominal voltage
Drop-out: Adjustable from 80-95% of pick-up setting

Temperature:

-28° to 65° C (-20° to 150° F)

Output Contacts:

SPDT: 10A @ 240V AC/30V DC, 1/2HP @ 240V AC

Life:

Mechanical: 10,000,000 operations
Full Load: 100,000 operations

Response Times:

Power Up: 2 seconds fixed delay
Operate: 0.1 - 10 seconds adjustable
Release: 0.1 - 10 seconds adjustable

Indicator LED: Red steady when relay is energized; Green steady when relay is off; and Green rapid flash when in power-up mode.

Reset: As standard, reset is automatic upon correction of a fault.

Approvals:



Low Voltage & EMC Directives
EN60947-1, EN60947-5-1

with
appropriate
socket
File #E109466

DIMENSIONS

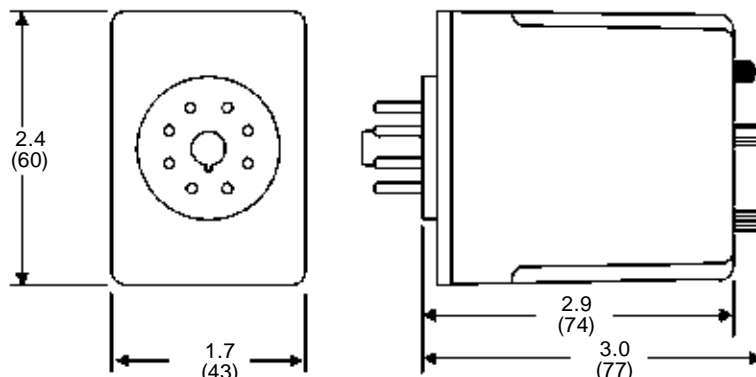

All Dimensions in
Inches (Millimeters)

VOLTAGE MONITOR RELAYS

VWKPU SERIES VOLTAGE BAND

208-240V PLUG-IN



- ◆ Monitors 208-240V AC single phase voltage
- ◆ Provides voltage band (window) protection
- ◆ Wide range of user-adjustable Over Voltage and Under Voltage settings
- ◆ Independently adjustable time delay on Pick-Up and Drop-Out
- ◆ LED indicates output relay status
- ◆ Compact plug-in case utilizing industry standard 8 pin octal socket
- ◆ 10A SPDT output contacts



with appropriate socket

Voltage Band Relays provide protection to equipment that is required to operate within an upper & lower voltage limit. As long as the operating voltage remains within an OVER & UNDER voltage range, the internal relay stays energized. If the operating voltage falls outside this range, the relay will drop-out.

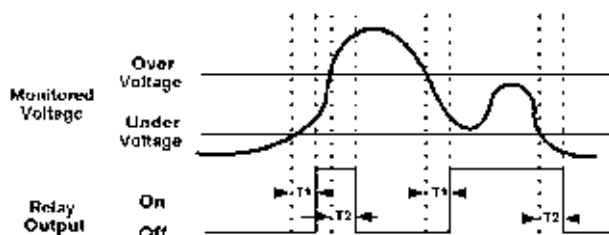

The VWKPU can be used to monitor any 208, 220 or 240V AC single phase voltage. The relay will

energize (pick-up) when the voltage falls within the preset OVER trip point (adjustable 100-125% of nominal) or UNDER trip point (adjustable 75-100% of nominal) for a period longer than the pick-up time delay (T1). If the operating voltage falls outside the preset OVER or UNDER trip points for a period longer than the drop-out time delay (T2), the relay will de-energize (drop-out). When the voltage returns to normal (within the preset OVER & UNDER trip points) for a period longer than the pick-up time delay (T1), the unit automatically resets and the relay energizes. The pick-up time (T1) and drop-out time (T2) are independently adjustable.

Adjustable Nominal Voltage Setting 208-240V AC Adjustable Time Delay on Pick-up & Drop-Out from 0.1 - 10 Seconds

NOMINAL VOLTAGE	UNDER VOLTAGE RANGE	OVER VOLTAGE RANGE	PRODUCT NUMBER	WIRING/SOCKET
208, 220 & 240V AC	75-100% of Nominal Voltage Setting	100-125% of Nominal Voltage Setting	VWKPU	8 PIN OCTAL 70169-D DIAGRAM 150



800-238-7474

www.macromatic.com
sales@macromatic.com

Sockets & Accessories-Pages 81 & 82

Application Data & Dimensions-Page 37

VOLTAGE MONITOR RELAYS

VWKPU SERIES VOLTAGE BAND

208-240V PLUG-IN

APPLICATION DATA & DIMENSIONS

APPLICATION DATA

Voltage Tolerance:

+50%/-40% of nominal voltage; AC voltages are 50-60Hz;
No supply (input) voltage is required.

Load (Burden): Less than 3VA

Voltage Settings:

Over Voltage: 100-125% of Normal Voltage

Under Voltage: 75-100% of Normal Voltage

Temperature:

-28° to 65° C (-20° to 150° F)

Output Contacts:

SPDT: 10A @ 240V AC/30V DC, 1/2HP @ 240V AC

Life:

Mechanical: 10,000,000 operations

Full Load: 100,000 operations

Response Times:

Power Up: 2 seconds fixed delay

Operate: 0.1 - 10 seconds adjustable

Release: 0.1 - 10 seconds adjustable

Indicator LED:

Red steady when relay is energized; Green when relay is off; Green rapid flashing when in power-up mode.

Reset: As standard, reset is automatic upon correction of a fault.

Approvals:



File #E109466



Low Voltage & EMC Directives
EN60947-1, EN60947-5-1



with appropriate socket
File #E109466

DIMENSIONS

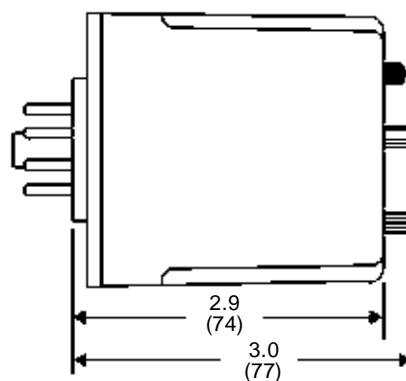
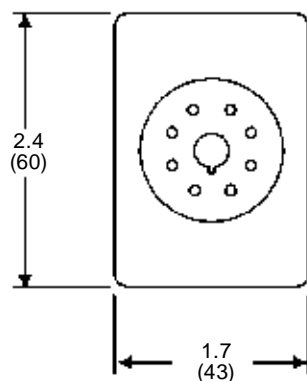

All Dimensions in Inches (Millimeters)

VOLTAGE MONITOR RELAYS

VWKPU3 SERIES THREE-PHASE VOLTAGE BAND

208-240V PLUG-IN

- ◆ Monitors 208-240V AC three phase voltage
- ◆ Provides voltage band (window) protection
- ◆ Wide range of user-adjustable Over Voltage and Under Voltage settings
- ◆ Independantly adjustable time delay on Pick-Up and Drop-Out
- ◆ LED indicates output relay status
- ◆ Compact plug-in case utilizing industry standard 8 pin octal socket
- ◆ 10A SPDT output contacts



with appropriate socket



Voltage Band Relays provide protection to equipment that is required to operate within an upper & lower voltage limit. As long as the operating voltage remains within an OVER & UNDER voltage range, the internal relay stays energized. If the operating voltage falls outside this range, the relay will drop-out.

The VWKPU3 can be used to monitor any 208-240V AC three phase voltage. The relay looks at the

average of the three phases and will energize (pick-up) when the average falls within the preset OVER trip point (adjustable 100-125% of nominal) or UNDER trip point (adjustable 75-100% of nominal) for a period longer than the pick-up time delay (T1). If the operating voltage falls outside the preset OVER or UNDER trip points for a period longer than the drop-out time delay (T2), the relay will de-energize (drop-out). When the voltage returns to normal (within the preset OVER & UNDER trip points) for a period longer than the pick-up time delay (T1), the unit automatically resets and the relay energizes. The pick-up time (T1) and drop-out time (T2) are independantly adjustable.

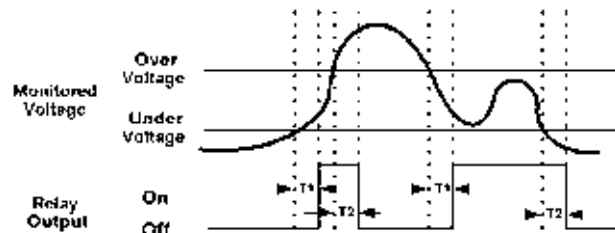

Adjustable Nominal Voltage Setting 208-240V AC Adjustable Time Delay on Pick-up & Drop-Out from 0.1 - 10 Seconds

NOMINAL VOLTAGE	UNDER VOLTAGE RANGE	OVER VOLTAGE RANGE	PRODUCT NUMBER	WIRING/SOCKET
208-240V AC	75-100% of Nominal Voltage Setting	100-125% of Nominal Voltage Setting	VWKPU3	8 PIN OCTAL 70169-D DIAGRAM 23



800-238-7474

www.macromatic.com
sales@macromatic.com

Sockets & Accessories-Pages 81 & 82

Application Data & Dimensions-Page 39

VOLTAGE MONITOR RELAYS

VWKPU3 SERIES THREE-PHASE VOLTAGE BAND

208-240V PLUG-IN

APPLICATION DATA & DIMENSIONS

APPLICATION DATA

Voltage Tolerance:

+50%/-40% of nominal voltage; AC voltages are 50-60Hz;
No supply (input) voltage is required.

Load (Burden): Less than 3VA

Voltage Settings:

Over Voltage: 100-125% of Nominal Voltage
Under Voltage: 75-100% of Nominal Voltage

Temperature:

-28° to 65° C (-20° to 150° F)

Output Contacts:

SPDT: 10A @ 240V AC/30V DC, 1/2HP @ 240V AC

Life:

Mechanical: 10,000,000 operations
Full Load: 100,000 operations

Response Times:

Operate: 0.1 - 10 seconds adjustable
Release: 0.1 - 10 seconds adjustable

Indicator LED: Red steady when relay is energized; Green when relay is off.

Reset: As standard, reset is automatic upon correction of a fault.

Approvals:



Low Voltage & EMC Directives
EN60947-1, EN60947-5-1

with appropriate socket
File #E109466

DIMENSIONS

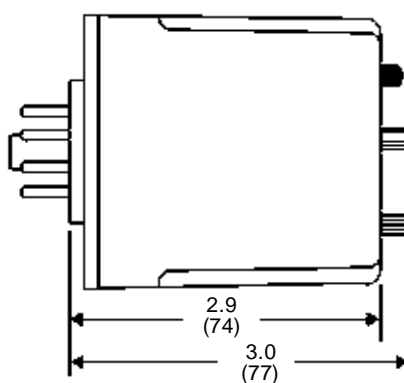
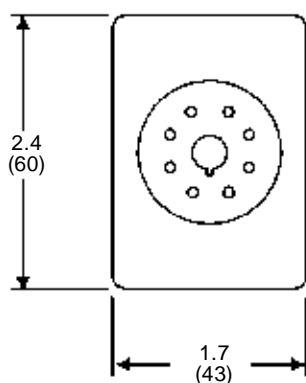

All Dimensions in Inches (Millimeters)

VOLTAGE MONITOR RELAYS

VAKE SERIES OVER/UNDERVOLTAGE 17.5MM MODULAR ENCLOSURE



- ◆ Monitors AC single phase and DC voltages
- ◆ Wide range of user-adjustable pick-up and drop-out settings
- ◆ Adjustable time delay on drop-out of 0.1- 10 seconds
- ◆ LED indicates nominal voltage & output relay status
- ◆ Compact 17.5mm enclosure mounts on 35mm DIN track
- ◆ 16A SPDT output contacts



Provides protection to equipment where an over or under AC single phase or DC voltage condition is potentially damaging. The relay energizes when the monitored voltage is above the pick-up setting & de-energizes when the monitored voltage is below the drop-out setting for a period longer than the adjustable drop-out time delay of 0.1-10 seconds. The adjustable time delay on drop-out is provided to prevent nuisance tripping. Both the pick-up & drop-out voltage settings are user-adjustable. The U_{max} dial sets the upper limit per the pick-up voltage range of the product. The U_{min} dial sets the lower limit at 30-95% of the pick-up setting.

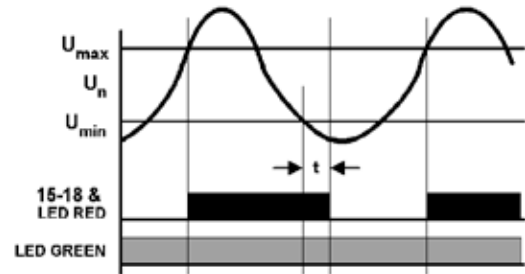

Catalog Number	VAKE024D	VAKE120A	VAKE240A
Nominal Voltage	24V DC	120V AC	240V AC
Pick-up Voltage Range	18-30V DC	80-150V AC	160-276V AC
Drop-out Voltage Range	30 - 95% of Pick-up Setting		
Consumption (Burden)	1.7W	3VA	3VA
Timing			
Time Delay on Pick-up	Fixed 100ms		
Time Delay on Drop-out	Adjustable 0.1-10 seconds		
Output			
Rating	16A @ 240V AC, 16A @ 24V DC 1HP @ 240V AC, 1/2HP @ 120V AC, B300		
Contact Material	Silver Alloy		
Life	30 million operations mechanical; 700,000 electrical		
Other			
Agency Approval	(File #E170213)		
Temperature	Operating: -20° to 55° C (-4° to 131° F)		
LED Indication	Green-Monitored Voltage Present Red-Blinking (Timing); Steady (Relay Energized)		
Terminations	14 AWG (2.1mm ²)		

CONNECTION DIAGRAM

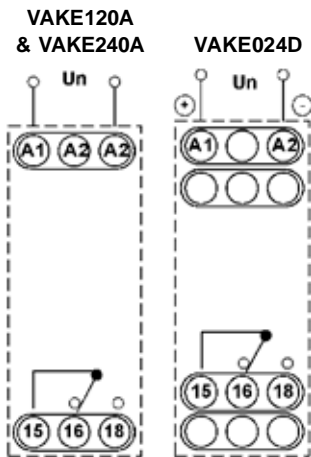

DIMENSIONS

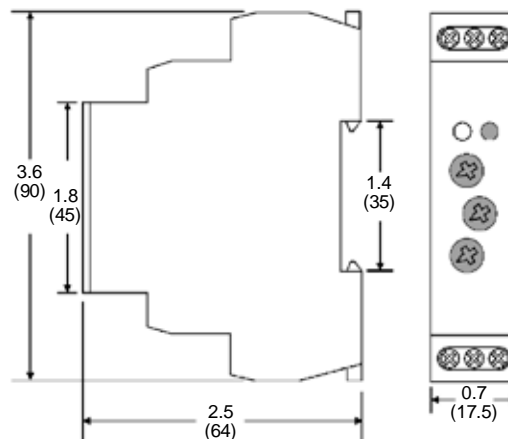

All Dimensions in Inches (Millimeters)



800-238-7474

www.macromatic.com
sales@macromatic.com

VOLTAGE MONITOR RELAYS

VWKE SERIES VOLTAGE BAND 17.5MM MODULAR ENCLOSURE



Provides protection to equipment that is required to operate within an upper & lower AC single phase or DC voltage limit. As long as the operating voltage remains within an OVER & UNDER voltage range, the internal relay stays energized. If the operating voltage falls outside this range, the relay will drop-out. The U_{max} dial sets the upper limit per the OVER voltage range of the product. The U_{min} dial sets the lower limit at 30-95% of the upper setting. This product has an adjustable time delay on drop-out of 0.1-10 seconds, which is provided to prevent nuisance tripping.

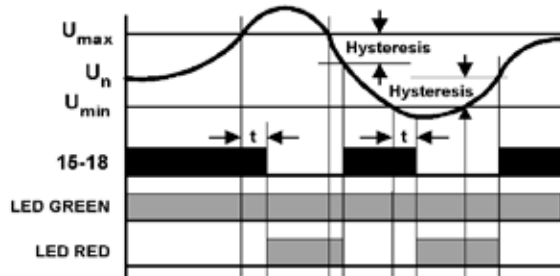

- ◆ Monitors AC single phase and DC voltages
- ◆ Provides voltage band (window) protection
- ◆ Wide range of user-adjustable Over Voltage and Under Voltage settings
- ◆ Adjustable time delay on drop-out of 0.1 - 10 seconds
- ◆ LED indicates nominal voltage & output relay status
- ◆ Compact 17.5mm enclosure mounts on 35mm DIN track
- ◆ 16A SPDT output contacts



Product Number	VWKE024D	VWKE120A	VWKE240A
Nominal Voltage	24V DC	120V AC	240V AC
OVER Voltage Range	18-30V DC	80-150V AC	160-276V AC
UNDER Voltage Range	30 - 95% of Pick-up Setting		
Consumption (Burden)	1.7W	3VA	3VA
Timing			
Time Delay on Pick-up	Fixed 100ms		
Time Delay on Drop-out	Adjustable 0.1-10 seconds		
Output			
Rating	16A @ 240V AC, 16A @ 24V DC 1HP @ 240V AC, 1/2HP @ 120V AC, B300		
Contact Material	Silver Alloy		
Life	30 million operations mechanical; 700,000 electrical		
Other			
Agency Approval	(File #E170213)		
Temperature	Operating: -20° to 55° C (-4° to 131° F)		
LED Indication	Green-Monitored Voltage Present Red-Blinking (Timing); Steady (Relay Energized)		
Terminations	14 AWG (2.1mm ²)		

CONNECTION DIAGRAM

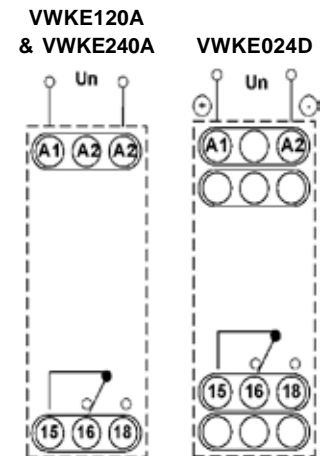

DIMENSIONS

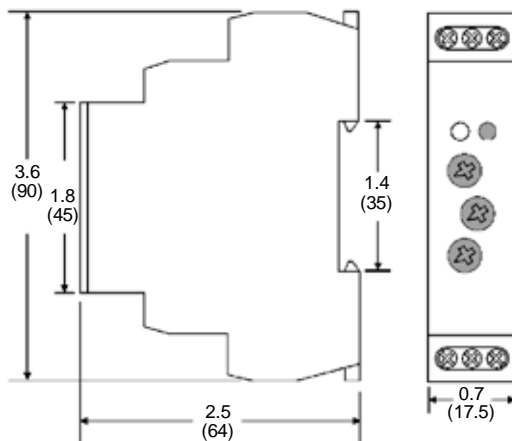

All Dimensions in Inches (Millimeters)



800-238-7474

www.macromatic.com
sales@macromatic.com

ALTERNATING RELAYS

SPDT & DPDT



- ◆ For duplex loads
- ◆ Can be used with one or two Control Switches
- ◆ Control voltages of 12, 24, 120 & 240V AC
- ◆ Compact plug-in design utilizing industry-standard 8 or 11 pin octal socket
- ◆ 10A SPDT or DPDT Output Configuration
- ◆ Optional low profile selector switch to lock in one sequence
- ◆ 2 LED's indicate load to energize next



with appropriate socket

Alternating Relays are used in special applications where the optimization of load usage is required by equalizing the run time of two loads. This alternating action is initiated by a control switch, such as a float switch, manual switch, timing relay, pressure switch, or other isolated contact. Each time the initiating switch is opened, the output relay contacts will change state, thus alternating the two loads. Two LED indicators show load to energize next.

The Alternating Relays listed on this page can be used with one or two control switches & are available in either SPDT or DPDT output configurations (see "Typical Installations" on Page 43 for more information). For products with DPDT Cross-Wired output configurations to be used with one, two or three control switches, see Page 44.

Each version is available with an optional three position selector switch. This allows the unit to alternate the two loads as normal, or lock the relay to one load or the other. By locking the Alternating Relay to one load, the other load can be removed for service without rewiring the first load for continuous operation. The selector switch has a low profile to prevent any accidental changes in status.

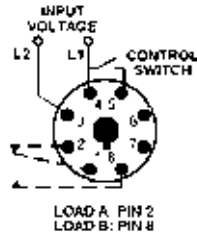
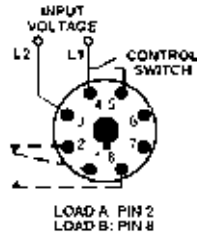
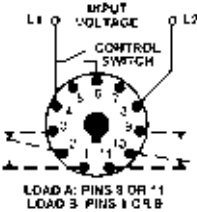
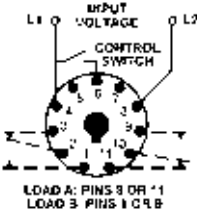
OUTPUT CONTACTS	CONTROL VOLTAGE	PRODUCT NUMBER	WIRING/SOCKET
SPDT w/o Selector Switch	12V AC 24V AC 120V AC 240V AC	ARP012A6 ARP024A6 ARP120A6 ARP240A6	8 Pin Octal 70169-D DIAGRAM 17 
SPDT w/ Selector Switch	12V AC 24V AC 120V AC 240V AC	ARP012A6R ARP024A6R ARP120A6R ARP240A6R	DIAGRAM 17 
DPDT w/o Selector Switch	12V AC 24V AC 120V AC 240V AC	ARP012A2 ARP024A2 ARP120A2 ARP240A2	11 Pin Octal 70170-D DIAGRAM 18 
DPDT w/ Selector Switch	12V AC 24V AC 120V AC 240V AC	ARP012A2R ARP024A2R ARP120A2R ARP240A2R	DIAGRAM 18 

■ See Pages 81 & 82 for **Sockets & Accessories**.



800-238-7474

www.macromatic.com
sales@macromatic.com

ALTERNATING RELAYS

SPDT & DPDT

APPLICATION DATA & DIMENSIONS

APPLICATION DATA

Voltage Tolerances: +10%/-15% of control voltage at 50/60Hz.

Load (Burden): Less than 3VA

Output Contacts:

10A @ 240V AC/30V DC,
1/2HP @ 120/240V AC (N.O.), 1/3HP @ 120/240VAC (N.C.)

Life:

Mechanical: 10,000,000 operations
Full Load: 100,000 operations

Temperature: -28° to 65°C (-20° to 150°F)

Transient Protection: 10,000 volts for 20 microseconds

Indicator LED's: 2 LED's marked LOAD A and LOAD B

Optional Selector Switch Settings:

LOCK LOAD A
ALTERNATE
LOCK LOAD B

Approvals:



File #E109466 File #LR45565

CE
Low Voltage &
EMC Directives
EN60947-1, EN60947-5-1



DIMENSIONS

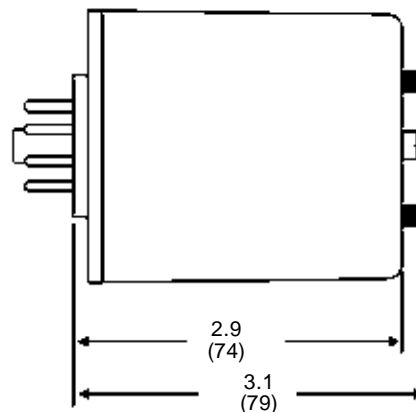
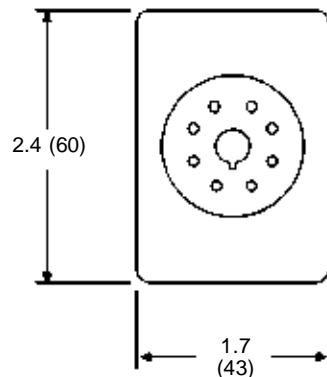

All Dimensions in Inches (Millimeters)

TYPICAL INSTALLATIONS

In the initial off state (Figure A), the Control Switch is open, the Alternating Relay is in the LOAD A position, and both loads (M1 & M2) are off. The red LED marked "LOAD A" is ON. When the Control Switch closes, it energizes Load M1. As long as the Control Switch remains closed, Load M1 remains energized. When the Control Switch opens, Load M1 is turned off and the Alternating Relay toggles to the LOAD B position. The red LED marked "LOAD B" glows. When the Control Switch closes again, it energizes Load M2. When the Control Switch opens, Load M2 is turned off, the Alternating Relay toggles back to the LOAD A position, and the process can be repeated again. On relays with DPDT contacts, two pilot lights can be used for remote indication of LOAD A or LOAD B status.

To eliminate any bounce condition of the Control Switch, the addition of a second switch (OFF) along with two auxiliary contacts is recommended as shown in Figure B.

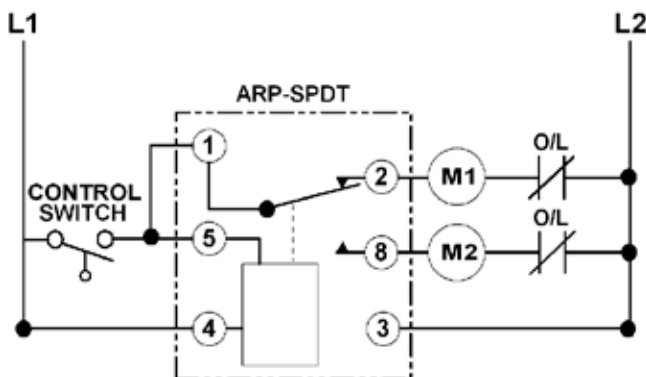

Figure A

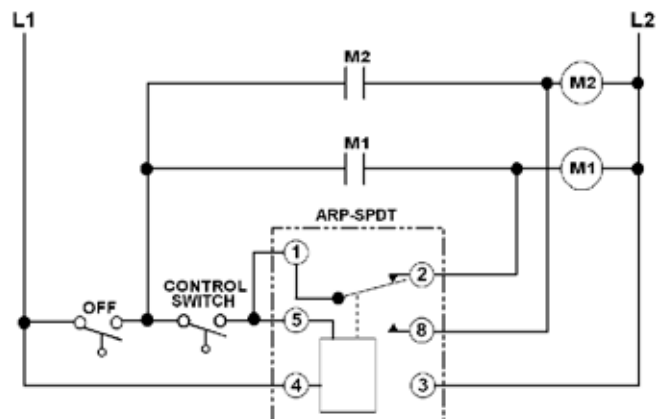

Figure B

ALTERNATING RELAYS

DPDT CROSS-WIRED



- ◆ For duplex loads
- ◆ 10A DPDT Cross-Wired Output Configuration when additional capacity is required
- ◆ Can be used with two or three Control Switches
- ◆ Control voltages of 12, 24, 120 & 240V AC
- ◆ Compact plug-in design utilizing industry-standard 8 pin octal socket
- ◆ Optional low profile selector switch to lock either load ON first
- ◆ 2 LED's indicate load to energize first



with appropriate socket



800-238-7474

www.macromatic.com
sales@macromatic.com

Alternating Relays with DPDT cross-wired outputs are used in applications requiring both (a) the optimization of load usage by equalizing the run time of two loads and (b) additional capacity in case of excess load requirements. This alternating action is initiated by a control switch, such as a float switch, manual switch, timing relay, pressure switch, or other isolated contact. Each time the initiating switch is opened, the output relay contacts will change state, thus alternating the two loads. Two LED indicators show the load to energize first.

Alternating Relays with DPDT cross-wired output configurations can be used with two or three control switches. See "Typical Installations" on Page 45 for more information. For products with SPDT or DPDT output configurations, see Page 42.

An optional three position selector switch is offered. This allows a DPDT cross-wired unit to alternate the two loads as normal, or lock the relay to always operate the same load first each time. In this manner, a load that has fewer hours of operation than the other load could be used more often in an effort to eventually balance the run time of both loads.

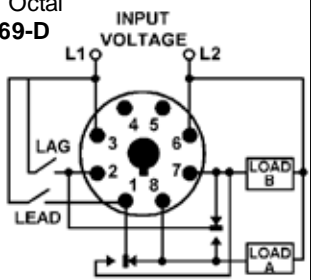
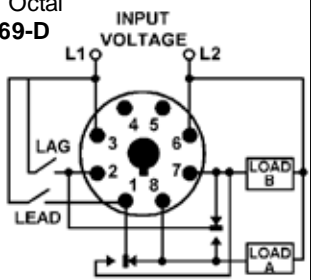
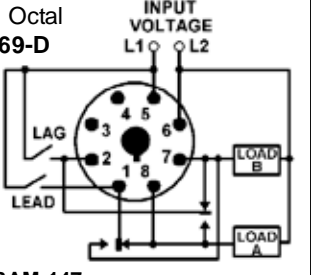
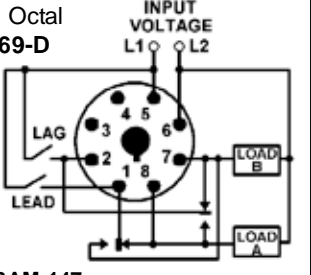
OUTPUT CONTACTS	CONTROL VOLTAGE	PRODUCT NUMBER	WIRING/SOCKET
DPDT CROSS-WIRED w/o Selector Switch	12V AC 24V AC 120V AC 240V AC	ARP012A3 ARP024A3 ARP120A3 ARP240A3	8 Pin Octal 70169-D 
DPDT CROSS-WIRED w/ Selector Switch	12V AC 24V AC 120V AC 240V AC	ARP012A3R ARP024A3R ARP120A3R ARP240A3R	
DPDT CROSS-WIRED w/o Selector Switch	12V AC 24V AC 120V AC 240V AC	ARP012A5 ARP024A5 ARP120A5 ARP240A5	8 Pin Octal 70169-D 
DPDT CROSS-WIRED w/ Selector Switch	12V AC 24V AC 120V AC 240V AC	ARP012A5R ARP024A5R ARP120A5R ARP240A5R	

■ See Pages 81 & 82 for **Sockets & Accessories**.

ALTERNATING RELAYS

DPDT CROSS-WIRED

APPLICATION DATA & DIMENSIONS

APPLICATION DATA

Voltage Tolerances: +10%/-15% of control voltage at 50/60Hz.

Load (Burden): Less than 3VA

Output Contacts:

10A @ 240V AC/30V DC,
1/2HP @ 120/240V AC (N.O.), 1/3HP @ 120/240VAC (N.C.)

Life:

Mechanical: 10,000,000 operations
Full Load: 100,000 operations

Temperature: -28° to 65°C (-20° to 150°F)

Transient Protection: 10,000 volts for 20 microseconds

Indicator LED's: 2 LED's, marked LOAD A and LOAD B

Optional Selector Switch Settings:

LOCK LOAD A (always energizes first)

ALTERNATE

LOCK LOAD B (always energizes first)

Approvals:



File #E109466



File #LR45565



Low Voltage &
EMC Directives
EN60947-1, EN60947-5-1



IND. CONT. EQUIP.
SUIT
with
appropriate
socket
File #E109466

DIMENSIONS

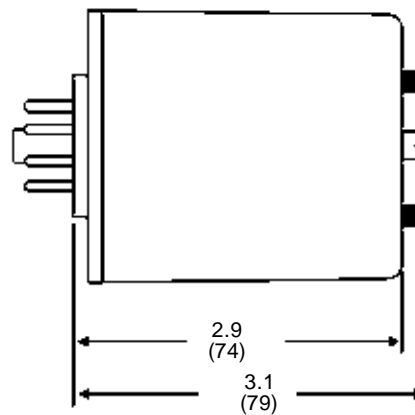
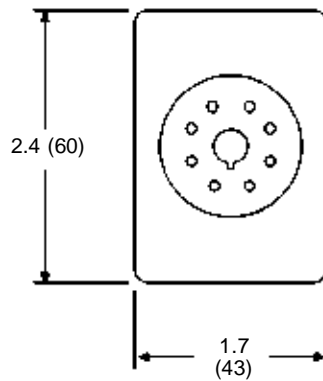

All Dimensions in
Inches (Millimeters)

TYPICAL INSTALLATIONS

In the initial off state (diagram below left), both the LEAD Control Switch and the LAG Control Switch are open, the Alternating Relay is in the LOAD A position, and both loads are off. The red LED marked "LOAD A" is ON. When the LEAD Control Switch closes, it energizes Load M1. As long as the LEAD Control Switch remains closed, Load M1 remains energized. If the LAG Control Switch closes, it energizes Load M2. When the LAG Control Switch opens, Load M2 is turned off. When the LEAD Control Switch opens, Load M1 is turned off and the Alternating Relay toggles to the LOAD B position. The red LED marked "LOAD B" is ON. When the LEAD Control Switch closes, it turns on Load M2. If the LAG Control Switch closes, it will energize Load M1. When the LAG Control Switch opens, Load M1 is turned off. When the LEAD Control Switch opens, Load M2 is turned off, the Alternating Relay toggles back to the LOAD A position, and the process can be repeated again.

The diagram below right illustrates a type of operation known as "Sequence On - Simultaneously Off (S.O.S.O.)"-the two loads are energized sequentially, but remain on together until the OFF switch is opened.

In the initial OFF state, all three switches are open, the Alternating Relay is in the LOAD A position, and both loads are off. No action happens with the Alternating Relay or either load when the OFF Switch closes. When the LEAD Switch closes, Load M1 turns on. When the LAG Switch closes, Load M2 turns on. Both loads remain on as long as all three switches are closed.

When the LAG Switch opens, Load M2 remains on because the OFF Switch is still closed. When the LEAD Switch opens, Load M1 remains on because the STOP Switch is still closed. When the OFF Switch opens, both Load M1 and Load M2 are turned off simultaneously. The Alternating Relay toggles to the LOAD B position. The entire cycle is then repeated, but with Load M2 energized first followed by Load M1.

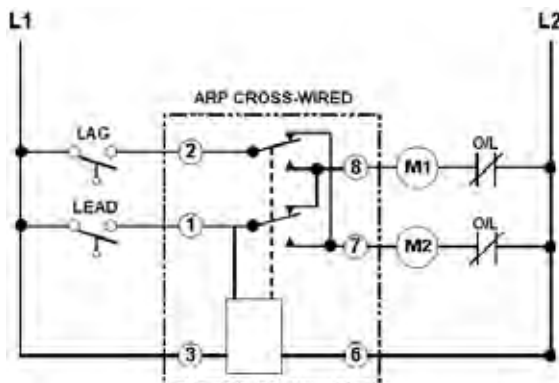

Figure A

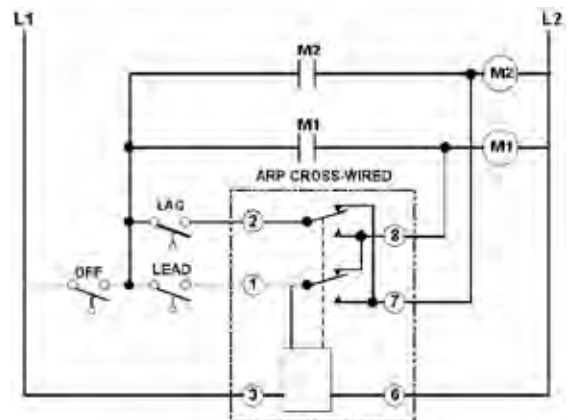

Figure B

PUMP SEAL FAILURE RELAYS

PLUG-IN SINGLE & DUAL CHANNEL



- ◆ Monitors Submersible Pump Seals for Leakage
- ◆ Single or Dual Channel for Monitoring 1 or 2 Pumps
- ◆ Three Adjustable Sensitivity Ranges
- ◆ Optional Fixed Sensitivity Setting Available
- ◆ Optional Low-Profile Adjustment Knob
- ◆ Uses industry-standard 8 & 11 pin octal sockets



with appropriate socket

SFP Series Pump Seal Failure Relays are designed to monitor the shaft seals of submersible pumps. A resistive-measuring probe is installed in the pump seal cavity. If the seal starts to leak, contaminating fluid enters the seal cavity, lowering the resistance between the internal probe & the common connection. When the resistance drops below the user-adjustable sensitivity set-point of the relay, the output relay energizes & the LED turns ON. The relay output can be used to give an alarm indication of a leaking seal. These products will automatically reset when the fault condition clears.

Three output configurations are offered: an 8 pin SPDT single channel relay & an 11 pin DPDT single channel relay to monitor a single pump, and an 8 pin dual channel relay (with 2 SPNO contacts) to monitor two pumps. In addition to the three adjustable sensitivity ranges offered, relays with fixed values are available--contact Macromatic for more information (minimum quantities apply). An optional low-profile adjustment knob to prevent accidental change of setting is also available (see footnote below).

CONFIGURATION	INPUT VOLTAGE	SENSITIVITY RANGE	PRODUCT NUMBER ◆	WIRING/SOCKET ■
SINGLE CHANNEL 8 Pin SPDT	120V AC	10K to 25KΩ 4.7K to 100KΩ 10K to 250KΩ	SFP120A025 SFP120A100 SFP120A250	8 Pin Octal 70169-D DIAGRAM 163
	240V AC	10K to 25KΩ 4.7K to 100KΩ 10K to 250KΩ	SFP240A025 SFP240A100 SFP240A250	
SINGLE CHANNEL 11 Pin DPDT	120V AC	10K to 25KΩ 4.7K to 100KΩ 10K to 250KΩ	SFP120B025 SFP120B100 SFP120B250	11 Pin Octal 70170-D DIAGRAM 162
	240V AC	10K to 25KΩ 4.7K to 100KΩ 10K to 250KΩ	SFP240B025 SFP240B100 SFP240B250	
DUAL CHANNEL 8 Pin (2) SPNO	120V AC	10K to 25KΩ 4.7K to 100KΩ 10K to 250KΩ	SFP120C025 SFP120C100 SFP120C250	8 Pin Octal 70169-D DIAGRAM 164
	240V AC	10K to 25KΩ 4.7K to 100KΩ 10K to 250KΩ	SFP240C025 SFP240C100 SFP240C250	

◆ To order a product with a low-profile adjustment knob, add the suffix "L" to the Product Number, i.e., SFP120A100L.

■ See Pages 81 & 82 for **Sockets & Accessories**.



800-238-7474

www.macromatic.com
sales@macromatic.com

PUMP SEAL FAILURE RELAYS

PLUG-IN

SINGLE & DUAL CHANNEL
APPLICATION DATA & DIMENSIONS

TYPICAL INSTALLATIONS

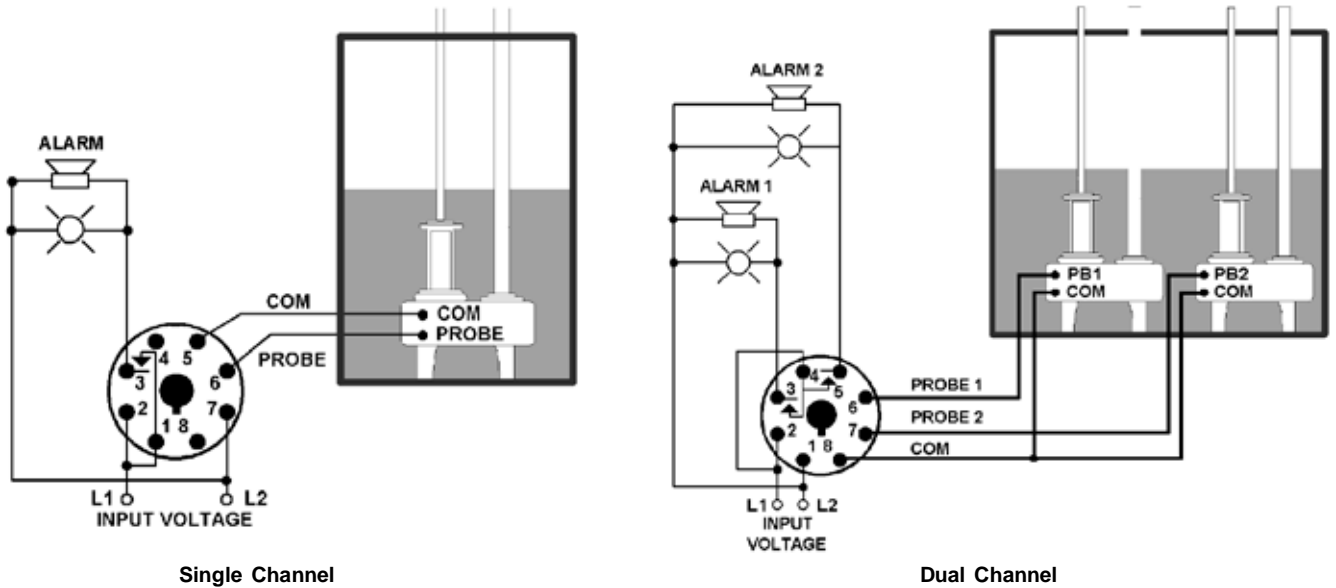

APPLICATION DATA

Voltage Tolerance:

AC Operation: +10/-15% of nominal at 50/60 Hz.

Load (Burden):

2 VA

Probe Voltage:

9V DC

Response Time:

Pick-up: 10ms

Drop-out: 10ms

LED Indicator:

Red ON when seal leak detected & relay energized.

Temperature:

-28° to 65°C (-18° to 150°F)

Output Contacts:

Single Channel Relays: 10A @ 240V AC / 7A @ 30V DC,
1/4HP @ 120/240V AC

Dual Channel Relays: (2) 5A @ 240V AC / 5A @ 30V DC,
1/4HP @ 120/240V AC

Life:

Mechanical: 10,000,000 operations

Full Load: 100,000 operations

Insulation Voltage:

2,000 volts

Approvals:

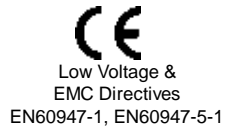

DIMENSIONS

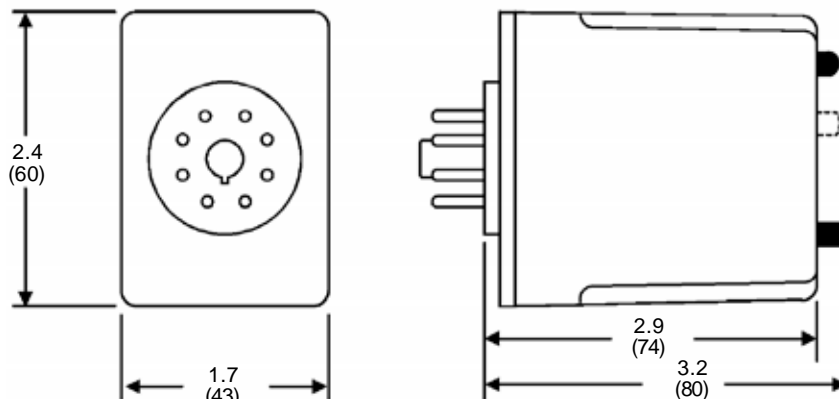

All Dimensions in
Inches (Millimeters)

INTRINSICALLY-SAFE RELAYS

ISP SERIES PLUG-IN SINGLE CHANNEL



- ◆ Provides Low Cost Alternative to Explosion-Proof Enclosures
- ◆ Single Channel
- ◆ Isolated 10A SPNO output contact
- ◆ 24 or 120V AC Input Voltage
- ◆ LED Status Indicator



UL File No.
E318075

UL913

The ISP series of Intrinsically Safe Relays provide a safe and reliable method to control a load (motor starter, relay, etc.) with an input device (switch, sensor, etc.) located in a hazardous area. The Instrument Society of America defines intrinsically safe equipment & wiring in their specification ISA-RP12.2 as: “equipment and wiring which is incapable of releasing sufficient electrical or thermal energy under normal or abnormal conditions to cause ignition of a specific hazardous atmospheric mixture in its most ignited concentration. Intrinsically safe terminations and wiring may be brought into any hazardous location of any Group classification for which it is accepted without requiring explosion-proof housing or other means of protection”.

UL Listed apparatus provides intrinsically safe circuits for use in Class I Groups A, B, C, D, Class II Groups E, F, G, and Class III Hazardous Locations. The ISP relay must be mounted in a non-hazardous area, following Macromatic Control Drawing Number ISR2A01D. In order to comply with UL requirements, intrinsically safe and non-intrinsically safe wiring must be physically separated to prevent inadvertent bypass.

Each ISP relay consists of an intrinsically safe control switch input and an electro-mechanical relay output. When the control switch in the hazardous area is closed, the relay is energized. When the control switch is opened, the relay is de-energized.

Typical applications include pump lift stations, grain elevators, refineries and paint rooms.

INPUT VOLTAGE 50/60Hz.	NUMBER OF CHANNELS	PRODUCT NUMBER	WIRING/ SOCKETS ■
120V AC	Single	ISP120A	<p>DIAGRAM 160</p>
24V AC	Single	ISP024A	

■ Both an integral spring mating clip and the appropriate 8 pin socket are included with the plug-in relay.



800-238-7474

www.macromatic.com
sales@macromatic.com

INTRINSICALLY-SAFE RELAYS

ISP SERIES PLUG-IN

SINGLE CHANNEL

APPLICATION DATA & DIMENSIONS

APPLICATION DATA

Input Voltage:

24 or 120V AC, $\pm 10\%$, 50/60Hz

Load (Burden):

1.25 VA

Output Contacts:

SPNO 10A @ 120V AC Resistive

Life:

Mechanical: 10,000,000 operations

Full Load: 100,000 operations

Response Times:

Operate: 11 ms

Release: 4 ms

Temperature:

Operate: -20° to 60°C (-4° to 140°F)

Storage: -45° to 85°C (-49° to 185°F)

Insulation Voltage:

2,000 volts

LED Indicator:

Green ON when relay is energized & OFF when relay is de-energized.

Mounting:

Both an integral spring mating clip and the appropriate 8 pin socket are included with the plug-in relay.

Approvals:

File #E318075

UL913

UL Control Drawing ISR2A01D

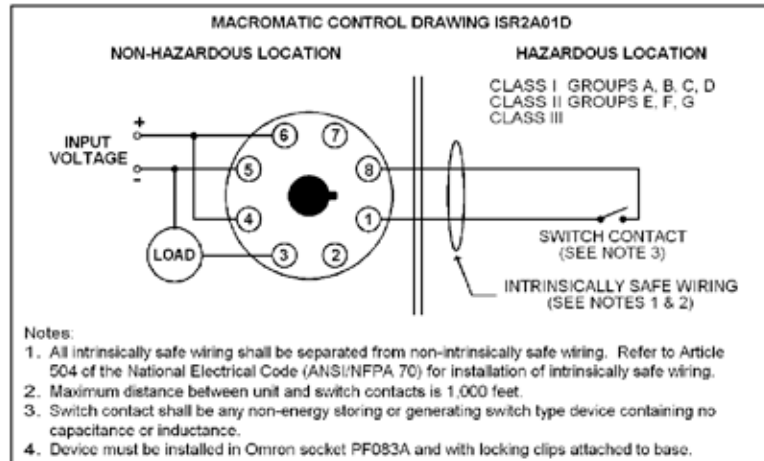
**Notes:**

1. All intrinsically safe wiring shall be separated from non-intrinsically safe wiring. Refer to Article 504 of the National Electrical Code (ANSI/NFPA 70) for installation of intrinsically safe wiring.
2. Maximum distance between unit and switch contacts is 1,000 feet.
3. Switch contact shall be any non-energy storing or generating switch type device containing no capacitance or inductance.
4. Device must be installed in Omron socket PF083A and with locking clips attached to base.

DIMENSIONS

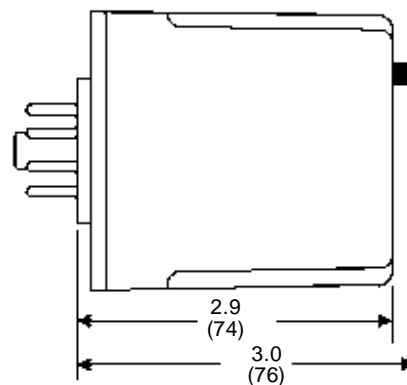
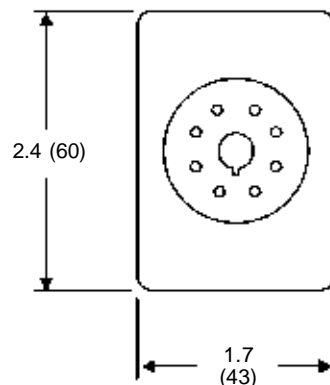

All Dimensions in Inches (Millimeters)

TIME DELAY RELAYS

PRODUCT SUMMARY

Macromatic offers a wide variety of time delay relays and accessories. Each one has different features and operating characteristics, allowing you to choose the exact product to meet your needs. Our time delay relays are available in either programmable or non-programmable versions. We offer both single or multiple function time delay relays. Choose between SPDT or DPDT relay outputs. Time delay relays are available as plug-in units for use with industry standard 8 & 11 pin octal or 11 pin blade sockets. They also come in 1/16 DIN & 17.5mm mounting configurations. Choose between analog or digital-set time delay relays. Refer to the Selection Table on these two pages for more information.











	Time Ranger Multi-Range Programmable Plug-in	Standard Non-Programmable Single-Range Plug-in	Time Ranger Digital-Set Multi-Range Programmable Plug-in	Time Ranger Digital-Set Multi-Range Programmable Plug-in
Series	TR-6	TR-5	TD-7	TD-8
Timing Functions Available	<ul style="list-style-type: none"> * On Delay * Interval On * Flasher * Off Delay * Single Shot * Watchdog * Repeat Cycle * Delayed Interval * True Off Delay 	<ul style="list-style-type: none"> * On Delay * Interval On * Flasher * Off Delay * Single Shot * Watchdog * Repeat Cycle * Delayed Interval * On Delay/True Off Delay 	Available as both multi-function & single-function <ul style="list-style-type: none"> * On Delay * Interval On * Flasher * Off Delay * Single Shot 	Available as both multi-function with 16 functions (Page 70) & single-function (Page 71)
Timing Ranges Available	16 field-programmable timing ranges covering up to 2 Hours (24 Hours on Dual Knob units) in one unit (True Off Delay has 8 programmable timing ranges up to 30 minutes)	11 separate timing ranges from 0.05 Seconds to 2 Hours	50ms - 999 Hours Programmable Time Range	100ms - 1,023 Hours (Multi-Function) or 100ms - 1,023 Minutes (Single-Function) Programmable Time Range
Output Contacts	DPDT 10A @ 240V AC 10A @ 30V DC 1/2HP @ 120/240V AC (N.O.) 1/3HP @ 120/240V AC (N.C.) B300/R300			
Input Voltages	12V AC/DC, 24V AC/DC, 120V AC/DC & 240V AC			
Approvals				
See Page	54-59	60-65	68 & 69	70-73

TIME DELAY RELAYS

PRODUCT SUMMARY

See pages 52 & 53 for a detailed description of all timing functions available. If you have any questions regarding the selection or application of time delay relays, either visit our on-line Technical Resource Center (www.macromatic.com) or call us at 800-238-7474.

Need modifications such as fixed time delays, remote adjustments or special pin configurations? We can do most of these modifications within our normal lead-times. See page 80 for more information.

	Compact Non-Programmable Single Range Plug-in	Spade Base Non-Programmable Single Range Plug-in	Time Ranger Digital-Set Multi-Function Multi-Range Programmable 1/16 DIN	Time Ranger Analog-Set Multi-Function Multi-Range Programmable 1/16 DIN	Analog-Set Multi-Function Multi-Range Programmable 17.5mm
Series	SS-6 & SS-8	SS-4	TAD	TAA	TE-881
					
Timing Functions Available	* On Delay * Interval On * Off Delay * Single Shot	* On Delay * Off Delay	10 Field-Selectable Functions in One Unit (See Page 74 for details)	Two Versions, Each with 6 Field-Selectable Functions in One Unit (See Page 76 for details)	10 Field-Selectable Functions in One Unit (See Page 78 for details)
Timing Ranges Available	6 separate timing ranges from 0.02 to 300 Seconds	3 separate timing ranges from 0.1 to 300 Seconds	10ms to 9,990 Hours programmable timing range	10ms to 100 Hours programmable timing range	100ms to 10 Days programmable timing range
Output Contacts	SPDT 5A @ 120V AC 5A @ 28V DC 1/6HP @ 120V AC	DPDT 12A @ 240V AC 12A @ 30V DC 1/2HP @ 240V AC B300/R300	SPDT 5A @ 250V AC	DPDT 3A @ 250V AC	SPDT 16A @ 240V AC 16A @ 24V DC
Input Voltages	12V AC/DC, 24V AC/DC & 120V AC	24V AC/DC & 120V AC/DC	Universal 24-240V AC/ DC in one unit	Universal 24-240V AC/ DC in one unit	Universal 12-240V AC/ DC in one unit
Approvals					
See Page	66	67	74-75	76-77	78-79

TIME DELAY RELAYS

DEFINITION OF TIMING FUNCTIONS

Understanding the differences between all the functions available in time delay relays can sometimes be a daunting task. To begin with, time delay relays are simply control relays with a time delay built in. Their purpose is to control an event based on time.

Typically, time delay relays are initiated or triggered by one of two methods:

- ◆ application of input voltage (On Delay, Interval On, Flasher, Repeat Cycle & Delayed Interval)
- ◆ opening or closing of a trigger signal (Off Delay, Single Shot, Watchdog & Triggered Delayed Interval)

These trigger signals can be one of two designs: a control switch (dry contact), i.e., limit switch, push button, float switch, etc., or by voltage (commonly known as a power trigger).

To help understand, some definitions are important:

- ◆ Input Voltage - control voltage applied to the input terminals. Depending on the function, input voltage will either initiate the unit or make it ready to initiate when a trigger signal is applied.
- ◆ Trigger Signal - on certain timing functions, a trigger signal is used to initiate the unit after input voltage has been applied. As noted above, this trigger signal can either be a control switch (dry contact switch) or a power trigger (voltage).
- ◆ Output (Load) - every time delay relay has an internal relay (usually mechanical) with contacts that open & close to control the load. They are represented by the dotted lines in the wiring diagrams. Note that the user must provide the voltage to power the load being switched by the output contacts of the time delay relay.

Below and on the following page are both written and visual descriptions on how the common timing functions operate. A Timing Chart shows the relationship between Input Voltage, Trigger Signal (if present) and Output Contacts. If you cannot find a product to fit your requirements or have any questions, Macromatic's Application Engineers offer technical information along with product selection and application assistance. Just call us at 800-238-7474 or e-mail us at tech-help@macromatic.com.

Function	Operation	Timing Chart
ON DELAY Delay on Operate Delay on Make	Upon application of input voltage, the preset time begins. At the end of the preset time, the relay is energized. Input voltage must be removed and reapplied to reset the time delay & de-energize the relay.	
INTERVAL ON Interval	Upon application of input voltage, the relay is energized and the preset time begins. At the end of the preset time, the relay is de-energized. Input voltage must be removed and reapplied to reset the time delay.	
OFF DELAY Delay on Release De-Energization Delay on Drop-Out	Upon application of input voltage, the time delay relay is ready to accept trigger signals. Upon application of the trigger signal, the relay is energized. Upon release of the trigger signal, the preset time begins. At the end of the preset time, the relay is de-energized. Any application of the trigger signal during the preset time will keep the relay energized & reset the time delay.	
SINGLE SHOT One Shot Momentary Interval	Upon application of input voltage, the time delay relay is ready to accept trigger signals. Upon application of the trigger signal, the relay is energized and the preset time begins. During the preset time, the trigger signal is ignored. The time delay relay is reset by applying the trigger signal when the relay is not energized.	

TIME DELAY RELAYS

DEFINITION OF TIMING FUNCTIONS

Function	Operation	Timing Chart
WATCHDOG Retriggerable Single Shot	Upon application of input voltage, the time delay relay is ready to accept trigger signals. Upon application of the trigger signal, the relay is energized and the preset time begins. At the end of the preset time, the relay is de-energized unless the trigger signal is closed and opened prior to time out (before preset time elapses). Continuous cycling of the trigger signal at a rate faster than the preset time will cause the relay to remain energized.	
FLASHER	Upon application of input voltage, the preset time (T1) begins. At the end of the preset time, the relay is energized and remains in that condition for the preset time (T1). At the end of this time, the relay is de-energized and the sequence repeats until input voltage is removed.	
REPEAT CYCLE Off/On Delay	Upon application of input voltage, a preset delay begins (OFF). At the end of the preset delay, the relay is energized and remains in that condition for a second, independently adjustable preset time (ON). At the end of this time, the relay is de-energized and the sequence repeats until input voltage is removed.	
REPEAT CYCLE On/Off Delay	Upon application of input voltage, the relay is energized and a preset delay begins (ON). At the end of the preset delay, the relay is de-energized and remains in that condition for a second, independently adjustable preset time (OFF). At the end of this time, the relay is energized and the sequence repeats until input voltage is removed.	
DELAYED INTERVAL Single Cycle	Upon application of input voltage, a preset delay begins (OFF). At the end of the preset delay, the relay is energized and remains in that condition for a second, independently adjustable preset time (ON). At the end of the second preset time, the relay is de-energized. Input voltage must be removed and reapplied to reset the time delay relay.	
DELAYED INTERVAL (TRIGGERED) Single Cycle	Upon application of input voltage, the time delay relay is ready to accept trigger signals. Upon application of the trigger signal, a preset delay begins (OFF). At the end of the preset delay, the relay is energized and remains in that condition for a second, independently adjustable preset time (ON). At the end of the second preset time, the relay is de-energized. During both the OFF time & the ON time, the trigger signal is ignored.	
TRUE OFF DELAY	Upon application of input voltage, the relay is energized. When the input voltage is removed, the preset time begins. At the end of the preset time, the relay is de-energized. Voltage must be applied for a minimum of 0.1 seconds to assure proper operation. Any application of the input voltage during the preset time will keep the relay energized & reset the time delay. No external trigger switch is required.	

TIME DELAY RELAYS

**TIME RANGER™ PROGRAMMABLE
MULTI-RANGE PLUG-IN
ON DELAY, INTERVAL ON & FLASHER**



- ◆ Each unit has 16 timing ranges built-in
- ◆ Selecting a range is easy using a rotary switch (no math is required or DIP switches to set)
- ◆ Timing ranges up to 2 hours
- ◆ Uses industry-standard 8 pin octal sockets
- ◆ 10A DPDT output contacts



UL LISTED with appropriate socket

SINGLE KNOB UNITS

FUNCTION ■	INPUT VOLTAGE 50/60Hz.	PRODUCT NUMBER	WIRING/ SOCKETS
ON DELAY	120V AC/DC	TR-60222	8 PIN OCTAL 70169-D INPUT VOLTAGE DIAGRAM 1
	12V AC/DC	TR-60226	
	24V AC/DC	TR-60228	
	240V AC	TR-60221	
INTERVAL ON	120V AC/DC	TR-60522	
	12V AC/DC	TR-60526	
	24V AC/DC	TR-60528	
	240V AC	TR-60521	
FLASHER	120V AC/DC	TR-60822	
	12V AC/DC	TR-60826	
	24V AC/DC	TR-60828	
	240V AC	TR-60821	

■ See Pages 52 & 53 for definitions & explanations of Timing Functions.

Sockets & Accessories—Pages 81 & 82
Dimensions—Page 57

Application Data—Page 57
Standard Modifications—Page 80

TIMING RANGES

Select one of the 16 built-in time ranges by setting the rotary switch per a chart on the unit and adjust within that range using the knob on top:

SINGLE KNOB UNITS

Dial Setting	Timing Range
A	0.1 - 0.25 Sec.
B	0.2 - 0.5 Sec.
C	0.3 - 1 Sec.
D	0.5 - 2 Sec.
E	1 - 4 Sec.
F	2 - 8 Sec.
G	4 - 15 Sec.
H	8 - 30 Sec.
I	15 - 60 Sec.
J	30 - 120 Sec.
K	1 - 4 Min.
L	2 - 8 Min.
M	4 - 15 Min.
N	8 - 30 Min.
O	15 - 60 Min.
P	30 - 120 Min.



800-238-7474

www.macromatic.com
sales@macromatic.com

TIME DELAY RELAYS

**TIME RANGER™ PROGRAMMABLE
MULTI-RANGE PLUG-IN
OFF DELAY, SINGLE SHOT & WATCHDOG**



SINGLE KNOB UNITS

FUNCTION ■	INPUT VOLTAGE 50/60Hz.	PRODUCT NUMBER	WIRING/ SOCKETS
OFF DELAY Control Switch Trigger	120V AC/DC 12V AC/DC 24V AC/DC 240V AC	TR-61622 TR-61626 TR-61628 TR-61621	11 PIN OCTAL 70170-D DIAGRAM 2
SINGLE SHOT Control Switch Trigger	120V AC/DC 12V AC/DC 24V AC/DC 240V AC	TR-61522 TR-61526 TR-61528 TR-61521	
WATCHDOG Control Switch Trigger (Retriggerable Single Shot)	120V AC/DC 12V AC/DC 24V AC/DC 240V AC	TR-61322 TR-61326 TR-61328 TR-61321	
OFF DELAY Power Trigger	120V AC/DC 12V AC/DC 24V AC/DC 240V AC	TR-61922 TR-61926 TR-61928 TR-61921	11 PIN OCTAL 70170-D DIAGRAM 4
SINGLE SHOT Power Trigger	120V AC/DC 12V AC/DC 24V AC/DC 240V AC	TR-61722 TR-61726 TR-61728 TR-61721	
WATCHDOG Power Trigger (Retriggerable Single Shot)	120V AC/DC 12V AC/DC 24V AC/DC 240V AC	TR-61822 TR-61826 TR-61828 TR-61821	

- ◆ Each unit has 16 timing ranges built-in
- ◆ Selecting a range is easy using a rotary switch (no math is required or DIP switches to set)
- ◆ Timing ranges up to 2 hours
- ◆ Uses industry-standard 11 pin octal sockets
- ◆ 10A DPDT output contacts



■ See Pages 52 & 53 for definitions & explanations of Timing Functions.

Sockets & Accessories—Pages 81 & 82

Application Data—Page 57

Dimensions—Page 57

Standard Modifications—Page 80

TIMING RANGES

Select one of the 16 built-in time ranges by setting the rotary switch per a chart on the unit and adjust within that range using the knob on top:

SINGLE KNOB UNITS

Dial Setting	Timing Range
A	0.1 - 0.25 Sec.
B	0.2 - 0.5 Sec.
C	0.3 - 1 Sec.
D	0.5 - 2 Sec.
E	1 - 4 Sec.
F	2 - 8 Sec.
G	4 - 15 Sec.
H	8 - 30 Sec.
I	15 - 60 Sec.
J	30 - 120 Sec.
K	1 - 4 Min.
L	2 - 8 Min.
M	4 - 15 Min.
N	8 - 30 Min.
O	15 - 60 Min.
P	30 - 120 Min.



800-238-7474

www.macromatic.com
sales@macromatic.com

TIME DELAY RELAYS

**TIME RANGER™ PROGRAMMABLE
MULTI-RANGE PLUG-IN
REPEAT CYCLE & DELAYED INTERVAL**



- ◆ Each unit has 16 timing ranges built-in
- ◆ Selecting a range is easy using a rotary switch (no math is required or DIP switches to set)
- ◆ Timing ranges up to 24 hours
- ◆ Independently selectable & adjustable ON & OFF times on dual knob timers
- ◆ Uses industry-standard 8 or 11 pin octal sockets
- ◆ 10A DPDT output contacts



DUAL KNOB UNITS *

FUNCTION ■	INPUT VOLTAGE 50/60Hz.	PRODUCT NUMBER	WIRING/ SOCKETS
REPEAT CYCLE (OFF Time First Followed By ON Time and Repeating)	120V AC/DC 12V AC/DC 24V AC/DC 240V AC	TR-63122 TR-63126 TR-63128 TR-63121	8 PIN OCTAL 70169-D INPUT VOLTAGE DIAGRAM 1
REPEAT CYCLE (ON Time First Followed By OFF Time and Repeating)	120V AC/DC 12V AC/DC 24V AC/DC 240V AC	TR-65122 TR-65126 TR-65128 TR-65121	
DELAYED INTERVAL (OFF Time Followed by ON Time Followed by OFF State Until Reset)	120V AC/DC 12V AC/DC 24V AC/DC 240V AC	TR-66122 TR-66126 TR-66128 TR-66121	
DELAYED INTERVAL Control Switch Trigger (OFF Time / ON Time / OFF State Until Reset)	120V AC/DC 12V AC/DC 24V AC/DC 240V AC	TR-66522 TR-66526 TR-66528 TR-66521	11 PIN OCTAL 70170-D INPUT VOLTAGE DIAGRAM 2

* All Dual Knob units have independently selectable & adjustable ON & OFF times.
■ See Pages 52 & 53 for definitions & explanations of Timing Functions.

Sockets & Accessories—Pages 81 & 82

Application Data—Page 57

Dimensions—Page 57

Standard Modifications—Page 80

TIMING RANGES

Select one of the 16 built-in time ranges by setting the rotary switch per a chart on the unit and adjust within that range using the knob on top:

DUAL KNOB UNITS

Dial Setting	Timing Range
A	0.6 - 2.5 Sec.
B	1.5 - 5 Sec.
C	2.5 - 10.5 Sec.
D	5 - 21 Sec.
E	10 - 42 Sec.
F	0.4 - 1.4 Min.
G	0.7 - 2.8 Min.
H	1.5 - 5.5 Min.
I	3 - 11 Min.
J	5.5 - 22.5 Min.
K	11 - 45 Min.
L	0.4 - 1.5 Hr.
M	0.8 - 3 Hr.
N	1.5 - 6 Hr.
O	3 - 12 Hr.
P	6 - 24 Hr.



800-238-7474

www.macromatic.com
sales@macromatic.com

TIME DELAY RELAYS

TIME RANGER™ PROGRAMMABLE MULTI-RANGE PLUG-IN APPLICATION DATA & DIMENSIONS

APPLICATION DATA

Voltage Tolerance:

AC Operation: +10/-15% of nominal at 50/60 Hz.

DC Operation: +10/-15% of nominal.

Load (Burden):

2 VA

Setting Accuracy:

Maximum Setting (Adjustable): +5%, -0%

Minimum Setting (Adjustable): +0%, -50%

Repeat Accuracy (constant voltage and temperature):

> 2 Seconds Delay ±0.1%

0.1 - 2 Seconds Delay ±2%

Reset Time:

On Delay/Interval/Repeat Cycle/Delayed Interval: 0.1 Seconds

Off Delay/Single Shot/Watchdog/

Triggered Delayed Interval: 0.04 Seconds

Start-up Time:

(Time from when power is applied until unit is timing)

120 & 240V units 0.05 Seconds

12, 24 & 48V units 0.08 Seconds

Maintain Function Time:

(Time unit continues to time after power is removed)

0.01 Seconds for all units

Temperature:

12-120V Input Voltage: -28° to 65°C (-18° to 150°F)

240V Input Voltage: -28° to 50°C (-18° to 122°F)

Insulation Voltage:

2,000 volts

Output Contacts:

DPDT 10A @ 240V AC/30V DC,

1/2HP @ 120/240V AC (N.O.), 1/3HP @ 120/240V AC (N.C.)

B300 & R300; AC15 & DC13

Life:

Mechanical: 10,000,000 operations

Full Load: 100,000 operations

Compatibility:

On all units triggered by input voltage or by a control switch, do not use a solid state switch to initiate the timing sequence—problems with leakage current could occur. On all units with a power trigger, do not use a solid state switch with leakage current exceeding 0.5ma. Contact Macromatic Controls for additional information.

Triggering Off Delay, Single Shot or Watchdog Units:

Timing sequence must be initiated only after input voltage is applied to unit. Minimum required trigger switch closure time is 0.1 seconds.

Approvals:



File #E109466



File #LR45565



Low Voltage &
EMC Directives
EN60947-1, EN60947-5-1



IND. CONET. EQUIP.
LISTED
with
appropriate
socket
File #E109466

DIMENSIONS

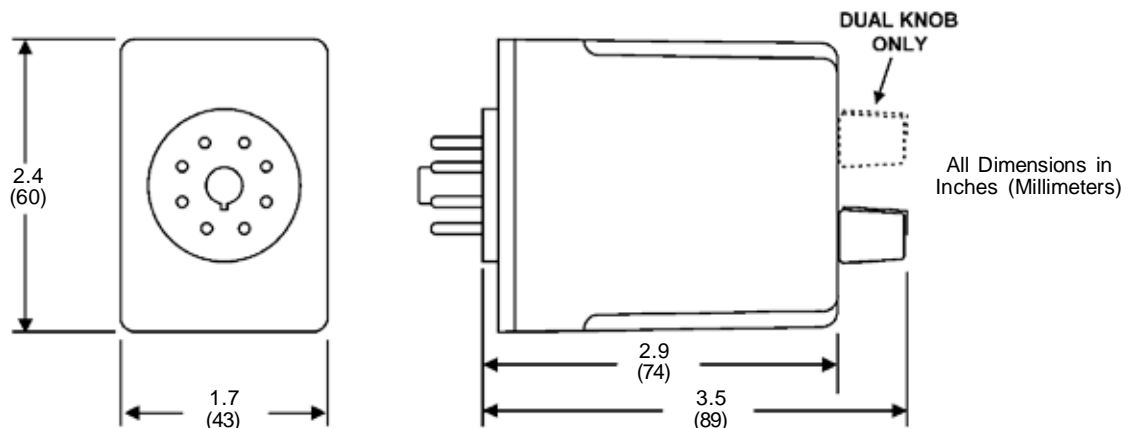

TIME DELAY RELAYS

TIME RANGER™ PROGRAMMABLE PLUG-IN TRUE OFF DELAY



- ◆ Provides Off Delay function without requiring input voltage during Off time delay
- ◆ Duplicates operation of pneumatic Off Delay timers
- ◆ Each unit has 8 timing ranges built-in, covering 0.05 seconds to 30 minutes
- ◆ Selecting a range is easy using a rotary switch (no math is required or DIP switches to set)
- ◆ Uses industry-standard 8 pin octal socket
- ◆ 10A DPDT output contacts



Most electronic time delay relays with an off delay function require input voltage to be applied continuously in order to operate correctly. However, there are many applications where this is not possible--keeping a relay energized for some amount of time after input voltage has been removed. A true off delay product provides this function even when input voltage is removed. It duplicates the operation of the older off delay pneumatic time delay relays.

Operation of True Off Delay: Upon application of input voltage, the relay is energized. When the input voltage is removed, the preset time begins. At the end of the preset time, the relay is de-energized. **Voltage must be applied for a minimum of 0.1 second to assure proper operation.** Any application of the input voltage during the preset time will keep the relay energized & reset the time delay. No external trigger switch is required.

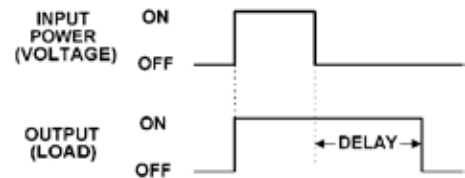

INPUT VOLTAGE 50/60Hz.	TIMING RANGE	PRODUCT NUMBER	WIRING/ SOCKETS
120V AC/DC	0.05 Sec. - 30 Min.	TR-60622	8 PIN OCTAL 70169-D INPUT VOLTAGE DIAGRAM 1
24V AC/DC	0.05 Sec. - 30 Min.	TR-60628	
240V AC	0.05 Sec. - 30 Min.	TR-60621	

Sockets & Accessories—Pages 81 & 82
Dimensions—Page 59

Application Data—Page 59
Standard Modifications—Page 80

TIMING RANGES

Select one of the 8 built-in time ranges by setting the rotary switch per the chart on the unit or below and adjust within that range using the knob on top:

Dial Setting	Timing Range
A	0.05 - 5 Sec.
B	0.1 - 10 Sec.
C	0.3 - 30 Sec.
D	0.6 - 60 Sec.
E	1.8 - 180 Sec.
F	3 - 300 Sec.
G	0.1 - 10 Min.
H	0.3 - 30 Min.



800-238-7474

www.macromatic.com
sales@macromatic.com

TIME DELAY RELAYS

TIME RANGER™ PROGRAMMABLE PLUG-IN

TRUE OFF DELAY

APPLICATION DATA & DIMENSIONS

APPLICATION DATA

Voltage Tolerance:

AC Operation: +10/-15% of nominal at 50/60 Hz.
 DC Operation: +10/-15% of nominal.

Load (Burden):

2 VA

Setting Accuracy:

Maximum Setting (Adjustable): +5%, -0%
 Minimum Setting (Adjustable): +0%, -50%

Repeat Accuracy (constant voltage and temperature):
 ±1% or 50ms, whichever is greater

Start-up Time:

(Time from when power is applied until unit is timing)
 0.05 Seconds

Temperature:

-28° to 65°C (-18° to 150°F)

Insulation Voltage:

2,000 volts

Output Contacts:

DPDT 10A @ 240V AC; 10A @ 28V DC,
 1/2 HP @ 240V AC, 1/4HP @ 120V AC
 B300 & R300

Life:

Mechanical: 2,000,000 operations
 Full Load: 100,000 operations

Approvals:



IMPORTANT: These relays are shipped from the factory in the OFF state. A shock to the relay during shipping or installation may cause it to change to the ON state. It is recommended that input voltage be applied to the product for at least 0.1 second and removed to cycle the unit to the OFF state prior to use in the application. Please note that it will take as long as the OFF Delay setting to reset the unit once input voltage has been removed.

DIMENSIONS

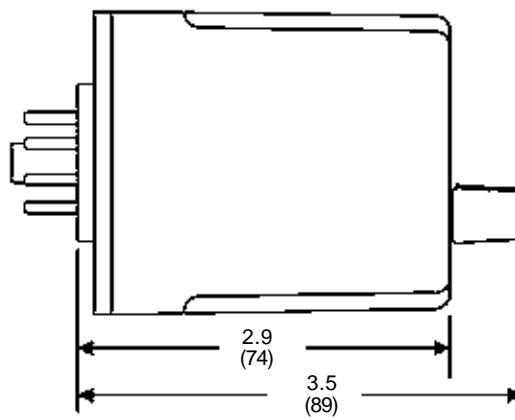
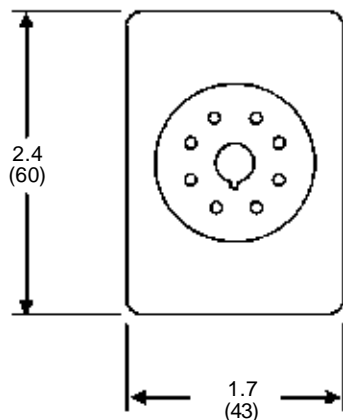

All Dimensions in Inches (Millimeters)

TIME DELAY RELAYS

NON-PROGRAMMABLE PLUG-IN

ON DELAY, INTERVAL & FLASHER



- ◆ Each unit has a single timing range
- ◆ Choose from 11 separate timing ranges from 0.02 Seconds to 2 Hours
- ◆ Uses industry-standard 8 pin octal sockets
- ◆ 10A DPDT output contacts



SINGLE KNOB UNITS

FUNCTION ■	INPUT VOLTAGE 50/60Hz.	PRODUCT NUMBER ** <small>COMPLETE PRODUCT NUMBER USING 2 DIGIT CODE FROM TABLE BELOW</small>	WIRING/ SOCKETS ▲
ON DELAY	120V AC/DC 12V AC/DC 24V AC/DC 240V AC	TR-50222-** TR-50226-** TR-50228-** TR-50221-**	8 PIN OCTAL ▲ 70169-D INPUT VOLTAGE DIAGRAM 1
INTERVAL ON	120V AC/DC 12V AC/DC 24V AC/DC 240V AC	TR-50522-** TR-50526-** TR-50528-** TR-50521-**	
FLASHER	120V AC/DC 12V AC/DC 24V AC/DC 240V AC	TR-50822-** TR-50826-** TR-50828-** TR-50821-**	

■ See Pages 52 & 53 for definitions & explanations of Timing Functions.

▲ Note: if these products are ordered with the Remote Adjust Potentiometer modification (suffix -Rx), they will require an 11 pin octal socket—see Page 80 for more information.

Sockets & Accessories—Pages 81 & 82

Dimensions—Page 63

Application Data—Page 63

Standard Modifications—Page 80

TIMING RANGES

** TIMING RANGE TABLE			
<small>COMPLETE PRODUCT NUMBER USING TWO DIGIT CODE FROM TABLE BELOW</small>			
<small>i.e., TR-50222-04</small>			
<u>Time Delay Range</u>	<u>Code</u>	<u>Time Delay Range</u>	<u>Code</u>
0.05 - 5 Sec.	04	3 - 300 Sec.	12
0.1 - 10 Sec.	05	0.1 - 10 Min.	22
0.3 - 30 Sec.	07	0.3 - 30 Min.	15
0.6 - 60 Sec.	08	0.6 - 60 Min.	16
1.2 - 120 Sec.	09	1.2 - 120 Min.	17
1.8 - 180 Sec.	10		

For Fixed Time Delay, add suffix "F" and time delay desired to basic Product Number, i.e., TR-50222-F5S is an On Delay with a time delay fixed at 5 seconds.

NOTE: Macromatic has obsoleted several time ranges that are no longer available on these products—for more information, please contact Macromatic.



800-238-7474

www.macromatic.com
sales@macromatic.com



TIME DELAY RELAYS

**NON-PROGRAMMABLE PLUG-IN
OFF DELAY, SINGLE SHOT & WATCHDOG**

SINGLE KNOB UNITS

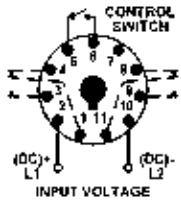
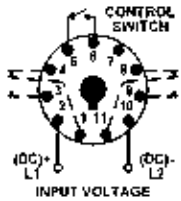
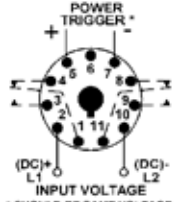
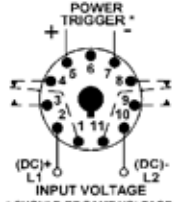
FUNCTION ■ ▲	INPUT VOLTAGE 50/60Hz.	PRODUCT NUMBER ** <small>COMPLETE PRODUCT NUMBER USING 2 DIGIT CODE FROM TABLE BELOW</small>	WIRING/ SOCKETS
OFF DELAY Control Switch Trigger	120V AC/DC 12V AC/DC 24V AC/DC 240V AC	TR-51622-** TR-51626-** TR-51628-** TR-51621-**	11 PIN OCTAL 70170-D 
SINGLE SHOT Control Switch Trigger	120V AC/DC 12V AC/DC 24V AC/DC 240V AC	TR-51522-** TR-51526-** TR-51528-** TR-51521-**	
WATCHDOG Control Switch Trigger (Retriggerable Single Shot)	120V AC/DC 12V AC/DC 24V AC/DC 240V AC	TR-51322-** TR-51326-** TR-51328-** TR-51321-**	
OFF DELAY Power Trigger	120V AC/DC 12V AC/DC 24V AC/DC 240V AC	TR-51922-** TR-51926-** TR-51928-** TR-51921-**	11 PIN OCTAL 70170-D 
SINGLE SHOT Power Trigger	120V AC/DC 12V AC/DC 24V AC/DC 240V AC	TR-51722-** TR-51726-** TR-51728-** TR-51721-**	
WATCHDOG Power Trigger (Retriggerable Single Shot)	120V AC/DC 12V AC/DC 24V AC/DC 240V AC	TR-51822-** TR-51826-** TR-51828-** TR-51821-**	

- ◆ Each unit has a single timing range
- ◆ Choose from 11 separate timing ranges from 0.02 Seconds to 2 Hours
- ◆ Uses industry-standard 11 pin octal sockets
- ◆ 10A DPDT output contacts



UL LISTED with appropriate socket

■ See Pages 52 & 53 for definitions & explanations of Timing Functions.

▲ 8 Pin SPDT versions of these functions are available—see Page 64.

Sockets & Accessories—Page 81 & 82
Dimensions—Page 63

Application Data—Page 63
Standard Modifications—Page 80

TIMING RANGES

** TIMING RANGE TABLE			
COMPLETE PRODUCT NUMBER USING TWO DIGIT CODE FROM TABLE BELOW			
i.e., TR-51622-04			
Time Delay Range	Code	Time Delay Range	Code
0.05 - 5 Sec.	04	3 - 300 Sec.	12
0.1 - 10 Sec.	05	0.1 - 10 Min.	22
0.3 - 30 Sec.	07	0.3 - 30 Min.	15
0.6 - 60 Sec.	08	0.6 - 60 Min.	16
1.2 - 120 Sec.	09	1.2 - 120 Min.	17
1.8 - 180 Sec.	10		

For Fixed Time Delay, add suffix "F" and time delay desired to basic Product Number, i.e., TR-51622-F5S is an Off Delay with a time delay fixed at 5 seconds.

NOTE: Macromatic has obsoleted several time ranges that are no longer available on these products—for more information, please contact Macromatic.



800-238-7474

www.macromatic.com
sales@macromatic.com

TIME DELAY RELAYS

NON-PROGRAMMABLE PLUG-IN REPEAT CYCLE & DELAYED INTERVAL



- ◆ Each unit has a single timing range
- ◆ Choose from 11 separate timing ranges from 0.02 Seconds to 2 Hours
- ◆ Independently adjustable ON & OFF times on dual knob timers
- ◆ Uses industry-standard 8 or 11 pin octal sockets
- ◆ 10A DPDT output contacts



DUAL KNOB UNITS *

FUNCTION ■	INPUT	PRODUCT	WIRING/ SOCKET
	VOLTAGE 50/60Hz.	NUMBER ** <small>COMPLETE PRODUCT NUMBER USING 2 DIGIT CODE FROM TABLE BELOW</small>	
REPEAT CYCLE (OFF Time First Followed By ON Time and Repeating)	120V AC/DC	TR-53122-**-	8 PIN OCTAL 70169-D INPUT VOLTAGE DIAGRAM 1
	12V AC/DC	TR-53126-**-	
	24V AC/DC	TR-53128-**-	
	240V AC	TR-53121-**-	
REPEAT CYCLE (ON Time First Followed By OFF Time and Repeating)	120V AC/DC	TR-55122-**-	11 PIN OCTAL 70170-D INPUT VOLTAGE DIAGRAM 2
	12V AC/DC	TR-55126-**-	
	24V AC/DC	TR-55128-**-	
	240V AC	TR-55121-**-	
DELAYED INTERVAL (OFF Time Followed by ON Time Followed by OFF State Until Reset)	120V AC/DC	TR-56122-**-	
	12V AC/DC	TR-56126-**-	
	24V AC/DC	TR-56128-**-	
	240V AC	TR-56121-**-	
DELAYED INTERVAL Control Switch Trigger (OFF Time Followed by ON Time Followed by OFF State Until Reset)	120V AC/DC	TR-56522-**-	
	12V AC/DC	TR-56526-**-	
	24V AC/DC	TR-56528-**-	
	240V AC	TR-56521-**-	

* All Dual Knob units have independently selectable & adjustable ON & OFF times. To order a Dual Knob unit with the same ON & OFF timing ranges, complete the Product Number by adding one two-digit code from the table below, i.e., a TR-55122-08 is a Repeat Cycle unit with both the ON time & OFF time adjustable between 0.6 - 60 seconds. To order a Dual Knob unit with different ON & OFF timing ranges, complete the Product Number by adding two different two-digit codes from the table below. The first suffix indicates the first timing range of the unit and the second suffix indicates the second timing range, i.e., a TR-53122-05-12 is a Repeat Cycle unit with an OFF timing range first of 0.1-10 seconds and an ON timing range second of 3-300 seconds.

- See Pages 52 & 53 for definitions & explanations of Timing Functions.

Sockets & Accessories—Pages 81 & 82

Application Data—Page 63

Dimensions—Page 63

Standard Modifications—Page 80

TIMING RANGES

** TIMING RANGE TABLE			
COMPLETE PRODUCT NUMBER USING TWO DIGIT CODE FROM TABLE BELOW			
i.e., TR-55122-04			
Time Delay Range	Code	Time Delay Range	Code
0.05 - 5 Sec.	04	3 - 300 Sec.	12
0.1 - 10 Sec.	05	0.1 - 10 Min.	22
0.3 - 30 Sec.	07	0.3 - 30 Min.	15
0.6 - 60 Sec.	08	0.6 - 60 Min.	16
1.2 - 120 Sec.	09	1.2 - 120 Min.	17
1.8 - 180 Sec.	10		

NOTE: Macromatic has obsoleted several time ranges that are no longer available on these products--for more information, please contact Macromatic.



800-238-7474

www.macromatic.com
sales@macromatic.com

TIME DELAY RELAYS

NON-PROGRAMMABLE PLUG-IN

APPLICATION DATA & DIMENSIONS

APPLICATION DATA

Voltage Tolerance:

AC Operation: +10/-15% of nominal at 50/60 Hz.

DC Operation: +10/-15% of nominal.

Load (Burden):

2 VA

Setting Accuracy:

Maximum Setting (Adjustable): +5%, -0%

Minimum Setting (Adjustable): +0%, -50%

Fixed Time Delay: > 2 Seconds $\pm 1\%$
0.1 - 2 Seconds $\pm 5\%$

Repeat Accuracy (constant voltage and temperature):

> 2 Seconds Delay $\pm 0.1\%$

0.1 - 2 Seconds Delay $\pm 2\%$

Reset Time:

On Delay/Interval/Repeat Cycle/Delayed Interval: 0.1 Seconds

Off Delay/Single Shot/Watchdog/

Triggered Delayed Interval: 0.04 Seconds

Start-up Time:

(Time from when power is applied until unit is timing)

120 & 240V units 0.05 Seconds

12, 24 & 48V units 0.08 Seconds

Maintain Function Time:

(Time unit continues to time after power is removed)

0.01 Seconds for all units

Temperature:

12-120V Input Voltage: -28° to 65°C (-18° to 150°F)

240V Input Voltage: -28° to 50°C (-18° to 122°F)

Insulation Voltage:

2,000 volts

Output Contacts:

DPDT 10A @ 240V AC/30V DC,

1/2HP @ 120/240V AC (N.O.), 1/3HP @ 120/240V AC (N.C.)

B300 & R300; AC15 & DC13

Life:

Mechanical: 10,000,000 operations

Full Load: 100,000 operations

Compatibility:

On all units triggered by input voltage or by a control switch, do not use a solid state switch to initiate the timing sequence—problems with leakage current could occur. On all units with a power trigger, do not use a solid state switch with leakage current exceeding 0.5ma. Contact Macromatic Controls for additional information.

Triggering Off Delay, Single Shot or Watchdog Units:

Timing sequence must be initiated only after input voltage is applied to unit. Minimum required trigger switch closure time is 0.1 seconds.

Approvals:



File #E109466



File #LR45565



Low Voltage &
EMC Directives
EN60947-1, EN60947-5-1



IND. CONT. EQUIP.
with
appropriate
socket
File #E109466

DIMENSIONS

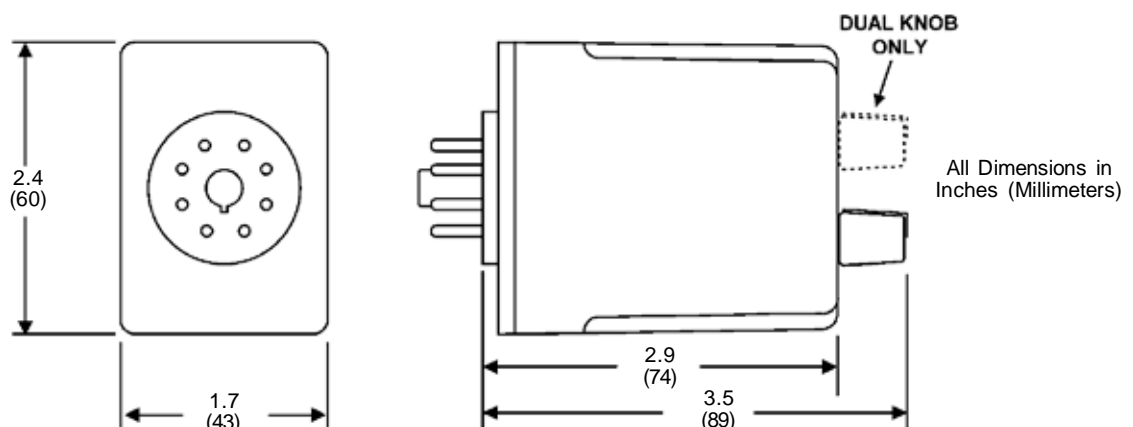

TIME DELAY RELAYS

**NON-PROGRAMMABLE PLUG-IN
8 PIN SPDT VERSIONS**
OFF DELAY, SINGLE SHOT & WATCHDOG



- ◆ These are 8 pin 10A SPDT versions of our standard 11 pin DPDT products
- ◆ Choose from 11 separate timing ranges from 0.02 Seconds to 2 Hours
- ◆ Uses industry-standard 8 pin octal socket



FUNCTION ■	INPUT VOLTAGE 50/60Hz.	PRODUCT NUMBER ** <small>COMPLETE PRODUCT NUMBER USING 2 DIGIT CODE FROM TABLE BELOW</small>	WIRING/ SOCKETS ▲
OFF DELAY Control Switch Trigger	120V AC/DC 12V AC/DC 24V AC/DC 240V AC	TR-51662-** TR-51666-** TR-51668-** TR-51661-**	8 PIN OCTAL 70169-D ▲
SINGLE SHOT Control Switch Trigger	120V AC/DC 12V AC/DC 24V AC/DC 240V AC	TR-51562-** TR-51566-** TR-51568-** TR-51561-**	
WATCHDOG Control Switch Trigger (Retriggerable Single Shot)	120V AC/DC 12V AC/DC 24V AC/DC 240V AC	TR-51362-** TR-51366-** TR-51368-** TR-51361-**	
OFF DELAY Power Trigger	120V AC/DC 12V AC/DC 24V AC/DC 240V AC	TR-51962-** TR-51966-** TR-51968-** TR-51961-**	
SINGLE SHOT PowerTrigger	120V AC/DC 12V AC/DC 24V AC/DC 240V AC	TR-51762-** TR-51766-** TR-51768-** TR-51761-**	
WATCHDOG Power Trigger (Retriggerable Single Shot)	120V AC/DC 12V AC/DC 24V AC/DC 240V AC	TR-51862-** TR-51866-** TR-51868-** TR-51861-**	

■ See Pages 52 & 53 for definitions & explanations of Timing Functions.

▲ Note: if these products are ordered with the Remote Adjust Potentiometer modification (suffix -Rx), they will require an 11 pin octal socket—see Page 80 for more information.

Sockets & Accessories—Pages 81 & 82

Application Data—Page 65

Dimensions—Page 65

Standard Modifications—Page 80

TIMING RANGES

** TIMING RANGE TABLE			
COMPLETE PRODUCT NUMBER USING TWO DIGIT CODE FROM TABLE BELOW			
i.e., TR-51662-04			
Time Delay Range	Code	Time Delay Range	Code
0.05 - 5 Sec.	04	3 - 300 Sec.	12
0.1 - 10 Sec.	05	0.1 - 10 Min.	22
0.3 - 30 Sec.	07	0.3 - 30 Min.	15
0.6 - 60 Sec.	08	0.6 - 60 Min.	16
1.2 - 120 Sec.	09	1.2 - 120 Min.	17
1.8 - 180 Sec.	10		

For Fixed Time Delay, add suffix "F" and fixed time delay desired to basic Product Number, i.e., TR-51662-F5S is an Off Delay with a time delay fixed at 5 seconds.

NOTE: Macromatic has obsoleted several time ranges that are no longer available on these products—for more information, please contact Macromatic.



800-238-7474

www.macromatic.com
sales@macromatic.com

TIME DELAY RELAYS

NON-PROGRAMMABLE PLUG-IN 8 PIN SPDT VERSIONS

APPLICATION DATA & DIMENSIONS

APPLICATION DATA

Voltage Tolerance:

AC Operation: +10/-15% of nominal at 50/60 Hz.
DC Operation: +10/-15% of nominal.

Load (Burden):

2 VA

Setting Accuracy:

Maximum Setting (Adjustable): +5%, -0%
Minimum Setting (Adjustable): +0%, -50%
Fixed Time Delay: > 2 Seconds ±1%
0.1 - 2 Seconds ±5%

Repeat Accuracy (constant voltage and temperature):

> 2 Seconds Delay ±0.1%
0.1 - 2 Seconds Delay ±2%

Reset Time:

Off Delay/Single Shot/Watchdog: 0.04 Seconds

Start-up Time:

(Time from when power is applied until unit is timing)
120 & 240V units 0.05 Seconds
12, 24 & 48V units 0.08 Seconds

Maintain Function Time:

(Time unit continues to time after power is removed)
0.01 Seconds for all units

Temperature:

12-120V Input Voltage: -28° to 65°C (-18° to 150°F)
240V Input Voltage: -28° to 50°C (-18° to 122°F)

Insulation Voltage:

2,000 volts

Output Contacts:

SPDT 10A @ 240V AC/30V DC,
1/2HP @ 120/240V AC (N.O.), 1/3HP @ 120/240V AC (N.C.)
B300 & R300; AC15 & DC13

Life:

Mechanical: 10,000,000 operations
Full Load: 100,000 operations

Compatibility:

On all units triggered by a control switch, do not use a solid state switch to initiate the timing sequence-problems with leakage current could occur. On all units with a power trigger, do not use a solid state switch with leakage current exceeding 0.5ma. Contact Macromatic Controls for additional information.

Triggering Off Delay, Single Shot or Watchdog Units:

Timing sequence must be initiated only after input voltage is applied to unit. Minimum required trigger switch closure time is 0.1 seconds.

Approvals:

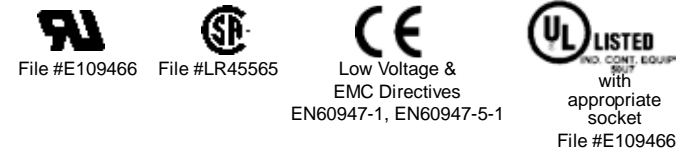

DIMENSIONS

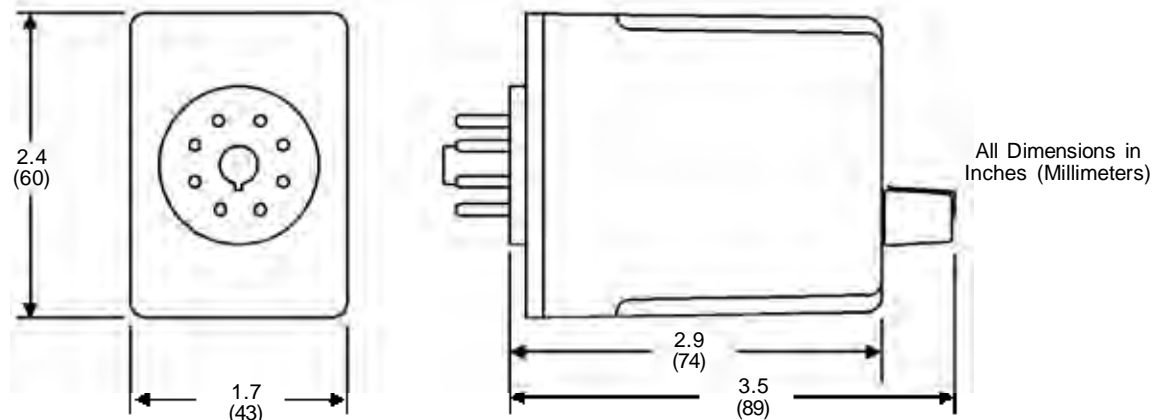

TIME DELAY RELAYS

COMPACT NON-PROGRAMMABLE PLUG-IN

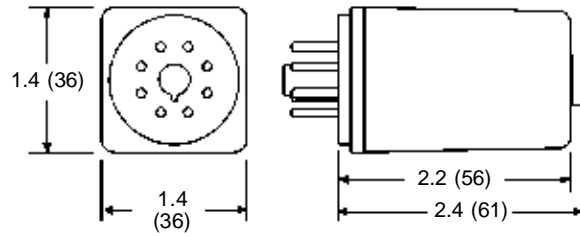

All Dimensions in
Inches (Millimeters)

- ◆ Compact, economical design with standard features for basic applications
- ◆ 6 separate timing ranges from 0.2 to 300 seconds
- ◆ 5A SPDT output contacts
- ◆ Uses industry-standard 8 pin octal sockets



TIMING RANGES

** TIMING RANGE TABLE	
COMPLETE PRODUCT NUMBER USING TWO DIGIT CODE FROM TABLE BELOW i.e., SS-6262-04	
Time Delay Range	Code
0.2 - 5 Sec.	04
0.5 - 15 Sec.	06
1 - 30 Sec.	07
2 - 60 Sec.	08
6 - 180 Sec.	10
10 - 300 Sec.	12

For Fixed Time Delay, add suffix "F" and time delay desired to basic Product Number, i.e., SS-6262-F5S is an On Delay fixed at 5 seconds.

FUNCTION ■	INPUT VOLTAGE	PRODUCT NUMBER ** <small>COMPLETE PRODUCT NUMBER USING 2 DIGIT CODE FROM TABLE BELOW LEFT</small>	WIRING/SOCKET ●
ON DELAY	120V AC 12V AC/DC 24V AC/DC	SS-6262-** SS-6266-** SS-6268-**	8 Pin Octal 70169-D INPUT VOLTAGE DIAGRAM 5
INTERVAL ON	120V AC 12V AC/DC 24V AC/DC	SS-8062-** SS-8066-** SS-8068-**	 INPUT VOLTAGE DIAGRAM 5
OFF DELAY	120V AC 12V AC/DC 24V AC/DC	SS-8562-** SS-8566-** SS-8568-**	8 Pin Octal 70169-D CONTROL SWITCH INPUT VOLTAGE DIAGRAM 6
SINGLE SHOT	120V AC 12V AC/DC 24V AC/DC	SS-8762-** SS-8766-** SS-8768-**	 CONTROL SWITCH INPUT VOLTAGE DIAGRAM 6

- See Pages 52 & 53 for definitions & explanations of Timing Functions.
- See Pages 81 & 82 for **Sockets & Accessories**.

APPLICATION DATA

Voltage Tolerance:

AC Operation: +10/-15% of nominal at 50/60 Hz.
DC Operation: +10/-15% of nominal.

Load (Burden):

Less than 3 VA

Setting Accuracy:

Maximum Setting: +10%, -0%
Minimum Setting: +0%, -50%
Fixed Time Delay: > 2 Seconds $\pm 2\%$
0.1 - 2 Seconds $\pm 5\%$

Repeat Accuracy:

> 2 Seconds Delay $\pm 2\%$
0.1 - 2 Seconds Delay $\pm 5\%$

Reset Time:

0.2 Seconds

Triggering Off Delay & Single Shot Units:

Timing sequence must be initiated only after input power is applied to unit. Minimum required trigger switch closure time is 0.1 seconds.

Temperature:

0° to 60°C (32° to 140°F)

Compatibility:

Do not use a solid state switch to initiate the timing sequence-problems with leakage current could occur. Contact Macromatic Controls for additional information.

Transient Protection:

10,000 volts for 20 microseconds

Output Contacts:

SPDT 5A @ 120V AC/28V DC,
1/6HP @ 120V AC

Life:

Mechanical: 10,000,000 operations
Full Load: 100,000 operations

Approvals:

File #E109466 with appropriate socket
File #E109466



800-238-7474

www.macromatic.com
sales@macromatic.com

TIME DELAY RELAYS

NON-PROGRAMMABLE WITH QUICK CONNECT TERMINALS

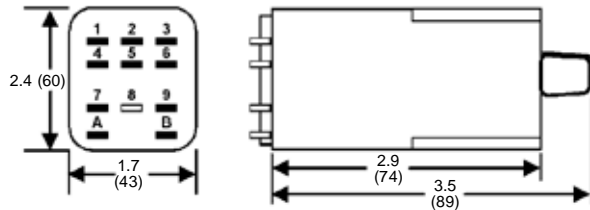

All Dimensions in Inches (Millimeters)



FUNCTION ■	INPUT VOLTAGE	TIME DELAY RANGE	PRODUCT NUMBER	WIRING/SOCKET ●
ON DELAY	120V AC/DC	0.1-10 Sec. 1-180 Sec. 3-300 Sec.	SS-40222-05 SS-40222-10 SS-40222-12	.187" Quick Connect 70171-D DIAGRAM 25
	24V AC/DC	0.1-10 Sec. 1-180 Sec. 3-300 Sec.	SS-40228-05 SS-40228-10 SS-40228-12	
OFF DELAY	120V AC/DC	0.1-10 Sec. 1-180 Sec. 3-300 Sec.	SS-41622-05 SS-41622-10 SS-41622-12	.187" Quick Connect 70171-D DIAGRAM 26
	24V AC/DC	0.1-10 Sec. 1-180 Sec. 3-300 Sec.	SS-41628-05 SS-41628-10 SS-41628-12	

- ◆ Industry-standard .187" quick connect terminals
- ◆ On Delay or Off Delay timing functions
- ◆ 3 separate timing ranges up to 300 seconds
- ◆ 12A DPDT output contacts



- See Pages 52 & 53 for definitions & explanations of Timing Functions.
- See Pages 81 & 82 for **Sockets & Accessories**

For Fixed Time Delay, add letter "F" and time delay desired to basic Product Number, i.e., SS-40222-F5S, is an On Delay with time delay fixed at 5 seconds.

APPLICATION DATA

Voltage Tolerance:

AC Operation: +10/-15% of nominal at 50/60 Hz.
DC Operation: +10/-15% of nominal.

Load (Burden):

Less than 3 VA.

Setting Accuracy:

Maximum Setting: +10%, -0%
Minimum Setting: +0%, -50%
Fixed Time Delay: > 2 Seconds ±2%
0.1 - 2 Seconds ±5%

Repeat Accuracy:

> 2 Seconds Delay ±2%
0.1 - 2 Seconds Delay ±5%

Compatibility:

Do not use a solid state switch to initiate the timing sequence-problems with leakage current could occur. Contact Macromatic Controls for additional information.

Recycle Time: 0.1 Seconds

Temperature: -28° to 65°C (-20° to 150°F)

Triggering Off Delay Timers:

Timing sequence must be initiated only after input power is applied to unit. Minimum required trigger switch closure time is 0.1 seconds.

Transient Protection:

10,000 volts for 20 microseconds

Output Contacts:

DPDT 12A @ 240V AC/30V DC,
1/2HP @ 240V AC

Life:

Mechanical: 10,000,000 operations
Full Load: 30,000 operations

Approvals:

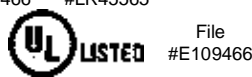

with appropriate socket



800-238-7474

www.macromatic.com
sales@macromatic.com

TIME DELAY RELAYS

TIME RANGER™ DIGITAL-SET PROGRAMMABLE MULTI-RANGE PLUG-IN



Multi-Function

Single-Function

The TD-7 series of time delay relays offer an easy and accurate way to select any time delay between 50ms & 999 hours. Programming is accomplished by using a pushbutton thumbwheel to select one of seven built-in time ranges and three pushbutton thumbwheels to digitally set the time delay required. This method provides a greater setting accuracy than is found on other units with an analog potentiometer. An LED indicates timing mode and time out condition.

The TD-7 series comes in two versions: a single function product or a multi-function product. The TD-781 multi-function unit has a fifth pushbutton thumbwheel to select one of five built-in functions.

- ◆ Available in either Single-Function or Multi-Function versions (with five user-selectable modes)
- ◆ Pushbutton Thumbwheels for digital set of time delay & function (TD-781 series only)
- ◆ 50ms - 999 hour programmable time range
- ◆ Uses industry-standard 8 or 11 pin octal sockets
- ◆ 10A DPDT output contacts
- ◆ LED indicates timing mode and time out conditions



800-238-7474

www.macromatic.com
sales@macromatic.com

Multi-Function Product

FUNCTION ■	INPUT VOLTAGE	PRODUCT NUMBER	WIRING/ SOCKETS
MULTI-FUNCTION (5 Field-Selectable Functions in one unit) ◆ On Delay ◆ Off Delay ◆ Interval On ◆ Single Shot ◆ Flasher	120V AC/DC	TD-78122	11 PIN OCTAL 70170-D DIAGRAM 121
	12V AC/DC	TD-78126	
	24V AC/DC	TD-78128	
	240V AC	TD-78121	

Single Function Products

FUNCTION ■	INPUT VOLTAGE	PRODUCT NUMBER	WIRING/ SOCKETS
ON DELAY	120V AC/DC	TD-70222	8 PIN OCTAL 70169-D DIAGRAM 1
	12V AC/DC	TD-70226	
	24V AC/DC	TD-70228	
	240V AC	TD-70221	
INTERVAL ON	120V AC/DC	TD-70522	11 PIN OCTAL 70170-D DIAGRAM 2
	12V AC/DC	TD-70526	
	24V AC/DC	TD-70528	
	240V AC	TD-70521	
FLASHER	120V AC/DC	TD-70822	11 PIN OCTAL 70170-D DIAGRAM 2
	12V AC/DC	TD-70826	
	24V AC/DC	TD-70828	
	240V AC	TD-70821	
OFF DELAY	120V AC/DC	TD-71622	11 PIN OCTAL 70170-D DIAGRAM 2
	12V AC/DC	TD-71626	
	24V AC/DC	TD-71628	
	240V AC	TD-71621	
SINGLE SHOT	120V AC/DC	TD-71522	11 PIN OCTAL 70170-D DIAGRAM 2
	12V AC/DC	TD-71526	
	24V AC/DC	TD-71528	
	240V AC	TD-71521	

■ See Pages 52 & 53 for definitions & explanations of Timing Functions.

Sockets & Accessories—Pages 81 & 82

Application Data & Dimensions—Page 69

TIME DELAY RELAYS

TIME RANGER™ DIGITAL-SET PROGRAMMABLE MULTI-RANGE PLUG-IN APPLICATION DATA & DIMENSIONS

APPLICATION DATA

Voltage Tolerance:

AC Operation: +10/-15% of nominal at 50/60 Hz.
DC Operation: +10/-15% of nominal.

Load (Burden):

3 VA

Setting Accuracy:

±1% of set time or ±50ms, whichever is greater.

Repeat Accuracy (constant voltage and temperature):

±0.1% of set time or ±0.02 seconds, whichever is greater.

Reset Time:

On Delay/Interval/Flasher: 0.1 Seconds
Off Delay/Single Shot: 0.04 Seconds

Start-up Time:

(Time from when power is applied until unit is timing)
120 & 240V units 0.05 Seconds
12, 24 & 48V units 0.08 Seconds

Maintain Function Time:

(Time unit continues to time after power is removed)
0.01 Seconds for all units

Temperature:

12-120V Input Voltage: -28° to 65°C (-18° to 150°F)
240V Input Voltage: -28° to 50°C (-18° to 122°F)

Insulation Voltage:

2,000 volts

Output Contacts:

DPDT 10A @ 240V AC/30V DC,
1/2HP @ 120/240V AC (N.O.), 1/3HP @ 120/240V AC (N.C.)
B300 & R300; AC15 & DC13

Life:

Mechanical: 10,000,000 operations
Full Load: 100,000 operations

Compatibility:

Do not use a solid state switch to initiate the timing sequence- problems with leakage current could occur. Contact Macro-matic Controls for additional information.

Triggering Off Delay or Single Shot Units:

Timing sequence must be initiated only after input voltage is applied to unit. Minimum required trigger switch closure time is 0.1 seconds.

LED:

Flasher Mode: Flashes during "ON" time; continuous on during "OFF" time

All Other Modes: Flashes during timing; continuous on after time out.

Approvals:

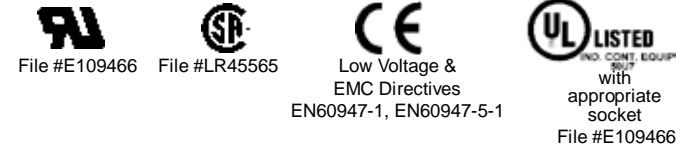

DIMENSIONS

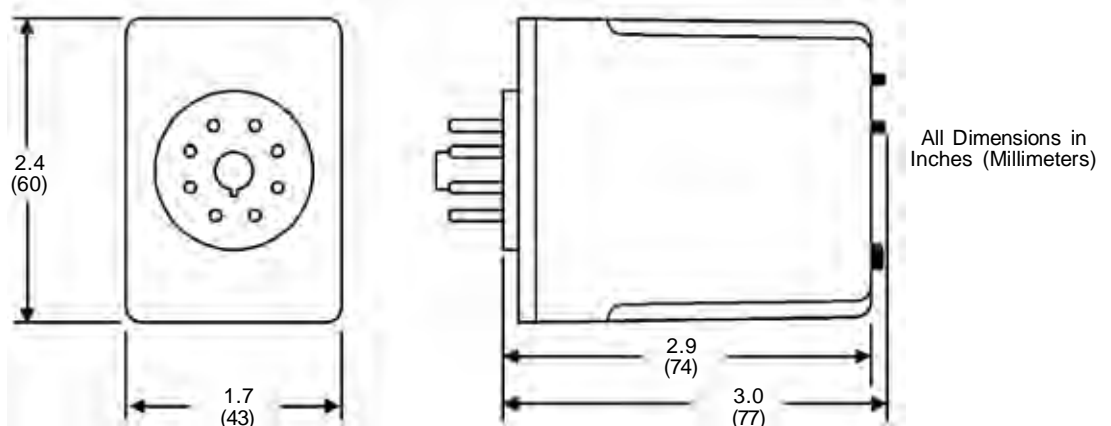

TIME DELAY RELAYS

TD-8 SERIES DIP-SWITCH DIGITAL-SET PLUG-IN MULTI-FUNCTION PROGRAMMABLE



- ◆ 16 functions in one unit
- ◆ DIP-Switches for accurate digital set of time delay & selection of function
- ◆ 100ms - 1,023 hours programmable time delay
- ◆ Uses industry-standard 11 pin octal socket



The TD-881 Series offers the digital-set accuracy of DIP-switch setting as well as the flexible programmability of a multi-function & multi-time range relay. These products provide an easy & accurate method to select any of 16 time delay functions and any time delay between 100ms and 1,023 hours. Programming is accomplished through the use of two 10-position DIP-switches. This product can literally replace hundreds of different catalog numbers, thereby reducing inventory requirements.

The following functions are available (see Page 73 for definitions & explanations):

Single Mode

- ◆ On Delay
- ◆ Flasher (OFF 1st)
- ◆ Off Delay
- ◆ Watchdog
- ◆ Triggered On Delay
- ◆ Interval On
- ◆ Flasher (ON 1st)
- ◆ Single Shot
- ◆ Single Shot (Trailing Edge)

Dual Mode

- ◆ Repeat Cycle (OFF 1st)
- ◆ Delayed Interval
- ◆ On Delay/Off Delay
- ◆ On Delay/Flasher
- ◆ Repeat Cycle (ON 1st)
- ◆ Triggered Delayed Interval
- ◆ Single Shot-Flasher

See Page 72 for instructions on how to program functions & time delay.

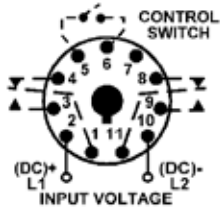
FUNCTION ■	INPUT VOLTAGE	PRODUCT NUMBER	WIRING/ SOCKETS
MULTI-FUNCTION (16 Field-Selectable Functions in one unit)	120V AC/DC 12V AC/DC 24V AC/DC 240V AC	TD-88122 TD-88126 TD-88128 TD-88121	11 PIN OCTAL 70170-D 

■ See Page 73 for definitions & explanations of Timing Functions.



800-238-7474

www.macromatic.com
sales@macromatic.com

Application Data & Dimensions-Page 72

TIME DELAY RELAYS

TD-8 SERIES DIP-SWITCH DIGITAL-SET PLUG-IN

SINGLE FUNCTION PROGRAMMABLE



Single Mode

Dual Mode

The TD-8 Series time delay relays offer an easy & accurate method to select any time delay between 100ms & 1,023 minutes. Programming is accomplished through the use of a 10-position DIP-switch. Each position is marked with a binary time increment. The required delay is selected by moving the switch of each increment to the ON position & adding their corresponding values (see examples below). This method provides a greater setting accuracy than is found on other units with an analog potentiometer. An LED indicates relay status.

- ◆ DIP-Switches for accurate digital set of time delay
- ◆ 100ms - 1,023 minute programmable time delay
- ◆ Uses industry-standard 8 or 11 pin octal sockets
- ◆ 10A DPDT output contacts
- ◆ LED indicates relay status



FUNCTION <small>SEE PAGE 73 FOR DEFINITIONS OF TIMING FUNCTIONS</small>	INPUT VOLTAGE 50/60Hz.	PRODUCT NUMBER ** <small>COMPLETE PRODUCT NUMBER USING 2 DIGIT CODE FROM TABLE BELOW</small>	WIRING/SOCKETS
ON DELAY	120V AC/DC 12V AC/DC 24V AC/DC 240V AC	TD-80222-** TD-80226-** TD-80228-** TD-80221-**	8 PIN OCTAL 70169-D
INTERVAL ON	120V AC/DC 12V AC/DC 24V AC/DC 240V AC	TD-80522-** TD-80526-** TD-80528-** TD-80521-**	
REPEAT CYCLE * (OFF Time First Followed By ON Time and Repeating)	120V AC/DC 12V AC/DC 24V AC/DC 240V AC	TD-83122-** TD-83126-** TD-83128-** TD-83121-**	
REPEAT CYCLE * (ON Time First Followed By OFF Time and Repeating)	120V AC/DC 12V AC/DC 24V AC/DC 240V AC	TD-85122-** TD-85126-** TD-85128-** TD-85121-**	
OFF DELAY Control Switch Trigger	120V AC/DC 12V AC/DC 24V AC/DC 240V AC	TD-81622-** TD-81626-** TD-81628-** TD-81621-**	
SINGLE SHOT Control Switch Trigger	120V AC/DC 12V AC/DC 24V AC/DC 240V AC	TD-81522-** TD-81526-** TD-81528-** TD-81521-**	11 PIN OCTAL 70170-D

* ON & OFF Time Ranges are the same. For different ON & OFF time ranges, contact Macromatic.

Application Data & Dimensions—Page 72

TIMING RANGES

** TIMING RANGE TABLE COMPLETE PRODUCT NUMBER USING TWO DIGIT CODE BELOW: i.e., TD-80222-40	
Time Delay Range	Code
0.1 - 102.3 Sec.	40
1 - 1,023 Sec.	41
10 - 10,230 Sec.	42
1 - 1,023 Min.	43

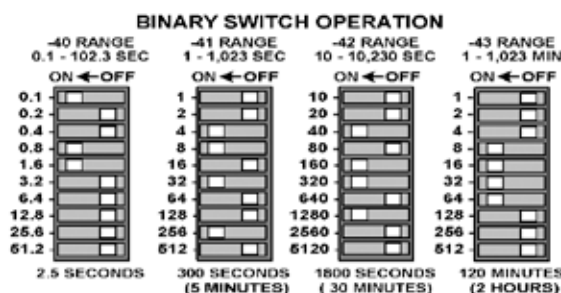

800-238-7474
www.macromatic.com
sales@macromatic.com

TIME DELAY RELAYS

TD-8 SERIES DIP-SWITCH DIGITAL-SET PLUG-IN

APPLICATION DATA & DIMENSIONS FOR MULTI- & SINGLE-FUNCTION PRODUCTS

PROGRAMMING FUNCTION & TIME DELAY (TD-881 Series Multi-Function Only)

Programming is accomplished through the use of two 10-position DIP-switches (see drawings at right). Switches A-D of the left-mounted DIP-switch are used to select a function (see the descriptions of how each function operates on Page 73 as a guide). Switches E-K of the same DIP-switch are used to select the time base. A convenient chart is on the side of the relay to clearly illustrate how to set both the function & time base.

The right-mounted 10-position DIP-switch is used to select the time delay within the time base selected with switches E-K from the first DIP-switch. Each position on the second DIP-switch is marked with a binary time increment. The required delay is selected by moving the switch of each increment to the ON position & adding their corresponding values (see diagram at right). Note that dual mode products can either have the same or different ON & OFF times.

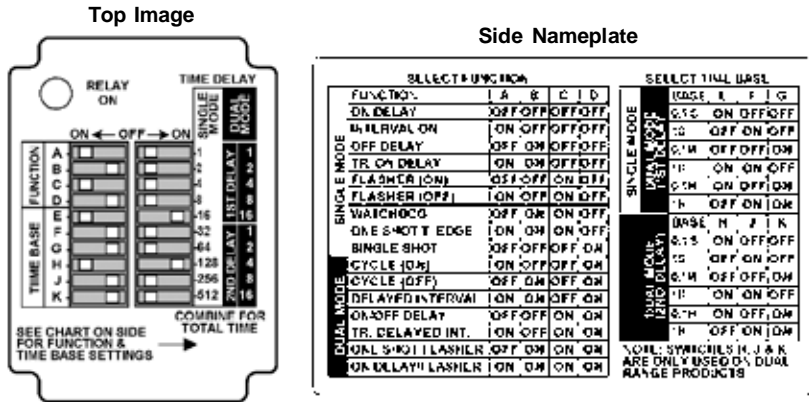

APPLICATION DATA

Voltage Tolerance:

AC Operation: +10/-15% of nominal at 50/60 Hz.
DC Operation: +10/-15% of nominal.

Load (Burden): 2 VA

Setting Accuracy:

±1% of set time or ±50ms, whichever is greater.

Repeat Accuracy (constant voltage and temperature):

±0.1% of set time or ±0.02 seconds, whichever is greater.

Reset Time:

All Functions Triggered by a Control Switch: 0.04 Seconds
All Other Functions: 0.1 Seconds

Start-up Time:

(Time from when power is applied until unit is timing)
120 & 240V units 0.05 Seconds
12, 24 & 48V units 0.08 Seconds

Maintain Function Time:

(Time unit continues to time after power is removed)
0.01 Seconds for all units

Insulation Voltage: 2,000 volts

Temperature: -28° to 65°C (-18° to 150°F)

Output Contacts:

DPDT 10A @ 240V AC/30V DC,
1/2HP @ 120/240V AC (N.O.), 1/3HP @ 120V AC (N.C.)
B300 & R300; AC15 & DC13

Life:

Mechanical: 10,000,000 operations
Full Load: 100,000 operations

Compatibility:

Do not use a solid state switch to initiate the timing sequence—problems with leakage current could occur. Contact Macromatic Controls for additional information.

Control Switch Triggered Units:

Minimum required trigger switch closure time is 0.02 seconds.

Approvals:



with appropriate socket
File #E109466

DIMENSIONS

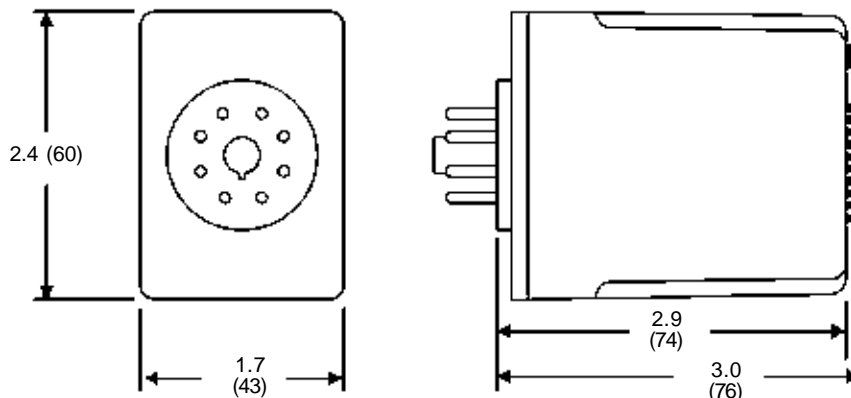

All Dimensions in Inches (Millimeters)

TIME DELAY RELAYS

TD-8 SERIES DIP-SWITCH DIGITAL-SET PLUG-IN

DEFINITION OF TIMING FUNCTIONS

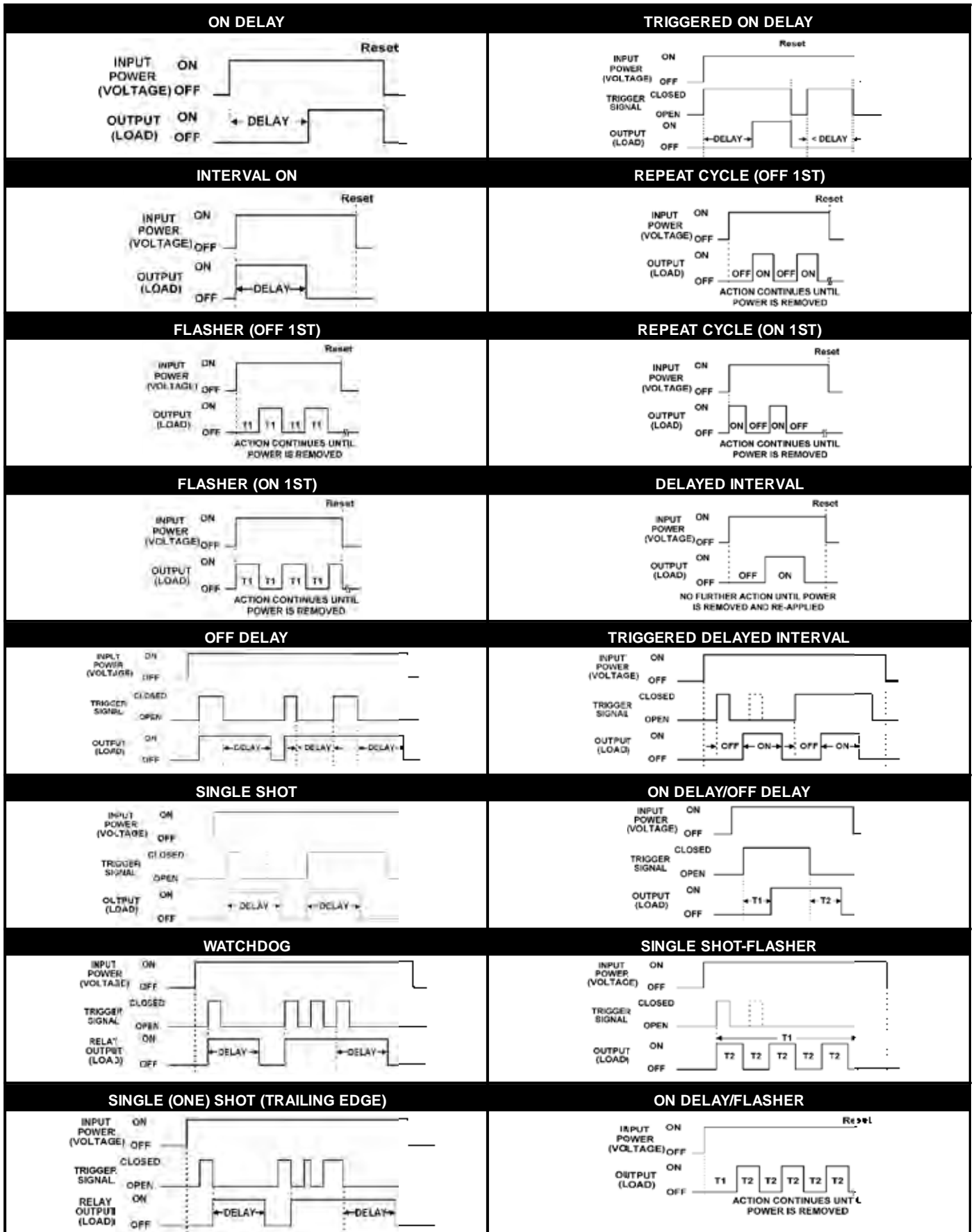

TIME DELAY RELAYS

TAD SERIES

DIGITAL-SET MULTI-FUNCTION MULTI-RANGE

1/16 DIN MOUNTING

All dimensions are
IN (mm)

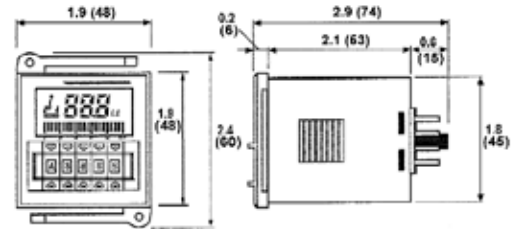

- ◆ Push-button thumbwheels for digital-setting of time delay & selection of function
- ◆ 10 field-selectable functions in one unit
- ◆ 10ms to 9,990 Hours programmable timing range
- ◆ Universal 24-240V AC/DC input voltage
- ◆ LCD display
- ◆ Panel, track or surface mounting
- ◆ 1/16 DIN style case (comes with panel-mounting adaptor)
- ◆ 5A SPDT output contacts
- ◆

MULTI-FUNCTION	INPUT VOLTAGE	PRODUCT NUMBER	WIRING/SOCKETS
10 FIELD-SELECTABLE FUNCTIONS◆	24-240V AC 50/60Hz & 24-240V DC	TAD1U	SEE DIAGRAMS ON PAGE 75 8 Pin Octal (See Below)

- ◆ Functions Include: On Delay (2 Versions), Interval, Flasher (2 Versions), Delayed Interval/Pulse, Off Delay, On/Off Delay, Single Shot & Accumulative On Delay (see Page 75 for additional details)
- See below for **Sockets & Accessories**.

APPLICATION DATA

Voltage Tolerance:
±10% of rated voltage

Load (Burden):
Less than 2.5 VA

Repeat Accuracy:
±0.01%, ±0.05 seconds (includes variation due to voltage and temperature changes)

Recycle Time:
0.2 seconds maximum

Temperature:
-10° to 55°C (14° to 131°F)

LCD Display: Shows time remaining in both digit & bar graph form--also shows relay status & time base. In addition, a switch on the bottom of the unit allows choice of timing up or timing down display.

Output Contacts:
5A SPDT Resistive @ 250V AC

Life:
Mechanical: 10,000,000 operations
Full Load: 100,000 operations

Approvals:
File #E170213

SOCKETS & ACCESSORIES

DESCRIPTION	PRODUCT NUMBER
8 Pin Octal Socket	70169-D
8 Pin Octal Socket (Back Mounting)	SR6P-M08G
Panel-Mounting Adaptor	Included

- For Surface or Track Mounting--See Pages 81 & 82 for additional information



PANEL CUTOUT

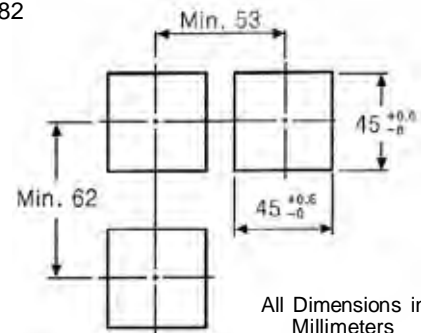

All Dimensions in
Millimeters



800-238-7474

www.macromatic.com
sales@macromatic.com

TIME DELAY RELAYS

TAD SERIES DIGITAL-SET MULTI-FUNCTION MULTI-RANGE

DEFINITION OF TIMING FUNCTIONS

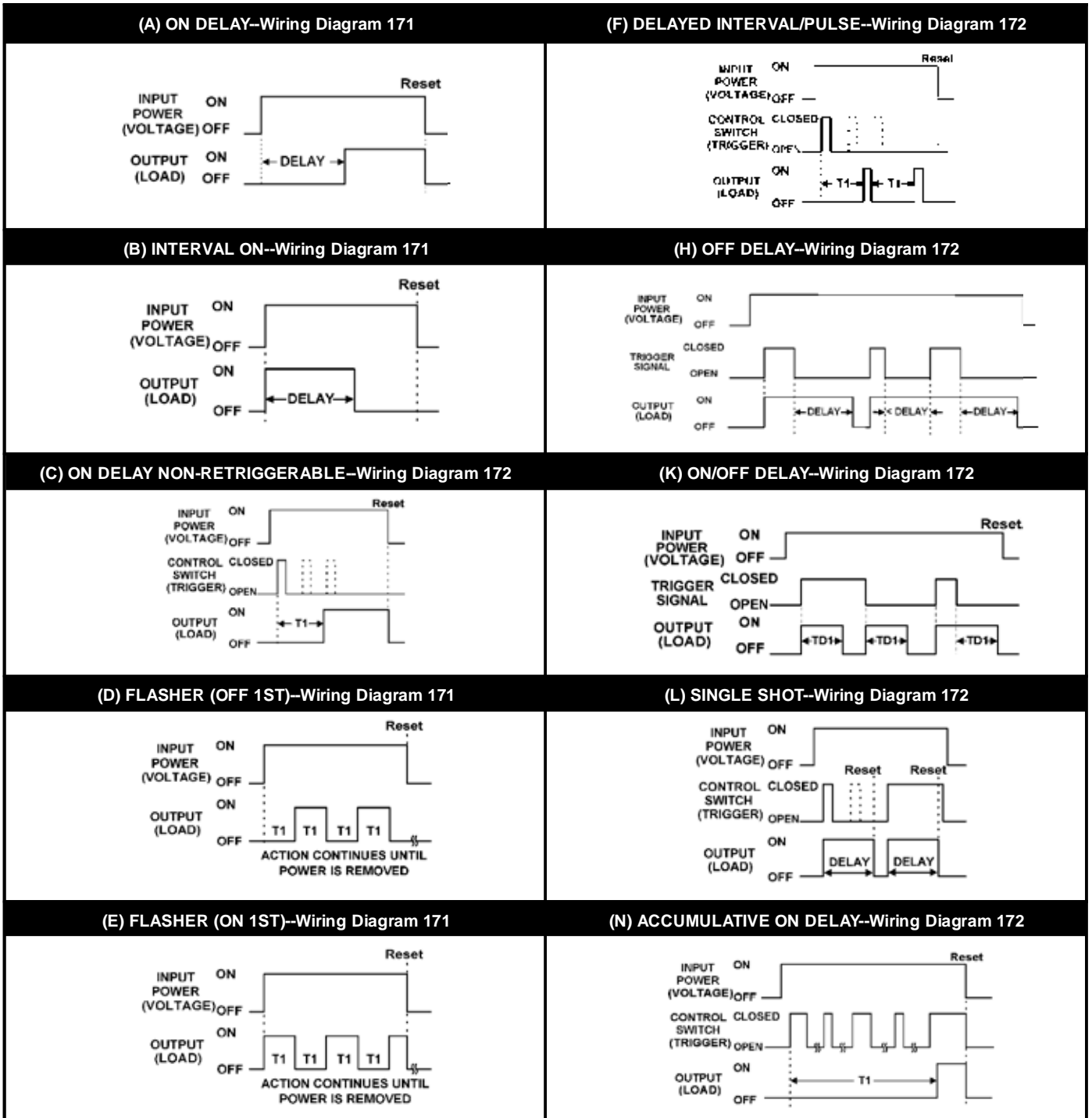

In addition to using the Trigger or Control Switch, some functions may also use a Reset and/or Inhibit switch--please contact Macromatic for additional information.

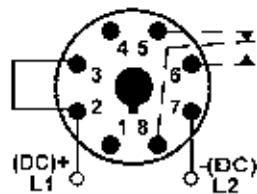

DIAGRAM 171

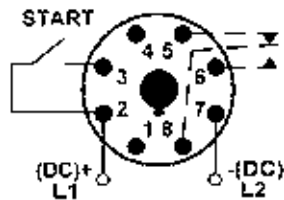

DIAGRAM 172

TIME DELAY RELAYS

TAA SERIES

ANALOG-SET MULTI-FUNCTION MULTI-RANGE

1/16 DIN MOUNTING

All dimensions are
IN (mm)

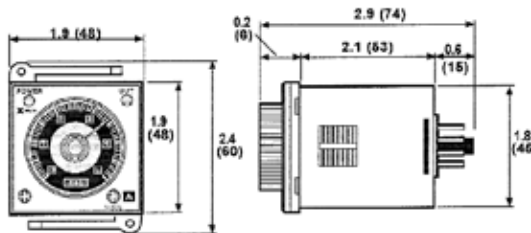

- ◆ 6 field-selectable functions in one unit
- ◆ Large dial for setting of time delay
- ◆ 50ms to 100 Hours programmable timing range
- ◆ Universal 24-240V AC/DC input voltage
- ◆ Panel, track or surface mounting
- ◆ 1/16 DIN style case (comes with panel-mounting adapter)
- ◆ 3A DPDT output contacts



MULTI-FUNCTION◆	INPUT VOLTAGE	PRODUCT NUMBER	WIRING/SOCKETS■
Includes: On Delay, Delayed Interval/Pulse, On Delay-Timed & Instantaneous, Flasher (OFF 1st), Flasher (ON 1st) & Interval On-Timed & Instantaneous	24-240V AC 50/60Hz & 24-240V DC	TAA1U	SEE DIAGRAMS ON PAGE 77 8 Pin Octal (See Below)
Includes: On Delay-Triggered, Off Delay, On/Off Delay, Flasher (OFF 1st)-Triggered, Flasher (ON 1st)-Triggered & Watchdog	24-240V AC 50/60Hz & 24-240V DC	TAA2U	SEE DIAGRAMS ON PAGE 77 11 Pin Octal (See Below)

■ See below for **Sockets & Accessories**.

◆ See Page 77 for additional details.

APPLICATION DATA

Voltage Tolerance:

±10% of rated voltage.

Load (Burden):

Less than 2.5 VA

Repeat Accuracy:

±0.01%, ±0.05 seconds (includes variation due to voltage and temperature changes).

Recycle Time:

0.2 seconds maximum.

Temperature:

-10° to 55°C (14° to 131°F)

LED Indicators:

One red LED indicates Input Voltage/Timing (flashing) & a second red LED indicates relay status.

Output Contacts:

3A DPDT Resistive @ 250V AC

Life:

Mechanical: 10,000,000 operations

Full Load: 100,000 operations

Approvals:



SOCKETS & ACCESSORIES

DESCRIPTION	PRODUCT NUMBER
8 Pin Octal Socket	: 70169-D■
8 Pin Octal Socket (Back Mounting)	: SR6P-M08G
11 Pin Octal Socket	: 70170-D■
11 Pin Octal Socket (Back Mounting)	: SR6P-M11G
Panel-Mounting Adaptor	: Included

■ For Surface or Track Mounting--See Pages 81 & 82 for additional information



SR6P-M08G



SR6P-M11G

PANEL CUTOUT

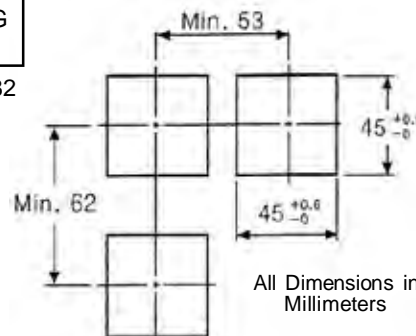

800-238-7474

www.macromatic.com
sales@macromatic.com

TIME DELAY RELAYS

TAA SERIES ANALOG-SET MULTI-FUNCTION MULTI-RANGE DEFINITION OF TIMING FUNCTIONS

TAA1U

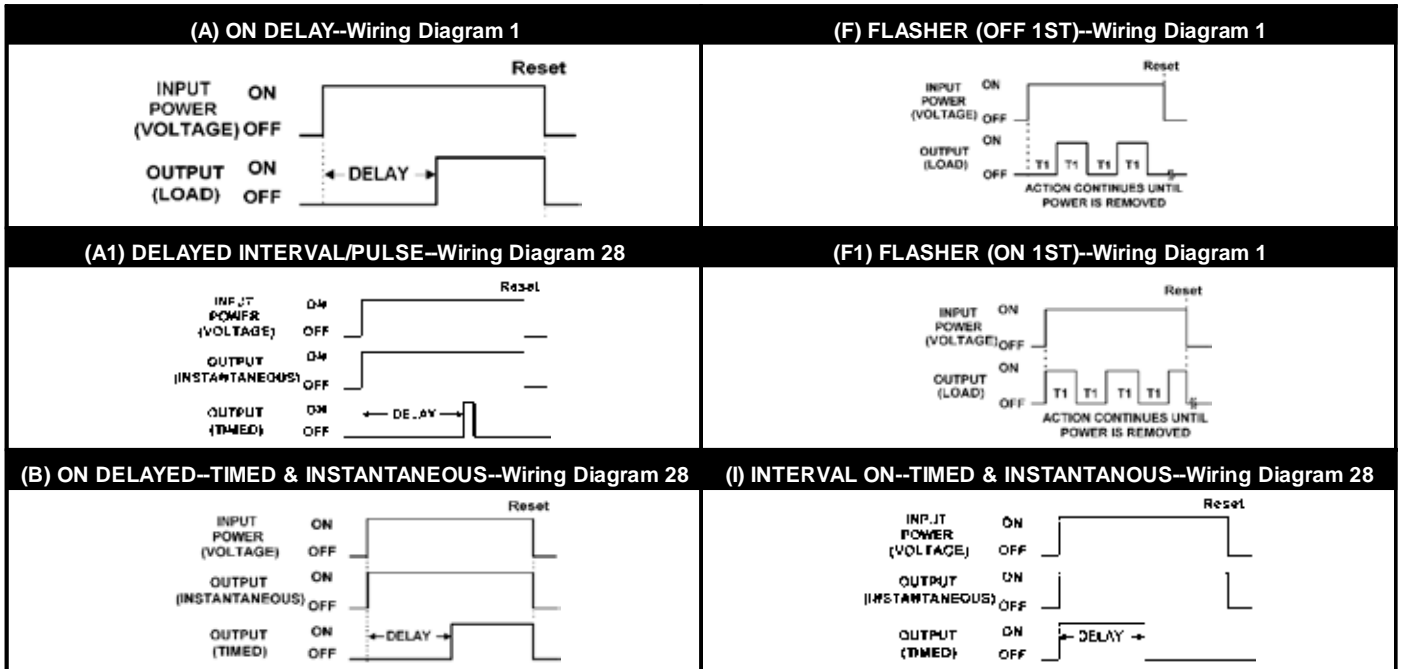

TAA2U

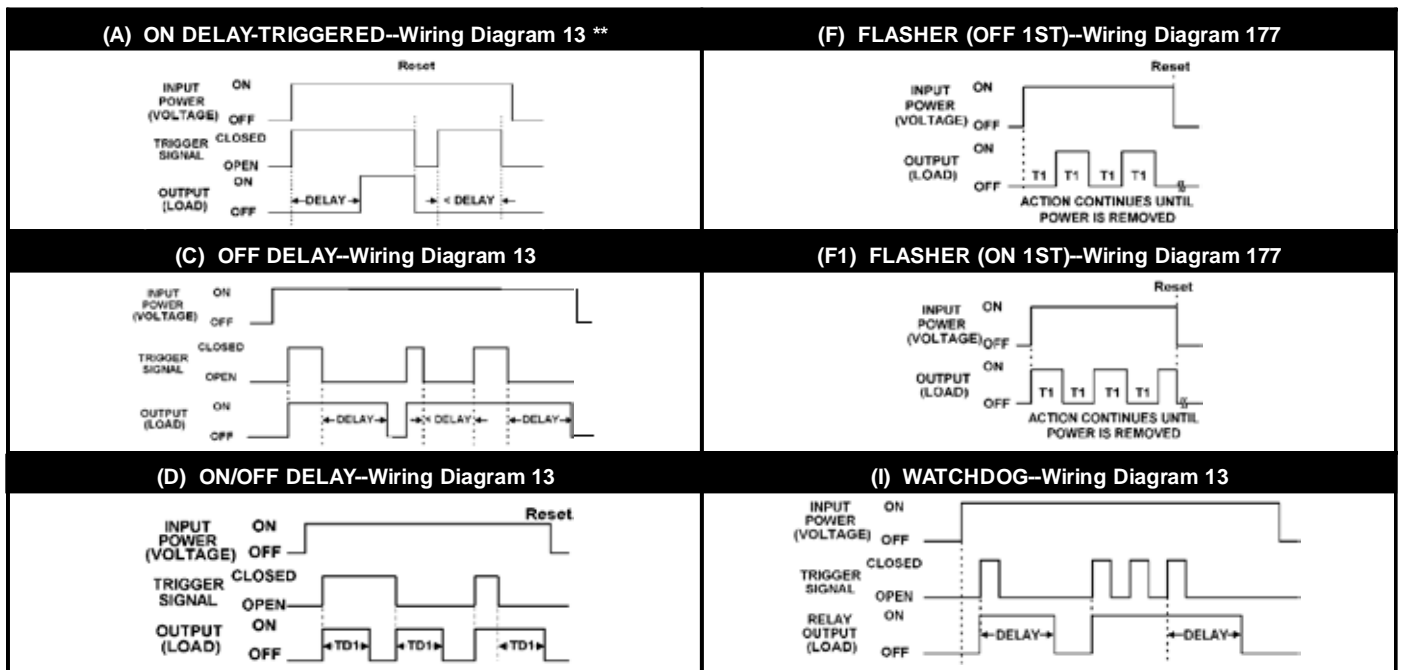

In addition to using the Trigger or Control Switch, some functions may also use a Reset and/or Inhibit switch--please contact Macromatic for additional information.
 ** Function (A) will also operate as standard Non-Triggered On Delay when using Wiring Diagram 177.

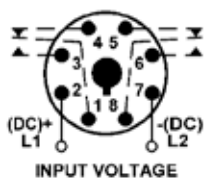

DIAGRAM 1

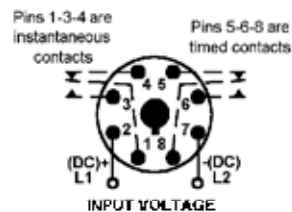

DIAGRAM 28

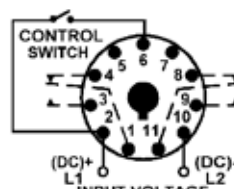

DIAGRAM 13

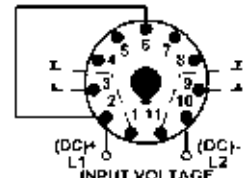

DIAGRAM 177

TIME DELAY RELAYS



TE-881 SERIES PROGRAMMABLE MULTI-FUNCTION MULTI-RANGE 17.5MM MODULAR ENCLOSURE



- ◆ 10 field-selectable functions in one unit
- ◆ Universal input voltage-- works on 12-240V AC/DC
- ◆ 0.1 second - 10 days programmable time delay
- ◆ LED's indicates output relay status & timing mode
- ◆ Compact 17.5mm enclosure mounts on 35mm DIN track
- ◆ 16A SPDT output contacts



The TE-8816U time delay relay offers 10 timing functions and a universal voltage input (12-240VAC/DC) with a programmable time range from 0.1 second – 10 days. It has 16A SPDT output contacts. A green LED indicates input voltage applied; a red LED blinks during timing & is steady when the output relay is energized. It has a compact 17.5mm enclosure which snaps on to 35mm DIN track. This saves space & installation time, which saves money. With all this flexibility, the TE-8816U truly does replace hundreds of separate time delay relays.

Catalog Number		TE-8816U
Input		
Voltage Range	12-240V AC/DC, 50/60Hz	
Operating Range	+10%, -15%	
Burden	3VA (AC), 1.7W (DC)	
Timing		
Number of Functions	10 (see descriptions on Page 79)	
Time Range	0.1 second-10 days (8 different time ranges built-in)	
Repeat Accuracy	+0.2%	
Reset Time	150ms	
Trigger Pulse Length	50ms	
Output		
Configuration	SPDT	
Rating	16A @ 240V AC, 16A @ 24V DC 1HP @ 240V AC, 1/2HP @ 120V AC, B300	
Contact Material	Silver Alloy	
Life	10 million operations mechanical; 100,000 electrical	
Other		
Agency Approval	 (File #E170213) 	
Temperature	Operating: -20° to 55° C (-4° to 131° F)	
LED Indication	Green-Input Voltage; Red-Timing or Relay ON	
Terminations	14 AWG (2.1mm ²)	



800-238-7474

www.macromatic.com
sales@macromatic.com

Application Data & Dimensions–Page 79

TIME DELAY RELAYS

TE-881 SERIES PROGRAMMABLE MULTI-FUNCTION MULTI-RANGE APPLICATION DATA & DIMENSIONS

FUNCTIONS

FUNCTION	DIAL SETTING	GRAPH
ON DELAY	A	
INTERVAL ON	B	
FLASHER (OFF 1ST)	C	
FLASHER (ON 1ST)	D	
OFF DELAY	E	
SINGLE SHOT	F	
OFF DELAY TRAILING EDGE (Non-Retriggerable)	G	
ON DELAY/OFF DELAY	H	
LATCHING RELAY	I	
PULSE GENERATOR (PULSE=0.5 SEC)	J	

DIMENSIONS

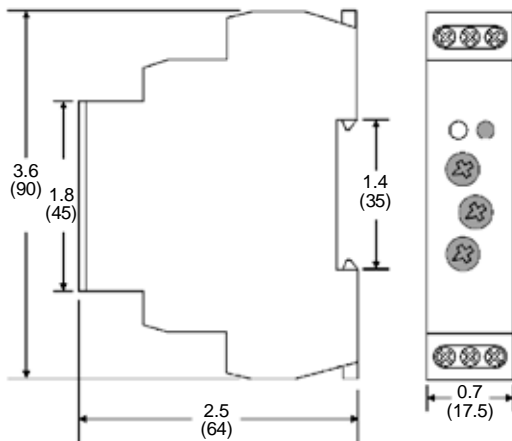

All Dimensions in
Inches (Millimeters)

CONNECTION DIAGRAM

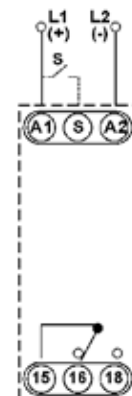

TIME DELAY RELAYS

STANDARD MODIFICATIONS

Many of our Catalog-Listed Time Delay Relays can be adapted for different applications. Below is a list of various Situations, Solutions and Ordering Information to illustrate many of these modifications. Please contact Macromatic if you have any questions or need additional information before ordering any products with these modifications. Other modifications are available. Contact Macromatic or go to www.macromatic.com for more information.

Situation: I know exactly what time delay I need and therefore, do not need a unit with an adjustable time range.

Solution: Macromatic offers products where the adjustment potentiometer is removed and the unit comes with one specific (non-adjustable) time range, i.e., 5 seconds, 1 minute, etc. These are products with a "fixed" time delay.

NOTE: applies to TR-5, SS-4, SS-6 & SS-8 Series products only.

To order: A time delay relay fixed at a factory set delay time, replace the normal two digit suffix indicating adjustable time range with the suffix Fxxt where xx is the specific time delay desired and t is the time interval (seconds, minutes or hours), i.e., a TR-51622-F10S is an Off Delay fixed at 10 Seconds.

Situation: I have an 11 pin time delay relay where all the pins match the wiring diagram shown in your catalog (and below) except the control switch (trigger switch) is connected to pins other than pins 5 and 6.

Solution: Macromatic can build a time delay relay triggered by a control switch (i.e., Off Delay, Single Shot, Watchdog) with any pin configuration required to meet your application. **NOTE:** applies to TR-5 Series products only.

To order: A time delay relay with a special control switch configuration, use the following chart to determine which suffix provides the correct configuration needed, i.e., a TR-51522-05T9 is a Single Shot with the control switch between pins 7 & 10 instead of 5 & 6:

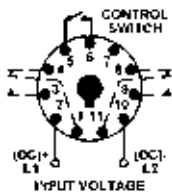

Standard 11 pin time delay relay, i.e., Off Delay, Single Shot, or Watchdog

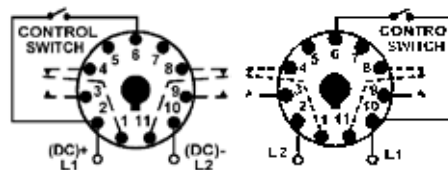

Standard 11 pin modified with a 2-6 control switch (Suffix T2)

Standard 11 pin modified with a 6-10 control switch (Suffix T8)

NOTE: The configuration of the input voltage and output contacts has not been changed.

Control Switch Connected To Pins	Add Suffix *	Control Switch Connected To Pins	Add Suffix *
2-5	T1	5-10	T6
2-6	T2	6-7	T7
2-7	T3	6-10	T8
5-7	T5	7-10	T9

* **NOTE:** These suffixes apply only to different control switch pin configurations. The input voltage and output pin configurations remain as shown at left. For other configurations, contact Macromatic.

Situation A: I want to mount a time delay relay in an enclosure, but would like to adjust the time delay from outside the enclosure instead of having to open the door.

Situation B: I need to replace a time delay relay that is already connected to a remote potentiometer with a known value.

Solution: Macromatic can build most time delay relays with an optional remote adjustment feature. The potentiometer usually supplied with the product is removed, and the product is setup for use with a customer-supplied remote potentiometer to be connected to pins 5 & 7. Units that are normally 8 pin will have an 11 pin configuration. Units that are normally 11 pin will have the control switch connected between pins 2 & 6 (instead of the standard 5 & 6). For other control switch pin configurations, contact Macromatic for ordering information. **NOTE:** applies to TR-5 & SS-4 Series products only.

To order: A time delay relay with a remote adjustment feature and an 11 pin header, use the following chart to determine which suffix matches the value of the remote potentiometer, i.e., a TR-50222-04R6 is an On Delay with an 11 pin header, setup for a 750K remote potentiometer to be connected to pins 5 & 7:

Remote Pot Value	Add Suffix	Remote Pot Value	Add Suffix
250K	R3	1.5M	R8
300K	R4	2M	R9
500K **	R5	2.5M	R10
750K	R6	5M	R11
1M	R7		



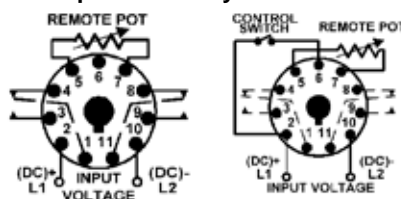







** **NOTE:** A 500K potentiometer (R5) is the only value that can be used with a *Time Ranger* Programmable Time Delay Relay (those catalog numbers that begin with a TR-6).

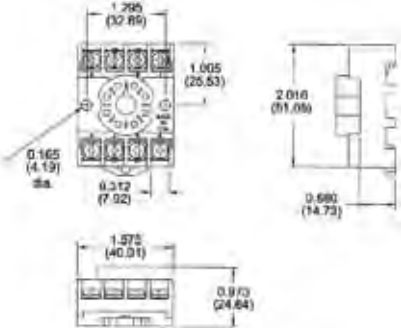

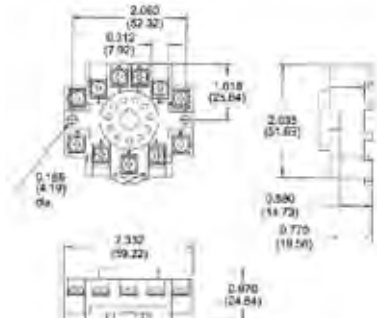
Normal 8 pin product with 11 pin configuration for Remote Adjust

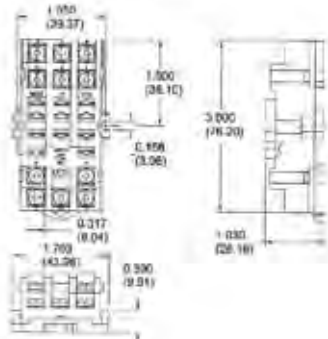
Normal 11 pin product with configuration for Remote Adjust (2-6 Control Switch)

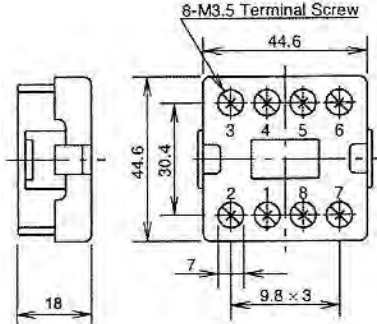
SOCKETS & ACCESSORIES

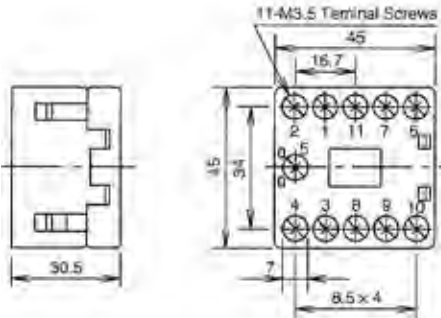
<p>8 Pin Octal Socket-- Surface or DIN Rail-Mounted</p> <p>10A @ 600V * 1 or 2 #12-22 AWG Wire Pressure Wire Clamp Terminations</p> 	<p>Product Number 70169-D</p> 	
<p>11 Pin Octal Socket-- Surface or DIN Rail-Mounted</p> <p>10A @ 300V 1 or 2 #12-22 AWG Wire Pressure Wire Clamp Terminations</p> 	<p>Product Number 70170-D</p> 	
<p>11 Pin Quick-Connect Socket-- Surface or DIN Rail-Mounted</p> <p>10A @ 300V 1 or 2 #12-22 AWG Wire Pressure Wire Clamp Terminations</p> 	<p>Product Number 70171-D</p> 	
<p>8 Pin Octal Socket-- Back-Mounted</p> <p>10A @ 300V Pressure Wire Clamp Terminations</p>	<p>Product Number SR6P-M08G</p> 	
<p>11 Pin Octal Socket-- Back-Mounted</p> <p>10A @ 300V Pressure Wire Clamp Terminations</p>	<p>Product Number SR6P-M11G</p> 	

* Plug-in Three-Phase Monitor Relays require a 600V-rated socket when used on system voltages greater than 300V.

SOCKETS & ACCESSORIES

12 Pin Socket-- Surface or DIN Rail-Mounted

Product Number 27390D

10A @ 600V
#12-20 AWG Wire
Pressure Wire Clamp Terminations

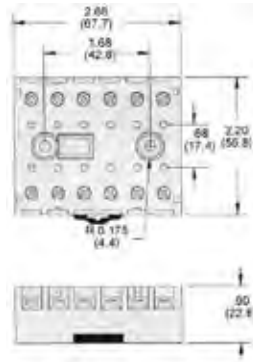

Hold Down Spring Product Number 70166

Can be used for:

- ◆ Panel-Mounted Sockets
- ◆ Sockets Mounted to 35mm DIN Track *

* Requires two machine screws with washers & nuts-- contact Macromatic for more information.



35mm DIN Mounting Track (1 Meter Section) Product Number 70100



Panel Mount Assembly For Panel Mounting Standard Plug-in Products Product Number 70400

This assembly provides a simple & economical method to mount plug-in products to the deadfront of an enclosure/panel:

- ◆ Sturdy aluminum construction
- ◆ Stainless steel studs
- ◆ All mounting hardware included
- ◆ White textured painted finish
- ◆ 2 3/16" W x 3 7/16" H

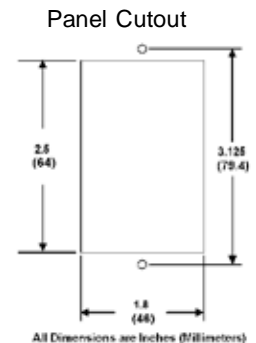
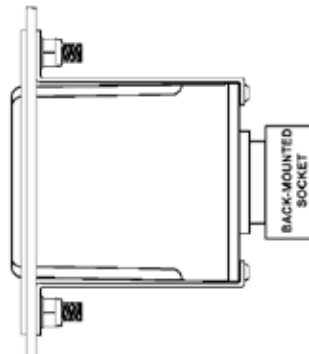

(Relay Not Included with Assembly--
Shown for Reference Only)

More Information

To learn more about the complete line of products from Macromatic, visit our website at www.macromatic.com, where you can:

- Download a complete catalog or individual section on any of our products
- Use our interactive **Product Builder** to identify the exact catalog number of the product you require
- Create and print an e-Product Data Sheet and/or Installation Sheet for any specific catalog number
- Obtain technical support by reviewing answers to the most frequently asked questions
- Search our **Knowledge Base**, an interactive library of technical issues & solutions

Or call us at **800-238-7474** or e-mail us at sales@macromatic.com to request a catalog.



Better. By Design.



W134 N5345 Campbell Drive, Menomonee Falls, WI 53051

800.238.7474 262.781.3366 FAX: 262.781.4433

sales@macromatic.com

www.macromatic.com

At right - photo of Amarex KRT Pump courtesy of KSB Pumps Inc., Canada

901-000-045

0109

Distributed by Gross Automation | +1 (262) 252-1600 | sales@grossautomation.com